

[54] **IMAGE REGISTRATION IN A MULTIPLE MAGNIFICATION PHOTOCOPYING SYSTEM**

[75] Inventors: **Gerald A. Buddendeck; Herman L. Cox**, both of Rochester, N.Y.

[73] Assignee: **Xerox Corporation**, Stamford, Conn.

[22] Filed: **Jan. 8, 1973**

[21] Appl. No.: **321,627**

**Related U.S. Application Data**

[63] Continuation of Ser. No. 152,134, June 11, 1971, abandoned.

[52] U.S. Cl. .... **355/14, 355/57, 355/66**

[51] Int. Cl. .... **G03g 15/00**

[58] Field of Search ..... **355/3, 14, 66, 57; 95/4.5**

[56] **References Cited**

**UNITED STATES PATENTS**

2,160,277 5/1939 Neidich ..... 95/4.5 J

3,437,410	4/1969	Tregay et al. ....	355/66 X
3,549,254	12/1970	Muir .....	355/14 X
3,572,924	3/1971	Matsumoto .....	355/57
3,586,437	6/1971	Dietz et al. ....	355/14
3,669,412	6/1972	Ogawa .....	355/14 X
3,716,294	2/1973	Knechtel et al. ....	355/14 X

*Primary Examiner*—Samuel S. Matthews  
*Assistant Examiner*—Richard A. Wintercorn

[57] **ABSTRACT**

A xerographic machine with multiple magnification capabilities employs a multiple focus lens system designed to operate under fixed overall conjugate conditions. The lens system is supported for displacements along its optical axis to effect various magnifications and for displacements perpendicular to the optical axis to regulate the dimensions of the borders on the copies produced by the machine.

**19 Claims, 6 Drawing Figures**

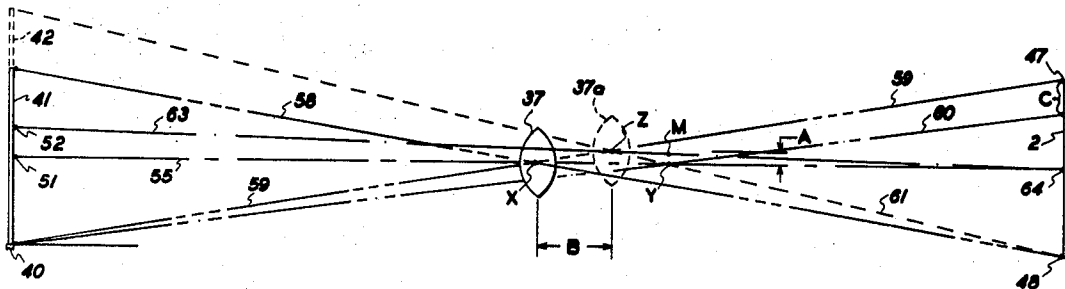

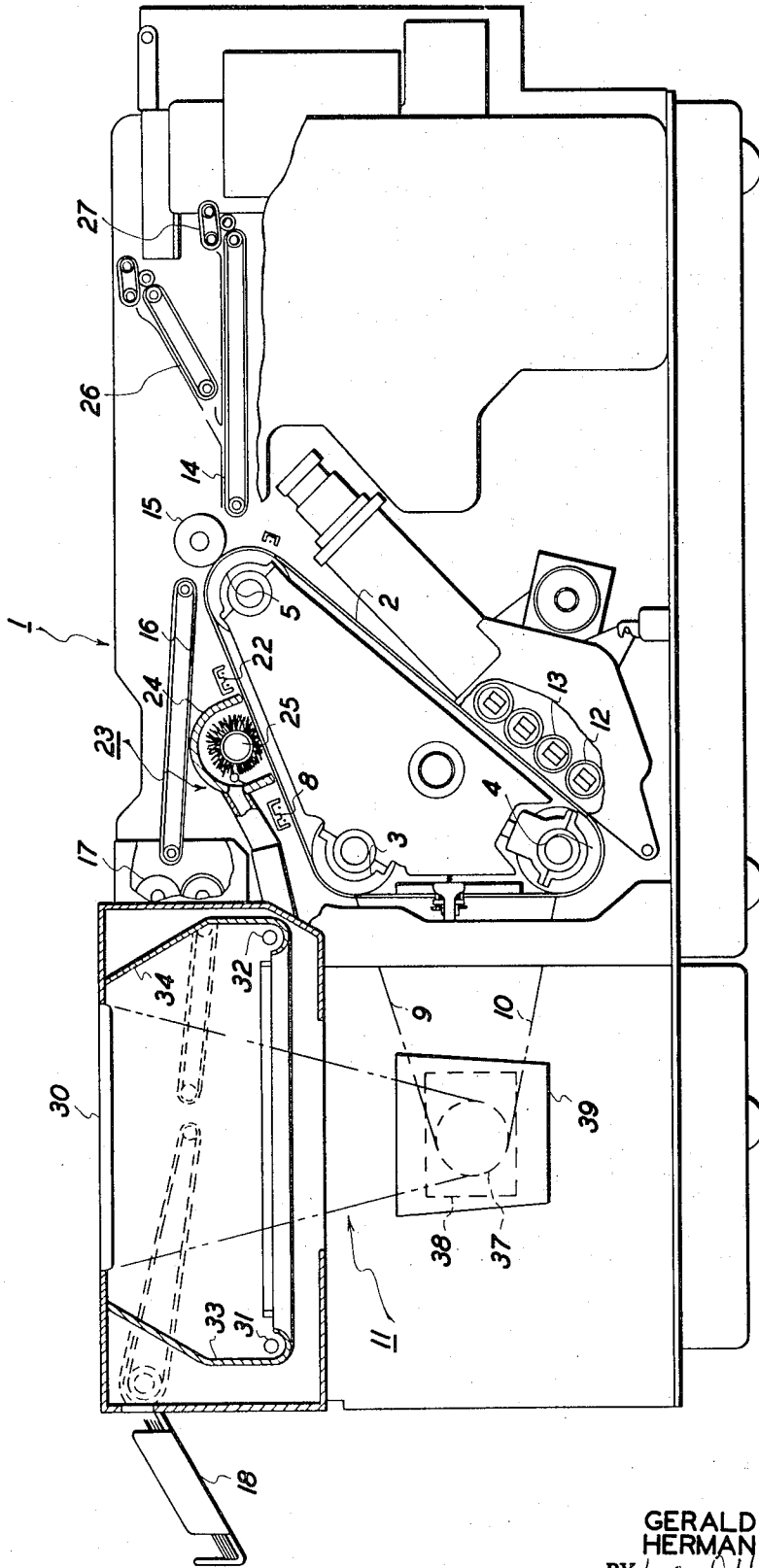

FIG. 1

INVENTORS,  
GERALD A. BUDDENDECK  
HERMAN L. COX  
BY *Michael H. Shumaker*  
ATTORNEY

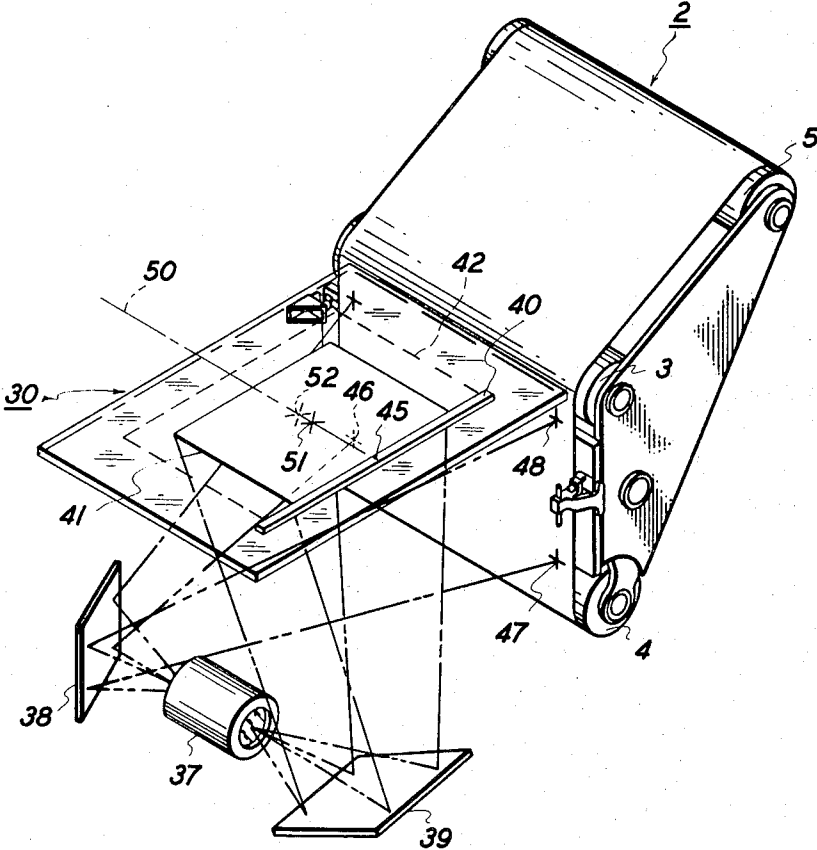

FIG. 2



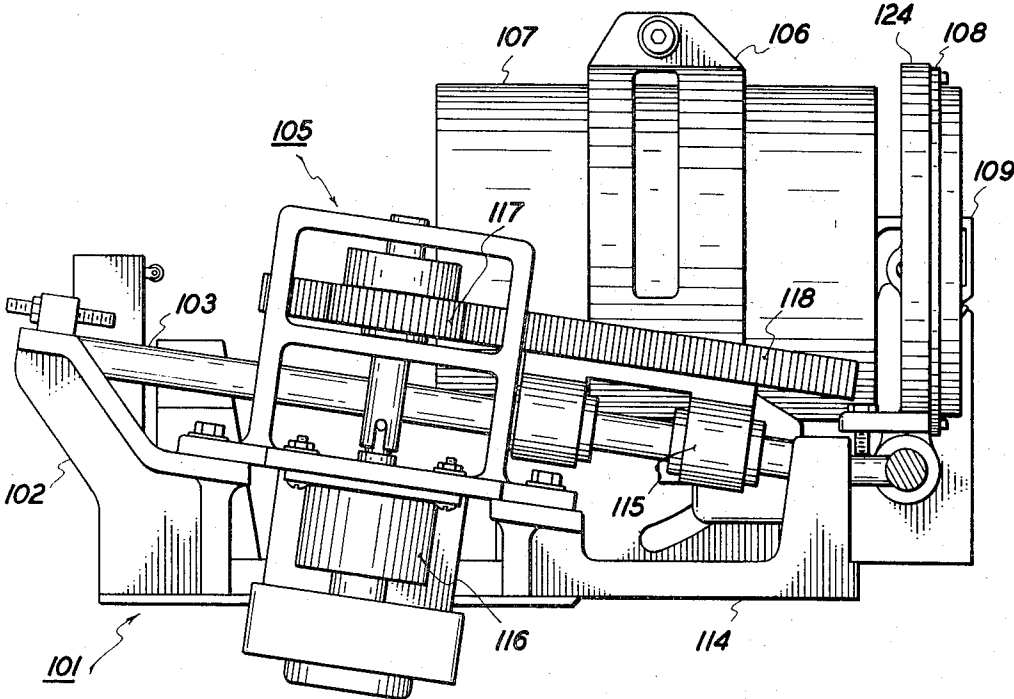

FIG. 4

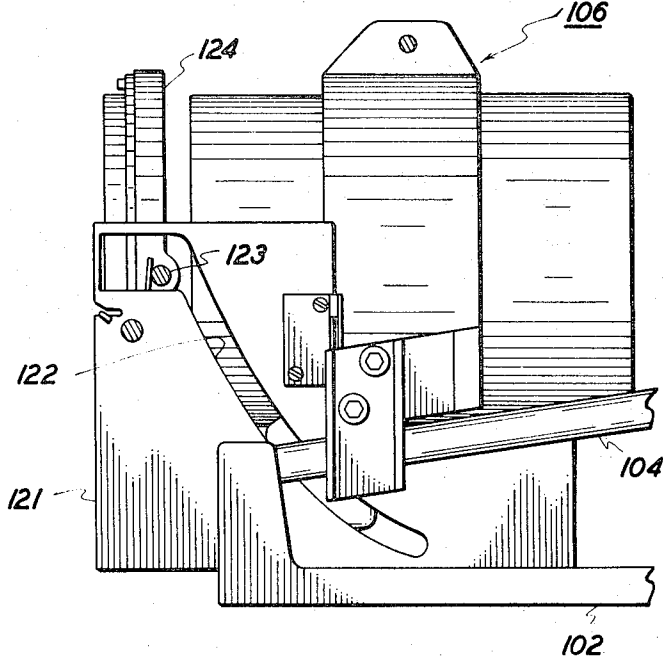

FIG. 6

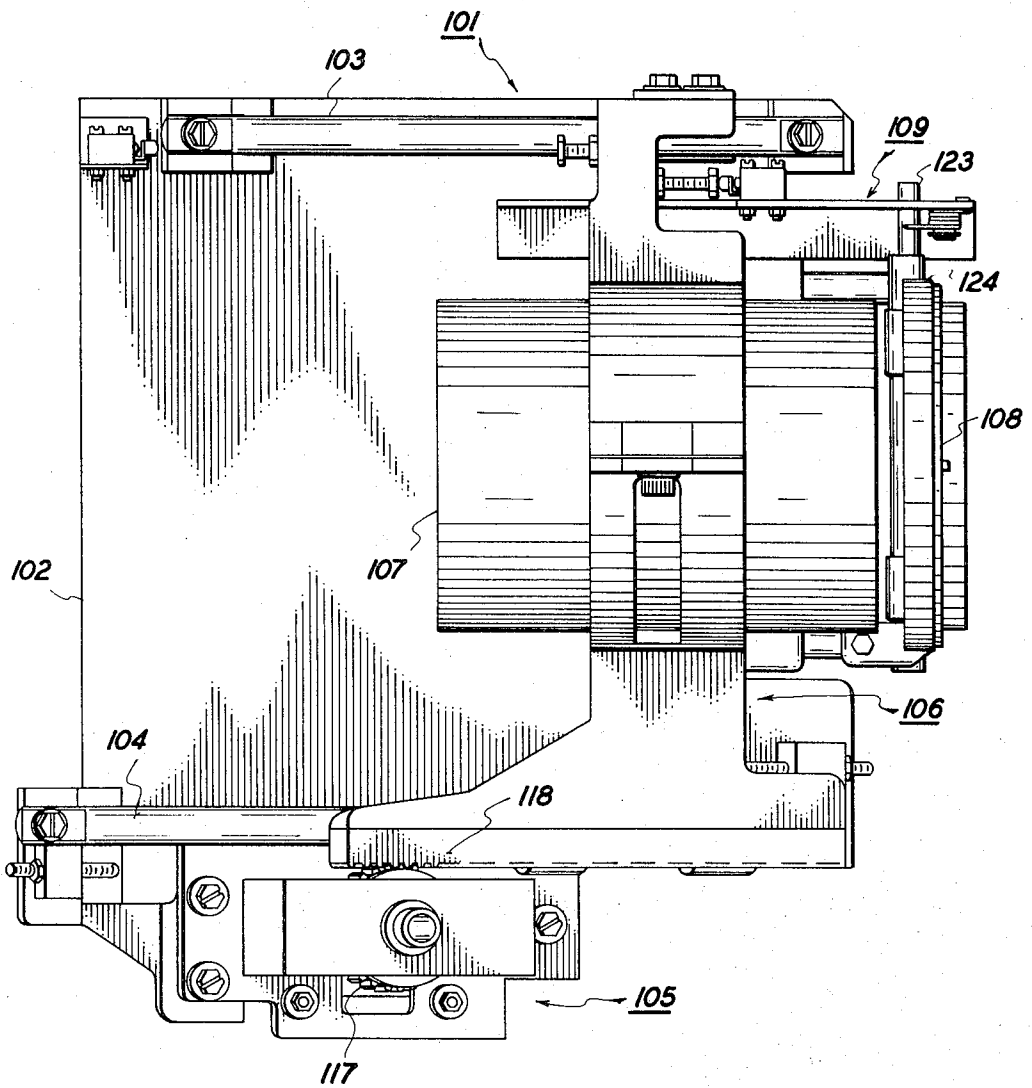

FIG. 5

## IMAGE REGISTRATION IN A MULTIPLE MAGNIFICATION PHOTOCOPYING SYSTEM

This is a continuation, of application Serial No. 152,134 filed 6/11/71 now abandoned.

### BACKGROUND OF THE INVENTION

This invention relates to photocopying systems and in particular to methods and apparatus for regulating the dimensions of the borders on copies made by photocopying systems having variable magnification capabilities.

Typically, photocopying systems generate copies by exposing a photosensitive target to a light image, i.e., electromagnetic radiation in imagewise configuration. The exposure of the photosensitive target gives rise to a latent image in or on the target that is developed, i.e., rendered visible, simultaneously or subsequently to the exposure. The developed image, while on the target, can comprise the final product or the developed image may be transferred to a transfer member such as ordinary paper. The light image can be generated by a plurality of means including a cathode ray tube (CRT), light image generating means other than a CRT, illuminating an opaque original or illuminating a transparent original.

A variable magnification capability can be incorporated into a photocopying system by using add lens or other variable focus lens systems designed for fixed overall conjugate environments to project the light image to the target. Conventionally, the location of the object and image planes of the lens system are fixed with the light image being projected from the object plane to the photosensitive target located at the image plane. Different magnifications are possible by moving the lens system along the optical axis toward the target to reduce the size of the projected light image and by moving the lens system along the optical axis away from the target to increase the size of the projected light image. The add lens and other multiple focus lens systems include provisions for maintaining the projected light image in focus when the lens elements are positioned at different locations relative to the target.

To maintain a light image centered on the target for a plurality of different magnifications of the light image, (assuming for the present that centering is the desired border regulation), the location of the light image and/or the target must be adjusted in two dimensions in the object and image planes of the lens system. For example, the lens system may initially be positioned for a 1:1 projection of a light image movable in the object plane to a target fixed in the image plane. To project a larger size light image to the same target so the larger image is confined to the area on the target occupied by the image in the 1:1 case, the lens system is moved along the optical axis toward the target to effect the necessary image reduction, (automatic focus is assumed). In addition, the larger light image must be positioned over the original image in a concentric fashion with balanced amounts of overlap on all sides, i.e., the larger image must be centered over the smaller by some machine or hand operation. If the centering operation is not followed, portions of the projected light image will fall outside the target area resulting in partial loss of the image or at least creation of non-symmetrical borders around the final copy. This example illustrates

one drawback of photocopying systems designed to reduce large documents to a single convenient size. An analogous drawback is associated with systems designed for image enlargement wherein a light image such as a micro image is blown up to different sizes. The drawback lies with the multiple directional manipulation of the light image and/or the target in order to prevent image loss and/or to regulate the dimensions of the borders in the final copy. The multiple direction manipulations are undesirable because it complicates the photocopying system design.

Accordingly, it is an object of this invention to overcome the above noted drawback and other similar problems encountered by prior art photocopying systems capable of two or more magnifications.

Specifically, it is an object of the present invention for image alignment purposes to limit target and/or light image manipulation in photocopying machines to movements along a single coordinate.

Yet another object of this invention is to enhance the performance of add lens and other multiple focus lens systems by introducing lens element displacements away from an optical axis in addition to lens displacements along the optical axis.

Still another object of the instant invention is to regulate the dimensions of copy borders for photocopying machines of the type wherein the photosensitive target travels through the lens system image plane by displacing the image forming area of the target by electrically delaying or accelerating the start of the image forming process.

Another object of this invention is to devise method and apparatus for regulating borders in a xerographic photocopying machine employing flash or instantaneous exposure of a planar surface of an electrically photosensitive target in web form.

Even another object of this invention is to design an exposure mechanism for a photocopying machine wherein different size documents are projected to a fixed target area in registration by simply aligning one edge of any size document against a linear registration guide.

Another object of this invention is to devise reliable and economic methods and apparatus for the displacement of multiple focus lens systems relative to the optical axis of the lens systems.

These and other objects of the present invention are realized by employing novel photocopying methods and apparatus for projecting various size light images to a single size photosensitive target. One technique includes displacing a projection lens system perpendicular to its optical axis in addition to along the optical axis. Another technique includes delaying or accelerating the instant in time at which image formation takes place. Both techniques permit multiple size light images to be projected and reduced or enlarged to the same target area while requiring the light image (and/or the target) to be moved along one rather than two coordinates.

### DESCRIPTION OF THE DRAWINGS

Other objects and features of the instant invention will be apparent from the present description and from the drawings which are:

FIG. 1 is a side view in partial cut-away of a xerographic photocopying machine having a multiple mag-

nification capability in which the present invention is employed.

FIG. 2 is a perspective view of the exposure mechanism used in the machine in FIG. 1.

FIG. 3 is a simplified schematic of the optical path of the apparatus in FIG. 2 unfolded into a generally linear path by eliminating the plane mirrors in FIG. 2.

FIG. 4 is a side elevation view of apparatus for effecting displacement of an add lens system along and away from the initial optical axis.

FIG. 5 is a plan view of the apparatus of FIG. 4.

FIG. 6 is a partial elevation view of the apparatus of FIG. 4, as viewed from the side opposite to that in FIG. 4, illustrating the cam for inserting an add lens into the lens system.

### DESCRIPTION OF THE EMBODIMENTS

The following description of this invention is in terms of a xerographic photocopying machine that provides 1:1 magnification and image reduction. It is to be understood that the methods and apparatus disclosed may be readily adapted to a machine having an image enlargement capability and to photocopying machines utilizing electrical, magnetic, chemical, heat and/or other image forming processes.

The xerographic photocopying machine 1 of FIG. 1, includes the electrically photosensitive target 2 that is in the form of a continuous web or belt. The belt 2 is appropriately supported for travel in a rotary fashion around the rollers 3, 4 and 5. The outside surface of the belt has electrostatic charge continuously deposited onto it as it passes the charging corotron 8. The charged belt is exposed to a light image between rollers 3 and 4 as indicated roughly by the light rays 9 and 10 projected by the exposure mechanism 11. The light alters the electrostatic charge on the photosensitive belt giving rise to a latent electrostatic image.

The latent electrostatic image is developed as the belt travels past the developing apparatus 12 which includes a plurality of magnetic brush developer rollers 13. The developing apparatus presents electrically charged marking or toner particles adjacent the latent image which are electrically attracted to the belt in imagewise configuration yielding a developed or visible toner image. The toner image is transferred from the belt to a transfer member (e.g., ordinary paper) fed to the belt in registration with the toner image.

A transfer member is transported to the belt 2 by an appropriate means including the transport mechanism 14. The transfer of the toner image takes place when the transfer member and belt pass the electrically biased transfer roller 15. The toner image on the transfer member is carried by the conveyor 16 to a suitable fusing mechanism 17 where the toner image is permanently fixed to the transfer member. The fixed toner image is the final product or copy which is collected in the output tray 18.

The belt area on which the foregoing toner image is formed is reconditioned for formation of another image by the preclean charging corotron 22 and the cleaning device 23. Device 23 includes a rotary brush 25 surrounded by a housing 24 which is connected to a vacuum source. The belt thereafter returns to its starting position underneath the charging corotron 8 which prepares the belt for formation of a new toner image.

Machine 1 is capable of forming copies on different size transfer members which are supplied to the belt

over two different transport paths partially defined by transport mechanisms 26 and 27.

The specific charging, developing, transferring, fusing and transporting mechanisms disclosed in the drawings and described herein are explained in greater detail in copending applications entitled "Controlling Multiple Voltage Levels for Electrostatic Printing" in the name of Feldeisen et al., Ser. No. 152,138, and "Corotron Structure for Electrostatic Machines" in the name of Daniel L. Mueller, Ser. No. 152,137 both filed currently herewith and the U.S. Pat. No. 3,661,452 in the name of Hewes et al. The disclosures of these copending applications are incorporated herein by reference. For other descriptions of xerographic process steps see U.S. Pat. Nos. 3,062,109 and 3,301,126 and the patents mentioned therein which are also incorporated herein by reference.

The projection or exposure mechanism 11 with which the present invention is primarily concerned is comprised of the platen 30 which holds the opaque originals or documents that are copied. The platen is uniformly flooded with electromagnetic radiation generated by the lamps 31 and 32 and directed to the platen by the mirror reflectors 33 and 34. The light reflected off a document on the platen comprises the light image to which the belt 2 is exposed. This light image is projected to the belt by the lens system 37 and plane mirrors 38 and 39.

The duration of the exposure, i.e., the length of time the lamps 31 and 32 generate radiation, is such that the belt 2 can be assumed stationary during the exposure period. Consequently, the location of an image on the belt is controlled by accelerating or delaying the instant at which the lamps are turned on, i.e., flashed. The acceleration or delay of the flash exposure is conveniently provided by electrical circuitry known to those skilled in the art since the lamps are electrically operated illumination sources. The moment of flash is determined by timing means operated in conjunction with the cyclic travel of the belt around rollers 3, 4, and 5.

FIG. 2, depicts the exposure mechanism of the presently discussed embodiment which includes the platen 30, linear registration guide 40, the different size documents 41 and 42, plane mirrors 38 and 39, the lens system 37 and the plane surface of belt 2 between rollers 3 and 4. The registration guide includes a calibrated straight edge having means such as a mark 45 for registering one dimension of a document to the belt 2. The alignment of a document to the registration guide establishes the location of the latent electrostatic image on belt 2 between the lateral boundaries of the belt conveniently represented by the imaginary registration marks 46 and 47. The location of the latent image between the imaginary registration marks 47 and 48 is established by alignment of the optical axis of the lens system 37 relative to a document and the target.

As mentioned earlier, the belt surface area on which the latent electrostatic image is formed can be varied by accelerating or delaying the flash of the exposure lamps. This variation to the flash ultimately shifts the toner image on the transfer member because the belt speed and the instant in time at which the belt intercepts the transfer member are fixed.

The coordinate defined by a line between imaginary marks 47 and 48 is parallel to the coordinate 50 if the effect of mirrors 38 and 39 is ignored. Coordinate 50 is the dimension of the latent image in which a registra-

tion change will occur when different size documents are aligned to the registration guide 40. The cross marks 51 and 52 represent the geometric center of two arbitrarily selected documents 41 and 42, respectively. These geometric centers lie on line 50 because one edge of each document is centered (assuming for the present that centering defines the desired border condition) to mark 45 on the registration guide. This means that when the lens system 37 is displaced along the optical axis to change the magnification, the location of the projected image relative to the imaginary marks 47 and 48 changes. The shift in latent image location causes a copy of document 41 to have different border dimensions than a copy of document 42. One goal of this invention is to make the borders on both copies substantially the same or at least symmetrical.

FIG. 3 is helpful in understanding the above registration problem and the present solution of the problem. The drawing is a simplified schematic of a ray trace for the lens system of FIG. 2, with the mirrors 38 and 39 removed. The schematic illustrates edges of documents 41 and 42 that are parallel to line 50 in FIG. 2 and the edge of belt 2 parallel to a line between imaginary marks 47 and 48. The lens system 37 is shown as a single lens element with the solid lines 37 representing the lens position for a 1:1 projection of document 41 to a position between imaginary marks 47 and 48 and the dashed lines 37a representing the lens system position for projecting the larger document 42 to the same location between marks 47 and 48.

Prior art add lens systems called for the positioning of the lens system 37 at locations broadly defined by points X and Y for projection of different size documents such as documents 41 and 42. Point X is the location for a 1:1 magnification and point Y is the location for an image reduction. The image of document 41 projected with the lens at point X completely fills the area between marks 47 and 48 as indicated by rays 58 and 59 which is assumed for present purposes to be a condition yielding copies with no borders. The image of document 42 projected with the lens at point Y fills less than all the area between marks 47 and 48 as indicated by the rays 60 and 61. This means the copy made of document 41 has no border and the copy of document 42 has a single or non-symmetrical border along the edge that was adjacent mark 47.

The present inventors overcame the foregoing problem by discovering that the image of document 42 can be made to fill the entire area between marks 47 and 48 as indicated by rays 59 and 61 by positioning the lens at point Z. The usefulness of point Z is not readily apparent because add lens and other multiple focus lens systems heretofore have always described lens element displacements as being along a fixed optical axis. Point Z, of course, is displaced perpendicularly from the optical axis 55 by the amount A which is contrary to prior systems. The new optical axis is parallel to axis 55.

It is within the scope of this invention to move the lens element to point M displaced upward from point Y by an amount  $\frac{1}{2}C$  where C is the border width produced by positioning the lens at point Y. With the lens at point M the border on the copy of document 42 is not identical to that on the copy of document 41 but at least the copy has symmetrical borders, i.e. borders of  $\frac{1}{2}C$  at each end.

The unique point Z at which copies of different size documents have substantially the same borders at ends adjacent marks 47 and 48 is defined by the intersection of the extreme rays drawn between opposite ends of a document and the target, e.g. rays 59 and 61. (In this regard, the distance between imaginary registration points 47 and 48 can vary if different magnifications are desired. Fixed registration marks are illustrated and discussed to help explain the principals of the present invention but the invention is not intended to be limited to that condition.)

An infinite number of points M at which symmetrical borders are yielded for copies of document 42 lie along line 63 drawn between the center 52 of the document and the center 64 of the target. The lens is moved along optical axis 55 to obtain the desired magnification and then displaced upward to line 63 to achieve the symmetrical border condition. (Note that point Z is a special case of a point M.)

FIGS. 4, 5 and 6 illustrate a displacement mechanism 101 for effecting the on-axis and off-axis displacements of an add lens system. Mechanism 101 includes a frame 102, inclined rails 103 and 104, drive unit 105, carriage 106 that carries the main lens element 107 and an add lens element 108 and a cam unit 109. The lens elements 107 (that is the elements housed inside the barrel) and the add lens elements comprise an add lens system designated by reference number 37 in FIGS. 1, 2 and 3. For a full description of add lens systems see U.S. Pat. No. 3,476,478. The disclosure of that patent is incorporated herein by reference. The frame 102 is supported in machine 1 between mirrors 38 and 39 with bottom surface 114 parallel to an optical axis such as axis 55 in FIG. 3. The linear rails 103 and 104 are sloped or inclined relative to surface 114 to position the lens elements 107 and 108 (as needed) between points corresponding to points X and Z (or M) illustrated in FIG. 3.

The rails 103 and 104 are appropriately supported by the frame 102. The carriage 106 is slidably mounted on the rails at four places by suitable bearings 115. The carriage is propelled back and forth along the rails by the drive unit 105. The drive unit includes a suitable electric motor 116 supported by the frame and having the pinion gear 117 coupled to its drive shaft. The pinion gear is mated with the rack gear 118 rigidly coupled to the carriage 106. The pinion and rack gears are oriented in the plane of the rails as best seen in FIG. 4. The motor is reversible and the pinion gear is rotated clockwise and counterclockwise to propel the carriage back and forth along the rails. Appropriate contact switches secured to the frame are tripped by the carriage to stop the motor when a desired rail position is reached.

The cam unit 109 includes the cam plate 121 rigidly coupled to the frame having the arc or cam surface 122 cut therein. The cam follower 123 is rigidly coupled to brace 124 which in turn is pivotally journaled to the carriage 106. The add lens 108 is supported in the brace. Consequently, the add lens is positioned as shown in FIGS. 4, 5 and 6 when the carriage is near the end of the rails closest to the bottom frame surface 114. This position of the brace centers the add lens 108 about the optical axis of the main lens 107. When the carriage travels toward the opposite ends of the rails, the cam follower forces the brace downward as it travels the cam surface. At some point along the rails the

add lens 108 is removed from the optical path of the main lens 107.

The length of the rails may be extended to permit more add lens elements to be used. Also, an add lens is not necessary to every position along the rails. Accordingly, the photocopying machine can position the lens system at several different positions along the rails to achieve equal numbers of different magnifications. The Z points or M points for a system using more than two magnifications may not fall in a straight line. A non-linear rail path can be provided in this case. Alternately, errors in the location of Z and M points caused by the linear rails can be offset by using the earlier described technique of delaying or accelerating the flash exposure to shift the location of latent image an appropriate amount on the belt 2.

As mentioned at the outset, this invention is not intended to be limited to the specific embodiments shown but to include those inventions logically suggested by the present disclosure.

What is claimed is:

1. Exposure apparatus for regulating borders on copies produced by a photocopying machine capable of generating a light image for exposing a photosensitive target comprising

a single multiple focus lens system for fixed overall conjugate projections positioned relative to said light image and target such that the light image is in the object plane of the lens system and the target is in the image plane of the lens system,

a photosensitive target including a photosensitive member in web form with a plane surface thereof supported for movement through the image plane of said lens system,

means for generating said light image including flash lamp means positioned to illuminate a platen for supporting an opaque document wherein said lamp illuminates said platen for a period of time sufficiently short to permit the target to be considered substantially stationary during exposure,

electrical means for controlling the instant in time at which said flash lamp illuminates the platen for regulating the dimensions of borders associated with the copies produced by the machine, and

displacement means for supporting said lens system and for displacing the lens system parallel to the optical axis to obtain different size focused projections of said light images on the target and for displacing the lens system perpendicular to the optical axis to regulate the dimensions of borders associated with copies produced by the machine.

2. The apparatus of claim 1 further including registration means positioned in said image plane for aligning one edge of said light image relative to said target.

3. The apparatus of claim 1 wherein said lens system includes an add lens system comprising main lens elements and at least one add lens element.

4. The apparatus of claim 3 further including at least one plane mirror for folding the optical path of the lens system without changing the overall conjugate.

5. The apparatus of claim 4 including two plane mirrors for folding the optical path of said lens system without changing the overall conjugate.

6. The apparatus of claim 1 wherein said photosensitive target includes an electrically photosensitive mem-

ber on which a latent electrostatic image is formed upon exposure of the target to the light image.

7. The apparatus of claim 6 wherein said photocopying machine is a xerographic machine including means for developing said latent electrostatic image forming a toner image, means for transferring said toner image to a transfer member and means for fixing said toner image permanently to the transfer member.

8. The apparatus of claim 7 wherein said photosensitive target includes reusable surface areas and said xerographic machine further includes means for cleaning said target after the toner image is transferred therefrom.

9. The apparatus of claim 1 wherein said displacement means includes means for positioning said lens system to at least points X and Z where X is a first lens system position for projecting a focused image of a first light image to the target and Z is a second lens system position for projecting a focused image of a larger light image to the target where Z is defined by the intersection of extreme rays projected from the larger light image to the boundaries of the target.

10. The apparatus of claim 1 wherein said displacement means includes means for positioning said lens system to at least points X and M where X is a first lens system position for projecting a focused image of a first light image to the target and M is a second lens system position for projecting a focused image of a larger light image to the target where M is defined by the intersection of a line drawn from the center of the larger light image to the center of the target and a line normal to the optical axis.

11. The apparatus of claim 9 wherein said displacement means includes means coupled to said lens system and slidably coupled to at least one linear rail oriented substantially parallel to a line drawn between points X and Z.

12. The apparatus of claim 10 wherein said displacement means includes means coupled to said lens system and slidably coupled to at least one linear rail oriented substantially parallel to a line drawn between points X and M.

13. The apparatus of claim 12 wherein said displacement means includes means to position said lens system at point X and a plurality of point M's with said rail oriented parallel to the line drawn between point X and the M point furthest from the X point.

14. Exposure apparatus for regulating borders on copies produced by a photocopying machine comprising

a photosensitive target including a plane surface image forming area capable of having a latent electrostatic image created thereon upon exposure to a light image,

means for generating in a fixedly located plane light images of more than one size with one edge of all sizes of light images being aligned relative to one edge of the image forming area of the target for regulating the borders on two opposite sides of said copies,

a multiple focus lens system including means for changing focal length to project light images of different size to the target without any projected image substantially exceeding the dimensions of the image forming area upon moving the lens system parallel to the optical axis but without changing the length of the overall conjugate and

displacement means for moving said lens system along a linear path angled to the optical axis defined by points X and M where X is a lens system position for projecting a light image of first size to the target with the optical axis coincident with a line between the centers of the light image and target and where M is the intersection of a line between the centers of the target and a light image of second size and a normal from point Y on the X position optical axis where Y is the lens system position for projecting a light image of a second size to the target

said M lens system position causing the production of copies having borders differing from those resulting from the X lens system position but which are nonetheless symmetrical on opposite sides of the copies.

15. Exposure apparatus for regulating borders on copies produced by a photocopying machine comprising

a photosensitive target including a plane surface image forming area capable of having a latent electrostatic image formed thereon upon exposure to a light image,

means for generating in a fixedly located plane light images of at least three sizes being equal to or greater than the image forming area of the target with one edge of all sizes of light images being aligned relative to one edge of the image forming area on the target for regulating the borders on opposite sides of said copies,

a multiple focus lens system including means for changing the focal length for the projection of at least said three light images to the target without any projected image substantially exceeding the dimensions of the image forming area upon moving the lens system along the optical axis but without changing the length of the overall conjugate and displacement means for moving said lens system to at least three positions along a linear path at an angle to the optical axis defined by points X and M where X is a lens system position for projecting a light image of first size to the target with the optical axis coincident with a line between the centers of the light image and target and where M is the intersection of a line between the centers of the target and a light image of a second larger size and a normal from point Y on the X position optical axis where Y is the lens system position for projecting said light image of second size to the target,

said third lens system position on said linear path not including the point of intersection between the line between the centers of the target and a light image of third size and a normal from point Y on the X position optical axis where Y is the lens system position for projecting said light image of said third

size to the target.

16. The apparatus of claim 15 wherein said target is supported for movement through the image plane of said lens system, said means for generating light images includes flash lamp means for illuminating a platen for supporting opaque documents, said period of illumination being a time sufficiently short compared to the rate of travel of the target to enable the target to be considered stationary during the exposure and further including electrical circuit means for controlling the instant in time the illumination occurs in order to regulate the borders associated with copies produced when said lens system is positioned at said third lens system position.

17. An electrostatic reproduction machine having an illumination means wherein copies of an original document are produced by flashing the illumination means to produce a flashed light image onto a photoreceptor and effect an electrostatic latent image thereon disposed in an image plane, including,

lens means for projecting a flashed light image of said original document onto said photoreceptor, means for producing a flash exposure of the document in timed relation with the movement of the photoreceptor, and

flash control means coupled to said producing means for effecting flash energizing of the illumination means to generate a flashed light image, said flash control means being responsive to a selectable means for varying the application of said flash energization of said illumination means for a predetermined time duration thereby shifting the formation of an electrostatic latent image on the photoreceptor relative to its machine-timed position without the varying of flash exposure.

18. The machine of claim 17 wherein said varying of the application of flash energization is such as to delay flash exposure.

19. An electrostatic reproduction machine having an illumination means for producing electrostatic latent images upon a moving photoreceptor web thereon; developing apparatus for developing the latent images; sheet feed means for feeding sheets serially to the developed images; transfer means for effecting the transfer of developed images to sheets; and machine control means for (a) flashing the illumination means, (b) for activating the sheet feed means and (c) the transfer means in timed relation to the moving photoreceptor web, the improvement including

flash control means coupled to the machine control means being responsive to a selectable means for delaying the application of the flashing of the illumination means while maintaining the timed relationship for the activation of the sheet feed means.

\* \* \* \* \*