



(51) International Patent Classification:

A61M 25/00 (2006.01) A61B 90/00 (2016.01)
A61M 25/01 (2006.01)

(21) International Application Number:

PCT/US2015/036363

(22) International Filing Date:

18 June 2015 (18.06.2015)

(25) Filing Language:

English

(26) Publication Language:

English

(71) Applicant: AVENT, INC. [US/US]; 5405 Windward Parkway, Alpharetta, Georgia 30004 (US).

(72) Inventors: KHALAJ, Steve; 5405 Windward Parkway, Alpharetta, Georgia 30004 (US). ROTELLA, John, Anthony; 5405 Windward Parkway, Alpharetta, Georgia 30004 (US). COKER, Justin Jeffrey; 5405 Windward Parkway, Alpharetta, Georgia 30004 (US).

(74) Agents: STOKES, Maegen W. et al.; Dority & Manning, P.A., P.O. Box 1449, Greenville, South Carolina 29602-1449 (US).

(81) Designated States (unless otherwise indicated, for every kind of national protection available):

AE, AG, AL, AM, AO, AT, AU, AZ, BA, BB, BG, BH, BN, BR, BW, BY, BZ, CA, CH, CL, CN, CO, CR, CU, CZ, DE, DK, DM, DO, DZ, EC, EE, EG, ES, FI, GB, GD, GE, GH, GM, GT, HN, HR, HU, ID, IL, IN, IR, IS, JP, KE, KG, KN, KP, KR, KZ, LA, LC, LK, LR, LS, LU, LY, MA, MD, ME, MG, MK, MN, MW, MX, MY, MZ, NA, NG, NI, NO, NZ, OM, PA, PE, PG, PH, PL, PT, QA, RO, RS, RU, RW, SA, SC, SD, SE, SG, SK, SL, SM, ST, SV, SY, TH, TJ, TM, TN, TR, TT, TZ, UA, UG, US, UZ, VC, VN, ZA, ZM, ZW.

(84) Designated States (unless otherwise indicated, for every kind of regional protection available):

ARIPO (BW, GH, GM, KE, LR, LS, MW, MZ, NA, RW, SD, SL, ST, SZ, TZ, UG, ZM, ZW), Eurasian (AM, AZ, BY, KG, KZ, RU, TJ, TM), European (AL, AT, BE, BG, CH, CY, CZ, DE, DK, EE, ES, FI, FR, GB, GR, HR, HU, IE, IS, IT, LT, LU, LV, MC, MK, MT, NL, NO, PL, PT, RO, RS, SE, SI, SK, SM, TR), OAPI (BF, BJ, CF, CG, CI, CM, GA, GN, GQ, GW, KM, ML, MR, NE, SN, TD, TG).

Published:

— with international search report (Art. 21(3))

(54) Title: ECHOGENIC COIL MEMBER FOR A CATHETER ASSEMBLY

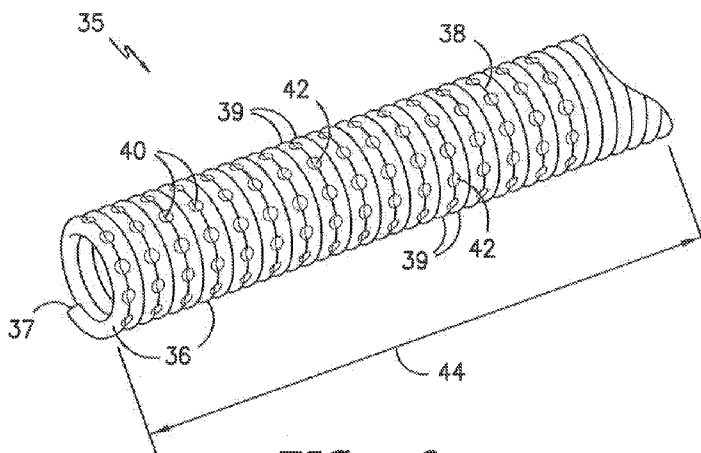

FIG. -6-

(57) Abstract: The present invention is directed to an echogenic coil member for a catheter assembly and methods of manufacturing same. The catheter assembly includes a catheter having a proximal end and a distal end that defines a lumen extending from the proximal end to the distal end. Thus, the echogenic coil member is configured within the lumen of the catheter. Further, the coil member includes a plurality of outwardly extending projections that contain a plurality of discontinuities. As such, the discontinuities are configured to enhance ultrasonic imaging of the catheter assembly.



ECHOGENIC COIL MEMBER FOR A CATHETER ASSEMBLY**FIELD OF THE INVENTION**

The present invention relates generally to echogenic devices and more particularly to an
5 echogenic coil member for a catheter assembly that can be inserted into a medium such as biological
tissue and imageable with sonic imaging equipment.

BACKGROUND

Ultrasonic imaging in the medical field is widely used for a variety of applications. In addition
10 to imaging physiological structures and tissue such as organs, tumors, vessels, and the like, it is often
desirable for a physician or technician to have an image of a medical device which has been inserted
into the tissue or passageway of a patient. The types of devices which are surgically sterilized and
inserted into patients are many. Typical examples include: needles, catheters and a variety of other
15 medical products such as stents, dilators, pacing leads, introducers, angiography devices, angioplasty
devices, pacemakers, in-patient appliances such as pumps and other devices. Various approaches
have been used to enhance ultrasonic imaging by modifying the reflective surface characteristics of
these devices.

U.S. Pat. No. 5,081,997 to Bosley, Jr. et al, for "Echogenic Devices, Material and Method"
discloses a device such as a needle that includes an interface having a shape that is formed with a
20 dimension that is less than a wavelength of the incident sonic beam. According to Bosley, Jr. et al.,
the shape includes a dimension such as a radius of curvature which is much less than the wavelength
of the sonic beam. The interface may include the outside surface a device or article or material. That
surface has a plurality of partially spherical discontinuities for producing a scattered component of the
image in response to the incident beam. This image is produced regardless of the incident beam
25 angle of which conventional devices depend for producing a reflected or constructive interference
image. The scattered component of the image is produced when the radius of the partially spherical
discontinuities or a dimension of another geometric shape or surface are much less than the
wavelength of the incoming sonic beam.

U.S. Patent Application Publication No. 2004/0249288 A1 to Ichikawa for "Ultrasonic Puncture
30 Needle" discloses a device including an array of doughnut shaped recesses having a center portion
remaining as a protrusion. According to U.S. Publication No. 2004/0249288 A1, the recesses are also
formed with faces, bottoms and sides being generally flat so to obtain reflection echoes with a great
intensity for the incident ultrasonic waves with a shallow incident angle.

While the approaches described in U.S. Pat. No. 5,081,997 and U.S. Publication No. 2004/0249288 A1 have shown promise, improvements have been sought that would result in an echogenic catheter that provides enhanced ultrasonic imaging, in a manner that is inexpensive to manufacture, and simple and reliable to use.

5 Accordingly, the present disclosure is directed to an echogenic coil member for a catheter assembly that provides enhanced ultrasonic imaging.

SUMMARY OF THE INVENTION

10 Objects and advantages of the invention will be set forth in part in the following description, or may be obvious from the description, or may be learned through practice of the invention.

In one aspect, the present invention is directed to an echogenic catheter assembly. The catheter assembly includes a catheter having a proximal end and a distal end that defines a lumen extending from the proximal end to the distal end. Further, the catheter assembly includes a coil member configured within the lumen of the catheter. The coil member includes a plurality of outwardly
15 extending projections that contain a plurality of discontinuities. As such, the discontinuities are configured to enhance ultrasonic imaging of the catheter assembly.

In one embodiment, the plurality of discontinuities may be located at a distal region of coil member, e.g. at a distal tip of the coil member.

20 In certain embodiments, at least a portion of the coil member may be in a compressed position such that adjacent outwardly extending projections of the compressed portion contact each other. Thus, in such embodiments, one or more discontinuities of contacting adjacent outwardly extending projections may connect to form a larger discontinuity.

In alternative embodiments, at least a portion of the coil member may be in an expanded position such that adjacent outwardly extending projections of the expanded portion are spaced apart
25 from each other. As such, one or more discontinuities of spaced-apart outwardly extending projections are also spaced apart from each other.

In further embodiments, the coil member may be sized to fit within the lumen of the catheter, e.g. such that the coil member can be easily inserted therethrough. In alternative embodiments, the coil member may be embedded into an interior wall of the catheter.

30 In particular embodiments, the discontinuities may include any one of or combination of the following: indentations, grooves, notches, recesses, threads, protrusions, or similar. More specifically, in certain embodiments, the discontinuities may be laser-etched into the coil member. In additional embodiments, the coil member may be constructed of any suitable material, e.g. a metal or metal alloy. For example, in certain embodiments, the metal or metal alloy may include at least one of or a

combination of the following: aluminum, titanium, copper, tin, nickel, zinc, magnesium, stainless steel, or similar.

5 In still further embodiments, the catheter may include a closed distal tip and one or more infusion holes. Thus, the infusion holes are configured to allow a medication flowing through the lumen of the catheter to exit therethrough.

10 In alternative embodiments, the catheter assembly may further include a needle configured within a lumen of the coil member. For example, in certain embodiments, the catheter assembly may be an over-the-needle (OTN) catheter assembly. In such an embodiment, the distal end of the catheter may include an open distal tip. Thus, the needle may be configured to extend past the open distal tip.

15 In another aspect, the present disclosure is directed to a method for manufacturing an echogenic catheter assembly. More specifically, the method includes providing a catheter having a lumen that extends from a proximal end to a distal end thereof. Another step includes etching a plurality of discontinuities onto a wire member. The method also includes coiling the wire member so as to form a coil member having a plurality of outwardly extending projections, wherein the plurality of discontinuities are exposed on an outer surface of the plurality of outwardly extending projections so as to enhance ultrasonic imaging of the catheter assembly. The method also includes inserting the coil member into the lumen of the catheter.

20 In yet another aspect, the present disclosure is directed to a method for manufacturing an echogenic catheter assembly. More specifically, the method includes providing a catheter having a lumen that extends from a proximal end to a distal end thereof. Another step includes coiling a wire member so as to form a coil member having a plurality of outwardly extending projections. The method also includes forming a plurality of discontinuities onto an outer surface of the outwardly extending projections so as to enhance ultrasonic imaging of the catheter assembly. A further step includes inserting the coil member into the lumen of the catheter.

25 In one embodiment, the method may also include forming the plurality of discontinuities onto a distal region of the outer surface of the outwardly extending projections. In another embodiment, the method may also include compressing at least a portion of the coil member such that adjacent outwardly extending projections of the compressed portion contact each other. Thus, in such an embodiment, the method may also include forming one or more discontinuities onto the outer surface of contacting adjacent outwardly extending projections to form one or more larger discontinuities.

30 In alternative embodiments, the method may include expanding at least a portion of the coil member such that adjacent outwardly extending projections of the expanded portion are spaced apart

from each other. Thus, in such an embodiment, the method may also include forming one or more discontinuities onto the outer surface of the spaced-apart adjacent outwardly extending projections.

Further, in certain embodiments, the method may include laser-etching the plurality of discontinuities onto the outer surface of the outwardly extending projections. It should also be

5 understood that the coil member and associated discontinuities may be configured according to the any of the embodiments as described herein.

These and other features, aspects and advantages of the present invention will become better understood with reference to the following description and appended claims. The accompanying drawings, which are incorporated in and constitute a part of this specification, illustrate embodiments of
10 the invention and, together with the description, serve to explain the principles of the invention.

BRIEF DESCRIPTION OF THE DRAWINGS

A full and enabling disclosure of the present invention, including the best mode thereof, directed to one of ordinary skill in the art, is set forth in the specification, which makes reference to the
15 appended figures, in which:

FIG. 1 illustrates a perspective view of one embodiment of an echogenic catheter assembly according to the present disclosure;

FIG. 2 illustrates a perspective view of another embodiment of an echogenic catheter assembly according to the present disclosure;

20 FIG. 3 illustrates a side view of one embodiment of a wire member of a catheter assembly according to the present disclosure;

FIG. 4 illustrates a side view of one embodiment of a wire member configured within a lumen of a catheter of a catheter assembly according to the present disclosure, particularly illustrating a distal region of the wire member having a plurality of discontinuities;

25 FIG. 5 illustrates a side view one embodiment of an echogenic catheter assembly according to the present disclosure, particularly illustrating a coil member configured within a lumen of a catheter of the catheter assembly;

FIG. 6 illustrates a detailed, perspective view one embodiment of a compressed portion of a coil member of a catheter assembly according to the present disclosure, particularly illustrating a distal
30 region of the coil member having a plurality of discontinuities;

FIG. 7 illustrates a side view the coil member of FIG. 6;

FIG. 8 illustrates a detailed, perspective view one embodiment of an expanded portion of a coil member of a catheter assembly according to the present disclosure, particularly illustrating a distal region of the coil member having a plurality of discontinuities;

FIG. 9 illustrates a side view the coil member of FIG. 8; and

FIG. 10 illustrates a flow diagram of one embodiment of manufacturing an echogenic catheter assembly according to the present disclosure.

5

DETAILED DESCRIPTION OF THE INVENTION

Reference will now be made in detail to one or more embodiments of the invention, examples of the invention, examples of which are illustrated in the drawings. Each example and embodiment is provided by way of explanation of the invention, and is not meant as a limitation of the invention. For example, features illustrated or described as part of one embodiment may be used with another
10 embodiment to yield still a further embodiment. It is intended that the invention include these and other modifications and variations as coming within the scope and spirit of the invention.

The positional terms “proximal” and “distal” are used herein to orient the various components relative to each other and to the patient. “Distal” refers to the direction that is closest to the wound site (e.g., the distal end of the connector is the end oriented towards a catheter insertion site), and
15 “proximal” refers to the opposite direction (e.g., the proximal end of the catheter is inserted into the distal end of the connector).

Generally, the present disclosure is directed to an echogenic coil member for a catheter assembly and methods of manufacturing same. The catheter assembly includes a catheter having a proximal end and a distal end that defines a lumen extending from the proximal end to the distal end.
20 As such, the coil member may be configured within the lumen of the catheter. More specifically, the coil member includes a plurality of outwardly extending projections that contain a plurality of discontinuities on an outer surface thereof. Thus, the discontinuities are configured to enhance ultrasonic imaging of the catheter assembly.

Referring now to the drawings, FIGS. 1 and 2 illustrate various embodiments of an echogenic
25 catheter assembly 10 according to the present disclosure. For example, as shown, the catheter assembly 10 includes a catheter 14 having a proximal end 22 and a distal end 24 coaxially mounted onto a needle 12. In certain embodiments, as shown in FIG. 1, the catheter assembly 10 may be an over-the-needle (OTN) catheter assembly, i.e. the catheter 14 is coaxially mounted to the needle 12. Thus, the catheter assembly 10 may be configured such that the catheter 14 and needle 12 can be
30 simultaneously inserted into a patient. In addition, the catheter 14 (and/or the needle 12) defines a lumen 26 extending from the proximal end 22 to the distal end 24 of the catheter 14. Thus, the catheter 14 is configured to deliver a treatment fluid to a targeted site within the patient via the lumen 26. More specifically, as shown in FIG. 1, the catheter assembly 10 may include an open distal tip 28 such that the needle 12 may extend beyond the open distal tip 28. In addition, the proximal end 22 of

the catheter 14 may include a hub 16 configured thereon for mating communication with a fluid delivery device (not shown) such that a treatment fluid can be delivered to a targeted site within a patient via the lumen 26 and the open distal tip 28 of the catheter 14. The fluid delivery device may be any suitable device known in the art, such as a pump, reservoir, syringe, or the like. Further, the hub
5 16 may have any conventional configuration, such as a Luer-lock fitting.

In additional embodiments, as shown in FIGS. 2 and 5, the catheter assembly 10 may include a closed distal tip 29, e.g. depending on the desired delivery application of the treatment fluid to the patient. More specifically, as shown, the catheter assembly 10 may include a closed distal tip 29 without the needle 12. In such an embodiment, the catheter 14 may contain one or more infusion
10 holes 25 configured to deliver a treatment fluid to a targeted site within a patient via the lumen 26 of the catheter 14. In addition, it should also be understood that the OTN catheter assemblies as described herein may optional include one or more infusion holes in addition to the open distal tip 28 for administering a treatment fluid to a patient.

Still referring to FIGS. 1 and 2, the echogenic catheter assembly 10 may also include a heat
15 application assembly 50 configured to apply heat to the catheter 14. For example, as shown, the heat application assembly 50 may be coupled with the hub 16 of the catheter 14 so as to apply heat or current to the catheter 14. In further embodiments, the heat application assembly 50 may be directly coupled to the catheter 14 (or the needle 12 where applicable) or any other suitable component of the catheter assembly 10, e.g. the wire and/or coil members 30, 35 as described herein. Further, the heat
20 application assembly 50 may correspond to a nerve stimulator apparatus having a nerve stimulator 52 that provides heat or current through one or more stimulator wires 54. It should be understood, however, that the heat application assembly 50 can further include any other suitable heating assembly known in the art and the illustrated embodiment is provided for illustrative purposes only. For example, in further embodiments, the heat application assembly 50 may also include one or more
25 battery devices, temperature-controlled water, an ultrasound device, a vibration device, or similar.

As shown generally in FIGS. 3-10, the echogenic catheter assembly 10 also includes an echogenic wire member 30 or an echogenic coil member 35 configured to enhance ultrasonic imaging of the catheter assembly 10. In addition, the wire and/or coil members 30, 35 are configured to provide support to the catheter 14 as the catheter 14 is being inserted within a patient and/or during a
30 medical procedure. Thus, in certain embodiments, the nerve stimulator apparatus 50 (FIG. 1) may be configured to apply current through the wire and/or coil members 30, 35 for use during various medical procedures.

Referring particularly to FIGS. 3 and 4, the wire member 30 or stylet defines an outer surface 34 extending from a proximal end 32 to a distal end 33. Further, as shown, the distal end 33 of the

wire member 30 may include one or more discontinuities configured to enhance ultrasonic imaging of the catheter assembly 10. More specifically, as shown, the distal end 33 of the wire member 30 may include one or more laser-etched discontinuities 40 that enhance ultrasonic imaging of the catheter assembly 10.

5 Referring now to FIGS. 5-9, the echogenic catheter assembly 10 may also include an echogenic coil member 35 configured to enhance ultrasonic imaging of the catheter assembly 10. More specifically, as shown in FIG. 5, the coil member 35 may include one or more discontinuities 40 that are configured to enhance ultrasonic imaging of the catheter assembly 10. Further, as shown, the coil member 35 may be sized to fit within the lumen 26 of the catheter, e.g. such that the coil member
10 35 can be easily inserted therethrough. Alternatively, the coil member 35 may be embedded into an interior wall of the catheter 14. More specifically, as shown, the coil member 35 may be completely embedded within the interior wall of the lumen 26 of the catheter 14 such that the internal diameter of the catheter 14 remains unchanged and the needle 12 (if present) can easily fit therethrough. In alternative embodiments, the coil member 35 may be partially embedded within the interior wall of the
15 catheter 14 of the lumen 26 of the catheter 14.

Referring particularly to FIGS. 6-9, the coil member 35 includes a plurality of outwardly extending projections 36 that contain the plurality of discontinuities 40 on an outer surface 38 thereof. For example, as shown, the discontinuities 40 may be located at a distal region of the coil member 35, e.g. at a distal end 37 of the coil member 35. In further embodiments, the discontinuities 40 may be
20 located at any suitable location along a length of the coil member 35.

In addition, as shown in FIGS. 5-7, at least a portion of the coil member 35 may be in a compressed position 44 such that adjacent outwardly extending projections 39 of the compressed portion 44 contact each other. Thus, as shown in FIGS. 6 and 7, one or more discontinuities 40 of contacting adjacent outwardly extending projections 39 may connect to form a larger discontinuity 42.
25 In alternative embodiments, as shown in FIGS. 5 and 8-9, at least a portion of the coil member 35 may be in an expanded position 46 such that adjacent outwardly extending projections 39 of the expanded portion 46 are spaced apart from each other. As such, one or more discontinuities 40 of spaced-apart outwardly extending projections 39 are also spaced apart from each other. In further embodiments, the compressed and extended portions of the coil member 35 may contain one or more discontinuities
30 40.

In additional embodiments, the discontinuities 40 of the echogenic wire or coil members 30, 35 may include any suitable discontinuities having any suitable size and/or shape arranged in any suitable pattern so as to provide enhanced ultrasonic imagine. For example, in certain embodiments, the discontinuities 40 may include at least one or more of the following: indentations, grooves, notches,

recesses, threads, protrusions, or similar. Further, in certain embodiments, the discontinuities 40 may be arranged in a predetermined pattern so as to enhance ultrasonic imaging of the catheter assembly 10. In one embodiment, for example, the predetermined pattern may include organized rows and/or columns of discontinuities. Alternatively, the pattern of discontinuities 40 may be random. More particularly, in certain embodiments, the discontinuities 40 may have a generally round shape with flat bottoms and flat sides. In further embodiments, the discontinuities 40 may include a first spherical indentation and a second spherical indentation contained within the first indentation to enhance ultrasonic imaging, e.g. as described in U.S. Patent Application Publication No.: 2014/0378841 entitled "Echogenic Article with Compound Discontinuities" filed on June 18, 2014, which is herein incorporated by reference in its entirety.

In further embodiments, the discontinuities 40 of the echogenic wire or coil members 30, 35 may be manufactured using any suitable means. For example, in certain embodiments, the discontinuities 40 may be manufactured using laser etching, spatter techniques (i.e. displacement of metal and/or other phenomena), cutting, machining, or similar.

In additional embodiments, the wire or coil members 30, 35 may be constructed of any suitable echogenic material. For example, in specific embodiments, the echogenic wire or coil members 30, 35 may be constructed of a metal or a metal alloy. More particularly, the metal or metal alloy may include at least one of or a combination of the following: aluminum, titanium, copper, tin, nickel, zinc, magnesium, stainless steel, or similar.

Referring now to FIG. 10, a flow diagram of one embodiment of a method 100 for manufacturing an echogenic catheter assembly 10 according to the present disclosure is illustrated. As shown at 102, the method 100 includes providing a catheter 14 that defines a lumen 26 extending from a proximal end 22 to a distal end 24 thereof. As shown at 104, the method 100 includes coiling a wire member 30 so as to form a coil member 35 having a plurality of outwardly extending projections 36. As shown at 106, the method 100 includes forming a plurality of discontinuities 40 onto an outer surface 38 of the outwardly extending projections 36 so as to enhance ultrasonic imaging of the catheter assembly 10. As shown at 108, the method 100 includes inserting the coil member 35 into the lumen 26 of the catheter 14 so as to form the catheter assembly 10. In addition, it should be understood that the method steps as described herein may be performed in any suitable order. For example, in additional embodiments, the discontinuities 40 may be formed onto the wire member 30 before the wire member 30 is formed into the coil member 35.

In further embodiments, the method 100 may also include forming the plurality of discontinuities 40 onto a distal region of the outer surface 38 of the outwardly extending projections 36. In additional embodiments, the method 100 may include compressing at least a portion of the coil

member 35 such that adjacent outwardly extending projections 36 of the compressed position 44 contact each other. Thus, the method 100 may also include forming one or more discontinuities 40 onto the outer surface 38 of contacting adjacent outwardly extending projections 39 to form one or more larger discontinuities 42. More specifically, in certain embodiments, the method 100 may include
5 laser etching one or more discontinuities 40 onto the outer surface 38 of contacting adjacent outwardly extending projections 39.

In alternative embodiments, the method 100 may also include expanding at least a portion of the coil member such that adjacent outwardly extending projections 39 of the expanded portion 46 are spaced apart from each other. Thus, the method 100 may also include forming one or more
10 discontinuities 40 onto the outer surface 38 of the spaced-apart adjacent outwardly extending projections 39.

This written description uses examples to disclose the invention, including the best mode, and also to enable any person skilled in the art to practice the invention, including making and using any devices or systems and performing any incorporated methods. The patentable scope of the invention
15 is defined by the claims, and may include other examples that occur to those skilled in the art. Such other examples are intended to be within the scope of the claims if they include structural elements that do not differ from the literal language of the claims, or if they include equivalent structural elements with insubstantial differences from the literal languages of the claims.

WHAT IS CLAIMED IS:

1. An echogenic catheter assembly, comprising:
a catheter comprising a proximal end and a distal end and defining a lumen extending from the proximal end to the distal end; and,
5 a coil member configured within the lumen of the catheter, the coil member forming a plurality of outwardly extending projections, the outwardly extending projections comprising a plurality of discontinuities configured to enhance ultrasonic imaging.
2. The catheter assembly of claim 1, wherein the plurality of discontinuities are located at a distal region of coil member.
- 10 3. The catheter assembly of claim 1, wherein at least a portion of the coil member is in a compressed position such that adjacent outwardly extending projections of the compressed portion contact each other.
4. The catheter assembly of claim 3, wherein one or more discontinuities of contacting adjacent outwardly extending projections connect to form a larger discontinuity.
- 15 5. The catheter assembly of claim 1, wherein at least a portion of the coil member is in an expanded position such that adjacent outwardly extending projections of the expanded portion are spaced apart from each other.
6. The catheter assembly of claim 1, wherein the coil member is embedded into an interior wall of the catheter.
- 20 7. The catheter assembly of claim 1, wherein the discontinuities comprises at least one or more of the following: indentations, grooves, notches, recesses, threads, or protrusions.
8. The catheter assembly of claim 1, wherein the discontinuities are laser-etched into the coil member.
9. The catheter member of claim 1, wherein the coil member is constructed of a metal or
25 metal alloy, wherein the metal or metal alloy comprises at least one of or a combination of the following: aluminum, titanium, copper, tin, nickel, zinc, magnesium, or stainless steel.
10. The catheter assembly of claim 1, wherein the catheter comprises a closed distal tip one or more infusion holes, and wherein the infusion holes allow a medication flowing through the lumen of the catheter to exit therethrough.
- 30 11. The catheter assembly of claim 1, further comprising a needle configured within a lumen of the coil member.
12. The catheter assembly of claim 11, wherein the distal end of the catheter comprises an open distal tip, and wherein the needle is configured to extend past the open distal tip.

13. A method for manufacturing an echogenic catheter assembly, the method comprising: providing a catheter defining a lumen that extends from a proximal end to a distal end thereof; etching a plurality of discontinuities onto a wire member;

5 coiling the wire member so as to form a coil member having a plurality of outwardly extending projections, wherein the plurality of discontinuities are exposed on an outer surface of the plurality of outwardly extending projections so as to enhance ultrasonic imaging; and, inserting the coil member into the lumen of the catheter.

14. A method for manufacturing an echogenic catheter assembly, the method comprising: providing a catheter having a lumen that extends from a proximal end to a distal end thereof;

10 coiling a wire member so as to form a coil member having a plurality of outwardly extending projections;

forming a plurality of discontinuities onto an outer surface of the outwardly extending projections so as to enhance ultrasonic imaging; and,

inserting the coil member into the lumen of the catheter.

15 15. The method of claim 14, further comprising forming the plurality of discontinuities onto a distal region of the outer surface of the outwardly extending projections.

16. The method of claim 14, further comprising:

compressing at least a portion of the coil member such that adjacent outwardly extending projections of the compressed portion contact each other, and

20 forming one or more discontinuities onto the outer surface of contacting adjacent outwardly extending projections to form one or more larger discontinuities.

17. The method of claim 14, further comprising:

expanding at least a portion of the coil member such that adjacent outwardly extending projections of the expanded portion are spaced apart from each other, and

25 forming one or more discontinuities onto the outer surface of the spaced-apart adjacent outwardly extending projections.

18. The method of claim 14, wherein the discontinuities comprises at least one or more of the following: indentations, grooves, notches, recesses, threads, or protrusions.

30 19. The method of claim 14, further comprising laser-etching the plurality of discontinuities onto the outer surface of the outwardly extending projections.

20. The method of claim 14, wherein the coil member is constructed of a metal or metal alloy, wherein the metal or metal alloy comprises at least one of or a combination of the following: aluminum, titanium, copper, tin, nickel, zinc, magnesium, or stainless steel.

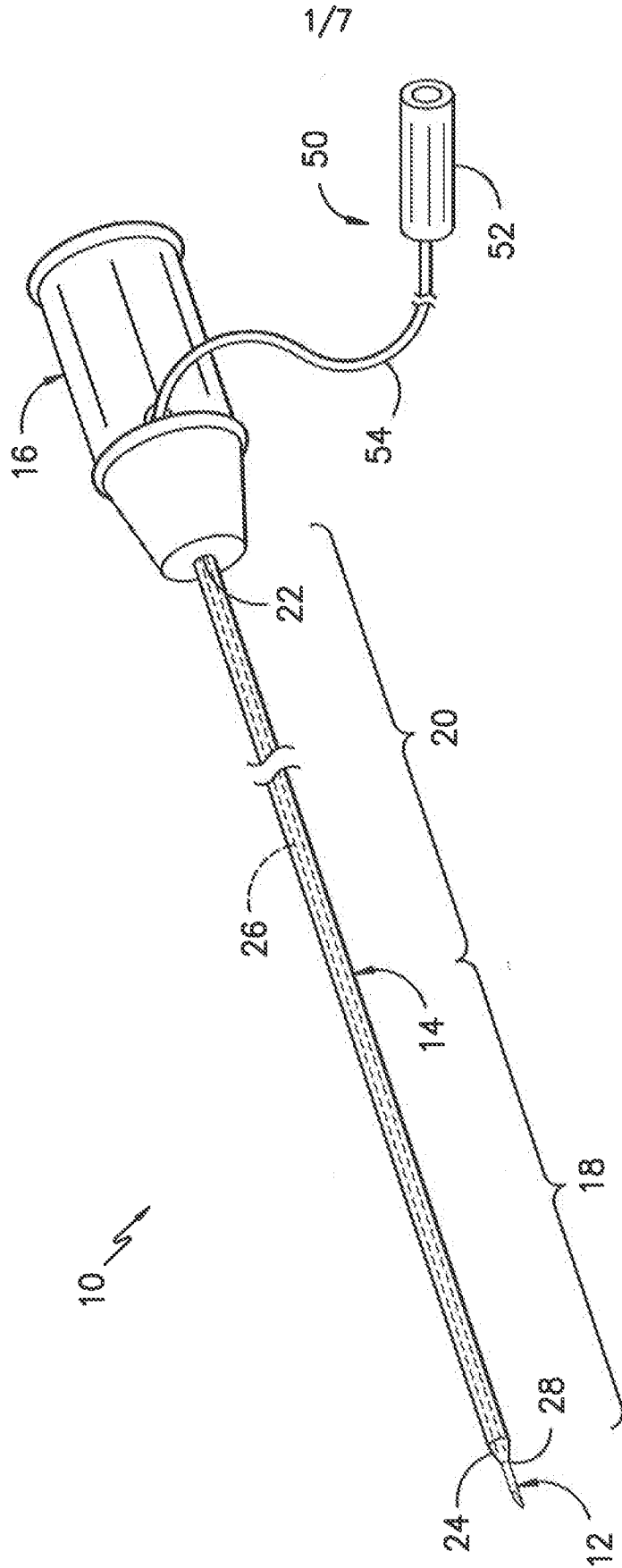

FIG. -1-

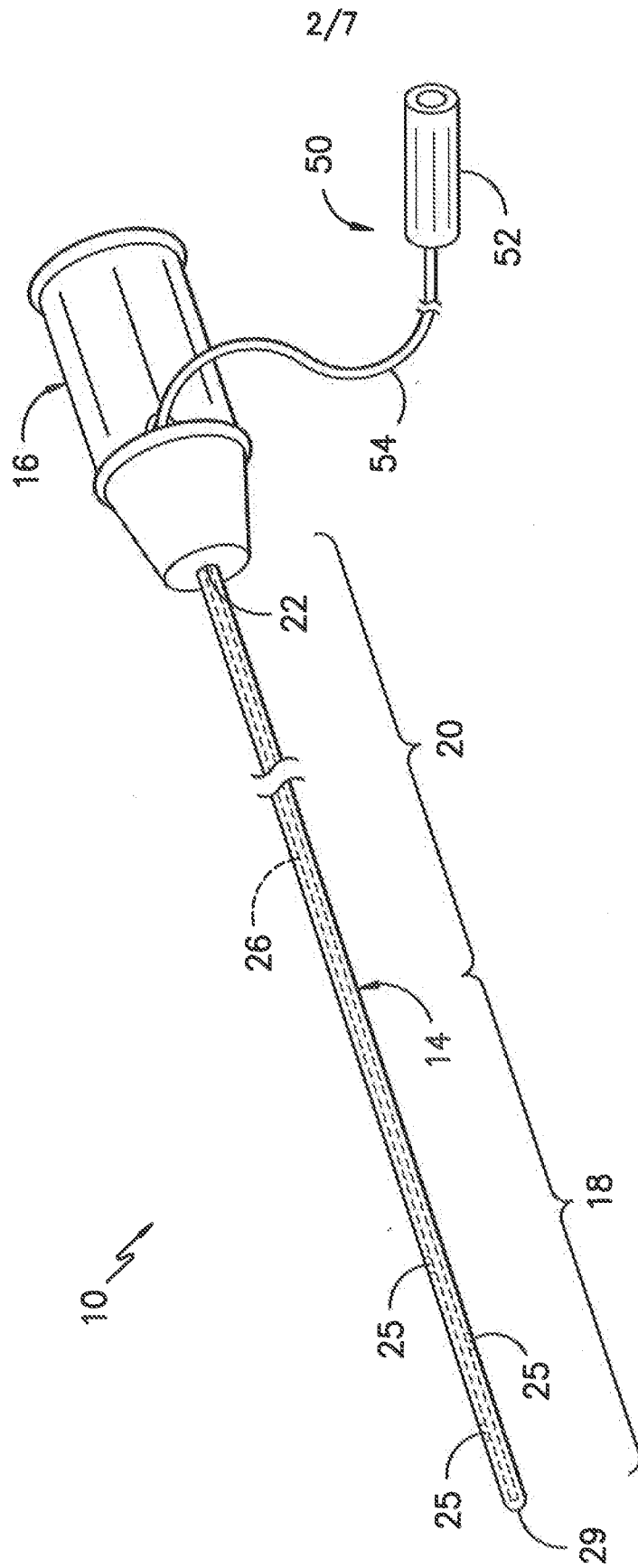

FIG. -2-

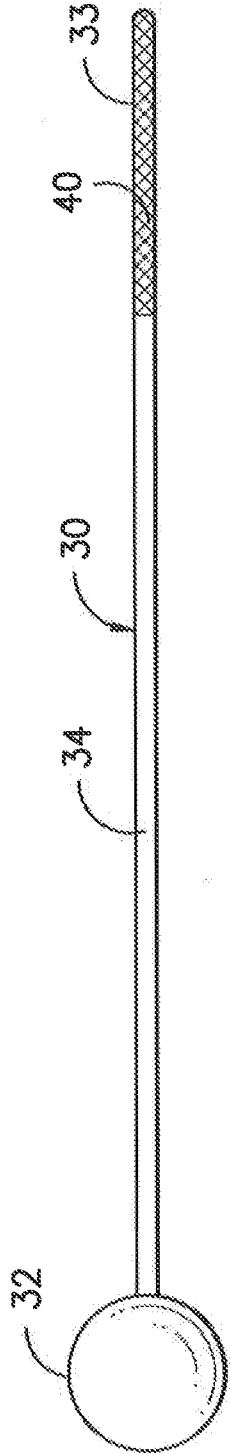

FIG. -3-

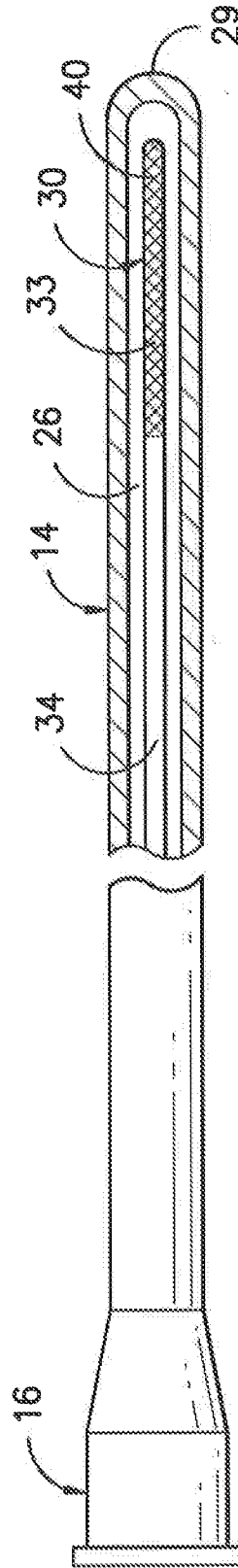

FIG. -4-

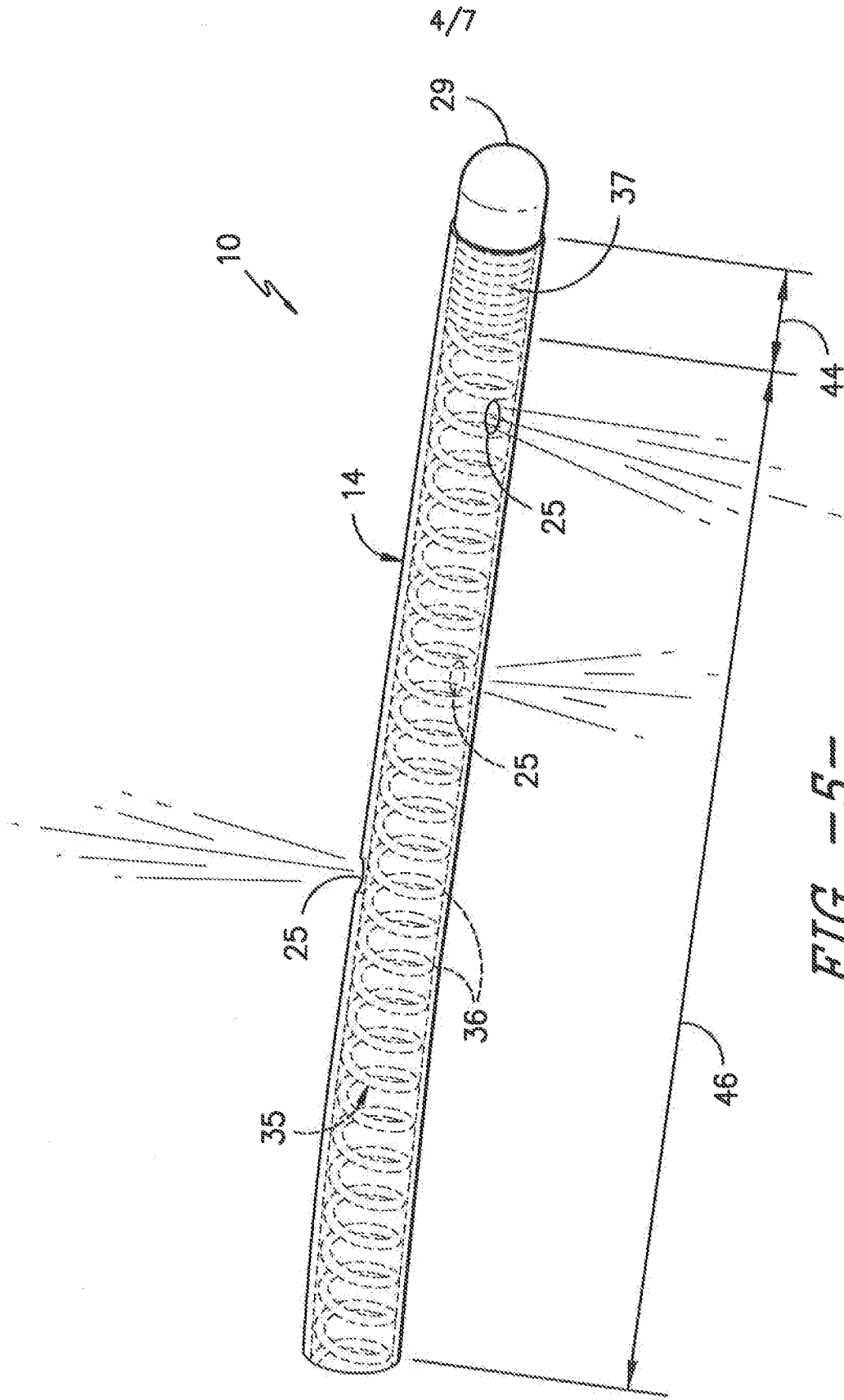

FIG. -5-

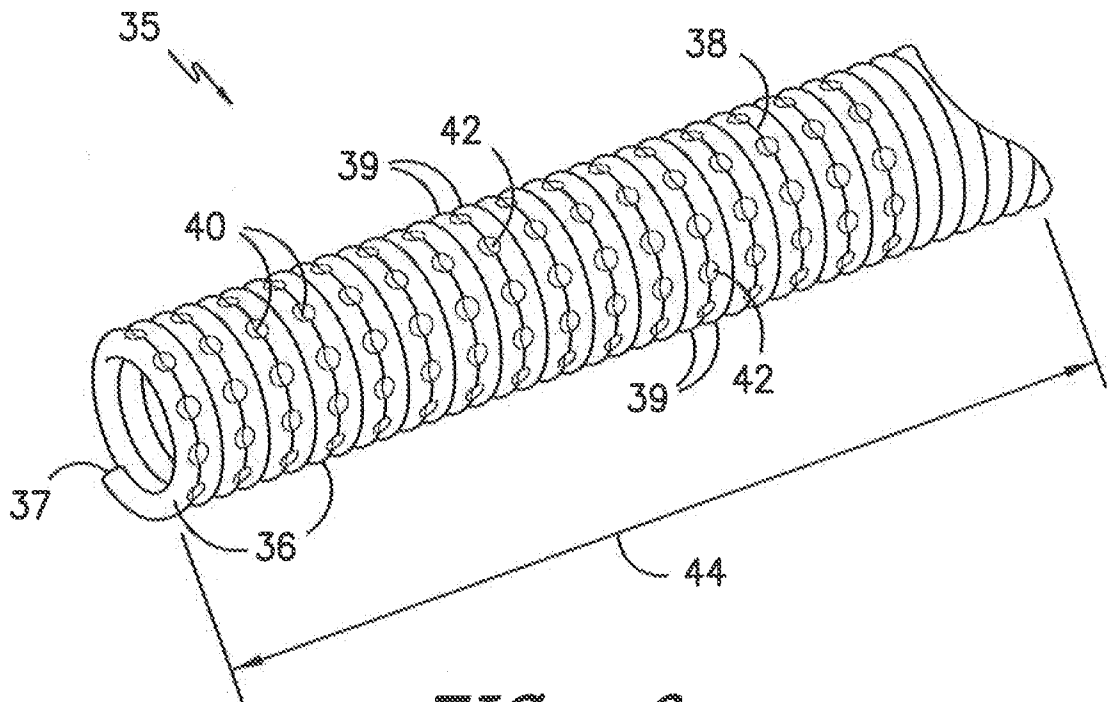

FIG. -6-

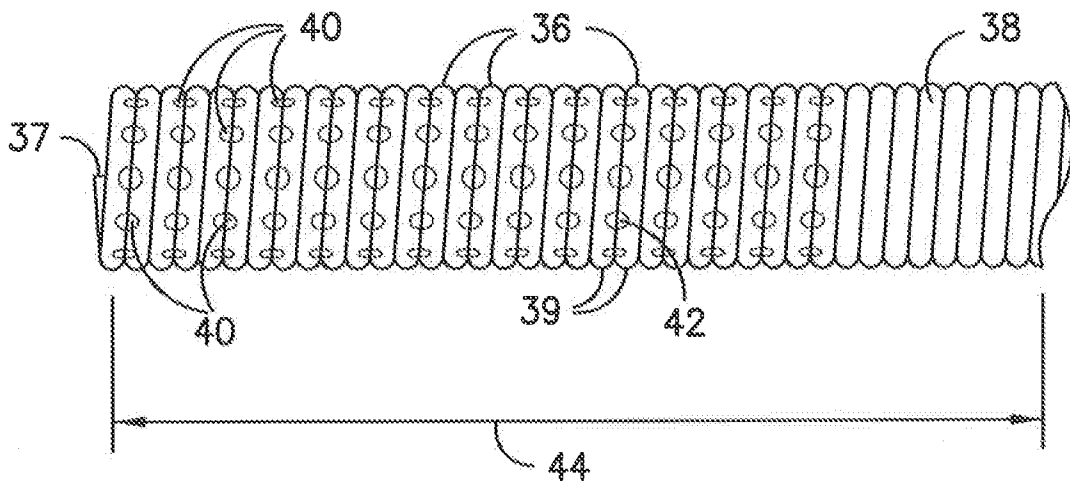

FIG. -7-

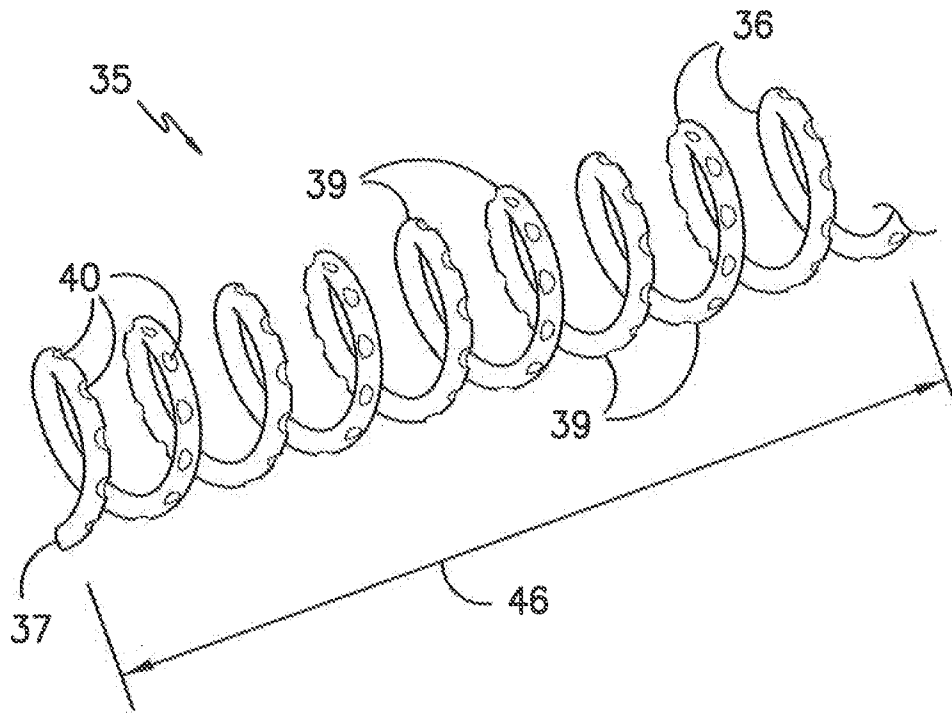

FIG. -8-

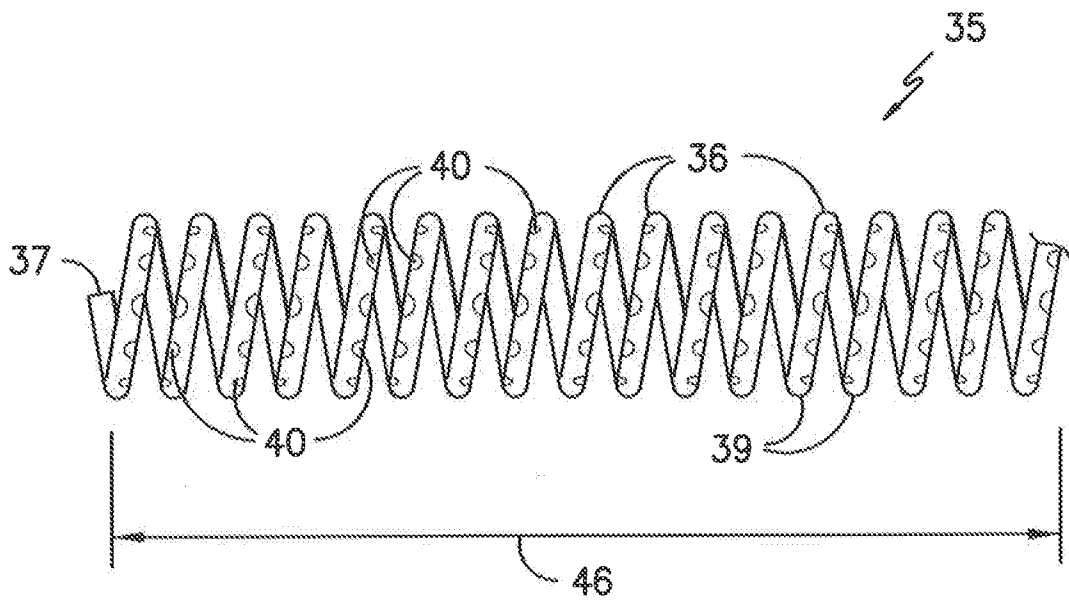
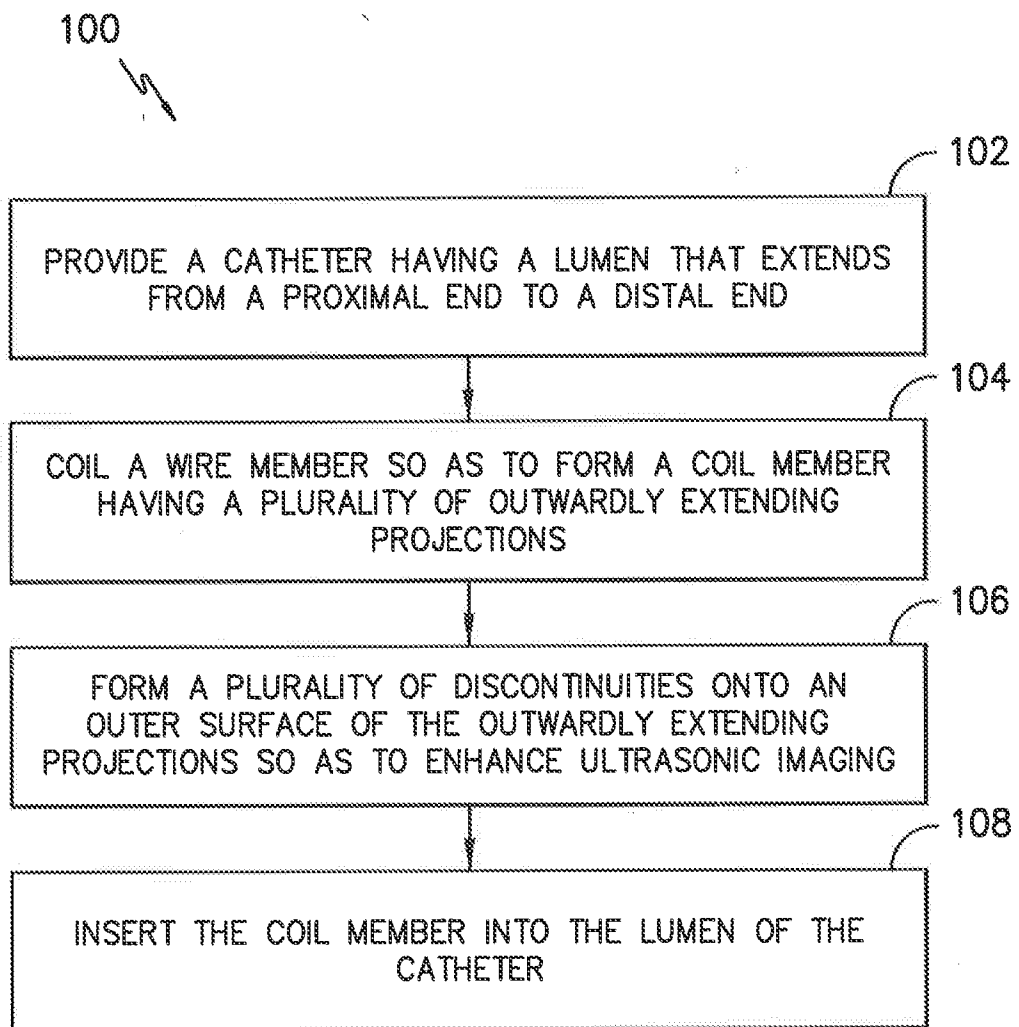

FIG. -9-

7/7

*FIG. -10-*

INTERNATIONAL SEARCH REPORT

International application No
PCT/US2015/036363

A. CLASSIFICATION OF SUBJECT MATTER
INV. A61M25/00 A61M25/01 A61B90/00
ADD.
According to International Patent Classification (IPC) or to both national classification and IPC

B. FIELDS SEARCHED
Minimum documentation searched (classification system followed by classification symbols)
A61M A61B

Documentation searched other than minimum documentation to the extent that such documents are included in the fields searched

Electronic data base consulted during the international search (name of data base and, where practicable, search terms used)
EPO-Internal, WPI Data

C. DOCUMENTS CONSIDERED TO BE RELEVANT

Category*	Citation of document, with indication, where appropriate, of the relevant passages	Relevant to claim No.
X	US 2012/095404 A1 (MASSENGALE ROGER DILLARD [US] ET AL) 19 April 2012 (2012-04-19)	1,2,5-13
Y	paragraphs [0020], [0057], [0072], [0083]; figures 4-11	3,4
X	US 2008/058702 A1 (ARNDT GEORGE A [US] ET AL) 6 March 2008 (2008-03-06)	1,2,5-9, 14-20
Y	paragraphs [0035], [0053], [0059], [0060]; figures 8,9	3,4
Y	EP 2 343 098 A1 (CUSTOM MED APPLICATIONS INC [US]) 13 July 2011 (2011-07-13)	3,4
	paragraphs [0033], [0034]; figures 3,5,6	
	-/--	

Further documents are listed in the continuation of Box C.

See patent family annex.

* Special categories of cited documents :

"A" document defining the general state of the art which is not considered to be of particular relevance

"E" earlier application or patent but published on or after the international filing date

"L" document which may throw doubts on priority claim(s) or which is cited to establish the publication date of another citation or other special reason (as specified)

"O" document referring to an oral disclosure, use, exhibition or other means

"P" document published prior to the international filing date but later than the priority date claimed

"T" later document published after the international filing date or priority date and not in conflict with the application but cited to understand the principle or theory underlying the invention

"X" document of particular relevance; the claimed invention cannot be considered novel or cannot be considered to involve an inventive step when the document is taken alone

"Y" document of particular relevance; the claimed invention cannot be considered to involve an inventive step when the document is combined with one or more other such documents, such combination being obvious to a person skilled in the art

"&" document member of the same patent family

Date of the actual completion of the international search 15 February 2016	Date of mailing of the international search report 22/02/2016
---	--

Name and mailing address of the ISA/ European Patent Office, P.B. 5818 Patentlaan 2 NL - 2280 HV Rijswijk Tel. (+31-70) 340-2040, Fax: (+31-70) 340-3016	Authorized officer Bielsa, David
--	-------------------------------------

INTERNATIONAL SEARCH REPORT

International application No
PCT/US2015/036363

C(Continuation). DOCUMENTS CONSIDERED TO BE RELEVANT		
Category*	Citation of document, with indication, where appropriate, of the relevant passages	Relevant to claim No.
A	EP 2 540 336 A1 (ASAHI INTECC CO LTD [JP]) 2 January 2013 (2013-01-02) paragraphs [0024] - [0035]; figures 1a,1b,2a,2b	1-20
L	----- US 2004/077948 A1 (VIOLANTE MICHAEL R [US] ET AL) 22 April 2004 (2004-04-22) paragraphs [0012], [0013], [0094] -----	13

INTERNATIONAL SEARCH REPORT

Information on patent family members

International application No PCT/US2015/036363

Patent document cited in search report	Publication date	Patent family member(s)	Publication date	
US 2012095404	A1	19-04-2012	AU 2011319493 A1	11-04-2013
			CA 2811736 A1	26-04-2012
			CN 103167835 A	19-06-2013
			EP 2629671 A2	28-08-2013
			EP 2724672 A1	30-04-2014
			ES 2523389 T3	25-11-2014
			JP 2013543410 A	05-12-2013
			KR 20130142117 A	27-12-2013
			RU 2013119467 A	27-11-2014
			US 2012095404 A1	19-04-2012
WO 2012052907 A2	26-04-2012			

US 2008058702	A1	06-03-2008	EP 2152185 A1	17-02-2010
			JP 2010528769 A	26-08-2010
			US 2008058702 A1	06-03-2008
			WO 2008154200 A1	18-12-2008

EP 2343098	A1	13-07-2011	CA 2726418 A1	12-07-2011
			EP 2343098 A1	13-07-2011
			JP 5775689 B2	09-09-2015
			JP 2011143245 A	28-07-2011
			KR 20110083528 A	20-07-2011
			US 2011172542 A1	14-07-2011

EP 2540336	A1	02-01-2013	CN 102847225 A	02-01-2013
			EP 2540336 A1	02-01-2013
			JP 2013013449 A	24-01-2013
			US 2013006221 A1	03-01-2013

US 2004077948	A1	22-04-2004	CA 2536947 A1	10-03-2005
			EP 1663108 A2	07-06-2006
			JP 2007503263 A	22-02-2007
			US 2004077948 A1	22-04-2004
			US 2007255140 A1	01-11-2007
			WO 2005020905 A2	10-03-2005
