

(No Model.)

4 Sheets—Sheet 1.

J. BROOKS.

SET-OFF MECHANISM FOR PRINTING PRESSES.

No. 438,342.

Patented Oct. 14, 1890.

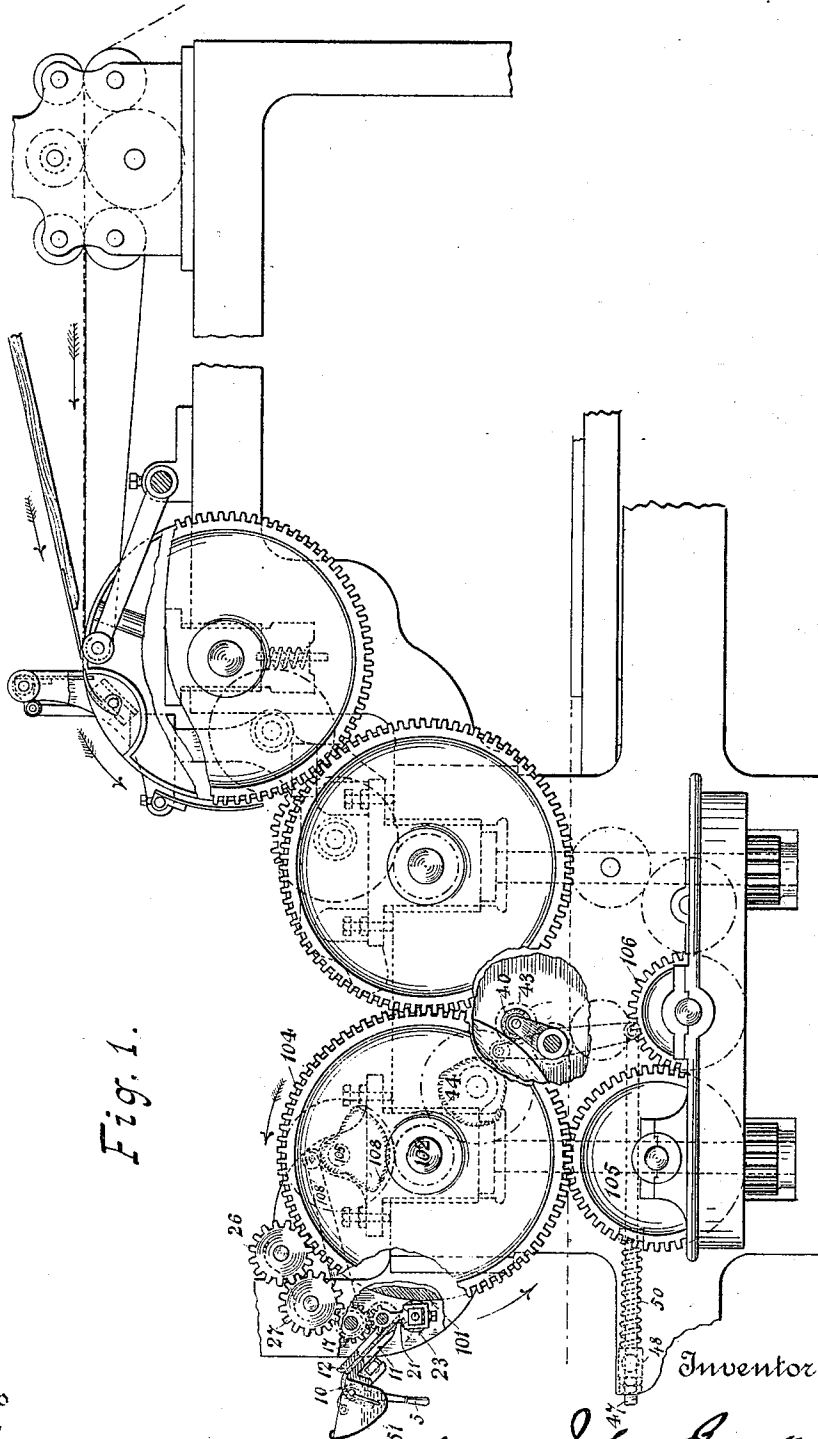

Fig. 1.

Witnesses  
Chas Hanemann  
H. F. Parker

Inventor  
John Brooks  
By his Attorney  
Chas W. Corlier



J. BROOKS.

SET-OFF MECHANISM FOR PRINTING PRESSES.

No. 438,342.

Patented Oct. 14, 1890.

Fig. 3.

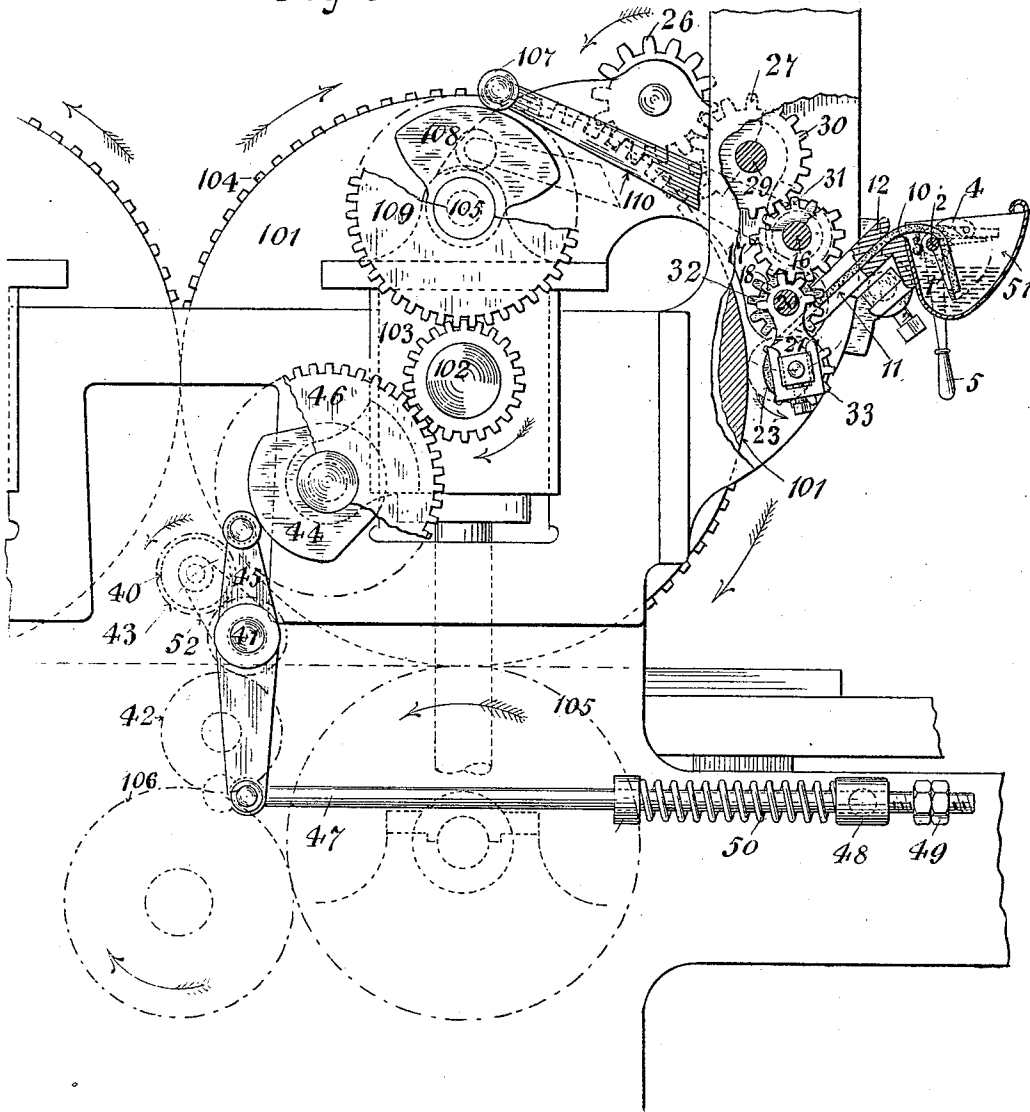

Witnesses  
 Chas. Hanemann  
 H. F. Peters.

Inventor  
*John Brooks*  
 By his Attorney  
*Chas. W. Corbin*

J. BROOKS.

SET-OFF MECHANISM FOR PRINTING PRESSES.

No. 438,342.

Patented Oct. 14, 1890.

Fig. 4.

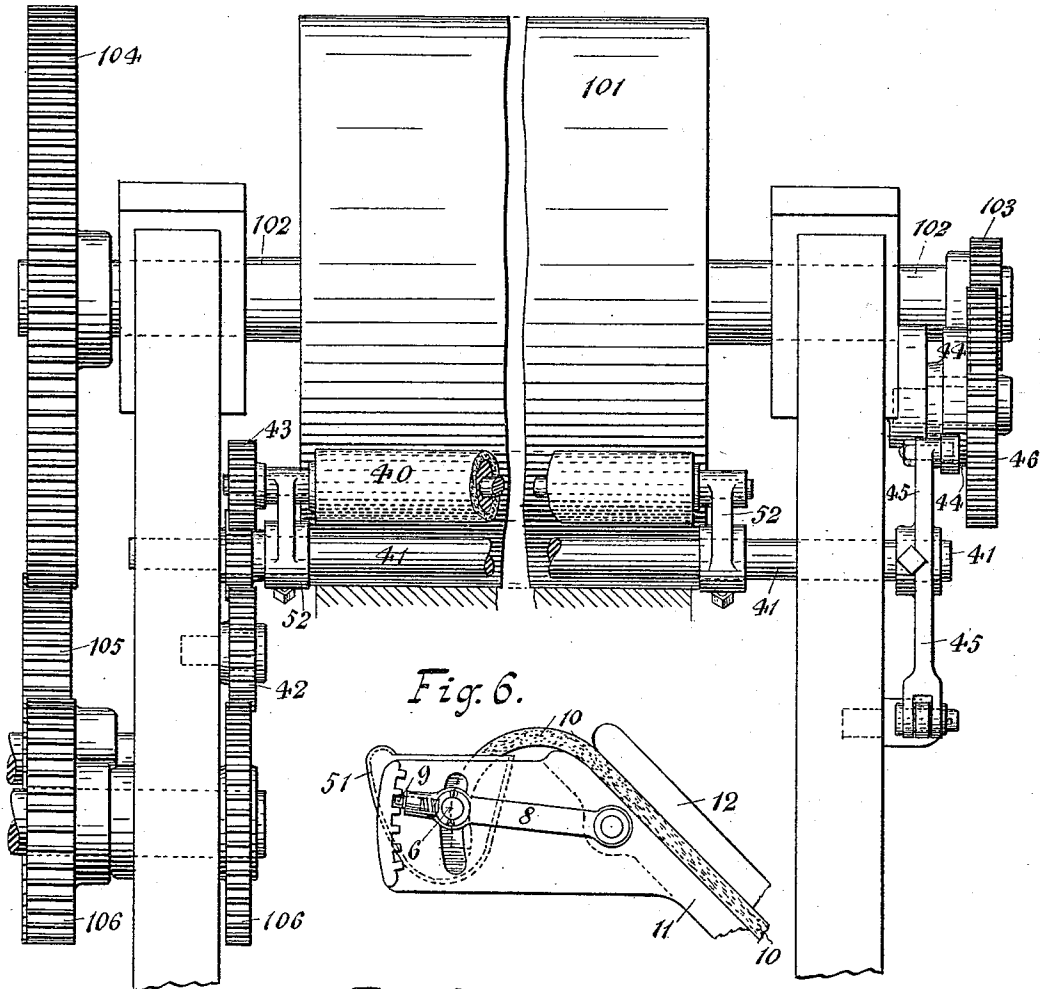

Fig. 6.

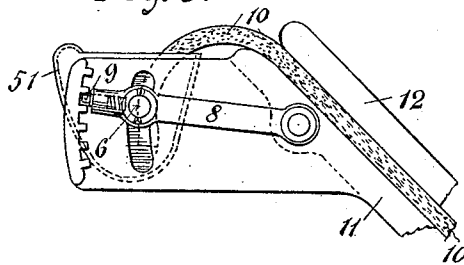
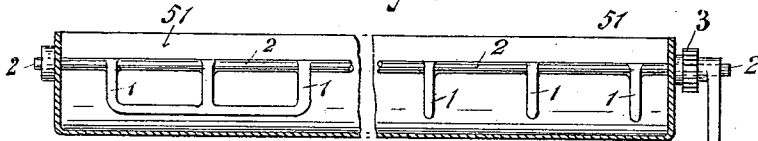

Fig. 5.



Witnesses  
*Chas. Hammann*  
*H. F. Parker.*

Inventor  
*John Brooks*  
 By his Attorney  
*Chas. W. Dyer*

# UNITED STATES PATENT OFFICE.

JOHN BROOKS, OF PLAINFIELD, NEW JERSEY.

## SET-OFF MECHANISM FOR PRINTING-PRESSES.

SPECIFICATION forming part of Letters Patent No. 438,342, dated October 14, 1890.

Application filed April 22, 1890. Serial No. 348,960. (No model.)

*To all whom it may concern:*

Be it known that I, JOHN BROOKS, a citizen of the United States, residing at Plainfield, in the county of Union and State of New Jersey, have invented certain new and useful Improvements in a Set-Off Mechanism for Printing-Presses, fully set forth in the following specification and represented in the accompanying drawings.

This invention relates more especially to devices employed with web-perfecting printing-presses, or to that class of presses wherein both sides of the sheet or web are printed or perfected in passing once through the press. In some cases, however, such devices may be employed with single-cylinder printing-presses wherein the second side of the sheet is printed; and it has for its object to provide means whereby what is technically known as "set-off" may be prevented, rendering the completed work neater and free from stains.

To this end the present consists, first, in an improvement upon the devices set forth in Letters Patent of the United States, granted to me March 28, 1890, No. 423,660, or upon analogous devices, embracing, in combination with a liquid-feeder, such as set forth in said patent, of a means for regulating the amount of liquid drawn by or taken up by the feeder, whereby, for example, the absorbent material of the feeder absorbs more or less of the liquid and whereby the absorption may be wholly stopped.

It furthermore consists in combination, with a set-off mechanism or device and the cylinder upon which the liquid is deposited, of a counter or opposing absorption roll or device coacting with the surface of the cylinder, whereby an accumulation or surplus of the liquid on said cylinder is absorbed and removed.

It also consists in mechanism for operating this counter absorption roll or device, whereby it acts to absorb the liquid from the cylinder surface at the proper time, and otherwise coacts with the printing devices, all of which will be fully hereinafter set forth.

In the accompanying drawings, which illustrate a practical embodiment of the invention, Figure 1 is a side elevation of so much of a

cylinder perfecting printing-press as is necessary to show the connection of the present improvements with a well-known type of press. Fig. 2 is an enlarged elevation of an impression-cylinder with the present improvements combined therewith, certain of the parts being broken away in section for perspicuity's sake. Fig. 3 is an opposite side elevation of a portion of the machine shown in Fig. 1, illustrating particularly the means for causing the counter absorption-roll to move into and out of surface contact with the cylinder. Fig. 4 is a transverse elevation of the cylinder counter absorption-roll and connecting devices broken away and foreshortened for accommodating it to the space of the sheet. Figs. 5 and 6 show modifications.

Referring to the drawings, particularly to Figs. 1, 2, 3, and 4, it will be understood that 101 represents the impression-cylinder of a perfecting or other class of printing press or machine; 102, its shaft, one end whereof is provided with a toothed wheel 104, meshing with an intermediate wheel 105, which in turn meshes with a driving-wheel 106, by which the cylinder is properly rotated. As in my said patent and as shown in Fig. 2, the liquid-feeder consists, preferably, of a sheet of felt or other liquid-absorbing medium 10, held or clamped between the surfaces of a pair of plates 11 12, extending transversely across the machine and approximately the width of the impression-cylinder. One of the plates, as 12, is supported by a transverse rock-shaft 13, mounted in the frame-work that is provided with a rock-arm 110, the outer end of which carries a roll 107, which bears upon the periphery of a cam 108. This cam is mounted upon a stud 105, projecting from one of the boxes carrying the cylinder-shaft 102, and is secured to the inner face or hub of a toothed wheel 109, that meshes with a similar wheel 103, fast to the end of the cylinder-shaft opposite the toothed wheel 104. The construction and operation of these parts are such that the edge of the felt 10, adjacent to the impression-cylinder, is caused to advance or retract into or from contact therewith at the proper times. Instead, however, of allowing the felt to retract directly from the surface of the impression-cylinder, it is preferred to

interpose between the edge of said felt and the surface of the cylinder an intermediate or distributing roll 23, as shown in Fig. 3, that is hung at the end of arms 21, pivoted upon and projecting from a transverse rock-shaft 20. The face of said distributing-roll is provided with a layer of plush or equivalent material, and is arranged to constantly impinge the edge of the felt 10 and at stated times move in and from contact with the surface of the impression-cylinder. This movement of the distributing-roll is effected through the movement of the rock-shaft 16 by means of toothed wheels 17 fast to the ends of said rock-shaft and an intermediate wheel or segment 18, mounted on the shaft 20, in gear with said wheels 17 and forming a part of the arms 21.

Continuous motion may be imparted to the distributing-roll 23 from the cylinder-wheel 104 through a transmitting wheel 26 in gear therewith and mounted upon a stud projecting from the machine-frame, and a second intermediate 27 fast to the outer end of a cross-shaft 29. To the opposite end of the cross-shaft 29 there is fast a toothed wheel 30, that is in gear with a similar wheel 31, loose upon the rock-shaft 16. With the last-named wheel a toothed wheel 32 engages, which is loose upon the cross-shaft 20, that in turn is in gear with a similar wheel 33, fast to the distributing-roll shaft, all as fully set forth in my said patent.

A portion or one end of the liquid-feeding felt 10 extends over the end of one of the supporting-plates, as 11, into a liquid receptacle or reservoir 51, which is preferably secured to said plate, so as to partake of its movements, although, as is obvious, this is not essential. In order to vary the extent to which this end of the felt shall project into the liquid, there is provided means for adjusting the felt with respect to the liquid in the reservoir, or adjusting the reservoir or the height of the liquid therein with respect to the felt.

In one form of the invention, as shown in Fig. 2, there is provided a lifter for the felt, consisting of a transverse plate 1, projecting from a rock-shaft 2, that extends longitudinally of the reservoir 51 and mounted in bearings in the ends thereof. The end of the felt is led over the lifter 1, which may extend more or less within the reservoir, so that when the lifter is rocked in one direction by means of its shaft it will move the felt more or less or wholly from the liquid, and when moved in the opposite direction it will permit the felt to project into the liquid a greater or less extent. Thus if only a small quantity of liquid is desired to be fed to the feeder, the lifter will be moved so that a very small portion of the felt will extend into the liquid. When the amount of liquid to be fed is to be increased, the lifter will be moved so that the end of the felt will project deeper into the liquid, and when the supply of liquid is to be still further decreased or entirely stopped

the lifter will be moved so as to raise the felt entirely from the liquid, as will be found desirable, when the press is at rest, whereby the liquid is used more economically. Instead of the lifter being formed of a plate, it may be of skeleton form or formed of a plurality of fingers extending from the rock-shaft 2, as shown in Fig. 5. In order to hold the lifter in any position to which it may be adjusted, the end of the rock-shaft 2 is provided with a ratchet 3, that is engaged by a pawl 4, pivotally mounted on the end of the reservoir, and as a convenient means of moving the lifter an operating-handle 5 may be secured to the outer end of the rock-shaft 2.

In another form of the invention, as shown in Fig. 6, the reservoir 51 is movable with respect to the felt, so that the liquid may be raised or lowered to and from the same. Thus the opposite ends of the fountain are provided with a stud 6, that enters a slot 7 in a side flange projecting from the plate 11, and is engaged by one end of a link 8, the opposite end of which is pivoted to the side of the plate. The fountain may be held in any position to which it may be adjusted by means of a spring-seated dog 9, mounted at the end of the link that engages with the teeth of a rack on the side of the flange. Other modes of adjustably mounting the fountain with respect to the end of the felt will occur to skilled workmen, and therefore need not be further shown.

It has been found in practice in the use of liquid-feeders that the ink from the freshly-printed sheet will readily absorb, without detriment to the sheet, more or less of the liquid applied to the surface of the impression-cylinder, but at the blank or white spaces between the print and formed by the margins the liquid will not be absorbed, and hence unless the liquid is applied to the surface of the cylinder with great regularity and evenness it will result in said white or blank spaces becoming discolored or stained by the liquid. As it is exceedingly difficult to get an absolute and nice adjustment of the liquid-feeder, so that the offset will be effectively prevented, and at the same time not too much liquid be left upon the cylinder, there is provided means by which this surplus or accumulation of liquid will be automatically absorbed. These means consist of a counter absorption-roll 40 or equivalent device extending transversely of the machine and adapted to bear in perfecting-presses against the surface of the second impression-cylinder, or, in other words, to bear against the same cylinder to which the liquid is applied by the liquid-feeder or offsetting mechanism. This absorption-roll is preferably located in this type of press between the two impression-cylinders and sufficiently above the plane of impression as not to interfere with the movement of the usual form-bed. This absorption-roll is provided with a surface of plush or other analogous absorbent material,

and is mounted at the end of a pair of arms extending from and fast to a rock-shaft 41, which also extends transversely across the machine above the plane of impression, and is mounted in bearings in the frame-work. The absorption-roll is preferably continuously driven by any suitable means—as, for instance, from the driving-gear 106 through an intermediate 42, mounted on a stud projecting from the frame-work in gear with a similar intermediate mounted loosely upon the shaft 41, that in turn is in gear with a similar toothed wheel 43, fast to the absorption-roll shaft.

In order to cause the absorption-roll to move into contact with the surface of the cylinder in the absence of the sheet and out of contact therewith during the passage of the sheet there is provided means for effecting this result. Thus the absorption-roll may be caused to vibrate on the shaft 41 by means of a cam 44, mounted on a stud projecting from the box of the impression-cylinder shaft and borne upon by a roll mounted at the end of an arm 45, extending from and fast to said shaft. The cam receives motion from the toothed wheel 103, that meshes with a similar wheel 46, secured to the cam and mounted upon the same stud. The proportion of these toothed wheels is such that the cam will have been turned a complete revolution upon each two complete revolutions of the impression-cylinder, so that the roll will have been in contact with the surface of the impression-cylinder during substantially a complete single revolution of said cylinder in the absence of a sheet, and out of contact with said cylinder during the succeeding complete revolution of the cylinder and while the sheet is passing the absorption-roll. The roll of the arms 52 is held to duty by a spring-pressed rod 47 from and fast to the shaft 41 and the other end passing through a perforation in a stud 48, the end of the rod having a pair of jam-nuts 49, by which the inward motion of the absorption-roll 40 may be regulated. The spring 50, that surrounds the rod, is interposed between the stud 48 and a collar on the rod. The cam 44, controlling the position of the absorption-roll with respect to the surface of the impression-cylinder, it will be seen, is mounted to move vertically with the latter in its movements to and from the plane of impression (through the usual means, not shown) independent of the roll and the arm 45, the spring-pressed roll permitting the roll and arm to yield as the cam and cylinder moves, so that the roll is kept from touching the passing sheet then on the cylinder.

It is to be remarked in passing that the invention is not limited to the use of the type of press illustrated, as it has simply been taken as a convenient means of illustrating a practical application to a printing-press of the invention, and that so far as the improved absorption-roll, broadly considered, is concerned the means shown by which said roll

is driven, and by which it is moved into and out of contact with the impression-cylinder, may be varied considerably. So, too, it will be obvious that the means for regulating or wholly stopping the supply of liquid fed by the liquid-feeder may be applied to other forms of liquid-feeders or set-off mechanism embodying an absorbing medium, and that the liquid-feeder may be operated by means wholly different from that herein shown.

No claim is herein made to that part of the apparatus shown which illustrates two independent sources for the sheets leading to a common point on the impression-cylinder, as the same forms the subject-matter of an application filed by me May 8, 1890, Serial No. 351,052.

What I claim is—

1. The combination, with the impression-cylinder of a printing-press, of a liquid set-off feeder composed of an absorbing medium, a portion of which has surface communication with the surface of the impression-cylinder and another portion adapted to be immersed in a liquid and adjustable as to its extent of immersion or entire removal in or from the liquid, substantially as described.
2. The combination, with the impression-cylinder of a printing-press, of a set-off distributing-roller and a liquid-feeder, one portion of which has surface communication through said distributing-roller with the surface of said cylinder and another portion adapted to be immersed in a liquid and adjustable as to its extent of immersion or entire removal in or from the liquid, substantially as described.
3. The combination, with the impression-cylinder of a printing-press, of a set-off roller rotating in unison therewith, mechanism whereby said set-off roller is automatically moved into and out of contact with the surface of the impression-cylinder, and a liquid-feeder, one portion of which has surface communication with said set-off roller and another portion adapted to be immersed in a liquid and adjustable with respect to the surface of the liquid, substantially as described.
4. The combination, with the impression-cylinder of a printing-press, of a liquid-feeder of absorbent material, one portion of which has surface communication with the impression-cylinder and another portion adapted to be immersed in a liquid and adjustable as to its extent of immersion or removal in or from the liquid, and mechanism for moving the liquid-feeder to break said surface communication at intervals, substantially as described.
5. The combination, with the impression-cylinder of a printing-press, of a liquid-feeder of absorbent material, a plate or plates for supporting the same, a liquid-receptacle into which one portion of the absorbent material is adapted to extend, and a movable lifter for adjusting said portion of the absorbent material with respect to the surface of the liquid, substantially as described.

6. The combination, with the impression-cylinder of a printing-press, of a liquid-feeder of absorbent material, a plate or plates supporting said material, a liquid-reservoir supported by said plate and into which one portion of the absorbent material is adapted to extend, a rock-shaft, and a plate extending therefrom in position to vary the immersion of said portion of the material in the liquid, substantially as described.

7. The combination, with the impression-cylinder of a printing-press, of a liquid-feeder of absorbent material, a plate or plates supporting said absorbent material, a liquid-reservoir, a rock-shaft, a plate extending therefrom within the reservoir, a ratchet and pawl for holding the rock-shaft and plate in position, and a handle for moving the rock-shaft, substantially as described.

8. The combination, with the impression-cylinder of a printing-press, of a liquid-feeder adapted to apply liquid to the surface of the cylinder and a counter absorbing-roll adapted to remove the surplus or accumulation of liquid therefrom, substantially as described.

9. The combination, with the impression-cylinder of a printing-press, of a liquid-feeder adapted to apply liquid to the surface of the cylinder, a counterabsorption-roll, and means

for moving said roll into and from contact with the said cylinder, substantially as described.

10. The combination, with the impression-cylinder of a printing-press, of a liquid-feeder adapted to apply liquid to the surface of the cylinder, a driven counterabsorption-roll, and means for moving said roll into and from contact with the said cylinder, substantially as described.

11. The combination, with the impression-cylinder of a printing-press, of a liquid-feeder adapted to apply liquid to the surface of the cylinder and a counter absorption-roll mounted to yield with respect to the surface of the cylinder, substantially as described.

12. The combination, with the impression-cylinder of a printing-press, of a liquid-feeder adapted to apply the liquid to the surface of the cylinder, a counter absorption-roll, a cam, and connections for controlling the contact of said roll with the surface of the impression-cylinder, substantially as described.

In testimony whereof I have signed my name in the presence of two witnesses.

JOHN BROOKS.

Witnesses:

GEO. H. GRAHAM,  
WALTER L. HETFIELD.