



US012135787B2

(12) **United States Patent**
McGarry et al.

(10) **Patent No.:** **US 12,135,787 B2**

(45) **Date of Patent:** ***Nov. 5, 2024**

(54) **DETECTION OF INDICATORS OF ATTACK**

USPC 726/1
See application file for complete search history.

(71) Applicant: **DELL PRODUCTS L.P.**, Round Rock, TX (US)

(56) **References Cited**

(72) Inventors: **Marc N. McGarry**, Murphy, TX (US);
Nizar A. Basan, Garland, TX (US);
Bradley C. Rood, Grapevine, TX (US);
Andy A. Yiu, Austin, TX (US)

U.S. PATENT DOCUMENTS

(73) Assignee: **Dell Products L.P.**, Round Rock, TX (US)

8,811,619	B2	8/2014	Khatri et al.
9,336,385	B1 *	5/2016	Spencer G06F 21/564
9,846,584	B1 *	12/2017	Khoruzhenko G06F 21/57
10,333,965	B2 *	6/2019	Gathala H04W 12/128
10,708,290	B2	7/2020	Steelman et al.
10,803,176	B2 *	10/2020	Villatel G06F 21/575
10,855,619	B1	12/2020	Andrews et al.
11,436,324	B2 *	9/2022	Shivanna H04L 9/3247
2007/0162733	A1	7/2007	Dennis et al.

(*) Notice: Subject to any disclaimer, the term of this patent is extended or adjusted under 35 U.S.C. 154(b) by 0 days.

(Continued)

This patent is subject to a terminal disclaimer.

FOREIGN PATENT DOCUMENTS

(21) Appl. No.: **17/896,622**

CN	111310178	*	6/2020	G06F 21/577
CN	114780960	A	* 7/2022	G06F 18/22

(22) Filed: **Aug. 26, 2022**

Primary Examiner — Josnel Jeudy

(74) Attorney, Agent, or Firm — Larson Newman, LLP

(65) **Prior Publication Data**

US 2022/0414220 A1 Dec. 29, 2022

(57) **ABSTRACT**

Related U.S. Application Data

(63) Continuation of application No. 17/193,152, filed on Mar. 5, 2021, now Pat. No. 11,507,661.

An information handling system includes a basic input/output system (BIOS), a memory, and a processor. The processor scans a current state of each BIOS attribute in the BIOS, and stores one or more changed attributes in a secure event log in the memory. The processor converts each changed attribute into a different threat event including a first changed attribute into a first threat event. The processor provides a list of threat events to multiple threat chains, each of which determine whether the threat events match threat criteria in a threat chain policy. In response to the threat event matching a threat criterion in the threat chain policy, the threat chain provides a threat state change to the processor, which in turn provides new threat state changes to a threat state change consumer.

(51) **Int. Cl.**
G06F 21/00 (2013.01)
G06F 21/56 (2013.01)
G06F 21/57 (2013.01)

(52) **U.S. Cl.**
CPC **G06F 21/566** (2013.01); **G06F 21/572** (2013.01); **G06F 2221/034** (2013.01)

(58) **Field of Classification Search**
CPC . G06F 2221/034; G06F 21/572; G06F 21/566

20 Claims, 4 Drawing Sheets

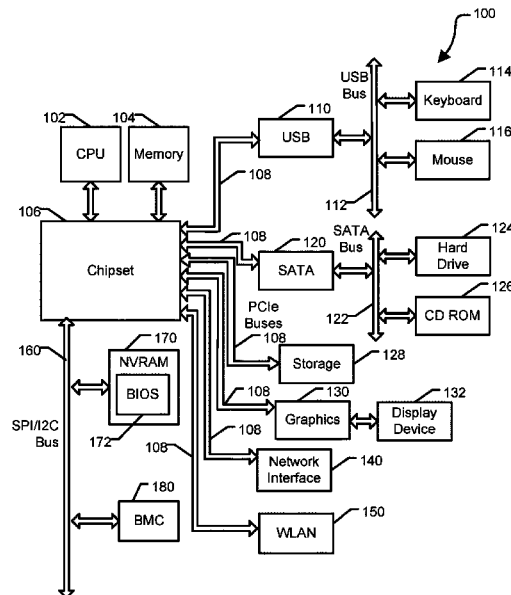

(56)

References Cited

U.S. PATENT DOCUMENTS

2014/0304520	A1	10/2014	Bobzin et al.	
2017/0243008	A1*	8/2017	Cornell	G06F 21/554
2019/0012465	A1	1/2019	Kim et al.	
2020/0364342	A1	11/2020	Martinez et al.	
2020/0372156	A1	11/2020	Sayyed et al.	
2021/0240567	A1	8/2021	Hsu et al.	

* cited by examiner

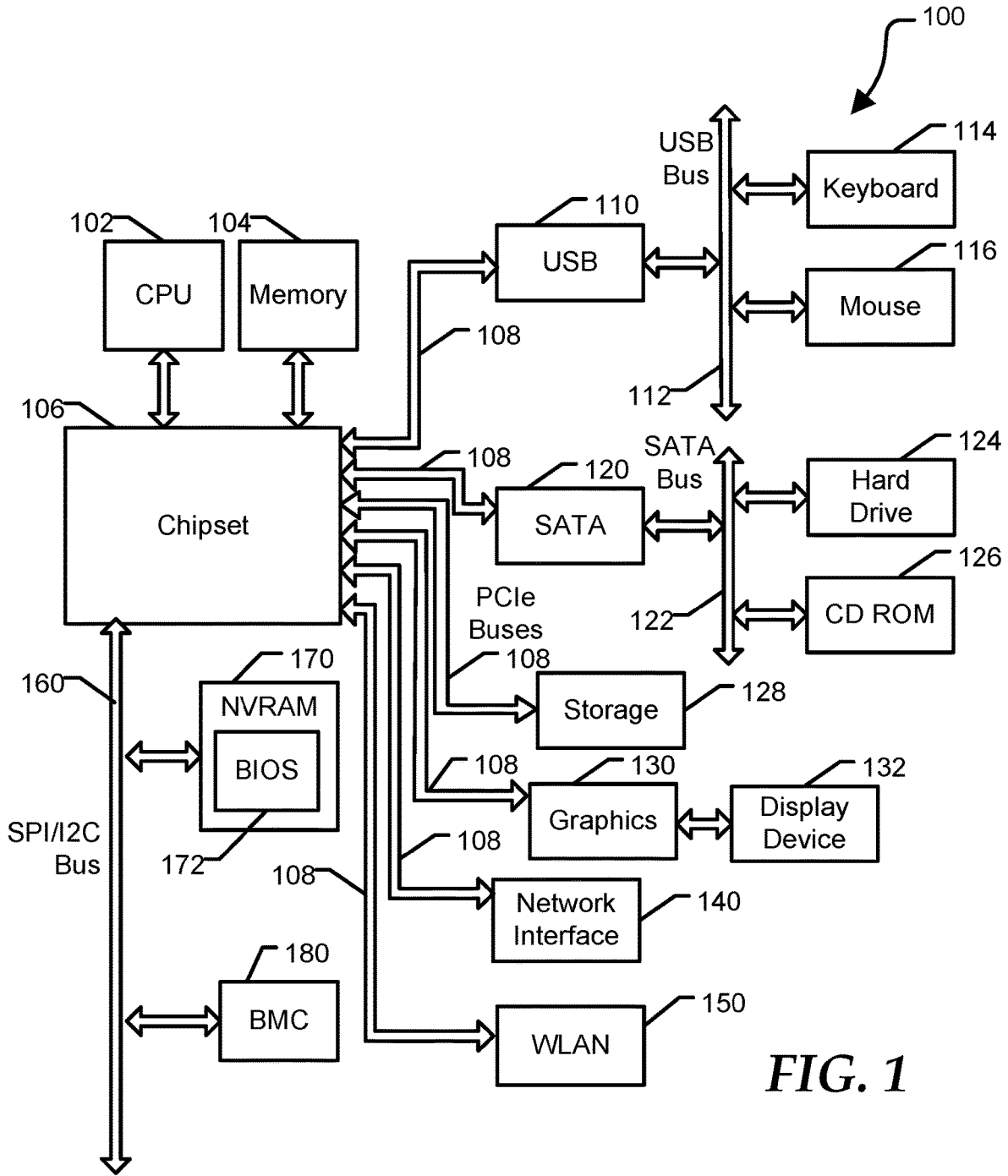

FIG. 1

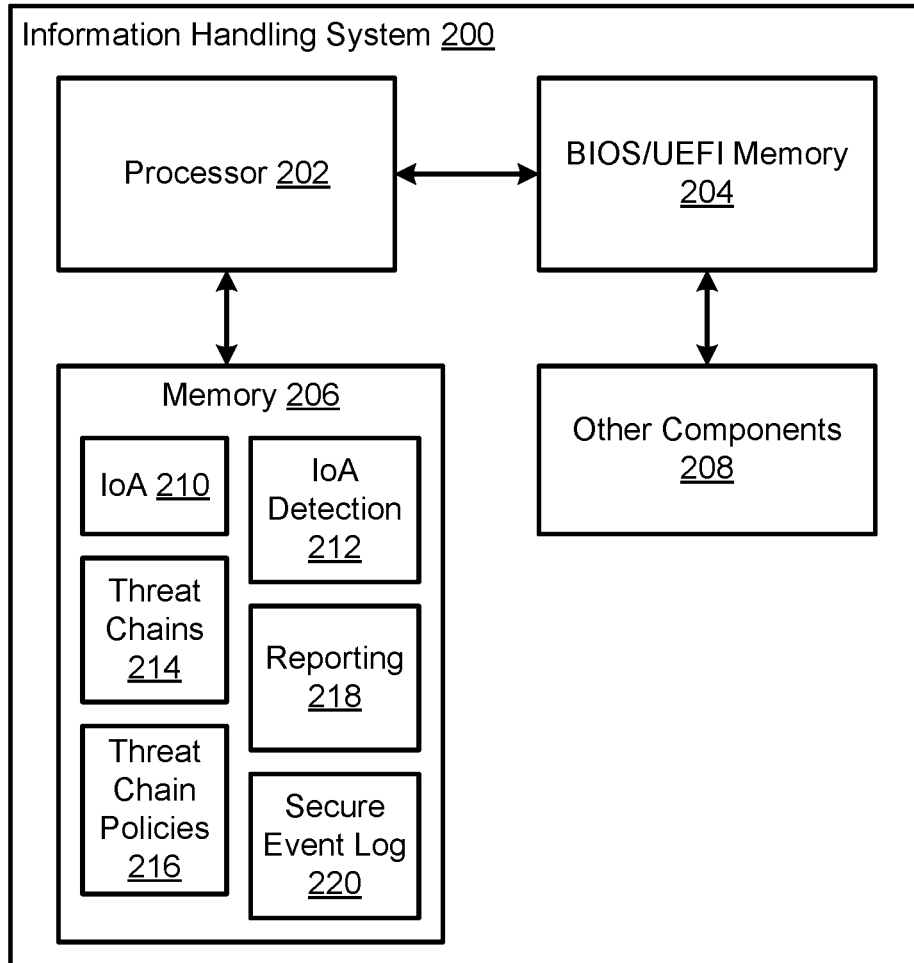

FIG. 2

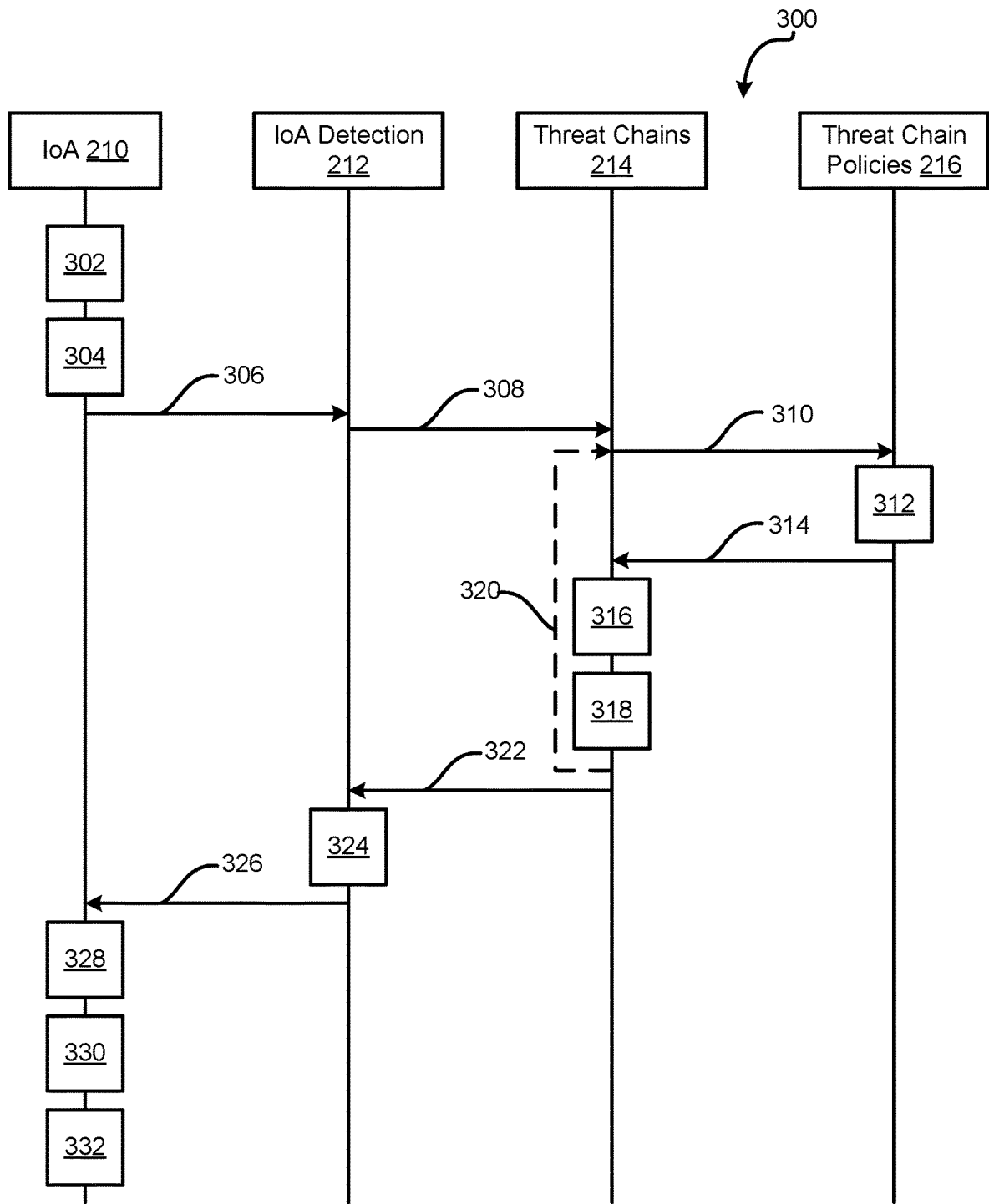

FIG. 3

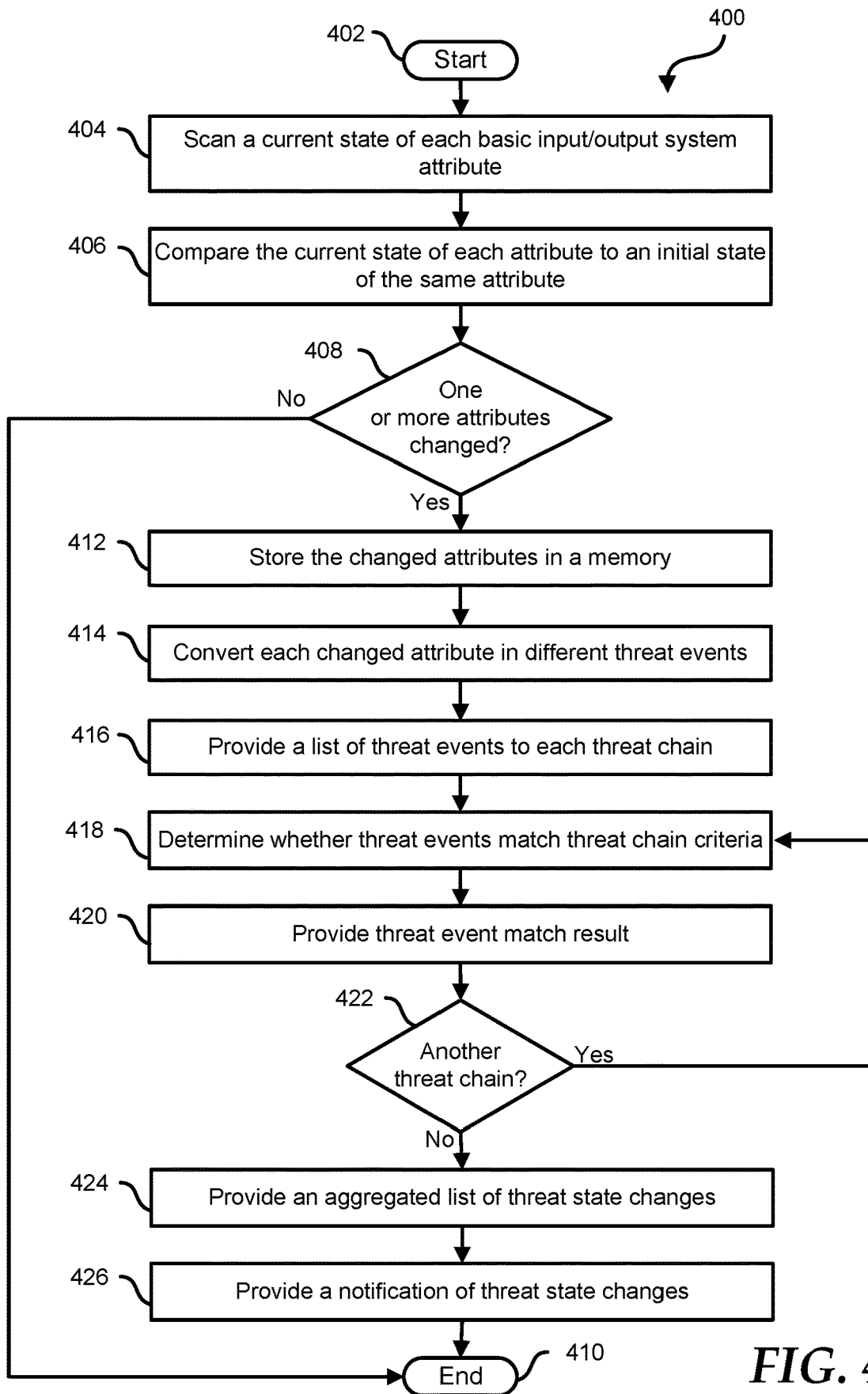

FIG. 4

DETECTION OF INDICATORS OF ATTACKCROSS-REFERENCE TO RELATED
APPLICATION

This application is a Continuation of U.S. patent application Ser. No. 17/193,152 entitled "DETECTION OF INDICATORS OF ATTACK," filed Mar. 5, 2021, the disclosure of which is hereby expressly incorporated by reference in its entirety.

FIELD OF THE DISCLOSURE

The present disclosure generally relates to information handling systems, and more particularly relates to detection of indicators of attack.

BACKGROUND

As the value and use of information continues to increase, individuals and businesses seek additional ways to process and store information. One option is an information handling system. An information handling system generally processes, compiles, stores, or communicates information or data for business, personal, or other purposes. Technology and information handling needs and requirements can vary between different applications. Thus, information handling systems can also vary regarding what information is handled, how the information is handled, how much information is processed, stored, or communicated, and how quickly and efficiently the information can be processed, stored, or communicated. The variations in information handling systems allow information handling systems to be general or configured for a specific user or specific use such as financial transaction processing, airline reservations, enterprise data storage, or global communications. In addition, information handling systems can include a variety of hardware and software resources that can be configured to process, store, and communicate information and can include one or more computer systems, graphics interface systems, data storage systems, networking systems, and mobile communication systems. Information handling systems can also implement various virtualized architectures. Data and voice communications among information handling systems may be via networks that are wired, wireless, or some combination.

SUMMARY

An information handling system includes a basic input/output system (BIOS), a memory, and a processor. The BIOS includes multiple BIOS attributes associated with the information handling system. The memory stores a secure event log associated with the attributes in the BIOS. The processor may scan a current state of each of the BIOS attributes, and store one or more changed attributes in the secure event log including a first changed attribute. The processor may convert each changed attribute into a different threat event including the first changed attribute into a first threat event. The processor may provide a list of threat events including the first event to multiple threat chains, each of which may determine whether the first threat event matches threat criteria in a threat chain policy. In response to the first threat event matching a threat criterion in the threat chain policy, the threat chains may provide a threat

state change to the processor, which in turn may provide new threat state changes to a threat state change consumer.

BRIEF DESCRIPTION OF THE DRAWINGS

It will be appreciated that for simplicity and clarity of illustration, elements illustrated in the Figures are not necessarily drawn to scale. For example, the dimensions of some elements may be exaggerated relative to other elements. Embodiments incorporating teachings of the present disclosure are shown and described with respect to the drawings herein, in which:

FIG. 1 is a block diagram of a general information handling system according to at least one embodiment of the present disclosure;

FIG. 2 is a block diagram of a portion of an information handling system according to at least one embodiment of the disclosure;

FIG. 3 is a diagram of operations performed within a processor according to at least one embodiment of the disclosure; and

FIG. 4 is a flow diagram of a method for detecting and reporting indicators of attack in an information handling system according to at least one embodiment of the present disclosure.

The use of the same reference symbols in different drawings indicates similar or identical items.

DETAILED DESCRIPTION OF THE DRAWINGS

The following description in combination with the Figures is provided to assist in understanding the teachings disclosed herein. The description is focused on specific implementations and embodiments of the teachings, and is provided to assist in describing the teachings. This focus should not be interpreted as a limitation on the scope or applicability of the teachings.

FIG. 1 illustrates a general information handling system **100**. For purposes of this disclosure, an information handling system may include any instrumentality or aggregate of instrumentalities operable to compute, classify, process, transmit, receive, retrieve, originate, switch, store, display, manifest, detect, record, reproduce, handle, or utilize any form of information, intelligence, or data for business, scientific, control, entertainment, or other purposes. For example, an information handling system may be a personal computer, a PDA, a consumer electronic device, a network server or storage device, a switch router or other network communication device, or any other suitable device and may vary in size, shape, performance, functionality, and price. The information handling system may include memory, one or more processing resources such as a central processing unit (CPU) or hardware or software control logic. Additional components of the information handling system may include one or more storage devices, one or more communications ports for communicating with external devices as well as various other I/O devices, such as a keyboard, a mouse, and a video display. The information handling system may also include one or more busses operable to transmit communications between the various hardware components.

Information handling system **100** including a processor **102**, a memory **104**, a chipset **106**, one or more PCIe buses **108**, a universal serial bus (USB) controller **110**, a USB bus **112**, a keyboard device controller **114**, a mouse device controller **116**, a configuration a SATA bus controller **120**, a SATA bus **122**, a hard drive device controller **124**, a compact disk read only memory (CD ROM) device controller **126**, a

storage **128**, a graphics device controller **130**, a network interface controller (NIC) **140**, a wireless local area network (WLAN) or wireless wide area network (WWAN) controller **150**, a serial peripheral interface (SPI) bus **160**, a NVRAM **170** for storing BIOS **172**, and a baseboard management controller (BMC) **180**. In an example, chipset **106** may be directly connected to an individual end point via a PCIe root port within the chipset and a point-to-point topology as shown in FIG. 1. BMC **180** can be referred to as a service processor or embedded controller (EC). Capabilities and functions provided by BMC **180** can vary considerably based on the type of information handling system. For example, the term baseboard management system is often used to describe an embedded processor included at a server, while an embedded controller is more likely to be found in a consumer-level device. As disclosed herein, BMC **180** represents a processing device different from CPU **102**, which provides various management functions for information handling system **100**. For example, an embedded controller may be responsible for power management, cooling management, and the like. An embedded controller included at a data storage system can be referred to as a storage enclosure processor.

System **100** can include additional processors that are configured to provide localized or specific control functions, such as a battery management controller. Bus **160** can include one or more busses, including a SPI bus, an I2C bus, a system management bus (SMBUS), a power management bus (PMBUS), and the like. BMC **180** can be configured to provide out-of-band access to devices at information handling system **100**. As used herein, out-of-band access herein refers to operations performed prior to execution of BIOS **172** by processor **102** to initialize operation of system **100**.

BIOS **172** can be referred to as a firmware image, and the term BIOS is herein used interchangeably with the term firmware image, or simply firmware. BIOS **172** includes instructions executable by CPU **102** to initialize and test the hardware components of system **100**, and to load a boot loader or an operating system (OS) from a mass storage device. BIOS **172** additionally provides an abstraction layer for the hardware, such as a consistent way for application programs and operating systems to interact with the keyboard, display, and other input/output devices. When power is first applied to information handling system **100**, the system begins a sequence of initialization procedures. During the initialization sequence, also referred to as a boot sequence, components of system **100** are configured and enabled for operation, and device drivers can be installed. Device drivers provide an interface through which other components of the system **100** can communicate with a corresponding device.

Information handling system **100** can include additional components and additional busses, not shown for clarity. For example, system **100** can include multiple processor cores, audio devices, and the like. While a particular arrangement of bus technologies and interconnections is illustrated for the purpose of example, one of skill will appreciate that the techniques disclosed herein are applicable to other system architectures. System **100** can include multiple CPUs and redundant bus controllers. One or more components can be integrated together. For example, portions of chipset **106** can be integrated within CPU **102**. Additional components of information handling system **100** can include one or more storage devices that can store machine-executable code, one or more communications ports for communicating with external devices, and various input and output (I/O) devices, such as a keyboard, a mouse, and a video display. An

example of information handling system **100** includes a multi-tenant chassis system where groups of tenants (users) share a common chassis, and each of the tenants has a unique set of resources assigned to them. The resources can include blade servers of the chassis, input/output (I/O) modules, Peripheral Component Interconnect-Express (PCIe) cards, storage controllers, and the like.

In an example, information handling system **100** may include any suitable device including, but not limited to, information handling system **200** of FIG. 2. Information handling system **100** can include a set of instructions that can be executed to cause the information handling system to perform any one or more of the methods or computer based functions disclosed herein. The information handling system **100** may operate as a standalone device or may be connected to other computer systems or peripheral devices, such as by a network.

In a networked deployment, the information handling system **100** may operate in the capacity of a server or as a client user computer in a server-client user network environment, or as a peer computer system in a peer-to-peer (or distributed) network environment. The information handling system **100** can also be implemented as or incorporated into various devices, such as a personal computer (PC), a tablet PC, a set-top box (STB), a personal digital assistant (PDA), a mobile device, a palmtop computer, a laptop computer, a desktop computer, a communications device, a wireless telephone, a land-line telephone, a control system, a camera, a scanner, a facsimile machine, a printer, a pager, a personal trusted device, a web appliance, a network router, switch or bridge, or any other machine capable of executing a set of instructions (sequential or otherwise) that specify actions to be taken by that machine. In a particular embodiment, the computer system **100** can be implemented using electronic devices that provide voice, video, or data communication. Further, while a single information handling system **100** is illustrated, the term "system" shall also be taken to include any collection of systems or sub-systems that individually or jointly execute a set, or multiple sets, of instructions to perform one or more computer functions.

FIG. 2 illustrates a portion of an information handling system **200** according to at least one embodiment of the disclosure. Information handling system **200** includes a processor **202**, a basic input/output system (BIOS)/unified extensible firmware interface (UEFI) (BIOS/UEFI) memory **204**, another memory **206**, and other components **208**. In an example, processor **202** may access BIOS/UEFI memory **204** to scan BIOS attributes stored within the BIOS/UEFI memory as will be discussed herein. Processor **202** may access memory **206** to perform one or more suitable operations including, but not limited to, store and retrieve data, and execute one or more applications. In certain examples, other components **208** may include any additional suitable components of information handling system **200** without varying from the scope of this disclosure.

Memory **206** may store data accessible by processor **202**, and may also store any suitable modules and applications executable by the processor. For example, memory **206** includes indicator of attacks (IoAs) module **210**, an IoA detection module **212**, multiple threat chains **214**, multiple threat chain policies **216**, a reporting module **218**, and a secure event log **220**. In an example, IoAs module **210**, IoA detection module **212**, threat chains **214**, threat chain policies **216**, and reporting module **218** may be incorporated within an OS of information handling system, and may be utilized by processor **202** to detect IoAs of the information handling system. In certain examples, IoAs module **210**, IoA

detection module **212**, threat chains **214**, threat chain policies **216**, and reporting module **218** may be components of BIOS/UEFI security agent configured to be executed by processor **202** to detect security threats by monitoring BIOS attributes changes made within BIOS/UEFI memory **204**.

In an example, each threat chain **214** may include one or more BIOS/UEFI attribute changes that, if detected, may be indicative of a threat or attack. Each BIOS/UEFI attribute change may be represented by a modification to the attribute in any suitable manner including, but not limited to, a binary flag, a selection from a list associated with the BIOS/UEFI configuration and stored in NVM **205**. Threat chain **214** may contain a threat chain policy **216**.

In an example, a threat chain policy **216** for a particular threat chain **214** may include a collection of BIOS attribute states that indicate a specific attack. For example, threat chain policy **214** may include a name, category, and list of one or more threat criteria for a particular attack. In certain examples, a threat chain policy **216** may include an initially empty history of matched threat criteria and an initially empty history of matched threat events. The history of matched threat criteria may be used to identify when the threat chain state is clear, partially matched, or fully matched as described below. In an example, the history of matched threat events may be saved to provide detailed reporting to the user of information handling system **200**.

In an example, reporting module **218** includes program instructions that, upon execution by processor **202**, may issue alerts, reports, and/or notifications to an administrator or the user about a detected BIOS/UEFI attack. In some cases, memory **206** may store, in secure event log **220**, historical values for BIOS attributes as they change over time. In other cases, memory **206** may retain, in secure event log **220**, only the currently set value for each BIOS attribute.

With respect to parameters collected concurrently with attribute changes, in some cases, a given BIOS attribute change may be associated with a “boot number” value that indicates, with respect to a preceding BIOS attribute change, whether the given change must be made in the same boot cycle, in a subsequent boot cycle, within a number of boot cycles, or after a number of boot cycles of information handling system **200**, in order for an attack to match a particular threat chain **214**. Additionally, or alternatively, a threat chain **214** may include a time interval between a first BIOS attribute change and a second BIOS attribute change, such that, in order to an attack to match that threat chain, the second change must be made within the time interval or after the time interval. Concurrently with the detection of BIOS/UEFI attribute value changes, a timestamp associated with each such change may also be stored and evaluated.

In certain examples, operations performed by IoA module **210**, IoA detection module **212**, threat chains **214**, threat chain policies **216**, and reporting module **218** may be executed in any suitable dedicated hardware device including, but not limited to, field-programmable gate array (FPGA) circuitry and an application-specific circuit (ASIC) without varying from the scope of this disclosure. Execution, by processor **202**, of one or more of IoA module **210**, IoA detection module **212**, threat chains **214**, threat chain policies **216**, and reporting module **218** will be described with respect to FIGS. **2** and **3** below.

FIG. **3** illustrates a set of operations **300** performed by a processor, such as processor **202** of FIG. **2**, according to at least one embodiment of the disclosure. In an example, processor **202**, or any other suitable device, may scan BIOS attributes within memory **204** to receive a current attribute state for each of the BIOS attributes. Processor **202** may

compare the current state of each BIOS attribute to an original state of the corresponding BIOS attribute to determine whether a state change has occurred. In an example, the original states of the BIOS attributes may be stored in any suitable memory including, but not limited to, secure event log **220** of memory **206** in FIG. **2**. Based on one or more BIOS attribute state changes, processor **202** may store BIOS events in secure event log **220**.

During operation **302**, IoA module **210** may read BIOS events from secure event log **220**. In an example, a BIOS event may any suitable data in any suitable format to indicate a BIOS attribute state change. For an example, the BIOS event may be true/false, on/off, a numerical value, or the like. During operation **304**, IoA module **210** may convert the BIOS events to threat events. In an example, IoA module **210** may convert the BIOS event in any suitable manner including, but not limited to, converting the BIOS event from its current format to a string format for the threat event. The string format for a particular threat event may include ‘attribute name, current value’. For example, a threat event may include ‘secure boot, off’, and this threat event may indicate that BIOS attribute ‘secure boot’ has changed from an ‘on’ state to an ‘off’ state.

During operation **306**, IoA module **210** may provide the threat events to IoA detection module **212**. In certain examples, IoA module **210** may determine whether the threat event has been previously detected and sent to IoA detection module **212**. If so, IoA module **210** may not notify IoA detection module of the threat event. During operation **308**, IoA detection module **212** may provide each threat event to each threat chain **214** of information handling system **200**. In an example, IoA detection module **212** may include a list of threat chains **214**, processing of the IoAs, or the like. In certain examples, a threat chain may include one or more BIOS attribute states to determine an attack is in progress or has occurred. For example, a threat chain may include a list of three BIOS attributes and all of the three BIOS attributes should have a threat event associated with the BIOS attribute to indicate an attack is in progress or has occurred.

During operation **310**, the threat events are provided to each of threat chain policies **216** for threat chains **214**. In certain examples, operations **312**, **314**, **316**, and **318** may be repeated for each threat chain **214** as illustrates by dashed arrow **320**. For example, each of the threat events is provide to a first threat chain policy **216** for a first threat chain **214**. During operation **312**, threat chain policy **216** may compare each threat event to the threat criteria for the associated threat chain **214**. Based on the comparison of all threat events to all threat criteria, threat policy **216** may return a threat event match results for each threat event during operation **314**. In an example, the threat event match results may indicate whether a particular threat event matches one of the criteria for threat chain **214**.

During operation **316**, the threat event match results may be stored. In certain examples, the threat event match results may be stored within any suitable memory including, but not limited to, memory **206**. In an example, a history, such as previous the threat event match results may be stored on a threat chain-by-threat chain basis. During operation **318**, a threat state change is generated for threat chain **214**. For example, a determination is made whether an attack associated with a particular threat chain **214** appears or clears. In an example, a current status of an attack may be compared with a previous status of the attack to determine whether the attack has appeared or has cleared. The generated threat state change may indicate not changed, partially changed, or fully

changed. The threat state change may also include a threat chain identifier and a category for a matching threat chain. The threat state change may further include any other suitable information about the threat event and threat chain including, but not limited to, a previous threat state of the threat chain, a current threat state of the threat change, a timestamp describing when the threat state change was created, and a threat event history of the threat chain after the threat event was processed. If additional threat chains **214** are present in the information handling system, the operations loop as indicated by arrow **320**.

During operation **322**, a list of threat state changes is provided to IoA detection module **212**. In an example, a single threat state change may be provided for each threat chain **214**. During operation **324**, IoA detection module **212** may aggregate the threat state changes from all threat chains **214**. During operation **326**, the aggregated list of threat state changes is provided to IoA module **210**. During operation **328**, IoA module **210** reads a list of existing threat state changes from secure event log **220**. During operation **330**, IoA module **210** removes pre-existing threat state changes from the aggregated list. In an example, IoA module **210** may compare the threat state changes in the aggregated list to the existing threat state changes and remove any matching threat state changes from the aggregated list.

During operation **332**, the threat state changes in the aggregated list are written to secure event log **220** and a user of the information handling system is notified of the threat state changes. In an example, the user may be notified in any suitable manner including, but not limited to, the threat state changes being written to a log and a message displayed on a console of the information handling system. In certain examples, the threat state changes may include any suitable data associated with the threat state change including, but not limited to, a timestamp indicating when the state change occurred. In an example, the user may also be notified about the timestamp associated with the threat state change.

FIG. 4 is a flow diagram of a method for detecting and reporting indicators of attack in an information handling system according to at least one embodiment of the present disclosure, starting at block **402**. It will be readily appreciated that not every method step set forth in this flow diagram is always necessary, and that certain steps of the methods may be combined, performed simultaneously, in a different order, or perhaps omitted, without varying from the scope of the disclosure. FIG. 4 may be employed in whole, or in part, by information handling system **100** depicted in FIG. 1, information handling system **200** in FIG. 2, or any other type of system, controller, device, module, processor, or any combination thereof, operable to employ all, or portions of, the method of FIG. 4.

At block **404**, a current state of each BIOS attribute in an information handling system is scanned. In an example, the BIOS attributes may be stored in any suitable memory including, but not limited to, a BIOS/UEFI memory. At block **406**, the current state of each attribute is compared to an initial state of the same attribute. At block **408**, a determination is made whether one or more attributes have been changed. If no attributes have been changed the flow ends at block **410**.

If one or more attributes have been changed, the changed attributes are stored in a memory as BIOS events at block **412**. At block **414**, each changed attribute or BIOS event is converted into a different threat event. In an example, the BIOS events may be converted into threat events in any suitable manner including, but not limited to, converting the

BIOS events from a current format to a string format for the threat events. The string format for a particular threat event may include 'attribute name, current value'.

At block **416**, a list of threat events is provided to each threat chain in an information handling system. At block **418**, a determination is made whether each threat event matches criteria of the threat chain. In an example, the criteria for a threat chain may be stored within a threat chain policy associated with the particular threat chain. At block **420**, threat event match results are provided based on whether the criteria of the threat chain have been matched. In an example, the threat event match results may be evaluated and determination may be made if the state of the current chain has changed. If the state of the current chain has changed, a threat state change is created describing the chain criteria that has been matched or unmatched along with the match indicator. In certain examples, the match indicator may be any suitable identifier for a level or degree of the match including, but not limited to, cleared, partially-matched, and fully-matched.

At block **422**, a determination is made whether another threat chain exists in the information handling system. If so, the flow continues as stated above at block **418**. Otherwise, an aggregated list of threat state changes is provided at block **424**. In an example, the aggregated list may include the threat state changes for every threat chain in the information handling system. At block **426**, a notification of threat state changes is provided to a user of the information handling system, and the flow ends at block **410**. In an example, the user may be notified in any suitable manner including, but not limited to, the threat state changes being written to a log and a message displayed on a console of the information handling system.

Referring back to FIG. 1, the information handling system **100** can include a disk drive unit and may include a computer-readable medium, not shown in FIG. 1, in which one or more sets of instructions, such as software, can be embedded. Further, the instructions may embody one or more of the methods or logic as described herein. In a particular embodiment, the instructions may reside completely, or at least partially, within system memory **104** or another memory included at system **100**, and/or within the processor **102** during execution by the information handling system **100**. The system memory **104** and the processor **102** also may include computer-readable media.

While the computer-readable medium is shown to be a single medium, the term "computer-readable medium" includes a single medium or multiple media, such as a centralized or distributed database, and/or associated caches and servers that store one or more sets of instructions. The term "computer-readable medium" shall also include any medium that is capable of storing, encoding, or carrying a set of instructions for execution by a processor or that cause a computer system to perform any one or more of the methods or operations disclosed herein.

In a particular non-limiting, exemplary embodiment, the computer-readable medium can include a solid-state memory such as a memory card or other package that houses one or more non-volatile read-only memories. Further, the computer-readable medium can be a random access memory or other volatile re-writable memory. Additionally, the computer-readable medium can include a magneto-optical or optical medium, such as a disk or tapes or other storage device to store information received via carrier wave signals such as a signal communicated over a transmission medium. Furthermore, a computer readable medium can store information received from distributed network resources such as

from a cloud-based environment. A digital file attachment to an e-mail or other self-contained information archive or set of archives may be considered a distribution medium that is equivalent to a tangible storage medium. Accordingly, the disclosure is considered to include any one or more of a computer-readable medium or a distribution medium and other equivalents and successor media, in which data or instructions may be stored.

When referred to as a “device,” a “module,” or the like, the embodiments described herein can be configured as hardware. For example, a portion of an information handling system device may be hardware such as, for example, an integrated circuit (such as an Application Specific Integrated Circuit (ASIC), a Field Programmable Gate Array (FPGA), a structured ASIC, or a device embedded on a larger chip), a card (such as a Peripheral Component Interface (PCI) card, a PCI-express card, a Personal Computer Memory Card International Association (PCMCIA) card, or other such expansion card), or a system (such as a motherboard, a system-on-a-chip (SoC), or a stand-alone device).

The device or module can include software, including firmware embedded at a processor or software capable of operating a relevant environment of the information handling system. The device or module can also include a combination of the foregoing examples of hardware or software. Note that an information handling system can include an integrated circuit or a board-level product having portions thereof that can also be any combination of hardware and software.

Devices, modules, resources, or programs that are in communication with one another need not be in continuous communication with each other, unless expressly specified otherwise. In addition, devices, modules, resources, or programs that are in communication with one another can communicate directly or indirectly through one or more intermediaries.

Although only a few exemplary embodiments have been described in detail herein, those skilled in the art will readily appreciate that many modifications are possible in the exemplary embodiments without materially departing from the novel teachings and advantages of the embodiments of the present disclosure. Accordingly, all such modifications are intended to be included within the scope of the embodiments of the present disclosure as defined in the following claims. In the claims, means-plus-function clauses are intended to cover the structures described herein as performing the recited function and not only structural equivalents, but also equivalent structures.

What is claimed is:

1. An information handling system comprising:

a basic input/output system (BIOS), the BIOS including a plurality of BIOS attributes associated with the information handling system; and

a processor to communicate with the BIOS, the processor to:

scan a current state of each of the BIOS attributes; store one or more changed BIOS attributes as one or more BIOS events;

collect a boot number value associated with one of the changed BIOS attributes, wherein the boot number value indicates a boot cycle during which a given BIOS change must be made;

convert the one or more changed BIOS events into a different threat event, wherein the changed BIOS events are converted from a first data format to a second data format of the different threat event;

determine whether a first threat event matches threat criteria in a threat chain policy, wherein the first threat event is associated with a first changed BIOS attribute of the BIOS attributes;

in response to the first threat event matching a threat criterion in the threat chain policy, provide a threat state change; and

provide new threat state changes to a threat state change consumer.

2. The information handling system of claim **1**, wherein the providing of the threat state change includes: the processor to return each threat event that matches a threat criterion in the threat chain policy, to store the matched threat events in a threat event history, and to generate the threat state change based on appearance or clearing of an attack of the information handling system.

3. The information handling system of claim **1**, wherein the processor further to return a single threat state change for each threat chain policy.

4. The information handling system of claim **1**, wherein the processor further to generate an aggregated list of threat state changes.

5. The information handling system of claim **4**, wherein the processor further to retrieve a list of existing threat state changes from a secure event log in a memory of the information handling system, and to remove pre-existing threat state changes from the aggregated list of threat state changes.

6. The information handling system of claim **1**, wherein a threat state for the threat chain indicates a full match when each threat criteria for a particular threat chain is matched.

7. The information handling system of claim **1**, wherein the first threat event includes an attribute name and a current value for the attribute.

8. The information handling system of claim **1**, wherein each of the threat chains corresponds to a different type of attack on the information handling system.

9. A method comprising:

scanning a current state of each of a plurality of basic input/output system (BIOS) attributes;

storing one or more changed BIOS attributes as one or more BIOS events;

collecting a boot number value associated with one of the changed BIOS attributes, wherein the boot number value indicates a boot cycle during which a given BIOS change must be made;

converting the one or more changed BIOS events into a different threat event, wherein the changed BIOS events are converted from a first data format to a second data format of the different threat event;

determining whether a first threat event matches threat criteria in a threat chain policy, wherein the first threat event is associated with a first changed BIOS attribute of the BIOS attributes;

in response to the first threat event matching a threat criterion in the threat chain policy, providing a threat state change; and

providing new threat state changes to a threat state change consumer.

10. The method of claim **9**, wherein the providing of the threat state change further comprises:

returning each threat event that matches a threat criterion in the threat chain policy;

storing the matched threat events in a threat event history; and

11

generating the threat state change based on appearance or clearing of an attack of the information handling system.

11. The method of claim 9, further comprising returning a single threat state change for each threat chain policy.

12. The method of claim 9, further comprising generating an aggregated list of threat state changes.

13. The method of claim 12, further comprising:
retrieving a list of existing threat state changes from a secure event log in a memory; and
removing pre-existing threat state changes from the aggregated list of threat state changes.

14. The method of claim 9, wherein a threat state for the threat chain indicates a full match when each threat criteria for a particular threat chain is matched.

15. The method of claim 9, wherein the first threat event includes an attribute name and a current value for the attribute.

16. The method of claim 9, wherein each of the threat chains corresponds to a different type of attack on the information handling system.

17. A method comprising:
scanning a current state of each of a plurality of basic input/output system (BIOS) attributes;
storing one or more changed BIOS attributes as one or more BIOS events;
collecting a boot number value associated with one of the one or more changed BIOS attributes, wherein the boot number value indicates a boot cycle during which a given BIOS change must be made;

12

converting the one or more changed BIOS events into a different threat event, wherein the changed BIOS events are converted from a first data format to a second data format of the different threat event;

determining whether a first threat event matches threat criteria in a threat chain policy, wherein the first threat event is associated with a first changed BIOS attribute of the BIOS attributes;

in response to the first threat event matches a threat criterion in the threat chain policy:

returning each threat event that matches a threat criterion in the threat chain policy;

storing the matched threat events in a threat event history; and

generating a threat state change based on appearance or clearing of an attack of the information handling system;

retrieving a list of existing threat state changes from the secure event log in the memory; and

removing pre-existing threat state changes from the aggregated list of threat state changes.

18. The method of claim 17, wherein a threat state for the threat chain indicates a full match when each threat criteria for a particular threat chain is matched.

19. The method of claim 17, wherein the first threat event includes an attribute name and a current value for the attribute.

20. The method of claim 17, wherein each of the threat chains corresponds to a different type of attack on the information handling system.

* * * * *