

No. 891,749.

PATENTED JUNE 23, 1908.

W. O. THOMPSON, DEC'D.
B. P. THOMPSON, ADMINISTRATRIX.

SAUSAGE STUFFER.

APPLICATION FILED JAN. 5, 1907.

Fig. 1.



Fig. 3. Fig. 4.

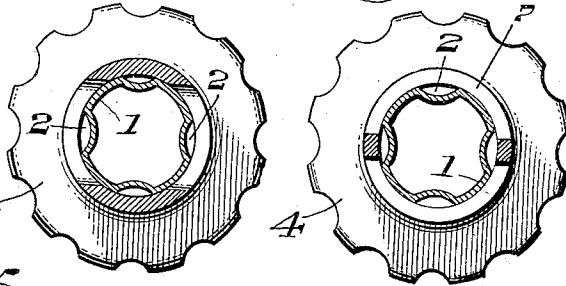

Fig. 2.

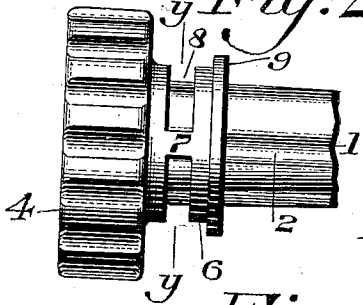

Fig. 5.

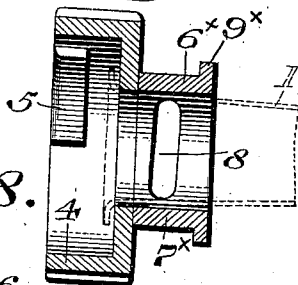

Fig. 6.

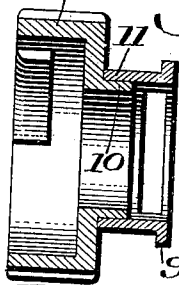

Fig. 8.

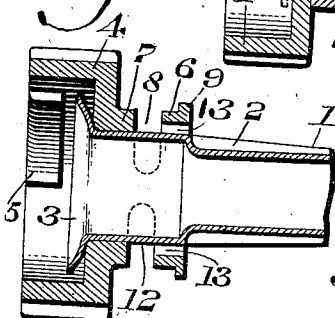
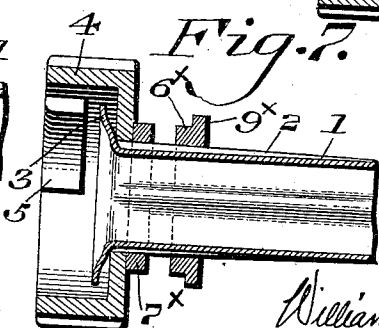

Fig. 7.



Witnesses
P. F. Nagle.
L. Douville.

Inventor
William O. Thompson,
By
Biederstein & Fairbanks,
Attorneys

UNITED STATES PATENT OFFICE.

WILLIAM O. THOMPSON, OF PHILADELPHIA, PENNSYLVANIA; BERTHA P. THOMPSON, ADMINISTRATRIX OF SAID WILLIAM O. THOMPSON, DECEASED, ASSIGNOR TO NATIONAL SPECIALTY MANUFACTURING COMPANY, OF PHILADELPHIA, PENNSYLVANIA.

SAUSAGE-STUFFER.

No. 891,749.

Specification of Letters Patent.

Patented June 23, 1908.

Application filed January 5, 1907. Serial No. 350,908.

To all whom it may concern:

Be it known that I, WILLIAM O. THOMPSON, a citizen of the United States, residing in the city and county of Philadelphia, State of Pennsylvania, have invented a new and useful Sausage-Stuffer, of which the following is a specification.

My invention relates to a new and useful nozzle and coupling used in connection with sausage stuffers and lard presses and consists in providing means for stiffening and strengthening the nozzle and for allowing air to escape from the casing of the sausage, as it is being stuffed.

It further consists in providing a ring so situated as to prevent the closing of the passages formed in the nozzle.

It further consists of other novel features of construction, all as will be hereinafter fully set forth.

Figure 1 represents a side elevation of a nozzle embodying my invention, showing the parts in position. Fig. 2 represents an elevation of a portion of the device showing a slightly different form of ring employed. Fig. 3 represents a sectional view on line $x-x$ Fig. 1. Fig. 4 represents a sectional view on line $y-y$ Fig. 2. Fig. 5 represents a sectional view of a coupling and ring, which are separate from each other, showing a portion of the nozzle in dotted lines. Fig. 6 represents a sectional view of a coupling and a ring which is detachably secured thereto. Fig. 7 represents a sectional view of a coupling and a portion of the nozzle and a ring which is separate from the coupling and which is adapted to frictionally engage with the nozzle. Fig. 8 represents a sectional view of a portion of the nozzle and coupling, the flange of which is provided with grooves or recesses on its inner face, communicating with the grooves in the face of the nozzle.

Similar numerals of reference indicate corresponding parts in the figures.

Referring to the drawings. I have found in practice that nozzles and couplings for sausage stuffers as at present formed, are objectionable, owing to the fact that the nozzles are easily bent and broken since the couplings bear upon only a small portion of the nozzles and bend the same by reason of the lateral movement which occurs and in

the present application I have shown a construction for overcoming this difficulty. In addition, it is necessary to prevent the sausage casing from closing the inner ends of the grooves formed in the nozzle and I have shown a device for accomplishing this purpose as well. I am aware that it is old to have a ring secured to the nozzle at a suitable point thereon, to prevent the casing from closing the ends of the said grooves but owing to the small size of these rings, since it is necessary that they pass the openings in the couplings, they often fail in their purpose.

I am enabled by my construction to form a ring which is of such a diameter as to overcome the objections.

In the drawings I have shown a construction for carrying out my invention but it will be evident that changes may be made therein which will come within the scope of my invention and I do not therefore desire to be limited in every instance to the exact construction herein shown and described.

1 designates a nozzle having a series of longitudinally extending grooves 2 formed in the face thereof, which extend a suitable distance therein, in the present instance, from the point near the flange 3 of the nozzle to a suitable point adjacent the outer end thereof, it being noted that the grooves are preferably deeper at the ends adjacent said flange and that they are preferably tapered.

4 designates a coupling which is adapted to be secured to the body of the stuffer or lard press in any suitable manner and in the present instance the coupling is provided with the lugs 5 which coact with suitable lugs on the body of the stuffer or lard press, in order that the said coupling can be quickly and easily clamped in position or removed therefrom.

In order to stiffen and strengthen the nozzle, I have provided the coupling with a flange 7, the inner diameter of which is such as to closely engage the walls of the nozzle adjacent the coupling and upon the flange I provide a ring 6 which has a lug 9 extending therefrom, in order to form a ring of considerable diameter, it being noted that the ring 6 and lug 9 will be situated a suitable distance from the coupling 4 and as the flange and

ring both closely engage with the walls of the nozzle, they serve both to strengthen the nozzle and at the same time prevent the casing of the sausage from closing the grooves 2, which will thus always remain open.

It will be noted that by reason of the extent of the flange and ring that the nozzle will be firmly held a considerable distance from the flange and that no point is subjected to the lateral strains, as at present occurs in devices now in use.

In the flange 7 or between it and the ring 6, I provide spaces 8 which may be of any extent and which are formed in the constructions seen in Figs. 1 and 2 over the ends of the grooves 2, so that as before stated the latter will always be open.

In the construction seen in Figs. 1 and 2, the flange 7 and ring 6 form part of or are connected with the coupling 4 but in the construction shown in Fig. 5, I have formed the flange and ring separate from the coupling 4, the flange 7^x in this figure abutting against the end of the coupling when the parts are in position, holding the ring 6^x and flange 9^x at a proper distance therefrom.

In Fig. 6, I have shown the coupling provided with a boss 10 which is removably engaged by the extension 11 carrying the flange 9, as before shown, in order that the parts will be situated a proper distance on the nozzle.

In the construction shown in Fig. 7, I have shown the flange 7^x and ring 6^x as separate and distinct from the coupling 4 and I so construct the said flange and ring that they will closely engage the exterior of the nozzle 1 at a suitable point, so that frictional engagement is made between the same and said nozzle, in order that said ring may be removably held upon the nozzle 1 and prevented from approaching too closely the coupling 4, it being noted that in all the constructions heretofore described the ring 6 is so situated upon the nozzle 1 as to be over the grooves 2 in said nozzle.

In the construction shown in Fig. 8, I have shown the nozzle 1 as provided with grooves 2 which are started some distance from the flange 3 and between which and the said grooves, as at 12, the nozzle is preferably made tapered and cylindrical and this portion of the nozzle is closely engaged by the flange 7, as heretofore, but the ring 6 and lug 9 do not project over the grooves 2 in the nozzle, I provide grooves 13 in the inner face of the ring 6 through which the air from the casing of the sausage, when being stuffed, can pass. By this means it will be noted that I am enabled to stiffen and strengthen the nozzle and I use the ring to prevent the casing from closing the end of the grooves

in the nozzle and the ring is not situated as before stated, over said grooves in the nozzle.

Having thus described my invention, what I claim as new and desire to secure by Letters Patent, is:—

1. In a device of the character described, a nozzle having a groove therein, and a coupling adapted to be secured to the sausage stuffer, having a flange extending forwardly on said coupling and closely engaging throughout its length, the outer wall of the nozzle for stiffening the same, and having a ring between which and the flange is provided an opening.

2. In a device of the character described, a nozzle having a groove therein, and a coupling adapted to be secured to the sausage stuffer having a flange extending forwardly on said coupling engaging throughout its length the outer wall of the nozzle for stiffening the same and having a ring connected with said flange and between which is provided an opening and said ring having an outwardly extending lug.

3. In a device of the character described, a nozzle having a groove therein and provided with a flange, said nozzle being tubular between said flange and the end of said groove, and a coupling adapted to be suitably connected with a sausage stuffer and engaging said nozzle and having a flange extending forwardly on said coupling closely engaging throughout its length, said tubular portion of said nozzle and provided with a groove on its inner face.

4. In a device of the character described, a nozzle having a groove therein, a coupling adapted to be suitably secured to a sausage stuffer and engaging said nozzle, said coupling having a flange closely engaging said nozzle and provided with an opening, the outer end of which is situated at the end of the groove but not overlapping same and said flange being provided with a groove formed in the inner face thereof and communicating with said opening.

5. In a device of the character described, a nozzle having a groove therein, a coupling adapted to be suitably connected with a sausage stuffer and engaging said nozzle, said coupling having a flange, a ring on said coupling, an opening therebetween, the outer end of the ring being situated adjacent the end of the groove in said nozzle but not overlapping the same and said ring having a groove in the inner face thereof leading from the front face thereof to said opening.

WILLIAM O. THOMPSON.

Witnesses:

JOHN WIEDERSHEIM,
C. D. McVAY.