



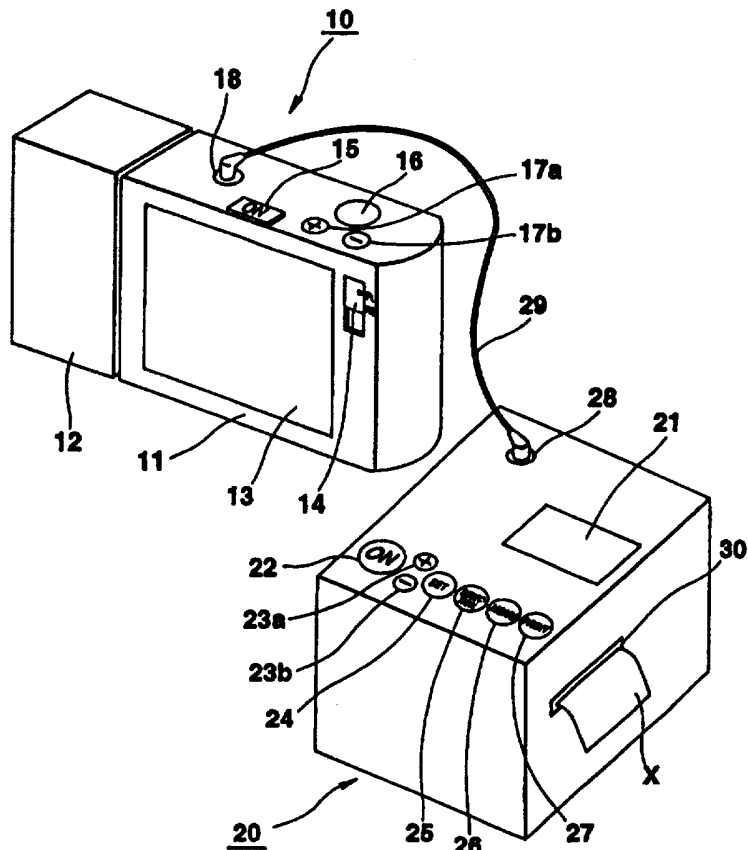
INTERNATIONAL APPLICATION PUBLISHED UNDER THE PATENT COOPERATION TREATY (PCT)

<p>(51) International Patent Classification <sup>6</sup> : <b>H04N 1/00</b></p>	<p><b>A1</b></p>	<p>(11) International Publication Number: <b>WO 97/50243</b> (43) International Publication Date: 31 December 1997 (31.12.97)</p>
<p>(21) International Application Number: PCT/JP97/02148 (22) International Filing Date: 23 June 1997 (23.06.97)</p> <p>(30) Priority Data: 8/164487 25 June 1996 (25.06.96) JP 8/260022 30 September 1996 (30.09.96) JP 8/260023 30 September 1996 (30.09.96) JP 8/280229 30 September 1996 (30.09.96) JP</p> <p>(71) Applicant (for all designated States except US): CASIO COMPUTER CO., LTD. [JP/JP]; 6-1, Nishi-Shinjuku 2-chome, Shinjuku-ku, Tokyo 163-02 (JP).</p> <p>(72) Inventors; and (75) Inventors/Applicants (for US only): SASAKI, Koh [JP/JP]; 3-1-168, Somechi, Chofu-shi, Tokyo 182 (JP). ISHIKAWA, Tomohisa [JP/JP]; 23-9, Higashi-Tamachi, Kawagoe-shi, Saitama 350 (JP).</p> <p>(74) Agent: KOMIZO, Satoshi; Kanda-Sakata Building, 6th floor, 2-5-1, Kandanishiki-cho, Chiyoda-ku, Tokyo 101 (JP).</p>		<p>(81) Designated States: AU, CA, CN, KR, NO, PL, SG, US, European patent (AT, BE, CH, DE, ES, FI, FR, GB, IT, NL, SE).</p> <p>Published With international search report.</p>

(54) Title: PRINTING APPARATUS AND PRINTING SYSTEM

(57) Abstract

When an "ON" key (22) of a printer (20) is operated in the state wherein a digital camera (10) and the printer (20) can communicate with each other, menu data and a menu display command signal are transferred to the digital camera (10), and a print menu is displayed on a liquid crystal display section (13). When a "SET" key (24) is operated, an image readout command signal is transferred to the digital camera (10), and stored image data representing a recorded image is displayed on the liquid crystal display section (13). When a "+" key (23a) or a "-" key (23b) is depressed under the condition wherein the image is being displayed on the liquid crystal display section (13), an image switching command signal is transferred to the digital camera (10), and the image which is being displayed is switched to another recorded image. When a "PRINT" key (27) is operated under the condition wherein the desired image is being displayed on the liquid crystal display section (13), a print command signal is sent from the printer (20) to the digital camera (10), and image data corresponding to the image which is being displayed on the liquid crystal display section (13) is transferred to the digital camera (10) or the printer (20). The printer (20) prints the image corresponding to the transferred image data, in accordance with a print mode determined.



**FOR THE PURPOSES OF INFORMATION ONLY**

Codes used to identify States party to the PCT on the front pages of pamphlets publishing international applications under the PCT.

AL	Albania	ES	Spain	LS	Lesotho	SI	Slovenia
AM	Armenia	FI	Finland	LT	Lithuania	SK	Slovakia
AT	Austria	FR	France	LU	Luxembourg	SN	Senegal
AU	Australia	GA	Gabon	LV	Latvia	SZ	Swaziland
AZ	Azerbaijan	GB	United Kingdom	MC	Monaco	TD	Chad
BA	Bosnia and Herzegovina	GE	Georgia	MD	Republic of Moldova	TG	Togo
BB	Barbados	GH	Ghana	MG	Madagascar	TJ	Tajikistan
BE	Belgium	GN	Guinea	MK	The former Yugoslav Republic of Macedonia	TM	Turkmenistan
BF	Burkina Faso	GR	Greece			TR	Turkey
BG	Bulgaria	HU	Hungary	ML	Mali	TT	Trinidad and Tobago
BJ	Benin	IE	Ireland	MN	Mongolia	UA	Ukraine
BR	Brazil	IL	Israel	MR	Mauritania	UG	Uganda
BY	Belarus	IS	Iceland	MW	Malawi	US	United States of America
CA	Canada	IT	Italy	MX	Mexico	UZ	Uzbekistan
CF	Central African Republic	JP	Japan	NE	Niger	VN	Viet Nam
CG	Congo	KE	Kenya	NL	Netherlands	YU	Yugoslavia
CH	Switzerland	KG	Kyrgyzstan	NO	Norway	ZW	Zimbabwe
CI	Côte d'Ivoire	KP	Democratic People's Republic of Korea	NZ	New Zealand		
CM	Cameroon			PL	Poland		
CN	China	KR	Republic of Korea	PT	Portugal		
CU	Cuba	KZ	Kazakistan	RO	Romania		
CZ	Czech Republic	LC	Saint Lucia	RU	Russian Federation		
DE	Germany	LI	Liechtenstein	SD	Sudan		
DK	Denmark	LK	Sri Lanka	SE	Sweden		
EE	Estonia	LR	Liberia	SG	Singapore		

## DESCRIPTION

### PRINTING APPARATUS AND PRINTING SYSTEM

#### Technical Field

The present invention relates to a printing apparatus, which is to be  
5 connected to an image recording apparatus in which a still image is recorded  
and reproduced as digital image data, for receiving the image from the image  
recording apparatus and printing the received image, and also relates to a  
printing system.

#### Background Art

10 Printers are conventionally used as terminals for printing data output from  
host equipment such as large-sized computers, office computers and personal  
computers, etc.

Of late, multimedia has been promoted in association with personal  
computers and various electronic apparatuses. In particular, personal  
15 computers not only can utilize conventional database, word processors and  
application software such as that for calculations on tables, but also can easily  
reproduce still pictures like photographs, television pictures and motion pictures  
such as those on karaoke and realize a communication function through the  
Internet, etc. by increasing the memory capacity and incorporating JPEG or  
20 MPEG circuits or modems in the personal computers.

In recent years, electronic still cameras (digital cameras) wherein the  
photographs taken thereby can be processed directly with personal computers  
have been being marketed widely in place of ordinary cameras using color  
films.

25 Such digital cameras comprise, for example, an image pick-up lens, a  
CCD (Charge Coupled Device) and a liquid crystal display serving as a  
viewfinder when recording a still image and serving as a monitor when  
reproducing the recorded still image.

Digital images recorded by this type of digital camera can be easily  
30 processed using the software installed in a personal computer as one solely for  
processing such images. In the case of printing the images recorded by the  
digital camera, those images are sent from the digital camera to the personal  
computer. The personal computer executes the software and designates an  
image to be printed, in response to which the printer connected to the personal  
35 computer prints the image in colors.

The images recorded by the digital camera can be printed by means of a  
conventional printing system, as described above. However, in order to print

the images, those images have to be sent once to the personal computer from the digital camera, and then have to be output to the printer by executing the software so that the printer carries out a printing process. Thus, a computer such as a personal computer is essential to print the images obtained by the  
5 digital camera.

Moreover, software for sending the images obtained by the digital camera to the personal computer, image processing software for processing the images sent to the personal computer, and software for outputting the images as processed to the printer have to be installed.

10 In order to print the images obtained by the digital camera for the purpose of filing them in an album, for example, three apparatuses, i.e., the digital camera, the personal computer and the printer are needed. This results in a large-sized and considerably expensive printing system, the operation of which is so complicated that every user cannot quickly print the images by means of  
15 the printer with ease.

A printing system wherein the image data recorded in the digital camera is transferred directly to the printer and is printed is also available. However, in the case of the printer used in such a system, the resolution of the image data in the printer needs conversion, and an input apparatus like the aforementioned  
20 host equipment is necessary. This results in the printer being large-sized as well, and because of its price and the area occupied thereby, the printer is not in general use as a popular electronic apparatus.

#### Disclosure of Invention

The present invention has been made in consideration of the above, and  
25 it is accordingly an object of the present invention to provide a printing apparatus by which any user can easily print the image data recorded in the image recording apparatus.

It is a further object of the present invention to provide a printing apparatus and a printing system employing the same wherein the image  
30 recording apparatus is connected to the printing apparatus with no personal computer being provided therebetween, due to which the system is smaller-sized and operations for printing a recorded image are simpler.

It is a further object of the present invention to provide a printing apparatus which can receive image data of the desired resolution from the  
35 image recording apparatus and which can print the received image data without changing the resolution of the image data.

It is a further object of the present invention to provide a printing

apparatus wherein the display of information as to the internal condition of the image recording apparatus and the printing of the image data stored in the image recording apparatus can be performed by controlling the image recording apparatus.

5       According to the first aspect of the present invention having the above-described objects, there is provided a printing apparatus which is detachably connected to an image recording apparatus and which is capable of communicating the image recording apparatus, the image recording apparatus comprising image fetching means for fetching, as digital signals, image  
10 information units each representing a still image, an image memory for storing the image information units fetched by the image fetching means, display means for displaying the image information units stored in the image memory, and control means for controlling the image memory and the display means in accordance with an externally received control signal. The above printing  
15 apparatus comprises:

input means for inputting control signals;

first control means for receiving a first control signal input from the input means and sending the first control signal to the control means of the image recording apparatus, in order to cause the control means of the image recording  
20 apparatus to read out at least one of the image information units stored in the image memory, and in order to cause the display means to display the image represented by the aforementioned at least one image information unit read out from the image memory;

second control means for receiving a second control signal input from the  
25 input means and sending the second control signal to the control means of the image recording apparatus, in order to cause the control means of the image recording apparatus to output the aforementioned at least one image information unit representing the image displayed on the display means to the printing apparatus;

30 image information receiving means for receiving the aforementioned at least one image information unit output from the image recording apparatus; and

printing means for printing on a recording medium the image represented by the aforementioned at least one image information unit received by the  
35 image information receiving means.

In the printing apparatus having the above-described structure, when the first control signal is input from the input means of the printing apparatus, the

first control signal is sent to the image recording apparatus. When the image recording apparatus receives the first control signal, the images stored in the image memory are selectively displayed on the display means of the image recording apparatus. When the second control signal is input from the input 5 means of the printing apparatus under the condition wherein the desired one of the images is being displayed on the display means, the second control signal is sent to the image recording apparatus. When the image recording apparatus receives the second control signal, the image which is being displayed on the display means is transferred from the image recording 10 apparatus to the printing apparatus. The image as transferred is printed by the printing means. Thus, a user can print the desired image only by inputting the control signals from the input means of the printing apparatus.

The above printing apparatus may further comprise:

third control means for receiving a third control signal input from the input 15 means and sending the third control signal to the control means of the image recording apparatus, in order to cause the control means of the image recording apparatus to set the direction of an image to be displayed on the display means; and

storing means for storing direction information corresponding to the 20 direction set by the control means of the image recording apparatus when the third control signal is input from the input means, the printing means printing the image represented by the aforementioned at least one image information unit received by the image information receiving means, in accordance with the direction information stored in the storing means.

25 In that case, the third control signal may include data specifying the direction of the image to be displayed on the display means.

In the above printing apparatus, the image information receiving means may receive image information output from the image recording apparatus in the form of compressed data.

30 In that case, it is preferred that the printing apparatus further comprise expanding means for expanding the image information received by the image information receiving means, and the printing means prints an image represented by the image information expanded by the expanding means on the recording medium.

35 The above printing apparatus may further comprise:

format storing means for prestoring print format data representing print formats and selection display menu data for selecting the desired one of the

print formats;

fourth control means for receiving a fourth control signal from the input means and sending, together with the fourth control signal, the selection display menu data stored in the format storing means to the control means of the image recording apparatus, in order to cause the control means of the image recording apparatus to display on the display means an image corresponding to the selection display menu data;

selecting means for selecting one of the print formats, based on the image corresponding to the selection display menu data and displayed on the display means; and

print data producing means for producing print data representing an image to be printed, based on at least the image information received from the image recording apparatus and the print format data selected by the selecting means, and for supplying the print data to the printing means.

The above printing apparatus may further comprise time measuring means for measuring time information. In this case, it is preferred that the print formats include a print format having an area in which an image corresponding to the time information measured by the time measuring means is to be printed, and that the print data producing means produce the print data, based on the image information received from the image recording apparatus, the print format data selected by the selecting means and the time information measured by the time measuring means.

The above printing apparatus may further comprise power source control means for shutting off a supply of power to the printing apparatus when no control signal is input the input means for a predetermined period of time.

According to the second aspect of the present invention, having the above-described objects, there is provided a printing apparatus which is detachably connected to an image recording apparatus via communication means. The image recording apparatus stores digital signals obtained from an optical image formed by a lens unit in an image memory as image data, and sends data including the image data to the printing apparatus through the communication means, and receives control signals or data containing the image data from the printing apparatus, and displays on display means the image data stored in the image memory or the image data received through the communication means, in accordance with a control performed by control means. The printing apparatus comprises:

storing means for storing printer operation image data for causing the

display means to display an image for selecting the desired one of a plurality of formats, and for storing image data corresponding to the formats;

first control means for sending the printer operation image data to the communication means of the image recording apparatus, in order to cause the  
5 control means of the image recording apparatus to display on the display means an image corresponding to the printer operation image data;

format selecting means for selecting desired one of the formats in accordance with the image corresponding to the printer operation image data and displayed on the display means;

10 second control means for sending a first control signal to the control means through the communication means, in order to cause the control means of the image recording apparatus to read out the image data stored in the image memory and display the read-out image data on the display means;

image selecting means for selecting desired image data among the image  
15 data displayed on the display means;

format image reading means for reading out, from the storing means, image data corresponding to the format selected by the format selecting means;

third control means for sending a second control signal corresponding the image data selected by the image selecting means to the control means through  
20 the communication means of the image recording apparatus, in order to cause the control means to read out from the image memory the image data selected by the image selecting means and send the read-out image data through the communication means;

receiving means for receiving the image data sent through the  
25 communication means in response to the second control signal sent from the third control means;

print image producing means for producing print image data representing an image to be printed, based on the image data read out by the format image reading means and the image data received by the receiving means; and

30 printing means for printing the print image data produced by the print image producing means on a recording medium.

In the above printing apparatus, the printer operation image data stored in the storing means provided in the printing apparatus is transferred from the printing apparatus to the image recording apparatus, and is displayed on the  
35 display means of the image recording apparatus as a printer operation image, i.e., a format selection menu for selecting one of a plurality of formats. Viewing the image displayed on the display means, the user can select one of the



formats by the selecting means, and can further select image data from the image data recorded in the image recording apparatus. The image corresponding to the format thus selected is read out from the storing means of the printing apparatus. The image data stored in the image memory of the  
5 image recording apparatus is sent to the printing apparatus. The print image producing means produces print image data on the basis of the selected format and the received image data, and the image corresponding to the print image data is printed on a recording medium by the printing means.

With the above-described structure, the printing apparatus can be  
10 connected to the image recording apparatus, and the printer operation image can be displayed on the display means of the image recording apparatus in accordance with control information sent from the printing apparatus. Viewing the printer operation image displayed on the display means, the user can select one of the formats and image data. This permits an image recorded by the  
15 image recording apparatus to be easily printed without a computer such as a personal computer between the printing apparatus and the image recording apparatus.

Since the desired one of the formats for printing can be selected with the operation image being displayed on the display means of the image recording  
20 apparatus, it is not necessary to provide the printing apparatus with such a display means, which enables the printing apparatus to be compact.

In the above printing apparatus, the image data stored in the storing means may be compressed data. In this case, it is preferred that the print image producing means include expanding means for expanding the image  
25 data.

In the above printing apparatus, the image data received by the receiving means from the image recording apparatus may be compressed data. In this case, it is preferred that the print image producing means include expanding means for expanding the image data.

30 According to the third aspect of the present invention having the above-described objects, there is provided a printing system wherein image data representing still images recorded by and kept in an image recording apparatus are transferred to a printing apparatus and are printed by the printing apparatus. The printing system comprises:

35 storing means for prestoring printer operation image data for selecting desired one of a plurality of formats, and image data corresponding to the formats;

display means for displaying an image corresponding to the printer operation image data which is read out from the storing means, and for displaying at least one of the images represented by the image data kept in the image recording apparatus;

- 5 selecting means for selecting desired one of the formats in accordance with the printer operation image data displayed on the display means, and for selecting desired image data from image data displayed on the display means;
- print data producing means for producing print image data to be printed, based on the image data kept in the image recording apparatus and selected by
- 10 the selecting means and the image data corresponding to the format selected by the selecting means and stored in the storing means;
- printing means for printing the image data produced by the print data producing means on a recording medium.

In the above printing system, it is preferred that the printing apparatus be

15 provided with the storing means, the selecting means, the print data producing means and the printing means, for example. Meanwhile, it is preferred that the image recording apparatus be provided with the display means.

According to the above-described printing system, the printer operation image stored in the storing means can be displayed on the display means, and

20 one of the formats can be selected based on the displayed printer operation image. The print data producing means produces print image data to be printed, on the basis of the image data transferred from the image recording apparatus and the image data corresponding to the selected format. The printing means prints the image corresponding to the print image data as

25 produced. In this manner, images recorded in the image recording apparatus can be printed with easy operations.

According to the above printing system wherein the printing apparatus has the storing means, the selecting means and the print data producing means and wherein the image recording apparatus has the display means, it is not

30 necessary to provide a computer such as a personal computer between the printing apparatus and the image recording apparatus. Since printing can be performed with the image recording apparatus and the printing apparatus being connected to each other without such a computer therebetween, a smaller-sized printing system can be realized. By eliminating the need to provide a

35 computer between the printing apparatus and the image recording apparatus, the need to employ software only for linking the computer and the image recording apparatus together is also eliminated.

In the above printing system, the printer operation image data may be compressed data. In this case, the printing system may further comprise expanding means for expanding the printer operation image data, and the display means displays an image corresponding to the printer operation image data expanded by the expanding means.

In the above printing system, the image data kept in the image recording means may be compressed data. In this case, the printing system may further comprise expanding means for expanding the image data, and the display means displays images corresponding to the image data expanded by the expanding means.

According to the fourth aspect of the present invention having the above-described objects, there is provided a printing apparatus which receives recorded image data from an image recording apparatus and which prints an image corresponding to the received image data. The image recording apparatus comprises display means having a function of displaying a still image while being recorded in a recording mode and a function of displaying the recorded still image in a playback mode. The printing apparatus comprises:

- storing means for storing operation display data required to perform a print operation;
- first control means for transferring the operation display data stored in the storing means to the image recording apparatus in order to cause the image recording apparatus to display on the display means an image corresponding to the operation display data;
- print commanding means for generating a command to perform the print operation in accordance with the image corresponding to the operation display data and displayed on the display means;
- second control means for causing the image recording means to transfer the recorded image data, in response to the command generated by the print commanding means; and
- printing means for printing the image corresponding to the recorded image data transferred from the image recording means on a printing sheet.

With the above printing apparatus, the images recorded by the image recording apparatus can be printed without a personal computer being provided between the printing apparatus and the image recording apparatus. The image corresponding to the operation display data necessary to make the printing apparatus execute printing can be displayed on the display means of the image recording apparatus which functions as both a finder and monitor.

Therefore, even if the printing apparatus does not have a satisfactorily large-sized display section, the user can operate the printing apparatus while viewing the image displayed on the display means of the image recording apparatus.

Since the operation display data can be displayed on the display means  
5 of the image recording apparatus, the printing apparatus may have no display means for displaying the operation display data necessary to make the printing apparatus to execute printing.

According to the fifth aspect of the present invention having the above-described objects, there is provided a printing apparatus which is detachably  
10 connected to an image recording apparatus via communication means. The image recording apparatus stores digital signals obtained from an optical image formed by a lens unit in an image memory as image data, and sends data including the image data to the printing apparatus through the communication means, and receives control signals or data containing the image data from the  
15 printing apparatus, and displays on display means the image data stored in the image memory or the image data received through the communication means, in accordance with a control performed by control means. The printing apparatus comprises:

printing means for printing, at a predetermined resolution, an image  
20 corresponding to the image data transferred from the image recording means on a recording medium and;

print control means for sending an image transfer request signal to the control means of the image recording apparatus through the communication means in order to make the control means change the resolution of the image  
25 data stored in the image memory to a resolution suitable for being printed by the printing means and transfer the image data whose resolution has been changed, the printing means printing the image corresponding to the image data transferred from the image recording means on the recording medium, without changing the resolution of the image data transferred from the image recording  
30 means.

With the above printing apparatus, the images recorded by the image recording apparatus can be printed without a personal computer being provided between the printing apparatus and the image recording apparatus. An image whose resolution has been changed to that suitable for being printed by the  
35 printing apparatus is transferred to the printing apparatus, and is printed thereby. Due to this, the printing apparatus can print the image at the appropriate resolution, without the function of changing the resolution, in other

words, without a circuit for changing the resolution. Since such a resolution changing circuit is not required, the printing apparatus is smaller-sized accordingly, with the result that the printing apparatus can be manufactured at a lower cost. After the resolution of the image data has been changed, the  
5 printing apparatus receives the image data from the image recording apparatus and prints the received image data. Under this condition, the image data of the amount according to the resolution of the image to be printed can be transferred from the image recording apparatus. This ensures high-speed data transfer and a high-speed printing process. In the above printing apparatus, the image  
10 data immediately before printed and whose resolution has been changed can be stored temporarily. In other words, the image data to be printed can be temporarily stored as 1-frame image data. This allows the memory capacity to be reduced, permitting the cost of manufacturing the printing apparatus to be further lowered.

15 In the above printing apparatus, the print control means may send to the control means an image transfer request signal for requesting the transfer of image data representing images the number of which is  $n$ . In this case, the control means changes the resolution of the image data representing the images, the number of which is  $n$ , to a resolution of  $1/n$ , and the printing means  
20 prints the images corresponding to the image data transferred from the image recording apparatus, without changing the resolution of the image data.

According to the sixth aspect of the present invention having the above-described objects, there is provided a printing system wherein image data representing still images recorded by and kept in an image recording apparatus  
25 are transferred to a printing apparatus and are printed by the printing apparatus. The image recording apparatus comprises resolution changing means for changing the resolution of the image data kept in the image recording apparatus to a resolution suitable for being printed by the printing apparatus, and transfer means for transferring to the printing apparatus the image data  
30 whose resolution has been changed. The printing apparatus prints images corresponding to the image data transferred by the transfer means on a printing medium, without changing the resolution of the image data transferred by the transfer means.

With the above printing system, the images recorded by the image  
35 recording apparatus can be printed without a personal computer being provided between the printing apparatus and the image recording apparatus. An image whose resolution has been changed to that suitable for being printed by the

printing apparatus is transferred to the printing apparatus and is printed thereby. Due to this, the printing apparatus can print the image at the appropriate resolution without the function of changing the resolution, in other words, without a circuit for changing the resolution. Since such a resolution changing circuit is not required, the printing apparatus is smaller-sized accordingly, with the result that the printing apparatus can be manufactured at a lower cost. In the above printing system, since the printing apparatus receives the image data of a resolution suitable for being printed thereby from the image recording apparatus, the printing apparatus can print the image at high speed.

10 According to the above printing system, data according to the resolution of the image to be printed can be transferred from the image recording apparatus to the printing apparatus. This ensures high-speed data transfer and a high-speed printing process. In the printing apparatus of the above printing system, the image data immediately before printed and whose resolution has been  
15 changed can be stored temporarily. In other words, the image data to be printed can be temporarily stored as 1-frame image data. This enables the memory capacity to be reduced, permitting the cost of manufacturing the printing apparatus to be further lowered.

According to the seventh aspect of the present invention having the  
20 above-described objects, there is provided a printing apparatus which is detachably connected to an image recording apparatus via communication means. The image recording apparatus stores digital signals obtained from an optical image formed by a lens unit in an image memory as image data, and sends data including the image data to the printing apparatus through the  
25 communication means, and receives control signals or data containing the image data from the printing apparatus, and displays on display means the image data stored in the image memory or the image data received through the communication means, in accordance with a control performed by control means. The printing apparatus comprises:

30 first commanding means for commanding the control means of the image recording apparatus to transfer information pertaining to the internal condition of the image recording apparatus;

display control means for producing display data on the basis of the information pertaining to the internal condition of the image recording apparatus  
35 and transferred from the image recording apparatus, and for outputting the display data to the control means in order to display an image corresponding to the display data on the display means;

second commanding means for commanding the control means of the image recording apparatus to transfer the image data stored in the image memory; and

printing means for printing on a recording medium an image  
5 corresponding to the image data transferred from the image recording apparatus in response to the command generated by the second control means.

With the above printing apparatus, the images recorded by the image recording apparatus can be printed without a personal computer being provided between the printing apparatus and the image recording apparatus. The  
10 above printing apparatus transfers to the image recording apparatus the display data produced based on data transferred from the image recording apparatus. The display data as transferred is displayed on the display means. Therefore, even if the image recording apparatus does not have the function of displaying the number of images which have been recorded by the image recording  
15 apparatus and the number of images which can be further recorded by the image recording apparatus, the number of images as recorded and/or the number of images which can be further recorded can be displayed. Thus, using the above printing apparatus, the information as to the images stored in the image recording apparatus can be easily attained.

20 More specifically, according to the above printing apparatus, the aforementioned information pertaining to the internal condition of the image recording apparatus may be data representing the number of still images stored in the image memory of the image recording apparatus. In this case, it is preferred that the display control means transfer, to the image recording  
25 apparatus, the display data produced on the basis of the data representing the number of still images stored in the image memory, and that the display means display the display data, thereby indicating the number of still images stored in the image memory.

In the above printing apparatus, the aforementioned information  
30 pertaining to the internal condition of the image recording apparatus may be data representing the number of still images which can be further stored in the image memory. In this case, it is preferred that the display control means transfer to the image recording apparatus the display data produced on the basis of the data representing the number of still images which can be further  
35 stored in the image memory, and that the display means display the display data, thereby indicating the number of still images which can be further stored in the image memory.

### Brief Description of Drawings

Fig. 1 is a diagram which shows the appearance of a digital camera 10 and that of a printer 20 for the digital camera, according to the first embodiment of the printing apparatus of the present invention.

5 Fig. 2 is a block diagram which shows the structures of the electronic circuits in the digital camera shown in Fig. 1 and having an LCD and the structures of the electronic circuits in the printer shown in Fig. 1.

Fig. 3A is a diagram showing postcard printing format patterns prestored in a ROM of the printer.

10 Fig. 3B is a diagram showing calendar printing format patterns prestored in the ROM of the printer.

Fig. 4 is a flowchart showing an image data printing process performed by the printer.

15 Fig. 5 is a diagram showing in what state a printing direction indicating mark is displayed subsequent to the image data printing process performed by the printer.

Fig. 6 is a diagram showing a calendar created and printed by the image data printing process performed by the printer.

20 Fig. 7 is a perspective view showing the state in which a digital camera and a printer according to the second embodiment of the present invention are connected to each other.

Fig. 8 is a block diagram showing the circuits of the digital camera and those of the printer, according to the second embodiment of the present invention.

25 Fig. 9 is a diagram showing how drivers and sensors according to the second embodiment of the present invention are connected to one another.

Fig. 10 is a diagram showing the state of an initial menu displayed on the viewfinder of the digital camera when the digital camera and the printer are connected to each other and are turned on.

30 Figs. 11A to 11F are diagrams showing examples of the display changing upon the depressions of keys in an "easy print mode"

Figs. 12A to 11C are diagrams showing other examples of the display changing upon the depressions of the keys in the "easy print mode".

35 Figs. 13A to 13E are diagrams showing other examples of the display changing upon the depressions of the keys in the "easy print mode".

Figs. 14A to 14E are diagrams showing other examples of the display changing upon the depressions of the keys in the "easy print mode".



Figs. 15A to 15C are diagrams illustrating the first to third pages of a layout/background printing menu, each of the first to third pages displaying six icons representing image layout forms.

Fig. 16 is a diagram illustrating a background selection menu with icons for selecting one of backgrounds which is to be combined with a selected image.

Fig. 17 is a diagram showing a calendar printing menu with icons for selecting the layout of the calendar to be combined with the selected image.

Figs. 18A to 18C are diagrams showing three examples of calendars printed with being combined with images.

10 Fig. 19A is a diagram showing an example of a mini label printing menu with icons for selecting one of decoration patterns which is to be combined with a selected image such as a the photograph of a face.

Fig. 19B is a diagram showing an example of sixteen mini labels bearing the same image which is the combination of the photograph of a face and one  
15 decoration pattern.

Fig. 20A is a diagram illustrating a postcard printing menu with icons for selecting one of patterns which is to be combined with an image selected to form a postcard, and the patterns standing for various festivals.

Fig. 20B is a diagram illustrating an illustration combined printing menu  
20 with icons for selecting one of decoration frame patterns which is to be combined with a recorded image in order to form an collage image.

Figs. 21A to 21C are diagrams showing examples of the display when an "INDEX" icon is selected.

Fig. 22 is a general flowchart which shows image displaying and printing  
25 processes.

Fig. 23 is a flowchart showing a printing process

Fig. 24 is a flowchart showing an image selecting process.

Fig. 25 is a flowchart showing an image direction setting process.

Fig. 26 is a diagram showing the process of printing an image combined  
30 with a background.

Fig. 27 is a flowchart showing the process of printing an image combined with a calendar.

Fig. 28 is a flowchart showing the process of printing mini labels.

Fig. 29 is a flowchart showing the process of printing a postcard.

35 Fig. 30 is a flowchart showing the process of printing the list (index) of all of the images recorded as photographs.

Figs. 31A to 31C are diagrams showing how an image setting menu, a

year setting menu and a month setting menu are displayed.

Figs. 32A to 32C are diagrams illustrating character display menus on which the number of recorded images is displayed and a character display menu which inquires the user as to whether to perform printing or not.

5                                   Best Mode for Carrying out the Invention  
  First Embodiment

The first embodiment of the present invention will now be described with reference to the accompanying drawings.

Fig. 1 is a diagram showing the appearance of an electronic still camera  
10 (hereinafter referred to as a digital camera) 10 and that of a printer 20.

The digital camera 10 comprises two blocks, i.e., a camera main body 11 and a lens unit section 12.

A liquid crystal display section 13 is arranged on the back surface (which appears to be the front surface in the illustration) of the camera main body 11.

15       When recording the image of the object to be photographed, the liquid crystal display section 13 serves as a viewfinder for displaying the object. When reproducing the image, the liquid crystal display section 13 serves as a monitor for displaying the image data as recorded. A function switching key 14 for performing switching between an image recording mode (RE) and an image  
20 playback mode (PL) is provided beside the liquid crystal display section 13.

Arranged on the upper surface of the camera main body 11 are a power source switch 15 for turning on/off the camera, a shutter button 16 used to photograph the object displayed on the liquid crystal display section in the image recording mode, a "+" key 17a and a "-" key 17b both for selecting image  
25 data to be displayed on the liquid crystal display section 13 in the image playback mode (PL), and a communication terminal 18 through which the image data and various command signals are input/output.

A normal lens and a close-up lens are arranged on the front face (not shown) of the lens unit 12 so as to be changeable from one to the other and vice  
30 versa. A photographing mode changing switch for changing two photographing modes, i.e., a normal photographing mode and a close-up photographing mode from one to the other and vice versa, is provided on the left side (not shown) of the lens unit 12.

The lens unit 12 is attached to the camera main body 11 so that the lens  
35 unit 12 can be rotated 90° forward and 180° backward.

Arranged on the upper surface of the printer 20 are a printing sheet confirmation window 12 through which an image printing sheet X can be

confirmed, a power source key 22 for turning on/off the printer, a "+" key 23a and a "-" key 23b both for selecting menu data on a menu and the image data to be printed, a "SET" key 24 for determining the image data selected as that to be printed, a direction switching key 25 for switching and setting the direction of the  
5 image of the object photographed with the digital camera 10 being held vertically, a "MENU" key 26 for causing a print menu for the selection of a print mode among a normal print mode, a postcard print mode and a calendar print mode to be displayed, and a "PRINT" key 27 for issuing a command to start printing the image data. A communication terminal 28 through which an image  
10 data input command signal, an image data output command signal and other various command signals are input/output is provided on the upper face of the printer 20.

A sheet discharge slot 30 through which the printing sheet X with an image printed thereon is discharged is formed on the right side of the printer 20.

15 The communication terminal 18 of the digital camera 10 and the communication terminal 28 of the printer 20 are detachably coupled to each other with a communication cable 29.

Fig. 2 is a block diagram showing the structures of electronic circuits in the digital camera 10 and in the printer 20.

20 The digital camera 10 comprises electronic circuits which are CCD 31, an A/D converter 32, a timing generator 33, a driving circuit 34, a compression/expansion circuit 35, a DRAM 36, an image memory 37, a control circuit 38, a ROM 39, a RAM 40, a key input section 41, a CPU 42, a signal generator 43, a VRAM 44, a D/A converter 45, a liquid crystal display section 13  
25 and an I/O interface 46.

The CCD 31 converts a light signal representing a still image formed by a lens unit 12a to an analog electric signal. Color filters for a plurality of colors are arranged in a predetermined order in front of the CCD 31. The A/D converter 32 converts the analog signal to digital signals. The timing  
30 generator 33 generates a timing signal for controlling the drive circuit 34 which drives the CCD 31. The compression/expansion circuit 35 compresses/expands digital image signals. The DRAM 36 temporarily stores the digital image signals sent thereto. The image memory 37 is a flash memory and stores the compressed image signals. The memory control circuit  
35 38 controls an address at the time of writing/reading the image data in/from the DRAM 36 and the image memory 37. The ROM 39 stores system programs for all operations of the digital camera 10 which include operations when a

communication link is established between the digital camera 10 and the printer 20. The key input section 41 has the power source switch 15, the shutter button 16, the "+" key 17a and the "-" key 17b. Using the RAM 40 as a work area, the CPU 42 executes a system program stored in the ROM 39, in response to an input from the key input section 41. The signal generator 43 generates digital video signals by adding sync signals to the digital image signals. The VRAM 44 stores the digital video signals corresponding to the image displayed on the liquid crystal display section 13. The D/A converter 45 converts the digital video signals output from the signal generator 43 to an analog signal. The liquid crystal display section 13 displays an image by driving the liquid crystal in accordance with the analog video signal to which the digital video signals have been converted. The I/O interface 46 outputs to the printer 20 the image data converted to serial data by the CPU 42, and receives various control information (command signals) from the printer 20.

In the digital camera 20, the timing generator 33 outputs a timing signal in a predetermined cycle. The drive circuit 34 is controlled by the timing signal, and the photo signal corresponding to the formed image of the object to be photographed is fetched into the CCD 31. The fetched photo signal is converted by the A/D converter 32 from an analog signal to digital signals, and is temporarily stored in the DRAM 36 as digital image signals.

The digital image signals stored in the DRAM 36 have color components such as Yellow (Ye), Cyan (Cy), Green (Gr), etc., since the light signal corresponding to the image formed by the lens unit 12a is one which has passed through the color filters arranged in front of the CCD 31.

The CPU 42 generates, by the image processing in a high-speed mode, an image signal used to monitor the object to with the liquid crystal display section 13, and generates, by the image processing in a high-image-quality mode, an image signal used to record the image of the object.

First of all, the CPU 42 executes the processing required for generating luminance signals based on thinned information. The luminance signals are generated using, for example, only a Ye-component signal of Ye-, Cy- and Gr-component signals read out from the DRAM 36. In this case, pixels or digital signals stored in the DRAM 36 are thinned out, and Ye-component data of three pixels including the aforementioned Ye-component signal is caused to pass through a prefilter comprising a low-pass filter (LPF), and then is subjected to the  $\gamma$ -correction (since the  $\gamma$ -characteristic of the liquid crystal display is not linear, the image data is corrected in advance such that a linear luminance is

achieved when the image corresponding to the image data is displayed on the liquid crystal display), thus generating the luminance signals.

Following the above, the CPU 42 executes the processing required for generating chrominance signals corresponding to the luminance signals which 5 have been generated with the pixels being thinned out.

When generating the chrominance signals, the Ye-, Cy- and Gr-component signals read out from the DRAM 36 are thinned out to 1/6, and data of six pixels including the resultant signal is generated. The data as generated is made to pass through the prefilter. The Ye-, Cy- and Gr-component signals 10 which have passed through the prefilter are subjected to the correction known as white balance (this correction is one for compensating for the nonuniformity of chrominance signals due to the differences in the characteristics of the color filters, and is performed so that white is displayed in white), and then are subjected to a color arithmetic operation, whereby R-Y and B-Y chrominance 15 signals are generated.

The luminance signals and the chrominance signals thus generated are transferred to the signal generator 43. The signal generator converts the luminance signals and the chrominance signals to a video signal. The liquid crystal display section 13 displays, serving as a monitor, the image of the object 20 to be photographed.

When an operation signal is input from the key input section 41 by depressing the shutter button 16, the CPU 42 executes the processing required for generating luminance signals for a high-quality image.

When generating those luminance signals, data of seven pixels including 25 signals read out from the DRAM 36 is generated. The data as generated is caused to pass through the prefilter, and then is subjected to the  $\gamma$ -correction in order to adjust moire balance. By adjusting the moire balance, the nonuniformity of the luminance signals due to the differences in the characteristics of the color filter are compensated for.

30 By causing the moire-balanced signals to pass through the LPF, noises of a high-frequency component are reduced. Then, an enhancing process is performed, thus generating the luminance signals.

The CPU 42 next executes the processing required for generating chrominance signals corresponding to the luminance signals for a high-quality 35 image.

When generating those chrominance signals, data of twelve pixels including the Ye-, Cy- and Gr-component signals read out from the DRAM 36

are caused to pass through the prefilter. The Ye-, Cy- and Gr which have passed through the prefilter are subjected to the correction known as white balance, and then are subjected to the arithmetic operation, whereby the R-Y and B-Y signals are generated.

5 The luminance signals and the chrominance signals thus generated are transferred to the compression/expansion circuit 35. The compression/expansion circuit 35 encodes and compresses the luminance and chrominance signals into a compressed image signal, and transfers the image signal (the luminance signals and the chrominance signals) to the image  
10 memory 37 so as to be stored therein.

In the case of reproducing the image signal, a signal for causing switching to the image reproducing mode is input from the key input section 41 to the CPU 42 by depressing the function switching key 14. Upon the input of the signal to the CPU 42, the compressed image signal (the compressed luminance and  
15 chrominance signals) stored in the image memory 37 is transferred to the compression/expansion circuit 35.

The compression/expansion circuit 35 expands those luminance and chrominance signals. The signal generator 43 generates digital video signals by adding sync signals to the expanded luminance and chrominance signals,  
20 and inputs the digital video signals to the liquid crystal display section 13 through the D/A converter 45. The liquid crystal display section 13 displays an image corresponding to the video signals.

In this case, the compressed image signal to be read out from the image memory 37 is changed in accordance with the depression of the "+" key 17a and  
25 the "-" key 17b, whereby the image data to be displayed on the liquid crystal display section 13 is selected.

The printer 20 includes electronic circuits which are CPU 51, a key input section 52, a ROM 53, a RAM 54, an I/O interface 55, a clock circuit 56, a timing generator 57, an image memory 58, an expansion circuit 59, a print buffer 60  
30 and a color printer section 61.

In response to an input from the key input section 52, the CPU 51 executes a system program stored in the ROM 53, using the RAM 54 as a work area. The CPU 51 has the function to shut off the supply of power to the printer 20 by turning off the power source unit (not shown) in accordance with  
35 an internal timer. Various command signals obtained by the CPU 51 are output through the I/O interfaces 46 and 55 to the digital camera 10, and the image data from the digital camera 10 are input through the I/O interface 46.

The clock circuit 56 indicates date and time. The timing generator 57 outputs a timing signal for attaining a synchronization with an image signal input/output to/from the CPU 51. The image memory 58 stores compressed image data input from the digital camera 10 through the I/O interface 55. The expansion circuit 59 reads out the compressed image data from the image memory 58, and expands the compressed image data as read out. Print buffer 60 stores, as print data, the image data expanded by the expansion circuit 59. The color printer section 61 has yellow, magenta and cyan ink ribbons, and prints an image corresponding to the print data stored in the print buffer 60 on the printing sheet X by a thermal transfer method.

The key input section 52 has the power source key 22, the "+" key 23b, the "-" key 23b, the "SET" key 24, the layout changing key 25, the "MENU" key 26 and the "PRINT" key 27.

The RAM 54 includes a mode data register (M) 54a which is set at "0", "1", "2" and "3" in a menu display mode, the normal print mode, the postcard print mode and the calendar print mode, respectively, a menu selection register (K) 54b in which flag data according to the print mode selected and designated on the print menu is set as "1", "2" and "3" in the normal print mode, the postcard print mode and the calendar print mode, respectively, and a printing direction setting register (P) 54c which is set at "0" when the image of the object photographed with the digital camera 10 being held horizontally is to be printed as is, and which is set at "1" when the image is to be printed so that the right side of the image is located above, and which is set at "2" when the image is to be printed so that the left side of the image is located above.

The ROM 53 stores in advance menu data to be displayed on the liquid crystal display section 13 of the digital camera 10, format pattern data for setting the format of the image data to be printed by the color printer section 61, etc., in addition to the system programs which the CPU 51 requires in order to control all operations of the printer 20 which include the print operation, the operation of expanding compressed data, the operation of creating a calendar and the operation of performing data communication with the digital camera 10.

The postcard printing format pattern shown in Fig. 3A has the combination of upper and lower areas, i.e., a horizontal layout area A1 in which an image is laid out horizontally and a ruled line print area A2. The calendar printing format pattern shown in Fig. 3B has the combination of a vertical layout area A3 in which an image is laid out vertically and a calendar print area A4.

Compressed image data read out from the image memory 10 of the digital

camera 10 in response to a command from the CPU 51 of the printer 20 and sent through the I/O interfaces 46 and 55 is temporarily stored in the image memory 58. The compressed image data stored in the image memory 58 is expanded by the expansion circuit 59. The image data expanded by the expansion circuit 59 is sent to the print buffer 60 in combination with the printing format pattern stored in the ROM 53 and corresponding to the print mode designated by the mode data register (M) 54a in the RAM 54, and is printed out by the color printer section 61.

In this case, date data for the calendar printing format pattern is processed on the basis of the present date and day of the week, and is laid out in the calendar print area A3.

The image printing operation of the printer 20 will now be described.

Fig. 4 shows a flowchart showing the process of printing an image stored in the digital camera 10 with the printer 20.

The process shown in this flowchart is carried out under the conditions wherein the desired objects are photographed using the digital camera 10, wherein the compressed image data representing the images of the objects as photographed are stored in the image memory 37, and wherein the communication terminal 18 of the digital camera 10 and the communication terminal 28 of the printer 20 are connected to each other with the communication cable 29.

When the "ON" key 22 on the printer 20 is depressed (step R1), the mode flag M in the mode data register 54a of the RAM 54 is set at the initial value "0" (step R2), and the print menu flag K in the menu selection register 54b is set at the initial value "1" (step R3).

Menu data stored in advance in the ROM 53 of the printer 20 and used to select a print menu is read out and sent to the CPU 51. The menu data as read out is output together with a menu display command signal to the communication cable 29 through the I/O interface 55, and is transferred to the CPU 42 of the digital camera 10 (step R4).

When the menu data and the menu display command signal are transferred from the printer 20 to the CPU 42 of the digital camera 10, a video signal corresponding to the menu is generated by the signal generator 43. The print menu for displaying the characters "Normal Print", "Postcard Print" and "Calendar Print" in accordance with the video signal generated by the signal generator 43 is displayed on the liquid crystal displays section 13 of the digital camera 10 (step R5).



When the "+" key 23a or the "-" key 23b of the key input section 52 of the printer 20 is depressed while the print menu is being displayed on the liquid crystal display section 13 of the digital camera 10 (step R6), it is determined whether the mode flag M stored in the mode data register 54 of the RAM 54 is "0", in other words, whether the present mode is the menu display mode (step R7).

When it is determined in the step R7 that the mode flag M stored in the mode flag register 54a of the RAM 54 is "0" which shows the menu display mode, the menu selection flag K set in the menu selection register 54b of the RAM 54 is incremented by 1 in the case where the "+" key 23a is operated, and is decremented by 1 in the case where the "-" key 23b is operated (step R8).

In response to a variation in the menu selection flag K in the menu selection register 54b of the RAM 54, a cursor moving command signal is output from the CPU 51, and is transferred to the digital camera 10 through the I/O interface 55 (step R9).

In the digital camera 10, a cursor is displayed and moved to indicate a print mode on the menu displayed on the liquid crystal display section 13 of the digital camera 10, in response to the cursor moving command signal transferred from the CPU 51 of the printer 20. In other words, in response to the operation of the "+" key 23a and the "-" key 23b, one of the print modes, i.e., the normal print mode, the postcard print mode and the calendar print mode is selected and designated on the liquid crystal display section 13 (step R10).

Let it be assumed that the calendar print mode is selected by moving the cursor on the print menu. When the "SET" key 24 of the key input section 52 is depressed under the condition wherein the menu selection flag K "3" has been set in the menu selection register 54b in the RAM 54 of the printer 20 (step R13), it is determined whether the mode flag M in the mode data register 54a is "0" which indicates the menu display mode (step R14). When it is determined that the mode flag M is "0", the mode flag M is also set at "3" which indicates the calendar print mode, in accordance with the menu selection flag K "3" (step R15).

When the mode flag M is set, a first-image readout command signal is output from the CPU 51 of the printer 20, and is transferred to the CPU 42 of the digital camera 10 through the I/O interface 55 (step R16).

In the digital camera 10, in response to the first-image readout command signal, compressed image data which precedes the others stored in the image memory 37 is read out therefrom, and is expanded by the

compression/expansion circuit 35. The expanded image data is converted to a video signal by the signal generator 43, and is input to the liquid crystal display section 13 through the D/A converter 45. The liquid crystal display section 13 displays the image corresponding to the input video signal (step R17).

5 When the "+" key 23a or the "-" key 23b of the key input section 52 is depressed while the image corresponding to image data taken by the digital camera 10 and stored in the image memory 37 is being displayed on the liquid crystal display section 13 (step R6), it is determined that any one of flags other than the flag "0" indicating the menu display mode, i.e., any one of the flags "1",  
10 "2" and "3" all indicating the print modes, has been set in the mode data register M in the RAM 54 (step R7). In this case, an image switching command signal is output from the CPU 51, and is transferred to the digital camera 10 through the I/O interface 55 (step R11).

In the digital camera 10, in response to the image switching signal  
15 transferred upon the depression of the "+" key 23a or the "-" key 23b of the printer 20, the stored image desired by a user is read out from the image memory 37. The image which is currently being displayed on the liquid crystal display section 13 is changed to the image readout from the image memory 37 (step R12). Specifically, when the "+" key 23a on the printer 20 is operated,  
20 the control information corresponding to the operation of the "+" key 23a is transferred to the digital camera 10. The CPU 42 of the digital camera 10 which has received the control information reads out, of the image data representing a plurality of still images and stored in the image memory 37, the image data subsequent to that which is currently being displayed on the liquid  
25 crystal display section 13. The liquid crystal display section then displays the image corresponding to the aforementioned subsequent image data.

As seen from the above, image data stored in the image memory 37 of the digital camera 10 is selected by operating the "+" key 23a or the "-" key 23b, and is displayed on the liquid crystal display section 13. When the direction  
30 changing key 25 is depressed while the selected image data is being displayed on the liquid crystal display section 13 (step R18), it is determined which of "0", "1" and "2" a printing direction flag P set in the printing direction setting register 54c is (step R19).

Figs. 5A and 5B show in what state a printing direction indicating mark is  
35 displayed following the image data printing process performed by the printer 20.

Fig. 6 illustrates a calendar created and printed by the image data printing process performed by the printer 20.

For example, as shown in Fig. 5A, when it is determined that the printing direction flag P set in the printing direction setting register 54c of the RAM 54 is "0" under the condition wherein an image taken with the digital camera 20 being held vertically is being displayed on the liquid crystal display section 13, in other words, when it is determined that the selected image data which is now being displayed will be printed as an image taken with the digital camera being held horizontally (step R19), the printing direction flag P is set at "1" in response to the depression of the direction changing key 25 (step R20). The CPU 51 outputs display data which commands that the image be printed so that its right side is located above, and the display data is transferred to the digital camera 10 through the I/O interface 55 (step R21).

Then, the image is displayed on the liquid crystal display section 13 of the printer 20, together with a printing direction indication mark m which points to the right side of the image in Fig. 5A, thereby indicating that the image is to be printed so that its right side is located above, (step R22).

When the direction changing key 25 of the key input section of the printer 20 is operated again, it is determined that the printing direction flag P is currently "1" (step R19), and the print direction flag P is set at "2" (step R20). The CPU51 outputs display data which commands that the image be printed so that its left side is located above (step R23), and the display data is transferred to the digital camera 10 through the I/O interface 55 (step R24).

Then, the image is displayed on the liquid crystal display section 13 of the digital camera 10, together with the printing direction indication mark m which points to the left side of the image in Fig. 5B, thereby indicating that the image is to be printed so that its left side is located above (step R22).

When the direction switching key 25 of the key input section 52 of the printer 20 is operated one more time, it is determined that the printing direction flag P is currently "2" (step R19), and the printing direction flag P is set at "0" (step R25).

Then, the printing direction indication mark M displayed together with the display data on the liquid crystal display section 13 of the digital camera 10 is deleted in order that the selected image data which is being currently displayed is printed as an image taken with the digital camera 10 being held horizontally.

For example, let it be assumed that the image data with the printing direction mark m shown in Fig. 5A and indicating that the image is to be printed so that its right side is located above is selected and displayed in the calendar print mode wherein the mode flag M = "3", the menu selection flag K = 3 and the

printing direction flag P = "1" have been set in the mode data register 54a, the menu selection register 54b and the printing direction setting register 54c in the RAM 54 of the printer, respectively. When the "PRINT" key 27 of the key input section of the printer 20 is depressed under the above-described condition 5 (step R32), the CPU 51 outputs a print command signal, and that signal is transferred to the digital camera 10 through the I/O interface 55 (step R33).

The CPU 42 reads out from the image memory 37 the image data corresponding to the image displayed on the liquid crystal display section of the digital camera 10 (step R34). The CPU 42 transfers the readout image data to the printer 20 through the I/O interface 46. The CPU 51 stores in the image memory 58 the image data transferred to the printer 20 (step R35).

The expansion circuit 60 expands the image data stored in the image memory 58 (step R36). The CPU 51 reads out the calendar printing format pattern (refer to Fig. 3(B)) stored in the ROM 53, in accordance with the mode flag M = "3" set in the mode data register 54a of the ROM 54. The CPU 52 combines the readout format pattern with the image data expanded by the expansion circuit 60, and stores the combination thereof as print data in the print buffer 60 (step R37).

In the step R37, the image data is combined with the format pattern in the following manner:

In accordance with the printing direction flag P = "1" in the printing direction setting register 54c, the image data expanded by the expansion circuit 59 is laid out in the vertical layout area A3 on the calendar printing format pattern read out from the ROM 53 in accordance with the mode flag M = "3" in the mode data register 54a, with the right side of the image being located above. Moreover, the date data is laid out in the calendar print area A4 on the aforementioned format pattern in accordance with the present date and day of the week which have been measured by the clock circuit 56.

The print data produced and stored in the print buffer 60 as the combination of the selected image data and the calendar printing format pattern is output to the color printer section 61, and the image corresponding to the print data is printed on the printing sheet X as shown in Fig. 6. The printing sheet X with the image printed thereon is discharged to the outside of the printer 20 through the print discharge slot 30 of the printer 20 (step R38).

When the "MENU" key 26 of the key input section 52 of the printer 20 is depressed (step R26), it is determined whether the mode flag M which is not "0" has been set in the mode data register 54a of the RAM 54. That is, it is

determined whether the printer is in one of the normal print mode, the postcard print mode and the calendar print mode (step R27). When it is determined that the printer 20 is in any one of the above-described modes, the mode flag M is reset at "0" (step R28), and the print menu flag K in the menu selection register 5 54b is also reset at "1" (step R29).

Then, the CPU 51 again reads out the menu data for selecting a print menu stored in advance in the ROM 53 of the printer 20. The menu data as read out is output to the communication cable 29 through the I/O interface 55, together with the menu display command signal, and is transferred to the digital 10 camera 10 (step R30).

When the menu data and the menu display command signal are transferred from the printer 20 to the CPU 42 of the digital camera 10, the video signal corresponding to the menu data is generated by the signal generator 43. The print menu for displaying the characters "Normal Print", "Postcard Print" or 15 "Calendar Print" in accordance with the video signal generated by the signal generator 43 is displayed again on the liquid crystal section 13 of the digital camera 10 (step R38).

Let it be assumed that none of the keys in the key input section 52 of the printer 20 are operated, no key operation signal is input to the CPU 51, and 20 the CPU 51 performs no control operation. When those states continue, the supply of power to the printer 20 is stopped (step R39).

Upon the depression of the "ON" key 22 on the printer 20, the menu data and the menu display command signal are transferred to the digital camera 10, and the print menu is displayed on the liquid crystal display section 13 of the 25 digital camera 10. When the "+" key 23a or the "-" key 23b is depressed, the cursor moving command signal is transferred to the digital camera 10 such that the cursor on the print menu moves to select and designate the print mode desired. When the "SET" key 24 is depressed, the image readout command is transferred to the digital camera 10, and stored image data is read out and is 30 displayed on the liquid crystal display section 13. When the "+" key 23a or the "-" key 23b is depressed, the image switching command signal is transferred to the digital camera 10, the image data is selectively displayed on the liquid crystal display section 13. When the direction switching key 25 is depressed, image direction setting data is transferred to the digital camera 10, and is 35 displayed as a mark on the liquid crystal display section 13. When the "PRINT" key 27 is depressed, the print command signal is sent to the digital camera 10, and the image data corresponding to the image which is being

displayed on the liquid crystal display section 13 is read out from the digital camera 10 and is sent to the printer 20. The image is printed in colors on the printing sheet X in accordance with the print mode and the image direction which have been set to the printer 20, and the printing sheet X bearing the  
5 image is discharged therefrom. Thus, with simple and easy operations on the part of the printer 20, images taken as photographs by the digital camera 10 through the use of the liquid crystal display section 13 can be selectively displayed and printed.

In the first embodiment, in the case of performing printing in accordance  
10 with the calendar printing format pattern, an image transferred from the digital camera 10 and that of a calendar based on the date measured by the timer circuit 56 are printed in separate areas. However, the image transferred from the digital camera 10 and that of the calendar can be printed with both images being superimposed on each other; for example, they can be printed with the  
15 calendar being superimposed as a white image on the image transferred from the digital camera 10.

In the first embodiment, an image can be printed in accordance with the format pattern stored in the ROM 53. By providing the key input section 52 of the printer 20 with, for example, alphabet keys and by enabling the characters  
20 desired by the user to be input, the image and the characters can be printed on the same printing sheet in accordance with the format pattern.

The recording medium on which an image is printed with the printer 20 of the first embodiment is not limited to the printing sheet X, and may be an adhesive label with a separable paper, or a transparent film. The color printer  
25 61 may print an image by employing systems such as an ink jet system other than the thermal printing system.

#### Second Embodiment

The second embodiment of the present invention will now be described with reference to the drawings.

30 Fig. 7 is a perspective view showing the state wherein an electronic still camera (digital camera) and a printer according to the second embodiment are connected to each other.

As shown in Fig. 7, a digital camera 101 has a camera main body 102 and a lens unit section 103.

35 Operation mechanisms (switches, etc.) are formed on the upper surface and back surface (appears to be the front surface in Fig. 7) of the camera main body 102. Nothing is arranged on the front surface (appears to be the back

surface in Fig. 7) of the camera main body 102, except a trademark and a decoration.

A large viewfinder 104 with a color LCD is arranged on the central portion of the back surface of the camera main body 102. A power source switch 105, 5 a mode changing switch 106 for switching an operation mode between an image recording mode (RE) and an image playback mode (PL) is arranged in the vicinity of the viewfinder 104. A shutter button 109, a "+" key 111 for causing recorded images to be sequentially read out and displayed, a "-" key 112 for causing the image preceding the image which is currently being viewed 10 to be displayed are arranged on the upper surface of the camera main body 102. A communication terminal 113 is provided in the vicinity of the "+" key 111 and the "-" key 112 and closer to the front surface of the camera main body 102 than those keys 111 and 112. A plug provided on one end of a cable 114 is inserted in the communication terminal 113.

15 The lens unit section 103 has a lens arranged on the front surface thereof (this lens is not shown in Fig. 7 since the back side of the digital camera is illustrated in that drawing). The lens unit section 103 is rotatably arranged on the camera main body 102, and can be rotated 90° in the direction of an arrow A shown in Fig. 7, and can be rotated 180° in the direction of an arrow B shown in 20 Fig. 7. When the lens unit section 103 is rotated 180° in the direction of the arrow B, the lens faces backward, and the lens position becomes reversed. However, this posture of the lens is detected by an internal circuit, and an image which is being recorded is automatically corrected to an electing image, and that electing image is displayed.

25 As shown in Fig. 7, a printer 115 has an insertion/discharge slot 116 formed on the front surface (the face in Fig. 7) of the printer main body. A printing sheet P is loaded into the printer through the slot 116, and the printing sheet P on which an image has been printed is discharged from the printer through the slot 116. The front part of the upper surface of the printer 115 is 30 slightly inclined downward, and an operation panel 117 is formed on that front part. A "-" key 118A, a "+" key 118b, a "SET" key 118c, a "POWER" key 118d, an "EASY" key 118e, a "MENU" key 118f, a "BACK" key 118g, all of which are push-button type, and a communication terminal 119 are provided on the operation panel 117. A plug provided on the other end of the communication 35 cable 114 is inserted in the communication terminal 119.

Fig. 8 is a block diagram showing the circuits of the digital camera 101 and printer 115, both shown in Fig. 7.

The digital camera 101 includes electronic circuits which are a timing generator 120, a CCD 121, a driver 122, an amplifier 123, an A/D converter 124, a DRAM 125, an compression/expansion section 126, an image memory 127, a ROM 128, a RAM 129, a CPU 130, a key input section 131, a video signal generation section 132, a VRAM 133, a D/A converter 134, a color LCD 135, an amplifier 136, a CD (Character Generator) 137 and an I/O port 138.

The timing generator 120 generates a timing signal for controlling the driver 122 for driving the CCD 121. The driver 122 drives the CCD 121 in accordance with the timing signal from the timing generator 120. The CCD 121 photoelectrically converts a light signal representing an image formed by a lens unit 103a to an analog electric signal. The analog electric signal, to which the light signal has been photoelectrically converted by the CCD 121, is input to the A/D converter 124 through the amplifier 123.

The A/D converter 124 is a circuit for converting the analog electric signal output from the CCD 121 to digital image signals. The DRAM 125 temporarily stores the digital image signals to which the analog signal has been converted by the A/D converter 124. The compression/expansion section 126 compresses the digital image signals by an encoding process. The compression/expansion section 126 also performs the expansion of data by carrying out a decoding process with respect to the digital image signals. The image memory 127 includes a flash memory, for example, and stores the digital image signals compressed by the compression/expansion section 126. The image memory 127 can store digital image signals corresponding to images the number of which is 100 or less.

The video signal generation section 132 generates digital video signals by adding sync signals to the digital image signals. The VRAM 133 is a memory for storing the digital video signal. The D/A converter 134 converts the digital video signals output from the video signal generation section 132 to an analog video signal. The color LCD 135 drives the liquid crystal in accordance with the analog video signal input from the D/A converter 134 through the amplifier 136, and displays a photographic image.

The CG (Character Generator) 137 stores data, such as value data and cursor data, for causing image data stored in the image memory 127 to be displayed on the color LCD 135.

The ROM 128 stores programs for driving and controlling each part of the digital camera 101. The CPU 130 executes the programs stored in the ROM 128, and controls each part of the digital camera 101. The RAM 129



temporarily stores data used during arithmetic processing, etc. at the time the CPU 130 performs processing. In response to a key operation signal input from the key input section 131, the CPU 130 executes the programs stored in the ROM 128, using the RAM 129 as a work area. The key input section 131 5 has various keys arranged on the digital camera 101, as described previously. The I/O input port 138 is an interface which controls the input/output of image signals and/or the like converted to serial signals.

The operation of the digital camera 101 will now be described.

When the user depresses a shutter button 109, the timing generator 120 10 outputs a timing signal. In response to the timing signal output from the timing generator, the driver 122 drives the CCD 121 so as to photograph the external object to be photographed and fetch the image thereof formed by the lens unit 103A. The image data fetched into the CCD 121 is sent to the DRAM 125 through the amplifier 123 and the A/D converter 124, and is stored in the DRAM 15 125 as digital image signals. The CPU 130 performs the color arithmetic processing with respect to the digital image signals, and generates luminance signals and chrominance signals. The CPU 130 transfers the luminance and chrominance signals to the compression/expansion section 126. The compression/expansion section 126 compresses the transferred luminance and 20 chrominance signals, and stores them in the image memory 127.

In the case of reproducing the image data stored in the image memory 127, the user first moves the mode changing switch 106 downward so that the digital camera 101 is set in the playback mode (PL). When the digital camera is set in the playback mode, the compressed image signals (the compressed 25 luminance and chrominance signals) are transferred from the image memory 127 to the compression/expansion section 126. The digital image signals including the luminance and chrominance signals expanded by the compression/expansion section 126 are transferred to the video signal generation section 132. The video signal generation section 132 generates 30 digital video signals including the digital image signals and sync signals added thereto, and writes the video signals in the VRAM 133. The video signal generation section 132 outputs the written digital video signals to the color LCD 135 through the D/A converter 134 and the amplifier 136. The color LCD 135 displays the image corresponding to the image data stored in the image 35 memory 127.

The circuit blocks of the printer 115 shown in Fig. 8 will now be described.

The printer 115 has a CPU 140, an image memory 141, an expansion

section 142, a selection section 143, a key input section 144, an I/O port 145, a ROM 146, a color printer section 147 and a RAM 148, all being connected to each other via a bus 149.

The I/O port 145 includes a circuit having a serial communication function, and performs data transmission/reception to/from an external unit. In general, the I/O port 145 is incorporated in an LSI serving as an one chip processor CPU. The key input section 144 is connected to a general purpose port of the CPU 140, and outputs, to the CPU 140, key operation signals supplied from seven operation keys 118a to 118g. In response to the key operation signals, the CPU 140 executes programs stored in the ROM 146. The function of each operation signal will be described later.

The ROM 146 has a program area in which are stored programs for the operations of the CPU 140 which are, for example, the processing required for communication, the formation of print data, printing, the creation of a calendar, and an image data area in which data of compressed menus for selecting various format images and formats of the printer, such as compressed display data, compressed background data, bit map data corresponding to character codes, layout, mini labels and postcards, etc. are stored.

The selection section 143 selects image data to be displayed on the viewfinder 104, the programs (described later) stored in the ROM 146 and executed in response to the operation signals according to the operations of the operation keys 118a to 118g, the image data (the compressed display data and background data) and the CG (Character Generator), etc.

The expansion section 142 has an image expansion function such as the JPEG, and expands, for example, data of a background image stored in the ROM 146 and the data corresponding to a selected format image. The expansion section 142 expands data transferred from the digital camera 101. The image data stored in the ROM 146 and the image data representing a photographic image and output from the digital camera 101 are compressed data. Therefore, it is necessary to expand those compressed data to a predetermined size, to which end the expansion section 142 is needed.

The RAM 148 has a work area for the programs executed by the CPU 140 are stored, a print data memory area in which are stored Y print data for Yellow, M print data for Magenta and C print data for Cyan all being produced in accordance with a print data processing program in the ROM 146 after image data stored in the image memory 141 is expanded by the expansion section 142. an image combining area used to combine the print data and decoration data

such as the background data, and a memory area in which data set by the CPU 140 is stored, etc.

The color printer section 147 is a printer engine section, to which motor drivers for driving a DC motor, a stepping motor, etc., a print head and various  
5 sensors are connected. The sensors, which include an optical sensor, a mechanical contact type sensor and/or the like, sense the positions of Yellow (Y), Magenta (M) and Cyan (C) ink ribbons for color printing, and sense whether the printing sheet P has been loaded into the printer 115 through the sheet insertion/discharge slot 116.

10 Fig. 9 is a diagram showing how representative ones of the aforementioned drivers and sensors are connected to one another.

A head motor 150 is connected to the CPU 140 with a motor driver 150a therebetween. A ribbon motor 151 is connected to the CPU 140 with a motor driver 152a therebetween. A sheet feeding motor 152 is connected to the CPU  
15 140 with a motor driver 152a therebetween. The motor head 150 moves a print head 153 between a print position and a non-print position. When the print head 153 is moved to the print position, it presses the printing sheet with an ink ribbon inbetween. The ribbon motor 151 sequentially feeds the Yellow (Y), Magenta (M) and Cyan (C) ink ribbons between the print head and the  
20 printing sheet P. The printing sheet P is moved for each line in a subscanning direction by the sheet feeding motor 152.

The print head 153 connected to the CPU 140 includes nine hundred and sixty heating elements formed at a density of 300dpi (dots per inch) on a ceramic plate, and driver ICs for turning on/off the heating elements  
25 independently from each other. A sensor 154 senses that the printing sheet P has been loaded into the printer 115 through the sheet insertion/discharge slot 116.

Under the control of the CPU 140, the color printer section 147 turns on, for a predetermined period of time and at a print timing for each line, those of  
30 the heating elements which are located at the positions where dots are to be printed, such that a predetermined amount of heat is supplied to the ink ribbons, and the inks of predetermined colors are transferred onto the printing sheet, thus printing an image on the printing sheet.

The function of each of the keys provided on the printer 115 will now be  
35 described.

The "POWER" key 118d turns the printer 115 on/off. Moreover, the "POWER" key 118d includes a plurality of LEDs and indicates the internal

condition of the printer 115 by lighting the LEDs. For example, when the printer 115 is an ON state and is ready to perform printing, "green" one of the LEDs emits light. However, when the malfunction of a driving motor, sheet jamming, or an error such as mismatching between a printing sheet and an ink ribbon occurs, "red" one of the LED emits light. When the printer 115 is busy, "orange" one of the LEDs emits light. When the printer 115 is turned on upon the depression of the "POWER" key 118d, an initial menu "TOP-MENU" which will be described later is displayed on the viewfinder 104 of the digital camera 101.

10 When the "EASY" key 118e is depressed during the display of the "TOP-MENU", the operation mode of the printer 115 is switched to an "easy print mode", irrespective of the selection of a format. The "easy print mode" is one in which a reproduced image displayed on the viewfinder 104 of the digital camera 101 is printed as is.

15 The "MENU" key 118f has the function to cause the viewfinder 104 to display the "TOP-MENU". Therefore, the depression or input of the "MENU" key 118f while the viewfinder 104 is displaying the "TOP-MENU" is ineffective. The "BACK" key 118g has the function to switch the menu which is being currently displayed on the viewfinder 104 to the previous menu.

20 The "SET" key 118c is a determination key. By depressing the "SET" key 118c during the selection process, a format which has been selected in, for example, a menu displayed on the viewfinder 104, is determined as the format to be displayed.

The "-" key 118a and the "+" key 118b are ones used when selecting a format and switching menus from one to another. The "+" key 118b is that for moving the cursor a forward direction, while the "-" key 118a is that for moving the cursor in a reverse direction.

Fig. 10 shows how the initial menu is displayed on the viewfinder 104 of the digital camera 101 (hereinafter referred to simply as the camera 101) in the case where the camera 101 and the printer 115 are connected to each other as shown in Fig. 7.

In this case, the camera 101 is turned on by operating the power source switch 105 of the camera 101. The mode changing switch 106 is moved to "PL" in order to set the camera 101 in the image playback mode. When the printer 115 is turned on upon the depression of the "POWER" key 118d, the "TOP-MENU" shown in Fig. 10 is displayed on the viewfinder 104 of the camera 101. The "TOP-MENU" is used to select the desired one of the menus which

will be described later.

The display state of the viewfinder 104, which changes from the "TOP-MENU" in accordance with the depressing operations of the individual keys 118a to 118g on the printer 115, will now be explained.

5 As shown in Fig. 10, the letters "MENU" are displayed at the top on the "TOP-MENU", and six icons are displayed in two rows under the letters "MENU". The letters "LAYOUT" are shown under a first icon 155 (i.e. the left icon in the upper row). The letters "CALENDAR", "MINI", "POSTCARD", "COLLAGE" and "INDEX" are shown under icons 156, 157, 158, 159 and 160, respectively. A  
10 cursor 161 is displayed under the letters "LAYOUT" shown below the first icon 155. This indicates that the first "LAYOUT" icon 155 has been selected on the "TOP-MENU".

There are two types of cameras, one type being that the camera has the function of generating character data to be displayed on a menu, and the other  
15 type being that the camera does not have the above function. When the printer 115 is connected to the camera 101 with the communication cable 114, the printer 115 recognizes the type of the camera 101. When the camera 101 is of the former type that the camera itself can generate character data such as characters and a cursor, the character codes corresponding to the above-  
20 described letters and cursor, and data specifying their display positions (addresses) are transferred to the camera 101. The camera 101 generates image data (bit map data) representing the above-described letters and cursor, combines the generated image data with the "TOP-MENU" transferred as image data from the printer 115 and including the icons 155 to 160, and displays the  
25 combination thereof on the viewfinder 104. When the camera 101 is of the latter type, the printer 115 transfers image data representing the "TOP-MENU" including the icons 155 to 160 to the camera 101. Further, the printer 115 produces image data representing the letters and the cursor which have been stored in advance in the printer 115, and transfers those image data together  
30 with their addresses to the camera 101.

By depressing the "+" key 118b while the "TOP-MENU" is being displayed, the icon to be selected can be switched from one to another in the order of the icons 155, 156, 157, 158, 159 and 160. In this case, the cursor 166 moves to under the letters shown below the selected icon. By depressing the "-" key  
35 118a, the icon to be selected can be switched from one to another in the order opposite to that when the "+" key 118b is depressed. In this case also, the cursor 161 moves to under the letters shown below the selected icon. Thus.

upon the depression of the "+" key 118b or the "-" key 118a, one of the functions of the printer 115, such as the menu selecting function and the page switching function which will be described later, is selected, or alternatively, the camera 101 is controlled in function.

5 When the "MENU" key 118f is depressed, the mode of the camera 101 is shifted to a "TOP-MENU" display mode. Therefore, the depression or input of the "MENU" key 118f during the display of the "TOP-MENU" is ineffective.

There is the case where the depression or input of the "BACK" key 118g is ignored as being ineffective. If the "BACK" key 118g is depressed after each  
10 mode and each operation have been selected and determined, the depression or input of the "BACK" key 118g is accepted as being effective, when the prior selection and determination are canceled.

When the "EASY" key 118e is depressed during the display of the "TOP-MENU", the operation mode is switched to the "easy print mode" irrespective of  
15 the selection of an icon. In the "easy print mode", the reproduced image displayed on the viewfinder 104 of the digital camera 101 can be printed as is. It is also possible to divide the viewfinder 104 into a plurality of frames and to display a plurality of images on those frames. The operation of the printer 115 in the "easy print mode" is the basic operation. The "EASY" key 118e has the  
20 function of changing the number of reproduced images to be displayed at a time on the viewfinder 104 from 1 to 4, 4 to 9, and 9 to 1 in the "easy print mode".

The display of reproduced images, the number of which is changed from one to another in the "easy print mode", will now be described.

Figs. 11A to 11F show examples of images changed and displayed on the  
25 viewfinder 104 upon the depression of the "EASY" key 118e, "-" key 118a or the "+" key 118b in the "easy print mode".

As shown in Fig. 11A, when the "easy print mode" is set, the first recorded image (hereinafter referred to simply as the image) is displayed on the viewfinder 104. Upon the depression of the "+" key 118b, the first image which  
30 is being displayed on the viewfinder 104 is changed to the second image.

Each time the "+" key 118b is depressed, the display image is switched to the third image, the fourth image, et seq. up to the last recorded image. After the last image is displayed, the first image is displayed again. When the "-" key  
118a is depressed, the image which is being displayed is changed to the  
35 preceding image. When the "-" key 118a is depressed under the condition wherein the first image shown in Fig. 11a is being displayed, the first image is changed to the last image.

When the "EASY" key 118e is depressed during the display of the first image shown in Fig. 11A, the viewfinder 104 is divided into four frames, and the first to fourth images are displayed one on each of the four frames on the viewfinder 104. When the "+" key 118b is depressed while the first to fourth 5 images are being displayed on the viewfinder 104 as shown in Fig. 11B, the next four images, i.e., the fifth to eighth images are displayed on the viewfinder 104 as shown in Fig. 11E. Each time the "+" key 118b is depressed, the next four images are sequentially displayed. When the number of images to be displayed last is less than four, one or more frames with no images to be 10 displayed are displayed in gray.

When the "EASY" key 118e is depressed again while the four images shown in Fig. 11B are being displayed on the viewfinder 104, the viewfinder is divided into nine frames, and the first to ninth images are displayed one on each of the nine frames on the viewfinder 104. When the "+" key 118b is depressed 15 at that time, the next nine images, i.e., the tenth to eighteenth images are displayed on the viewfinder 104 as shown in Fig. 11F. Each time the "+" key 118b is depressed, the next nine images are sequentially displayed. When the number of images to be displayed last is less than nine, one or more frames with no images to be displayed are displayed in gray. When the "EASY" key 20 118e is depressed one more time while the nine images shown in Fig. 11C are being displayed on the viewfinder 104, the state of the display returns to that shown in Fig. 11A.

Thus, upon the depression of the "EASY" key 118e, the number of image display frames on the viewfinder 104 is changed from 1 to 4, 4 to 9, and 9 to 1. 25 When the "+" key 118b is depressed, the image (images) which is being currently displayed on the viewfinder 104 is changed to the next image (images) without the number of frames being changed. When the "-" key 118a is depressed, the image (images) which is being currently displayed on the viewfinder 104 is changed to the preceding image (images) without the number 30 of frames being changed. When the printing sheet P is loaded through the sheet insertion/discharge slot 116 (shown in Fig. 7) under the condition wherein the desired image (images) is being displayed on the viewfinder 104, the desired image (images) is printed.

Figs. 12A to 12C show examples of images changed and displayed on the 35 viewfinder 104 upon the depression of the "EASY" key 118e in the "easy print mode". Fig. 12A shows the state wherein the third image is displayed on the viewfinder 104 as a result of the "+" key 118b being depressed during the

display of the image shown in Fig. 11D. When the "EASY" key 18e is depressed under the condition wherein the image shown in Fig. 12A is being displayed, the third to sixth images are displayed on the viewfinder 104. When the "EASY" key 118e is depressed again under that condition, the third to 5 eleventh images are displayed on the viewfinder 104 as shown in Fig. 12C. When the "EASY" key 118e is depressed one more time under the condition shown in Fig. 12C, the state of the display returns to that shown in Fig. 12A.

Figs. 13A to 13E shows examples of images changed and displayed on the viewfinder 104 upon the depression of the "-" key 118a or the "+" key 118b 10 in the "easy print mode". Fig. 13C illustrates the same display state as that shown in Fig. 12B. Let it be assumed that in the case of the examples shown in Figs. 13A to 13E, the number of recorded images stored in the image memory 127 is nine.

When the "+" key 118b is depressed under the condition wherein the 15 images shown in Fig. 13C are being displayed, the images (the seventh and subsequent images) following the sixth image which is the last one among the images shown in Fig. 13C are displayed on the viewfinder 104 as shown in Fig. 13D. Since the number of recorded images is nine, the last frame (marked with "x" in Fig. 13D) with no image to be displayed is displayed in gray. When 20 the "+" key 118b is depressed again during the display of the images shown in Fig. 13D, since there is no image having a greater photograph number than No. 9, the first to fourth images are displayed on the viewfinder 104 as shown in Fig. 13E. With key operations thereafter, the images to be displayed on the viewfinder 104 are changed, based on Fig. 13E, not Fig. 13C. To be specific, 25 when the "+" key 118b is depressed under the condition wherein the images shown in Fig. 13E are being displayed, four images (the fifth to eighth images) following the last display image (the fourth image) are displayed on the viewfinder 104, although a diagram showing such a state is not presented.

When the "-" key 118a is depressed under the condition wherein the 30 images shown in Fig. 13C are being displayed, since only the first and second images precede the third image which is the first one among the images shown in Fig. 13C, the first to fourth images are displayed on the viewfinder 104 as shown in Fig. 13B. With key operations thereafter, the images to be displayed on the viewfinder 104 are changed, based on Fig. 13B, not Fig. 13C. To be 35 specific, when the "-" key 118a is depressed one more time under the condition wherein the images are being displayed as shown in Fig. 13B, the last ninth image is displayed on the first one of four frames as shown in Fig. 13A, and the



remaining three frames are displayed in gray (as marked with "x"). When the "-" key 118a is depressed one more time under the condition wherein the image is being displayed as shown in Fig. 13A, four images (the fifth to eighth images) preceding the last image (the ninth image) are displayed on the viewfinder 104, 5 although a diagram showing such a state is not presented.

Figs. 14A to 14E show examples of images changed and displayed on the viewfinder 104 upon the depression of the "-" key 118a or the "+" key 118b in the "easy print mode". Fig. 14C shows the same display state as that shown in Fig. 12C. Let it be assumed that in the examples shown in Figs. 14A to 14E, 10 the number of recorded images stored in the image memory 127 is fifteen.

When the "-" key 118a is depressed under the condition wherein the images shown in Fig. 14C are being displayed, since only the first and second images precede the third image which is the first one among the images shown in Fig. 14C, the first to ninth images are displayed on the viewfinder 104 as 15 shown in Fig. 14B. With key operations thereafter, the images to be displayed on the viewfinder 104 are changed, based on Fig. 14B, not Fig. 14C. To be specific, when the "-" key 118a is depressed one more time while the images are being displayed as shown in Fig. 14B, the tenth to fifteenth images are displayed on the first six ones of the nine frames shown in Fig. 14A, and the 20 remaining three frames are displayed in gray (as marked with "x"). When the "-" key 118a is depressed one more time under the condition wherein the images are being displayed as shown in Fig. 14A, nine images (the first to ninth images) preceding the first image (the tenth image) among the images shown in Fig. 14A are displayed on the viewfinder 104, although a diagram showing such 25 a state is not presented.

When the "+" key 118b is depressed under the condition wherein the images shown in Fig. 14C are being displayed, the images (the twelfth and subsequent images) following the eleventh image which is the last one among the images shown in Fig. 14C are displayed on the viewfinder 104 as shown in 30 Fig. 14D. Since the number of recorded images is fifteen, the last five frames (marked with "x" in Fig. 14D) with no images to be displayed are displayed in gray. When the "+" key 118b is depressed again during the display of the images shown in Fig. 14D, since there is no image having a greater photograph number than No.15, the first to ninth images are displayed on the viewfinder 104 35 as shown in Fig. 14E. With key operations thereafter, the images to be displayed on the viewfinder 104 are changed, based on Fig. 14E, not Fig. 14C. To be specific, when the "+" key 118b is depressed under the condition wherein

the images shown in Fig. 14E are being displayed, nine images (the tenth to eighteenth images) following the last display image (the ninth image) are displayed on the viewfinder 104 (in fact, however, the tenth to fifteenth images are displayed, because the number of recorded images as stored is fifteen),  
5 although a diagram showing such a state is not presented.

In the "easy print mode", the images to be displayed on the viewfinder 104 are changed by operating the "EASY" key 118e, the "-" key 118a or the "+" key 118b. When the "SET" key 118c is depressed during the display of a menu, that menu is determined as the desired one, and the operation mode of the  
10 printer 115 is shifted to the print mode. When the printing sheet P is loaded through the sheet insertion/discharge slot 116, the image which is being displayed on the viewfinder 104 of the camera 101 is printed as is.

The "EASY" key 118e can be used not only to print as described above the image on the viewfinder 104 as is, but also to select and determine the  
15 desired 1-frame image. For example, in the case where a hundred images as recorded are stored in the image memory 127, if the images are displayed one by one on the viewfinder 104 in order to search for a given image, the "+" key 118b has to be operated ninety-nine times or less, resulting in a long period of time being required. However, in the case of displaying nine images at a time  
20 as shown in Fig. 11C and depressing the "+" key 118b, all images can be sequentially displayed on the viewfinder 104 by operating the key twelve times at most. By depressing the "EASY" key 118e at the time nine images including the desired image are displayed on the viewfinder 104, the first image among the nine images is displayed alone on the viewfinder 104. If the "+" key  
25 118b is depressed eight times at most, the desired image will be displayed on the viewfinder 104. By depressing the "SET" key 118c at the time the desired image is displayed on the viewfinder 104, the image as displayed is determined as one to be printed.

Six printing menus selected and determined by the "LAYOUT" icon 155,  
30 the "CALENDAR" icon 156, the "MINI" icon 157, the "POATCARD" icon 158, the "COLLAGE" icon 159 and the "INDEX" icon 160 on the "TOP-MENU" shown in Fig. 10 will now be explained.

A layout/background printing menu selected and determined by the  
"LAYOUT" icon 155 is one for executing the function to print a background. In  
35 the case where the "LAYOUT" icon 155 is selected, an image which is the combination of the image as determined as above and a background can be printed. A calendar printing menu selected and determined by the

"CALENDAR" icon 156 is one for executing the function to print a calendar. In the case where the "CALENDAR" icon 156 is selected, a desk calendar with an image can be printed. A mini label printing menu selected and determined by the "MINI" icon 157 is one for executing the function to print mini labels. When 5 the "MINI" icon 157 is selected, sixteen images of the same pattern, which can be stuck as small-sized labels on corners of visiting cards and the like, can be printed together with a given one of the decoration patterns. A postcard printing menu selected and determined by the "POSTCARD" icon 158 is one for executing the function to print a postcard. When the "POSTCARD" icon 158 is 10 selected, a postcard with an image can be printed. An illustration combined printing menu selected and determined by the "COLLAGE" icon 159 is one for executing the function to perform illustration combined printing. When the "COLLAGE" icon 159 is selected, an image which is the combination of the determined image and a decoration frame can be printed. A menu selected 15 and determined by the "INDEX" icon 160 is one for executing the function to print an index. When the "INDEX" icon 160 is selected, all of the images recorded in the camera 101 can be printed in the form of an index.

The desired one of the above printing functions can be designated by depressing the "-" key 118a or the "+" key 118b so that the cursor is located 20 under the letters shown below the desired icon and by depressing the "SET" key 118c.

Fig. 15A shows the first page of a layout/background printing menu which is displayed when the "LAYOUT" icon 155 is selected and designated on the "TOP-MENU". Icons No.1 to No.6 showing six types of image layout forms are 25 displayed on the first page. A cursor (not shown) is displayed under icon No. 1 on the first page. Of the six icons, icon No. 1 shows the layout form in which a single lateral-frame image is laid out, icon No. 2 shows the layout form in which lateral-frame images are laid out so as to overlap one another, icon No. 3 shows the layout form in which vertical-frame images are laid out so as to overlap one 30 another, icon No. 4 shows the layout form in which two small and large lateral-frame images are laid out diagonally one above the other, icon No. 5 shows the layout form in which two vertical-frame images are laid out side by side, and icon No. 6 shows the layout form in which two lateral-frame images are aligned lengthwise. In this case also, the title "LAYOUT 1/3", the numbers "No. 1" to 35 "No. 6" of the icons and the cursor are transferred in the form of character codes from the printer 115 to the camera 101 when that camera has the function of displaying characters and the cursor. When the camera 101 does not have

the function of displaying characters and the cursor, bit map data stored in advance is transferred from the printer 115 to the camera 101.

Each time the "+" key 118b, for example, is depressed, the cursor is moved from icon No. 2 toward No. 6, thus selecting any one of the icons.

5 When the "+" key 118 is depressed under the condition wherein icon No. 6 is select, the page shown in Fig. 15B is displayed, and the cursor is displayed under icon No. 7 which is the first one among the icons illustrated in Fig. 15B. Icon No. 7 shows the layout form in which three lateral-frame images are laid out triangularly. Icon No. 12 shows the layout form in which four lateral-frame  
10 images are laid out in a matrix pattern so that each adjacent pair of lateral-frame images are in contact with each other. When the "+" key 118b is depressed under the condition wherein icon No. 12, which is the last one among the icons illustrated in Fig. 15B, is select, the page shown in Fig. 15C is displayed, and the cursor is displayed under icon No. 13 which is the first one among the icons  
15 illustrated in Fig. 15C.

Icon No. 13 also shows the layout form in which four lateral-frame images are laid out in a matrix pattern. However, each adjacent pair of lateral-frame images in icon No. 13 are not in contact with each other, and are spaced at a predetermined interval from each other. Icon No. 17 shows the layout form in  
20 which nine lateral-frame images are laid out in a matrix form so that each adjacent pair of images are in contact with each other. Icon No. 18 shows the layout form in which nine lateral-frame images are laid out so that each adjacent pair of images are spaced at a predetermined interval from each other. When "+" key 118b is depressed under the condition wherein icon No. 18 is select, the  
25 page shown in Fig. 15A is displayed again. The printer 115 has eighteen image layout forms shown in Figs. 15A to 15C. The direction in which the cursor is moved by depressing the "-" key 118a is opposite to that when the cursor is moved by depressing the "+" key 118b.

In the case of the layout forms shown by icons Nos. 1, 2, 3, 12 and 17,  
30 backgrounds which will be described later cannot be determined. In the case of the layout forms shown by the other icons, the backgrounds can be determined.

When one of the icons showing the above-described layout forms is selected by depressing the "+" key 118b or the "-" key 118a and when the  
35 selected icon is determined as the desired icon by depressing the "SET" key 118c, the first page of a background selection menu for selecting the backgrounds of images to be laid out in the above-described layout forms is

displayed, except the case where the layout forms shown by icons Nos. 1, 2, 3, 12 and 17 are designated.

In Fig. 16, four pages for the selection of the backgrounds to be combined with the image(s) in the layout form represented by the selected layout icon are 5 illustrated overlapping one another. As shown in Fig. 16, six shrunk image icons showing background patterns are displayed on each of the above-described four pages, and those four pages with twenty-four icons are displayed sequentially. One of the background patterns shown by the twenty-  
10 with the image(s). The method of moving the cursor for selecting one of the icons showing the background patterns and the method of determining the icon indicated by the cursor as the icon showing the background to be combined with the image(s) are the same as those in the case of Figs. 15A to 15C. After the determination of the background, that background is combined with the  
15 image(s). This operation is repeated as for the other images in the layout shown by the selected layout icon, after which a printing sheet is loaded in order to start printing.

Fig. 17 shows the first page of a calendar printing menu which is displayed when the "CALENDAR" icon 156 is selected and determined on the  
20 "TOP-MENU". In the calendar print mode set in the case where the "CALENDAR" icon 156 is selected and designated, calendars of four formats can be printed. Icon No. 1 on the first page illustrated in Fig. 17 represents the calendar print format in which a calendar is superimposed on the right half of a lateral-frame image. Fig. 18A shows an example of a calendar printed when  
25 icon No. 1 is selected and determined. Icon No. 2 on the page illustrated in Fig. 17 represents the calendar print format in which a vertical-frame image is laid out on the left area, while a calendar is laid out on the right area. Fig. 18B shows an example of a calendar printed when icon No. 2 is selected and determined. Icon No. 3 on the page illustrated in Fig. 17 represents the  
30 calendar print format in which a calendar is laid out under a lateral-frame image. Fig. 18C shows an example of a calendar printed when icon No. 3 is selected and determined. Icon No. 4 on the page illustrated in Fig. 17 represents the calendar print format in which a calendar is laid out under the left lateral-frame image, while the next-month calendar is laid out above the right lateral-frame  
35 image. The method of selecting and determining one of the above-described icons on the first page of the calendar menu and an image fetching method are the same as those in the case where one icon on another menu explained

previously is selected and determined, after which an image/images is/are selected, determined and fetched.

In Fig. 19A, the first and second pages of a mini label printing menu which are displayed when the "MINI" icon 157 is selected and determined on the 5 "TOP-MENU" are illustrated overlapping each other. As shown in Fig. 19A, six icons showing image decoration patterns are displayed on each of the first and second pages. One icon can be selected among the twelve icons (image decoration patterns) on the first and second pages. The method of moving the cursor on the first and second pages and the method of selecting and 10 determining the icon indicated by the cursor as the desired one are the same as those explained with reference to Figs. 15A to 15C. After one of the image decoration patterns is determined as the desired pattern, a given image is selected and determined as the desired one in the manner explained previously. Then, as shown in Fig. 19B, sixteen images of the same pattern (normally the 15 photographs of a face in this case), which can be stuck as small-sized labels on corners of visiting cards, are displayed together with the selected decoration pattern on the viewfinder 104. When the printing sheet P is thereafter loaded through the sheet insertion/discharge slot 116 into the printer 115, printing is initiated. It is also possible to print sixteen photographs of a face as images 20 without such a decoration pattern.

In Fig. 20A, the first and second pages of a postcard printing menu which are displayed when the "POSTCARD" icon 158 is selected on the "TOP-MENU" are illustrated overlapping each other. Four icons showing patterns which stand for various festivals are displayed on each of the first and second pages. 25 One pattern can be selected among the eight patterns shown by the icons on the first and second pages. The method of moving the cursor on the first and second pages and the method of selecting and determining the icon indicated by the cursor are the same as those explained with reference to Figs. 15A to 15C. After the determination of the pattern, the desired image is selected and 30 determined as explained previously. Then, the selected pattern and the desired image laid out on a plain central part of the selected pattern are displayed as a composite image on the viewfinder 104. When the printing sheet P is thereafter loaded in the printer 115 through the sheet insertion/discharge slot 116, printing is initiated.

35 Fig. 20B shows the first page of an illustration combined printing menu which is displayed when the "COLLAGE" icon 159 is selected and determined on the "TOP-MENU". As illustrated in Fig. 20B, four image icons showing the

patterns of decoration frames are displayed on the first page. When icon No. 1 is selected, a designated image is fitted in the decoration frame with a flower pattern. When icon No. 2 is selected, three images designated are fitted in three frames like those of a film. When icon No. 3 is selected, an image like a poster, which is the combination of a designated image, the decoration letters "Cute" laid out on the left side of the image and a decoration laid out above the image, is printed. When icon No. 4 is selected and a photograph which is appropriate for use as a mug shot is designated, the photograph is laid out in a decoration frame having an upper part with the letters "WANTED", and an image like a poster used to search for a criminal in a Western film is printed.

Figs. 21A to 21C exemplify how recorded images are displayed on the viewfinder 104 when the "INDEX" icon 160 is selected and designated. Fig. 21A shows an example of the display when the number of images as recorded is four or less, in which case all of the recorded images are automatically displayed on the viewfinder 104. Fig. 21B shows an example of the display when the number of recorded images is five to nine, in which case all of the recorded images are automatically displayed on the viewfinder 104. Fig. 21C shows an example of the display when the number of recorded images is ten or greater, in which case all of the recorded images are displayed in a 10 × 10 matrix pattern on the viewfinder 104. In order to display 10 × 10 images in this manner, thumbnail image data (1 image is formed of 36 dots × 52 dots) is used.

The operation of the printer 115 having the above-described structure and functions will now be described with reference to the flowcharts shown in Figs. 22 to 30 and the examples of the display which are shown in Figs. 24A to 24C and Figs. 25A to 25C.

The processes shown in Figs. 22 to 30 are performed with each section of the printer 115 and each section of the digital camera 101 being controlled by the CPU 140 of the printer 115. When the digital camera 101 and the printer 115 are turned on under the condition wherein the communication terminal 113 of the digital camera 101 and the communication terminal 119 of the printer are connected with the communication cable 114, the image displaying and printing processes in the general flowchart illustrated in Fig. 22 start.

When the processes in the general flowchart shown in Fig. 22 start, it is determined whether a connection signal has been input from the digital camera 101 (step S1). When it is determined that no connection signal has been input from the digital camera 101 (when the result of the determination in the step S1 is "No"), the determination is repeated until a connection signal is input from the

digital camera 101.

When it is determined that a connection signal is input from the digital camera 101 (when the result of the determination in the step S1 is "Yes"), the type of the digital camera 101 is confirmed based on the connection signal (step 5 S2). In this step, based on a signal representing an ID number and output from the digital camera 101, it is determined whether or not the digital camera is of the type having the function to display characters on the viewfinder (the function to generate character image data).

As shown in Fig. 10, the "TOP-MENU" is displayed on the viewfinder 104 10 of the digital camera 101 (step S3). In this step, data for the display of the "TOP-MENU" is read out from a predetermined address in a compressed display data area of the ROM 146, and is transferred to the digital camera 101. Further, in accordance with the camera type as recognized, the letters 15 representing a title and those to be laid out under the respective icons are transferred to the digital camera 101 in the form of character codes or bit map data to which display addresses have been added. When the "TOP-MENU" is displayed on the viewfinder 104, it is determined whether any one of the keys of the key input section 144 has been depressed (step S4). Until any one of the keys is depressed, the determination step S4 is repeated.

20 When it is determined that the "MENU" key 118f or the "BACK" key 118g has been depressed, the determination step S4 is repeated. In other words, the depression of the "MENU" key 118f or the "BACK" key 118g is ignored.

When it is determined in the step S4 that the "EASY" key 118e has been depressed, the printer is placed in the "easy print mode" such that the "EASY" 25 process is initiated (step S5). In the "EASY" process, a command signal for causing the first image among the images stored in the image memory 127 to be displayed is output to the digital camera 101 (step S6). In response to this signal, the first one of the images stored in the image memory 127 is read out on the viewfinder 104 as shown in Fig. 11A, for example.

30 When the first image is displayed on the viewfinder 104, it is again determined whether any one of the keys of the key input section 144 has been depressed (step S7). Until any one of the keys is depressed, the determination step S7 is repeated. When it is determined in the step S7 that the "MENU" key 118f has been depressed, a return to the step S3 is performed. 35 When it is determined in the step S7 that the "BACK" key 118g has been depressed, the step S7 is repeated. In short, the depression of the "BACK" key 118g is ignored.



When it is determined in the step S7 that the "EASY" key 118e has been depressed, a command to display a plurality of images on the viewfinder 104 is output to the digital camera 101 (step S8). In response to this command, the first to fourth images are displayed on the viewfinder 104 as shown in Fig. 11B, 5 due to the plural image display function of the digital camera 101.

After the images have been displayed, a return to the step S7 is performed, and the depression of any one of the keys of the key input section 144 is waited for. When it is determined that the "EASY" key 118e has been depressed again, the command to display a plurality of images is output again 10 to the digital camera 101 in the step S8. As the "EASY" key 118e is depressed for the third time, the fourth time, et seq., the image display changes in sequence as shown in Figs. 11C, 11A and 11B, for example, or as shown in Figs. 12A, 12B and 12C.

When it is determined in the step S7 that the "+" key 118b or the "-" key 15 118a has been depressed, the command "Go To Next/Previous Image" is output to the digital camera 101 (step S9). After that command has been output to the digital camera 101, a return to the step S7 is performed, and the depression of any one of the keys of the key input section 144 is waited for. In the digital camera 101, in response to the above command, the image (images) which is 20 being displayed on the viewfinder 104 is changed from one having a given photograph number to another having the subsequent/preceding photograph number. For example, in the case where the image having photograph No. 1 (No. 2) is being currently displayed on the viewfinder 104 as shown in Fig. 11A (11D), it is changed to the image having photograph No. 2 (No. 1) as shown in 25 Fig. 11D (11A). In the case where the images having photograph Nos. 1 to 4 (Nos. 5 to 8) are being currently displayed on the viewfinder 104 as shown in Fig. 11B (11E), they are changed to the images having photograph Nos. 5 to 8 (Nos. 1 to 4), as shown in Fig. 11E (11B).

When it is determined in the step S7 that the "SET" key 118c has been 30 depressed during the display of any desired image in the steps S6 to S9, the image(s) to be printed is determined (step S10). In this step, the CPU 140 of the printer 115 outputs a command signal for causing the digital image data corresponding to the image displayed on the viewfinder 104 to be transferred to the printer 115. In response to this command signal, the CPU 130 of the digital 35 camera 101 reads the image data corresponding to the displayed image from the image memory 127, and transfers the image data to the printer 115 through the I/O port 138 and the communication cable 144.

The number of pixels of the CCD 121 in the digital camera 101 connected to the printer 115 may be 250,000, 300,000 or 350,000, for example. The printer 115 prints an image at 480 dots in the main scanning direction and at 640 dots in the subscanning direction. In other words, the number of dots 5 printed by the printer 115 is  $480 \times 640 = 307,200$  dots (about 300,000 dots). It is most preferred that the image data to be transferred from the digital camera 101 to the printer 115 be data of such a resolution that the printer 115 can print a received image without changing the number of dots (resolution) of the image. When the number of pixels of the CCD 121 in the digital camera 101 connected 10 to the printer 115 is 250,000, the digital camera 101 converts data of 250,000 pixels to that of about 300,000 dots which is equal to the number of dots printed by the printer 115. That is, the digital camera 101 interpolates the pixels of the image data, and thereafter sends the image data to the printer 115. When the number of pixels of the CCD 121 of the digital camera 101 connected to the 15 printer 115 is 350,000, the digital camera 101 converts data of 350,000 pixels to that of about 300,000 dots which is equal to the number of dots printed by the printer 115. That is, the digital camera 101 thins out the pixels of the image data, and thereafter sends the image data to the printer 115. When the number of dots printed by the printer 115 is not  $480 \times 640 = 307,200$  dots (about 20 300,000 dots), the digital camera 101 needs only change the resolution of the image data to that according to the number of pixels printed by the printer 115 and send the image data to the printer 115.

The printer 115 temporarily stores the compressed image data as transferred in the image memory 141. The compressed image data stored in 25 the image memory 141 is expanded by the expansion section 142, after which Y print data for yellow, M print data for magenta, and C print data for cyan are produced in accordance with the print data processing program stored in the ROM 146. The print data as produced are stored in the print data memory area of the RAM 148 in the form of a bit map pattern. The Y print data, the M 30 print data and the C print data may be stored in three memory areas in the RAM 148. However, it is also possible to sequentially store the Y print data, the M print data and the C print data in the same memory area and to sequentially print those data.

When the print data are stored in the print data memory area, the printer 35 115 performs the printing process (step S11). The printing process will now be described with reference to the flowchart shown in Fig. 23.

After the start of the printing process in the flowchart shown in Fig. 23, it is

first determined whether the sensor 154 has sensed the loading of the printing sheet P through the sheet insertion/discharge slot 116 (step S21). If the printing sheet P has not yet been loaded (the result of the determination in the step S21 is "No"), it is determined whether any one of the keys of the key input section 144 has been depressed (step S22). When it is determined that none of the keys of the key input section 144 has been depressed (the result of the determination in the step S22 is "No"), a return to the step S21 is performed. Then, the determination steps S21 and S22 are repeated.

When it is determined that the sensor 154 has sensed the loading of the printing sheet P (the result of the determination in the step S21 is "Yes"), the printing process is executed (step S23). In the printing process, based on the print data stored in the print data memory area (not shown) of the RAM 148, the CPU 140 outputs, to the print head 153, heat generation control data for each color and for each main scanning line in proportion to the gradation of the image to be printed. The CPU 140 causes the motor drivers 150a and 150b to drive the head motor 150 and the ribbon motor 151 in synchronization with the output of the heat generation control data. Then, the CPU 140 causes the motor driver 152a to drive the sheet feeding motor 152. Then, the image corresponding to the image data determined in the step S10 is thermally printed on the printing sheet P in the "easy print mode" described in relation to Figs. 11 to 14. When the print of the image is finished, the printing sheet P is discharged through the sheet insertion/discharge slot 116.

It is next determined whether the sensor 154 has sensed the discharge of the printing sheet P through the sheet insertion/discharge slot 116 (step S24). When it is determined that the print of the image has ended (the result of the determination in the step S24 is "Yes"), a return to the step S21 is performed, and the determination steps S21 and S22 are repeated.

When it is determined in the step S22 that one of the keys of the key input section 144 has been depressed (the result of the determination in the step S22 is "Yes"), the processing according to the key depression is initiated. In other words, the print processing mode can be changed to another processing mode not only after the print of the image is finished, but also before the print of the image is initiated, by depressing one of the keys 118a to 118g of the key input section 144.

When it is determined in the step S22 that one of the keys of the key input section 144 has been depressed, it is determined whether the depressed key is the "BACK" key 118g (step S25). When it is determined that the depressed

key is the "BACK" key 118g, a command signal for causing the previously reproduced image to be displayed on the viewfinder 104 is output to the digital camera 101 through the communication cable 114 (step S26). After the output of the command signal, a return to the step S7 shown in Fig. 22 is performed.

5 Consequently, the image which is being displayed on the viewfinder 104 of the digital camera 101 is changed to the image displayed previously, and the next key depression is waited for.

When it is determined in the step S25 that the depressed key is not the "BACK" key 118g (the result of the determination in the step S25 is "No"), it is  
10 determined whether the "MENU" key 118f has been depressed in the step S22 (step S27). When it is determined that the "MENU" key 118f has been depressed (the result of the determination in the step S27 is "Yes"), a return to the step S3 shown in Fig. 22 is performed. Then, the "TOP-MENU" illustrated in Fig. 10 is displayed again on the viewfinder 104 of the digital camera 101 so  
15 that another processing shown in the "TOP-MENU" can be applied to the image selected and determined as the image to be printed.

When it is determined in the step S27 that the "MENU" key 118f has not been depressed in the step S22 (the result of the determination in the step S27 is "No"), it is determined whether the "EASY" key 118e has been depressed in  
20 the step S22 (step S28). When it is determined that the "EASY" key 118e has not been depressed (the result of the determination in the step S28 is "Yes"), a return to the step S8 is performed. Then, the "EASY" process is restarted.

When it is determined that the none of the "BACK" key 118g, the "MENU" key 118f and the "EASY" key 118e has been depressed in the step S22, the  
25 determination steps S21 and S22 are repeated. In short, during the printing process in the flowchart shown in Fig. 23, the depressions of keys other than "BACK" key 118g, the "MENU" key 118f and the "EASY" key 118e are ignored.

Referring to Fig. 22 again, when it is determined in the step S4 that the "+" key 118b or the "-" key 18a has been depressed, the cursor moving process is  
30 conducted (step S12), and a return to the step S4 is performed. In the cursor moving process of the step S12, in accordance with the position of the cursor which is being currently displayed and the depression of the "+" key 118b or the "-" key 18a, the address of the new display position of the cursor and cursor display data are sent to the digital camera 101, and data for causing the  
35 position in which the cursor has been located to be displayed in white is sent to the digital camera 101.

When it is determined in the step S4 that the "SET" key 118c has been

depressed, the mode of the printer is shifted to that one of various printing process modes which is indicated by the icon selected by the cursor (step S13). Then, one of the layout/background printing process, the calendar printing process, the card (postcard) printing process, the mini label printing process, 5 the illustration combined (collage) printing process and the image list (index) printing process is executed.

The digital camera 101 executes an image display process required to display the images stored in the image memory 27 and image display processes required to display the menus. In the image display processes required to 10 display the menus, the image data to be displayed is transferred from the printer 115 to the digital camera 101 through the communication cable 114, and a menu is displayed on the viewfinder 104.

Fig. 24 is a flowchart showing the layout/background printing process, Fig. 27 is a flowchart showing the calendar printing process, Fig. 28 is a flowchart 15 showing the mini label printing process, Fig. 29 is a flowchart showing the card (postcard) printing process, and Fig. 30 is a flowchart showing the image list (index) printing process. The illustration combined printing process (the collage printing process) is substantially the same as the card (postcard) printing process, and therefore its flowchart and explanation will not be 20 presented.

The layout/background printing process in the flowchart of Fig. 24 will now be described.

In the flowchart shown in Fig. 24, the first page of a layout selection menu which is shown in Fig. 15A is first displayed on the viewfinder 104 (step S31). 25 When the layout selection menu is displayed on the viewfinder 104, it is determined whether any one of the keys of the key input section 144 has been depressed (step S32). When it is determined that none of the keys of the key input section 144 has been depressed (the result of the determination in the step S32 is "No"), the determination step S32 is repeated, and the depression of 30 any one of the keys of the key input section 144 is waited for.

When it is determined in the step S32 that the "EASY" key 118e has been depressed, the step S8 of Fig. 22 is performed. When it is determined in the step S32 that the "MENU" key 118f has been depressed, the step S3 of Fig. 22 is performed. When it is determined in the step S32 that the "+" key 118b or 35 the "-" key 118a has been depressed, the cursor is moved in the same manner as in the case of the step S12 (step S35). Thereafter, returning to the step S32, the next key depression is waited for. The depression of the "+" key 118b is

repeated in the steps S32 and S35, the second and third pages of the layout selection menu which are illustrated in Fig. 15B and 15C, respectively, are displayed sequentially on the viewfinder 104.

When it is determined in the step S32 that the "BACK" key 118g has been  
5 depressed, it is determined whether the first page of the layout selection menu which is illustrated in Fig. 15A is being displayed on the viewfinder 104 (step S33). When it is determined that the first page of the layout selection menu which is illustrated in Fig. 15A is being displayed (the result of the determination in the step S33 is "Yes"), a shift to the step S3 is performed. In other words,  
10 the preceding menu is displayed. When it is determined that the second page shown in Figs. 15B or the third page shown in Fig. 15C is being displayed, the page preceding that which is being displayed is displayed on the viewfinder 104 (step S34). After this, a return to the step S32 is performed. By performing such processing, one of eighteen icons displayed on those pages of the layout  
15 selection menu which are illustrated in Figs. 15A to 15C can be selected, and the image layout form in which images are to be printed can be determined.

When it is determined in the step S32 that the "SET" key 118c has been depressed, under the condition wherein one of the eighteen icons is select, the layout form represented by the icon indicated by the cursor is determined as the  
20 desired layout form, and is stored in the RAM 148 (step S36). Following this, it is determined whether the layout form as determined shows a layout with a background (step S37).

When it is determined in the step S37 that the layout form shows a layout with a background (the result of the determination in the step S37 is "Yes"), the  
25 background selection menu is displayed on the viewfinder 104 (step S38), and it is determined whether any one of the keys of the key input section 144 has been depressed (step S39). A key input from the key input section 144 is waited for until it is determined that any one of the keys of the key input section 144 has been depressed. The menu (the background selection menu)  
30 displayed in the step S38 has pages with the background icons shown in Fig. 16.

When it is determined in the step S39 that the "EASY" key 118e has been depressed, a shift to the step S8 is performed. When it is determined in the step S39 that the "MENU" key 118f has been depressed, a shift to the step S3 is  
35 performed. When it is determined in the step S39 that the "+" key 118b or the "-" key 118a has been depressed, the cursor is moved (step S42), and a return to the step S39 is performed. The cursor moving operation in the step S42 is

the same as that in the step S35.

When it is determined in the step S39 that the "BACK" key 118g has been depressed, it is determined whether the first page of the background selection menu which is illustrated in Fig. 16 is being displayed on the viewfinder 104 (step S40). When it is determined that the first page of the background selection menu is being displayed (the result of the determination in the step S40 is "Yes"), a return to the step S31 is performed. In other words, the first page of the preceding menu is displayed. When it is determined that one of the second and fourth pages of the background selection menu which are shown in Fig. 16 is being displayed (the result of the determination in the step S40 is "No"), the page preceding one which is being displayed is displayed on the viewfinder 104 (step S41), and a return to the step S39 is performed. In the above manner, the desired one of twenty four icons on the four pages of the background selection menu which are illustrated in Figs. 16 can be selected.

When it is determined in the step S39 that the "SET" key 118c has been depressed, under the condition wherein one of backgrounds is selected thus, the background represented by the background icon indicated by the cursor is determined as the desired background, and the background data is stored in the RAM 148 (step S43).

When it is determined in the step S37 that the layout form as selected does not show a layout with a background, the background selecting process from the step S38 to the step S43 is not performed, and the step S44 is performed.

The image selecting process (step S44) and the image direction setting process (step S45), which will be described below in detail, are conducted next. When a layout form for a plurality of images is selected, the background selecting process, the image selecting process and the image direction setting process are performed with respect to the images in the sequence from the first one of those images.

The image selecting process in the step S44 will now be described in detail, with reference to the flowchart shown in Fig. 25.

When the process in this flowchart starts, an image is first displayed on the viewfinder 104 (step S51). More specifically, as shown in Fig. 11A, the image having photograph No. 1 and stored in the digital camera 101 is displayed (alone) on the viewfinder 104.

When the image selection menu is displayed, it is determined whether any one of the keys of the key input section 144 has been depressed (step S52).

A key input from the key input section 144 is waited for until it is determined that any one of the keys of the key input section 144 has been depressed. When it is determined in the step S52 that the "MENU" key 118f has been depressed, a shift to the step S3 is performed, and the "TOP-MENU" is displayed on the  
5 viewfinder 104. When it is determined in the step S52 that the "BACK" key 118g has been depressed, a return to the step S38 is performed, and the background selection menu shown in Fig. 16 is displayed on the viewfinder 104.

When it is determined in the step S52 that one of the "EASY" key 118e, the "+" key 118b and the "-" key 118a has been depressed, the image selecting  
10 process is performed (step S53). In this process, as described with reference to Figs. 11 to 14, the desired image can be displayed alone on the viewfinder in such a manner that nine images, for example, are simultaneously displayed on the viewfinder 104 by depressing the "EASY" key 118e; other nine images including the desired image are simultaneously displayed on the viewfinder 104  
15 by depressing the "+" key 118b; the image having the smallest photograph number among the above-described other nine images is displayed alone on the viewfinder 104 by depressing the "EASY" key 118e; that image having the smallest photograph number is switched to the next image having the second smallest photograph number among the above-described other nine images by  
20 depressing the "+" key 118b.

When the "SET" key 118c is depressed in the step S52 under the condition wherein the desired image is being displayed on the viewfinder 104, the image is determined as that to be printed (step S54). Then, the image data corresponding to the image which is being displayed is transferred from the  
25 digital camera 101 to the printer 115. In the digital camera 101, all recorded images are stored with the maximum resolution which the digital camera 101 has. Accordingly, the amount of 1-image data is relatively large. In this embodiment, the selected layout form mentioned above is checked, the resolution of the image data is changed to that according to the size which the  
30 image corresponding to the image data will have when laid out in the selected layout form, and the image data after the conversion is transferred to the printer 115. For example, when a layout form for four images is selected, the CPU 140 of the printer 115 commands the digital camera 101 to change the resolution of the image data corresponding to four images to a lower resolution  
35 (in this case, a resolution which is 1/4 that before the conversion). In response to this command, the digital camera 101 changes the resolution of the image data corresponding to the four images, and transfers the image data whose



resolution has been changed to the printer 115. The printer 115 prints the four images represented by the transferred image data on the same printing sheet P. When a layout form for nine images (refer to icons Nos. 17 and 18 shown in Fig. 15C) is selected, the CPU 140 of the printer 115 commands the digital camera 101 to change the resolution of image data corresponding to nine images to a lower resolution which is 1/9 that before the conversion. In response to the command, the resolution of the image data is changed, and the image data whose resolution has been changed are transferred to the printer 115.

10 In the case where the digital camera 101 has a fine mode in which images are recorded at a high resolution and a normal mode in which images are recorded at a low resolution, the printer 115 can designate which of an image recorded in the fine mode and that recorded in the normal mode the digital camera 101 should transfer, at the time the printer 115 outputs a request for the transfer of an image to the digital camera 101. When the printer 115 designates an image recorded in the normal mode, the image does not, in general, accord with the resolution of the printer 115 (the resolution of the image is lower). Therefore, the printer 115 changes the resolution of the image transferred from the digital camera 101 by such processing as the interpolation between the dots, and thereafter prints the image.

The image direction setting process in the step S45 will now be described in detail, with reference to the flowchart shown in Fig. 26.

When the image direction setting process is initiated, image direction setting data is first displayed on the viewfinder 104 (step S61). In this step, as shown in Fig. 31A, a character display menu which inquires how an image determined as the image to be printed is rotated and laid out in a layout form as determined is displayed on the viewfinder 104. One of two rotational directions " $\leftarrow \rightarrow A$ " (a lateral-frame image is rotated 90°) and " $A \rightarrow \triangleright$ " (a vertical-frame image is rotated 90°) can be selected. In the initial state of the image direction setting menu, a cursor 162 is displayed under " $\leftarrow \rightarrow A$ " on the left side of the menu.

When the image direction setting menu is displayed, it is determined whether any one of the keys of the key input section 144 has been depressed (step S62). A key input from the key input section 144 is waited for until it is determined in the step S62 that one of the keys of the key input section 144 has been depressed. When it is determined in the step S62 that the "MENU" key 18f has been depressed, a shift to the step S3 is performed, and the "TOP-

"MENU" is displayed on the viewfinder 104. When it is determined in the step S62 that the "BACK" key 118g has been depressed, a return to the step S51 in Fig. 25 showing the image selecting process which precedes the image direction setting process is performed.

5 When it is determined in the step S62 that the "+" key 118b or the "-" key 118a has been depressed, the cursor 58 is moved to the right or the left in accordance with the key depression (step S63). Then, returning to the step S62, a key input is waited for.

When it is determined in the step S62 that the "SET" key 118c has been  
10 depressed, under the condition wherein one of the aforementioned two rotational directions is selected by the cursor 162, the rotational direction selected by the cursor 162 is determined as the desired direction (step S64). In this step, it is determined whether to change the address of the image data stored in the image memory 141, in accordance with the direction selected by  
15 the cursor 162.

When the processes shown in the flowcharts of Figs. 25 and 26 are finished, the printing process in the step S46 shown in Fig. 24 is executed. The printing process in the step S46 is the same as that shown in Fig. 23.

The calendar printing process will now be described with reference to the  
20 flowchart illustrated in Fig. 27.

When the calendar printing process is initiated, a format selection menu is first displayed on the viewfinder 104 (step S71). When the format selection menu is displayed on the viewfinder 104, it is determined whether any one of the keys of the key input section 144 has been depressed (step S72). A key  
25 input from the key input section 144 is waited for until it is determined that one of the keys of the key input section 144 has been depressed. The format selection menu displayed in the step S71 is the calendar printing menu illustrated in Fig. 17.

When it is determined in the step S71 that the "EASY" key 118e has been  
30 depressed, a return to the step S8 shown in Fig. 22 is performed. When it is determined in the step S72 that the "MENU" key 118f has been depressed, a return to the step S3 shown in Fig. 22 is performed. When it is determined in the step S72 that the "+" key 118b or the "-" key 118a has been depressed, a cursor (not shown) is moved (step S73). Then, returning to the step 72, a key  
35 input is waited for. In the step S73, the cursor is moved in the same manner as that in the case of the step S12 shown in Fig. 22.

When it is determined in the step S72 that the "SET" key 118c has been

depressed, under the condition wherein one of the icons displayed on the format selection menu is selected by the cursor, the calendar print format represented by the icon selected by the cursor is determined as the desired format (step S73). Then, the calendar print format as determined is read out from a calendar creation area of the ROM 146, and is stored in the work area of the RAM 148. After this, the process of selecting the image to be combined with a calendar in the calendar print format as determined is performed (step S75), following which the process of setting the direction of the image as selected is performed (step S75). The image selecting process in the step S75 is the same as that shown in Fig. 25, while the image direction setting process in the step S75 is the same as that shown in Fig. 26.

When the image selecting process and the image direction setting process are finished, the year and months of the calendar are determined. In order to determine the year and the months, year setting data (a character display menu in Fig. 31B, which is used for setting the year) is first displayed on the viewfinder 104 (step 76). In the year setting menu shown in Fig. 31B, the number "2000" representing the year 2000 is displayed under the letters "YEAR INPUT", and the cursor 163 is displayed under the last digit of the number.

When the year setting menu is displayed, it is determined whether any one of the keys of the key input section 144 has been depressed (step S77). When it is determined in the step S77 that the "EASY" key 118e has been depressed, a shift to the step S8 shown in Fig. 22 is performed. When it is determined in the step S77 that the "MENU" key 118g has been depressed, a shift to the step S3 shown in Fig. 22 is performed. When it is determined in the step S77 that the "BACK" key 118g has been depressed, a return to the step S71 is performed such that the first page of the format selection menu is displayed on the viewfinder 104.

When it is determined in the step S77 that the "+" key 118b or the "-" key 118a has been depressed, the number "2000" representing the year 2000 is displayed with being changed (step S78). Upon the depressions of the "+" key 118b, the number "2000" is increased to "2001", "2002" and the following numbers. Upon the depressions of the "-" key 118a, the number "2000" is decreased to "1999", "1998" and the following numbers. Returning to the step S77 thereafter, a key input from the key input section 144 is waited for. When it is determined in the step S77 that the "SET" key 118c has been depressed, under the condition wherein the desired year is being displayed in the above-described manner, the year which is being displayed is determined as the year

of the calendar (step S79).

When the year is determined, month setting data (a character display menu in Fig. 31C, which is used for setting the months) is displayed on the viewfinder 104 (step S81). In the month setting menu illustrated in Fig. 31C, 5 the number "12" representing December is displayed under the letters "MONTH INPUT", and the cursor 163 is displayed under the last digit of the number.

When the month setting menu is displayed, it is determined in the step S81 whether any one of the keys of the key input section 144 has been depressed (step S81). When it is determined in the step S81 that the "EASY" 10 key has been depressed, a shift to the step S8 shown in Fig. 22 is performed. When it is determined in the step S81 that the "MENU" key 118f has been depressed, a shift to the step S3 shown in Fig. 22 is performed. When it is determined in the step S81 that the "BACK" key 118g has been depressed, a return to the step S76 is performed, and the year setting menu is displayed on 15 the viewfinder 104.

When it is determined in the step S81 that the "+" key 118b or the "-" key 118a has been depressed, the number "12" representing December is displayed with being changed (step S82). Upon the depressions of the "+" key 118b, the number "12" is returned to "1" and increased to "2", "3" and the 20 following numbers. Upon the depressions of the "-" key 118a, the number "12" is decreased to "11", "10", "9" and the following numbers. Returning to the step S81 thereafter, a key input from the key input section 144 is waited for. When it is determined in the step S81 that the "SET" key has been depressed, under the condition wherein the desired month is being displayed in the above- 25 described manner, the month which is being displayed is determined as a month of the calendar (step S83).

Following the above, calendar data representing the year and months determined in the steps S79 and S83 is produced based on a calendar creation program stored in the ROM 146. The calendar data as produced is temporarily 30 stored in the RAM 148. Then, the Y print data, the M print data and the C print data, all transferred from the camera 101 and stored in the print data memory area of the RAM 148, and the calendar data stored in the RAM 148 are combined in the image combining area of the RAM 148, whereby print data as the combination of an image recorded in the digital camera 101 and the image 35 of the calendar (step S84) is produced. The Y print data, the M data and the C print data are sequentially subjected to the above image combining process in the image combining area of the RAM 148. The numerals and characters in

the calendar are read out as pattern data from the CG of the ROM 146, and are stored as the calendar data in the RAM 148.

When the print data is produced in the step S84, the process of printing the image corresponding to the print data on the printing sheet P is conducted 5 (step S85). This printing process is the same as that shown in Fig. 23.

The mini label printing process will now be described with reference to the flowchart shown in Fig. 28.

When the mini label printing process in the above-mentioned flow chart is initiated, the first page of an illustration selection menu (the mini label printing 10 menu) shown in Fig. 19A is displayed on the viewfinder 104 (step S91). The illustration selection menu is that for selecting one of the image decoration patterns. Data corresponding to this menu is transferred from the printer 115 to the digital camera 101, and is displayed on the viewfinder 104.

When the illustration selection menu is displayed, it is determined 15 whether any one of the keys of the key input section 144 has been depressed (step S92). A key input from the key input section 144 is waited for until one of the keys of the key input section 144 is depressed. When it is determined in the step S92 that the "EASY" key 118e has been depressed, a shift to the step S8 shown in Fig. 22 is performed. When it is determined in the step S92 that 20 the "MENU" key 118f or the "BACK" key 118g has been depressed, a shift to the step S3 shown in Fig. 22 is performed.

When it is determined in the step S92 that the "+" key 118g has been depressed, it is determined whether that page of the illustration selection menu which is being currently displayed should be changed to the next page (step 25 S93), in accordance with the present position of a cursor (not shown). In other words, it is determined whether the cursor display address corresponds to the display position of the last icon on that page which is being currently displayed.

When it is determined that the cursor display address corresponds to the display address of the last icon (the result of the determination in the step S93 is 30 "Yes"), that page which is being displayed is switched to the next page (the second page behind the first page in Fig. 19A), and the cursor is displayed under the first icon on that next page (step S94). When it is determined that the cursor display position does not correspond to the display position of the last icon (the result of the determination in the step S93 is "No"), the cursor is 35 moved to the icon following that under which the cursor is located (step S95). Then, returning to the step S92, a key input from the key input section 144 is waited for. In this manner, the icons are sequentially selected in ascending

order of the numbers allotted to the icons.

When it is determined in the step S92 that the “-” key 118a has been depressed, it is determined whether that page of the illustration selection menu which is being currently displayed should be changed to the preceding page, in  
5 accordance with the present position of the cursor (not shown). In other words, it is determined whether the cursor display address corresponds to the display position of the first icon on that page which is being currently displayed.

When it is determined that the cursor display address corresponds to the display position of the first icon (the result of the determination in the step S96 is  
10 “Yes”), that page which is being currently displayed is switched to the preceding page (the undermost page in the case of Fig. 19A), and the cursor is displayed under the last icon on that preceding page (step S97). When it is determined that the cursor display address does not correspond to the display position of the first icon on that page which is being currently displayed (the result of the  
15 determination in the step S96 is “No”), the cursor is moved to the icon preceding that under which the cursor is located (step S98). Then, returning to the step S92, a key input from the key input section 144 is waited for. Thus, the icons are sequentially selected in descending order of the numbers allotted to the icons.

20 When it is determined in the step S92 that the “SET” key 118c has been depressed, under the condition wherein one of the icons is selected by the cursor in the above-described manner, the image decoration pattern represented by the icon selected by the cursor is determined as the desired one (step S99). When the image decoration pattern is determined, the image (the  
25 reproduced image) having photograph No. 1 and stored in the digital camera 101 is displayed on the viewfinder 101 as shown in Fig. 11A (step S100).

When the reproduced image is displayed on the viewfinder 104, it is determined whether any one of the keys of the key input section 144 has been depressed (step S101). Until one of the keys is depressed, a key input from  
30 the key input section 144 is waited for. When it is determined in the step S101 that the “EASY” key 118e has been depressed, a shift to the step S8 shown in Fig. 22 is performed. When it is determined in the step S101 that the “MENU” key 118f has been depressed, a shift to the step S3 shown in Fig. 22 is performed. When it is determined in the step S101 that the “BACK” key 118g  
35 has been depressed, a return to the step S91 is performed.

When it is determined in the step S101 that the “+” key 118b has been depressed, the next image having a greater photograph number is displayed on

the viewfinder 104 (step S103). When that image is displayed on the viewfinder 104, a return to the step S101 is performed, and a key input from the key input section 144 is waited for. Each time the "+" key 118a is depressed, the image which is being currently displayed on the viewfinder 104 is switched  
5 to the next image having a greater photograph number.

When it is determined in the step S101 that the "-" key 118a has been depressed, the image which is being currently displayed on the viewfinder 104 is switched to the preceding image (step S103). Then, returning to the step S101, a key input from the key input section 144 is waited for. Each time the  
10 "-" key 118a is depressed, the image which is being currently displayed on the viewfinder 104 is switched to the preceding image having a smaller photograph number.

When it is determined in the step S101 that the "SET" key 118c has been depressed, under the condition wherein the desired image is being displayed  
15 on the viewfinder 104 in the above-described manner, that image is determined as the image to be printed (step S104). Then, the image data corresponding to the image which is being displayed is transferred from the digital camera 101 to the printer 115, and is temporarily stored in the image memory 141. The image data, which is transferred from the digital camera 101, is the image data  
20 of a resolution reduced to 1/4 or 1/9. The expansion section 142 of the printer 115 changes the resolution of the image stored temporarily in the image memory 141, so as to be 1/20 that which the image has when displayed alone on the viewfinder 104. Then, as shown in Fig. 19B, print data as the combination of twenty images and the image decoration pattern is created, and  
25 the printing process is executed (step S105). This printing process is the same as that shown in Fig. 23.

The card (postcard) printing process will now be described with reference to the flowchart shown in Fig. 29.

When the card (postcard) printing process in the above flowchart is  
30 initiated, the first page of the format selection menu illustrated in Fig. 20A is first displayed on the viewfinder (step S110). Menu data representing the format selection menu is also transferred from the printer 115 to the digital camera 101 such that the format selection menu is displayed on the viewfinder 104.

When the format selection menu is displayed, it is determined whether  
35 any one of the keys of the key input section 144 has been depressed (step S111). Until one of the keys is depressed, a key input from the key input section 144 is waited for. When it is determined in the step S111 that the

"EASY" key 118e has been depressed, a shift to the step S8 shown in Fig. 22 is performed. When it is determined in the step S111 that the "MENU" key 118f or the "BACK" key 118g has been depressed, a shift to the step S3 shown in Fig. 22 is performed.

5        When it is determined in the step S111 that the "+" key 118b has been depressed, it is determined whether the first page of the format selection menu should be switched to the next page (step S112), in accordance with the current position of a cursor (not shown). In other words, it is determined whether the cursor display address corresponds to the display position of the last icon on  
10 the first page.

When it is determined that the cursor display address corresponds to the display position of the last icon on the first page (the result of the determination in the step S112 is "Yes"), the first page is switched to the next page (the second page behind the first page in Fig. 20A), and the cursor is displayed  
15 under the first icon on the aforementioned next page (step S113). When it is determined that the cursor display position does not correspond to the display position of the last icon on the first page (the result of the determination in the step S112 is "No"), the cursor is moved to under the icon following that under which the cursor is located (step S114). Then, returning to the step S111, a  
20 key input from the key input section 144 is waited for. In this manner, the "POSTCARD" icons are sequentially selected in ascending order of the numbers allotted to the icons.

When it is determined in the step S111 that the "-" key 118a has been depressed, it is determined whether that page of the format selection menu  
25 which is being currently displayed should be changed to the preceding page (step S115). In other words, it is determined whether the cursor display address corresponds to the display position of the first icon on that page which is being displayed.

When it is determined that the cursor display address corresponds to the  
30 display position of the first icon (the result of the determination in the step S115 is "Yes"), the page which is being currently displayed is switched the preceding page (the undermost page in Fig. 20A), and the cursor is displayed under the last icon on that preceding page (step S116). When it is determined that the cursor display position does not correspond to the display position of the last  
35 icon on the first page (the result of the determination in the step S112 is "No"), the cursor is moved to under the icon preceding that under which the cursor is located (step S117). Then, returning to the step S111, a key input from the key



input section 144 is waited for. In this manner, the "POSTCARD" icons are sequentially selected in descending order of the numbers allotted to the icons.

When it is determined in the step S101 that the "SET" key 118c has been depressed, under the condition wherein one of the icons displayed on the  
5 format selection menu is selected by the cursor, the pattern shown by the icon selected by the cursor is determined as the desired pattern (step S118). In this case also, the image data corresponding to the pattern as determined is stored in the RAM 148. Next, the image selecting process is performed (step 119), after which the image direction setting process is conducted (step S120). The  
10 image selecting process and the image direction setting process are the same as those shown in Figs. 25 and 26, respectively. By the processes in the steps S119 and S120, an image to be printed and its direction are determined, and the image data corresponding to the image as determined is stored in the RAM 148 (step S121). When the image is determined, the year setting menu shown  
15 in Fig. 31B is displayed on the viewfinder 104 (step S122).

When the year setting menu is displayed on the viewfinder 104, it is determined whether any one of the keys of the key input section 144 has been depressed (step S123). Until one of the keys is depressed, a key input from the key input section 144 is waited for. When it is determined in the step S123  
20 that the "EASY" key 118e has been depressed, a shift to the step S8 shown in Fig. 22 is performed. When it is determined in the step S123 that the "MENU" key 118f has been depressed, a shift to the step S3 shown in Fig. 22 is performed. When it is determined in the step S123 that the "BACK" key 118g has been depressed, a return to the step S119 is performed.

25 When it is determined in the step S123 that the "+" key 118b has been depressed, the year is increased by "1" (step S124). When it is determined in the step S123 that the "-" key 118a has been depressed, the year is decreased by "1" (step S125). The processes in the steps 124 and 125 are the same as those explained in relation to the step S78 of the calendar printing process  
30 shown in Fig. 27. When the year is increased or decreased by "1" in the step S124 or S125, a return to the step S122 is performed.

When it is determined in the step S123 that the "SET" key has been depressed, under the condition wherein the desired year is being displayed, the year is determined as the year to be printed (step S126). The characters  
35 which represent the year are read out as font patterns from the CG of the ROM 146, and are combined with an image recorded by the camera 101, thus producing print data. The image corresponding to the print data as produced

is printed (step S127). This printing process is also the same as that shown in Fig. 23.

The image list (index) printing process will now be described with reference to the flowchart shown in Fig. 30.

5 When the image list (index) printing process in the above flowchart is initiated, image-number data specifying the number of images recorded by the digital camera 101 and stored in the image memory 127 is transferred from the digital camera 101 to the printer 115 (step S130). When it is confirmed that the reception of the image-number data is finished (step S131), a character  
10 display menu is created and transferred to the digital camera 101, and is displayed on the viewfinder 104 (step S132). In the case where the number of pixels of the CCD 121 in the digital camera 101 is 350,000, the character display menu shown in Fig. 32A is created. In the case where the number of pixels of the CCD 121 is less than 350,000, the character display menu shown  
15 in Fig. 32B is created.

The number of image data is specified in " \* \* \* " of the part "NORMAL \* \* \* PAGES" of the character display menu illustrated in Fig. 32A. More specifically, the number of stored images of 320 dots  $\times$  240 dots is shown in " \* \* \* ". The number of image data is shown also in " \* \* " of the part "FINE \* \* \* PAGES".  
20 However, the number of fine stored images of 640 dots  $\times$  480 dots is shown in " \* \* ". The display menu illustrated in Fig. 32B does not have the part "NORMAL \* \* \* PAGES" or "FINE \* \* \* PAGES", and the number of stored images is shown in " \* \* " simply as " \* \* PAGES". In this case, image data representing relatively low resolution images of 320 dots  $\times$  240 dots are  
25 stored in the image memory of the digital camera 101.

In accordance with the image-number data received in the step S130, data representing characters (numerals) corresponding to the number specified by the image-number data, and addresses showing the positions in which the characters are to be displayed are transferred to the digital camera 101 after  
30 data representing the character display menus illustrated in Fig. 32A or Fig. 32B have been transferred to the digital camera 101 and displayed on the viewfinder 104, whereby the number of images as recorded is displayed on the part " \* \* \* " or " \* \* ".

When the number of recorded images is displayed, it is determined  
35 whether any one of the keys of the key input section 144 has been depressed (step S134). Until it is determined that one of the keys has been depressed, a key input from the key input section 144 is waited for. When it is determined in

the step S134 that the "EASY" key 118e has been depressed, a shift to the step S8 shown in Fig. 22 is performed. When it is determined in the step S134 that the "MENU" key 118f or the "BACK" key 118g has been depressed, a shift to the step S3 shown in Fig. 2 is performed.

5       When it is determined in the step S132 that the "SET" key 118c has been depressed, under the condition wherein while the number of recorded images is being displayed, the character display menu illustrated in Fig. 32C is created and transferred to the digital camera 101, and is displayed on the viewfinder 104 (step S135). The character display menu illustrated in Fig. 32C inquires of  
10 a user as to whether to perform printing or not. In the case of "YES", the user is instructed to load the printing sheet P through the sheet insertion/discharge slot 116, while in the case of "No", the user is instructed to press the "MENU" key 118f.

Next, it is determined by means of the sensor 154 whether the printing  
15 sheet P has been loaded through the sheet insertion/discharge slot 116 (step S136). When the sensor 154 senses the insertion of the printing sheet P (the result of the determination in the step S136 is "Yes"), printing is started (step S137). Then, in accordance with the number of recorded images, the list (index) of all images is printed with those images being laid out as shown in Fig.  
20 21A, Fig. 21B or Fig. 21C.

When the number of recorded images is ten or greater and accordingly the recorded images are displayed in a 10 × 10 matrix pattern, all of those images are printed as thumbnail images (images each being formed of 52 dots × 36 dots).

25       When it is confirmed that the printing started in the step S137 has been finished (the result of the determination in step 138 is "Yes"), the "TOP-MENU" is displayed. When the sensor 154 does not sense the insertion of the printing sheet P in the step S136, it is determined whether any one of the keys of the key input section 144 has been depressed (step S139). Until it is determined in  
30 the step S139 that one of the keys has been depressed, a key input from the key input section 144 is waited for.

When it is determined in the step 92 that the "EASY" key 118e has been depressed, a shift to the step S8 shown in Fig. 22 is performed. When it is determined in the step S92 that the "MENU" key 118f or the "BACK" key 118g  
35 has been depressed, a shift to the step S3 shown in Fig. 22 is performed.

Thus, by performing the key depressing operation without inserting the printing sheet P, the user can cancel the list (index) printing process and can

make another process executed.

High-speed printing can be achieved also in the case of printing a large number of images by the above-described list (index) printing process, if the digital camera 101 converts the image data corresponding to the large number of images to thumbnail image data and transfers those thumbnail image data to the printer 115, as in the case of changing the resolution of image data corresponding to four (nine) images to a lower resolution which is 1/4 (1/9) that before the conversion.

In the step S130, the image-number data specifying the number of images which have been recorded by the digital camera 101 and stored in the image memory 127 is transferred from the digital camera 101 to the printer 115. However, data specifying the number of images which can be further recorded by the digital camera 101 may be transferred to the printer 115.

The recording medium on which an image is printed with the printer 115 of the second embodiment is not limited to the printing sheet P, and may be an adhesive label with a separable paper, or a transparent film. The color printer 147 may print an image by employing systems such as an ink jet system other than the thermal printing system.

## CLAIMS

1. A printing apparatus which is detachably connected to an image recording apparatus (10) and which is capable of communicating with said image recording apparatus (10), said image recording apparatus (10) comprising image fetching means (31-34) for fetching, as digital signals, image information units each representing a still image, an image memory (37) for storing the image information units fetched by said image fetching means (31-34), display means (13) for displaying the image information units stored in said image memory (37), and control means (42) for controlling said image memory (37) and said display means (13) in accordance with an externally received control signal,

said printing apparatus being characterized by comprising:

input means (52) for inputting control signals;

first control means (51) for receiving a first control signal input from said input means (52) and sending said first control signal to said control means (42) of said image recording apparatus (10), in order to cause said control means (42) of said image recording apparatus (10) to read out at least one of the image information units stored in said image memory (37), and in order to cause said display means (13) to display the image represented by said at least one image information unit read out from said image memory (37);

second control means (51) for receiving a second control signal input from said input means (52) and sending said second control signal to said control means (42) of said image recording apparatus (10), in order to cause said control means (42) of said image recording apparatus (10) to output said at least one image information unit representing the image displayed on said display means (13) to said printing apparatus;

image information receiving means (55) for receiving said at least one image information unit output from said image recording apparatus (10); and

printing means (61) for printing on a recording medium (X) the image represented by said at least one image information unit received by said image information receiving means (55).

2. The printing apparatus according to claim 1, characterized by further comprising:

third control means for receiving a third control signal input from said input means (52) and sending said third control signal to said control means (42) of said image recording apparatus (10), in order to cause said control means (42) of said image recording apparatus (10) to set the direction of an

image to be displayed on said display means (13); and

storing means (54c) for storing direction information corresponding to the direction set by said control means (42) of said image recording apparatus (10) when said third control signal is input from said input means (52), said printing  
5 means (61) printing the image represented by said at least one image information unit received by said image information receiving means (55), in accordance with the direction information stored in said storing means (54c).

3. The printing apparatus according to claim 2, characterized in that said third control signal includes data specifying the direction of the image to be  
10 displayed on said display means (13).

4. The printing apparatus according to claim 1, characterized in that said image information receiving means (55) receives image information output from said image recording apparatus (10) in the form of compressed data, said printing apparatus further comprises expanding means (59) for expanding the  
15 image information received by said image information receiving means (55), and said printing means (61) prints an image represented by the image information expanded by said expanding means (59) on said recording medium (X).

5. The printing apparatus according to claim 1, characterized by further  
20 comprising:

format storing means (53) for prestoring print format data representing print formats and selection display menu data for selecting a desired one of said print formats;

fourth control means (51) for receiving a fourth control signal from said  
25 input means (52) and sending, together with said fourth control signal, the selection display menu data stored in said format storing means (53) to said control means (42) of said image recording apparatus (10), in order to cause said control means (42) of said image recording apparatus (10) to display on said display means (13) an image corresponding to said selection display menu  
30 data;

selecting means (52) for selecting one of said print formats, based on the image corresponding to said selection display menu data and displayed on said display means (13); and

print data producing means (51, 60) for producing print data representing  
35 an image to be printed, based on at least the image information received from said image recording apparatus (10) and the print format data selected by said selecting means (52), and for supplying said print data to said printing means

(61).

6. The printing apparatus according to claim 5, characterized in that said printing apparatus further comprises time measuring means (56) for measuring time information, said print formats include a print format having an area (A4) in which an image corresponding to the time information measured by said time measuring means (56) is to be printed, and said print data producing means (51, 60) produces said print data, based on the image information received from said image recording apparatus (1), the print format data selected by said selecting means (52) and the time information measured by said time measuring means (56).

7. The printing apparatus according to claim 1, characterized by further comprising power source control means (51) for shutting off a supply of power to said printing apparatus (20) when no control signal is input said input means (52) for a predetermined period of time.

8. A printing apparatus which is detachably connected to an image recording apparatus (101) via communication means (138), said image recording apparatus (101) storing digital signals obtained from an optical image formed by a lens unit (103a) in an image memory (127) as image data, sending data including said image data to said printing apparatus through said communication means (138), receiving control signals or data containing said image data from said printing apparatus, and displaying on display means (104) the image data stored in said image memory (127) or the image data received through said communication means (138), in accordance with a control performed by control means (130),

said printing apparatus being characterized by comprising:

storing means (146) for storing printer operation image data for causing said display means (104) to display an image for selecting a desired one of a plurality of formats, and for storing image data corresponding to said formats;

first control means (140) for sending said printer operation image data to said communication means (138) of said image recording apparatus (101), in order to cause said control means (130) of said image recording apparatus (101) to display on said display means (104) an image corresponding to said printer operation image data;

format selecting means (144) for selecting a desired one of said formats in accordance with the image corresponding to said printer operation image data and displayed on said display means (104);

second control means (140) for sending a first control signal to said

control means (130) through said communication means (138), in order to cause said control means (130) of said image recording apparatus (101) to read out the image data stored in said image memory (127) and display the read-out image data on said display means (104);

5 image selecting means (144) for selecting desired image data among the image data displayed on said display means (104);

format image reading means (140) for reading out, from said storing means (146), image data corresponding to the format selected by said format selecting means (144);

10 third control means for sending a second control signal corresponding the image data selected by said image selecting means (144) to said control means (130) through said communication means (138) of said image recording apparatus (101), in order to cause said control means (130) to read out from said image memory (127) the image data selected by said image selecting  
15 means (144) and send the read-out image data through said communication means (138);

receiving means (145) for receiving the image data sent through said communication means (138) in response to said second control signal sent from said third control means (140);

20 print image producing means (140, 148) for producing print image data representing an image to be printed, based on the image data read out by said format image reading means (140) and the image data received by said receiving means (145); and

printing means (147) for printing the print image data produced by said  
25 print image producing means (140, 148) on a recording medium (P).

9. The printing apparatus according to claim 8, characterized in that the image data stored in said storing means (146) are compressed data, and said print image producing means includes expanding means (142) for expanding said image data.

30 10. The printing apparatus according to claim 8, characterized in that the image data received by said receiving means (145) from said image recording apparatus (101) is compressed data, and said print image producing means includes expanding means (142) for expanding said image data.

11. A printing system wherein image data representing still images  
35 recorded by and kept in an image recording apparatus (101) are transferred to a printing apparatus (115) and are printed by said printing apparatus (115), said printing system being characterized by comprising:



storing means (146) for prestoring printer operation image data for selecting a desired one of a plurality of formats, and image data corresponding to said formats;

5 display means (104) for displaying an image corresponding to said printer operation image data which is read out from said storing means (146), and for displaying at least one of the images represented by the image data kept in said image recording apparatus (101);

10 selecting means (144) for selecting a desired one of said formats in accordance with the printer operation image data displayed on said display means (104), and for selecting desired image data from image data displayed on said display means (104);

print data producing means (140, 148) for producing print image data to be printed, based on the image data kept in said image recording apparatus (101) and selected by said selecting means (144) and the image data  
15 corresponding to the format selected by said selecting means (144) and stored in said storing means (146);

printing means (147) for printing the image data produced by said print data producing means (149, 148) on a recording medium (P).

12. The printing system according to claim 11, characterized in that said  
20 printer operation image data is compressed data, said printing system further comprises expanding means (142) for expanding said printer operation image data, and said display means (104) displays an image corresponding to said printer operation image data expanded by said expanding means (142).

13. The printing system according to claim 11, characterized in that the  
25 image data kept in said image recording means (101) are compressed data, said printing system further comprises expanding means (142) for expanding said image data, and said display means (104) displays images corresponding to said image data expanded by said expanding means (142).

14. A printing apparatus which receives recorded image data from an  
30 image recording apparatus (101) and which prints an image corresponding to the received image data, said image recording apparatus including display means (104) having a function of displaying a still image while being recorded in a recording mode and a function of displaying the recorded still image in a playback mode,

35 said printing apparatus being characterized by comprising:

storing means (146) for storing operation display data required to perform a print operation;

first control means (130) for transferring the operation display data stored in said storing means (146) to said image recording apparatus (101) in order to cause said image recording apparatus (101) to display on said display means (104) an image corresponding to said operation display data;

5 print commanding means (144) for generating a command to perform the print operation in accordance with the image corresponding to said operation display data and displayed on said display means (104);

second control means (130) for causing said image recording means (101) to transfer said recorded image data, in response to the command  
10 generated by said print commanding means (144); and

printing means (147) for printing the image corresponding to said recorded image data transferred from said image recording means (101) on a printing sheet (P).

15 15. The printing apparatus according to claim 14, characterized in that said printing apparatus has no display means for displaying said operation display data required to perform the print operation.

16. A printing apparatus which is detachably connected to an image recording apparatus (101) via communication means (138), said image recording apparatus (101) storing digital signals obtained from an optical image  
20 formed by a lens unit (103a) in an image memory (127) as image data, sending data including said image data to said printing apparatus through said communication means (138), receiving control signals or data containing said image data from said printing apparatus, and displaying on display means (104) the image data stored in said image memory (127) or the image data received  
25 through said communication means (138), in accordance with a control performed by control means (130),

said printing apparatus being characterized by comprising:

printing means (147) for printing, at a predetermined resolution, an image corresponding to the image data transferred from said image recording means  
30 (101) on a recording medium (P) and;

print control means (140) for sending an image transfer request signal to said control means (130) of said image recording apparatus (101) through said communication means (138) in order to make said control means (130) change the resolution of the image data stored in said image memory (137) to a  
35 resolution suitable for being printed by said printing means (147) and transfer the image data whose resolution has been changed, said printing means (147) printing the image corresponding to the image data transferred from said image

recording means (101) on the recording medium (P), without changing the resolution of the image data transferred from said image recording means (101).

17. The printing apparatus according to claim 16, characterized in that  
5 said print control means (140) sends to said control means (13) an image transfer request signal for requesting the transfer of image data representing images the number of which is  $n$ , said control means (130) changes the resolution of said image data of the number  $n$  to a resolution of  $1/n$ , and said printing means (147) prints the images corresponding to said image data  
10 transferred from said image recording apparatus (101), without changing the resolution of said image data.

18. A printing system wherein image data representing still images recorded by and kept in an image recording apparatus (101) are transferred to a printing apparatus (115) and are printed by said printing apparatus (115), said  
15 image recording apparatus (101) comprising resolution changing means (126) for changing the resolution of the image data kept in said image recording apparatus (101) to a resolution suitable for being printed by said printing apparatus (115), and transfer means (138) for transferring to said printing apparatus (115) the image data whose resolution has been changed, and said  
20 printing apparatus (115) printing images corresponding to said image data transferred by said transfer means (138) on a printing medium (P), without changing the resolution of said image data transferred by said transfer means (138).

19. A printing apparatus which is detachably connected to an image  
25 recording apparatus (101) via communication means (138), said image recording apparatus (101) storing digital signals obtained from an optical image formed by a lens unit (103a) in an image memory (127) as image data, sending data including said image data to said printing apparatus through said communication means (138), receiving control signals or data containing said  
30 image data from said printing apparatus, and displaying on display means (104) the image data stored in said image memory (127) or the image data received through said communication means (138), in accordance with a control performed by control means (130),

said printing apparatus being characterized by comprising:

35 first commanding means (144) for commanding said control means (130) of said image recording apparatus (101) to transfer information pertaining to the internal condition of said image recording apparatus (101);

display control means (140) for producing display data on the basis of said information pertaining to the internal condition of said image recording apparatus (101) and transferred from said image recording apparatus (101), and for outputting said display data to said control means (130) in order to  
5 display an image corresponding to said display data on said display means (104);

second commanding means (144) for commanding said control means (130) of said image recording apparatus (101) to transfer the image data stored in said image memory (127); and

10 printing means (147) for printing on a recording medium (P) an image corresponding to the image data transferred from said image recording apparatus (101) in response to the command generated by said second control means (144).

20. The printing apparatus according to claim 19, characterized in that  
15 said information pertaining to the internal condition of said image recording apparatus (101) is data representing the number of still images stored in said image memory (127) of said image recording apparatus (101), said display control means (140) transfers to said image recording apparatus (101) the display data produced on the basis of said data representing the number of still  
20 images stored in said image memory (127), and said display means (104) displays said display data, thereby indicating the number of still images stored in said image memory (127).

21. The printing apparatus according to claim 19, characterized in that  
25 said information pertaining to the internal condition of said image recording apparatus (101) is data representing the number of still images which can be further stored in said image memory (127), said display control means (140) transfers to said image recording apparatus (101) the display data produced on the basis of said data representing the number of still images which can be further stored in said image memory (127), and said display means (104)  
30 displays said display data, thereby indicating the number of still images which can be further stored in said image memory (127).

FIG.1

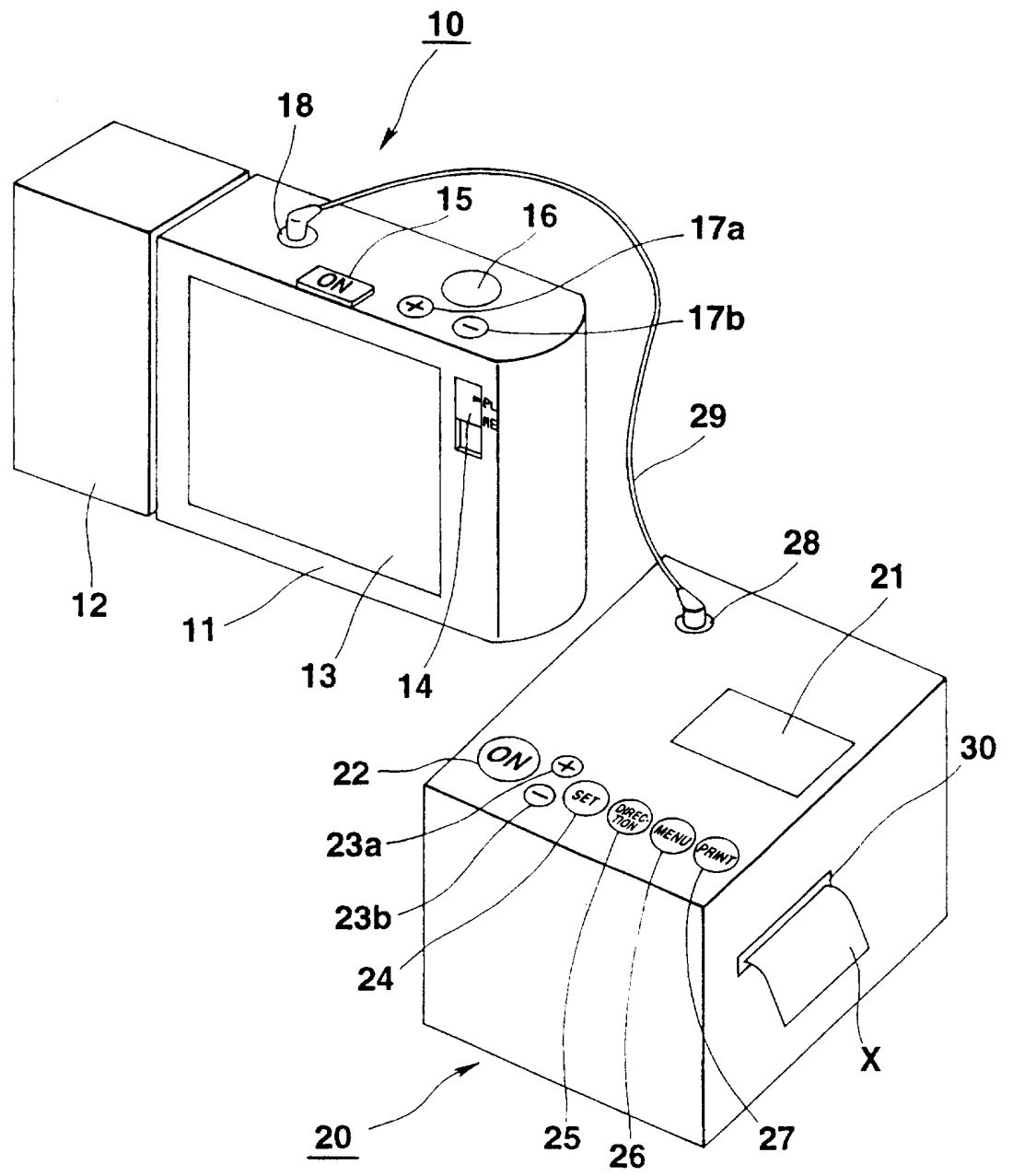
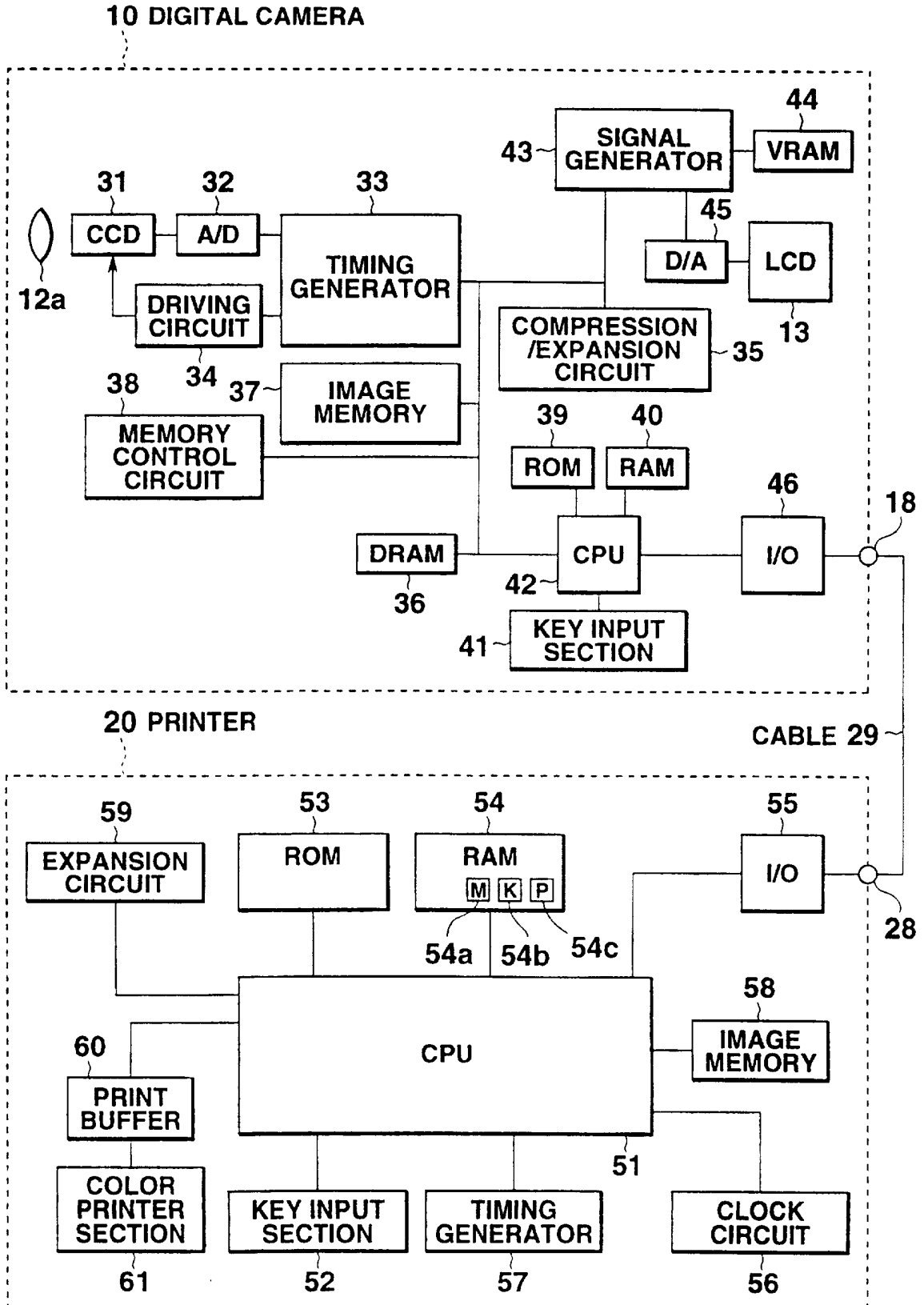
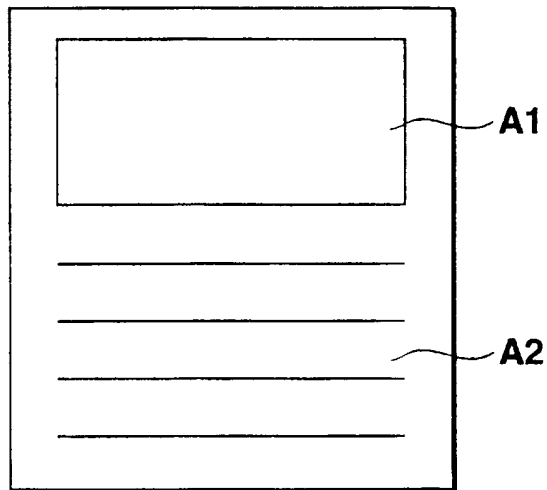


FIG.2



# FIG.3A

## POST CARD PRINTING FORMAT



# FIG.3B

## CALENDAR PRINTING FORMAT

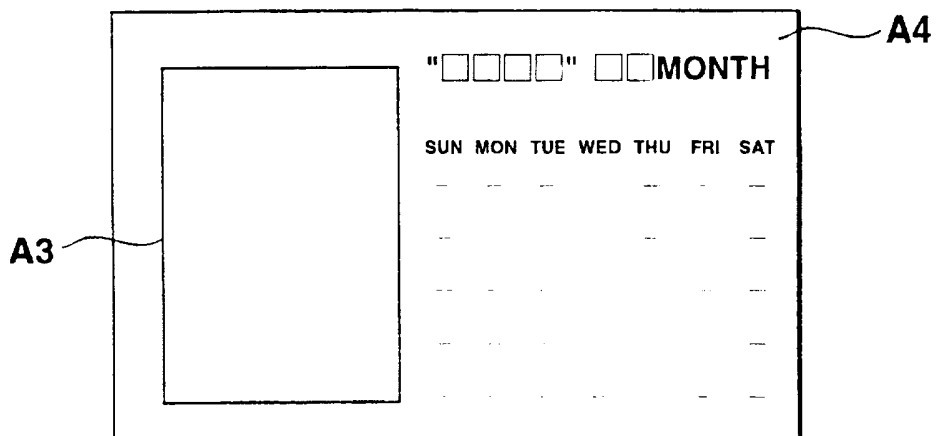
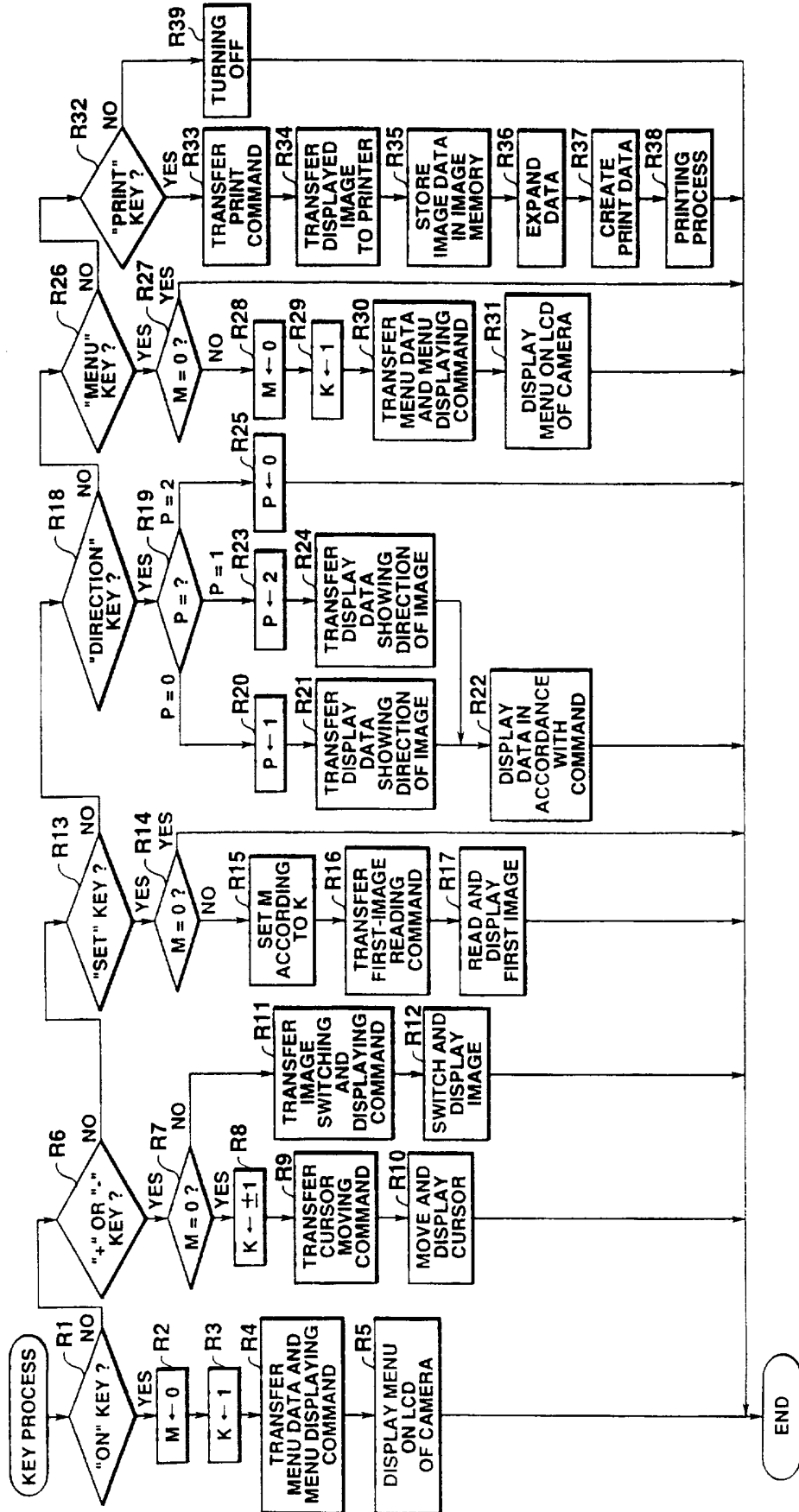


FIG.4





5/31

FIG.5A

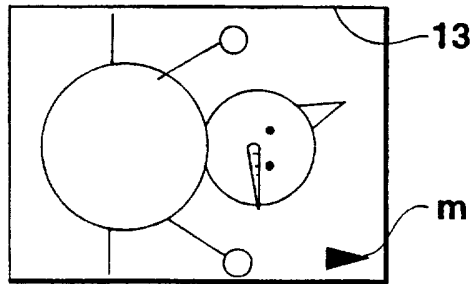


FIG.5B

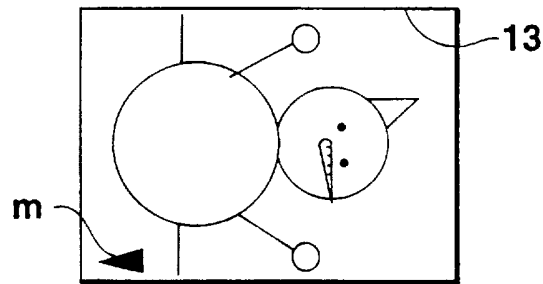


FIG.6

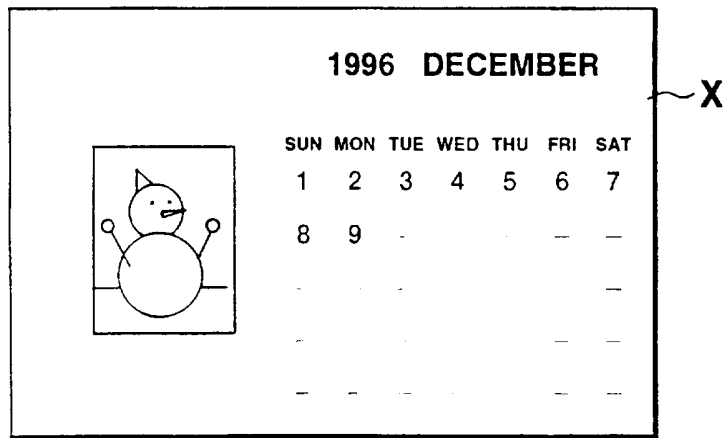


FIG.7

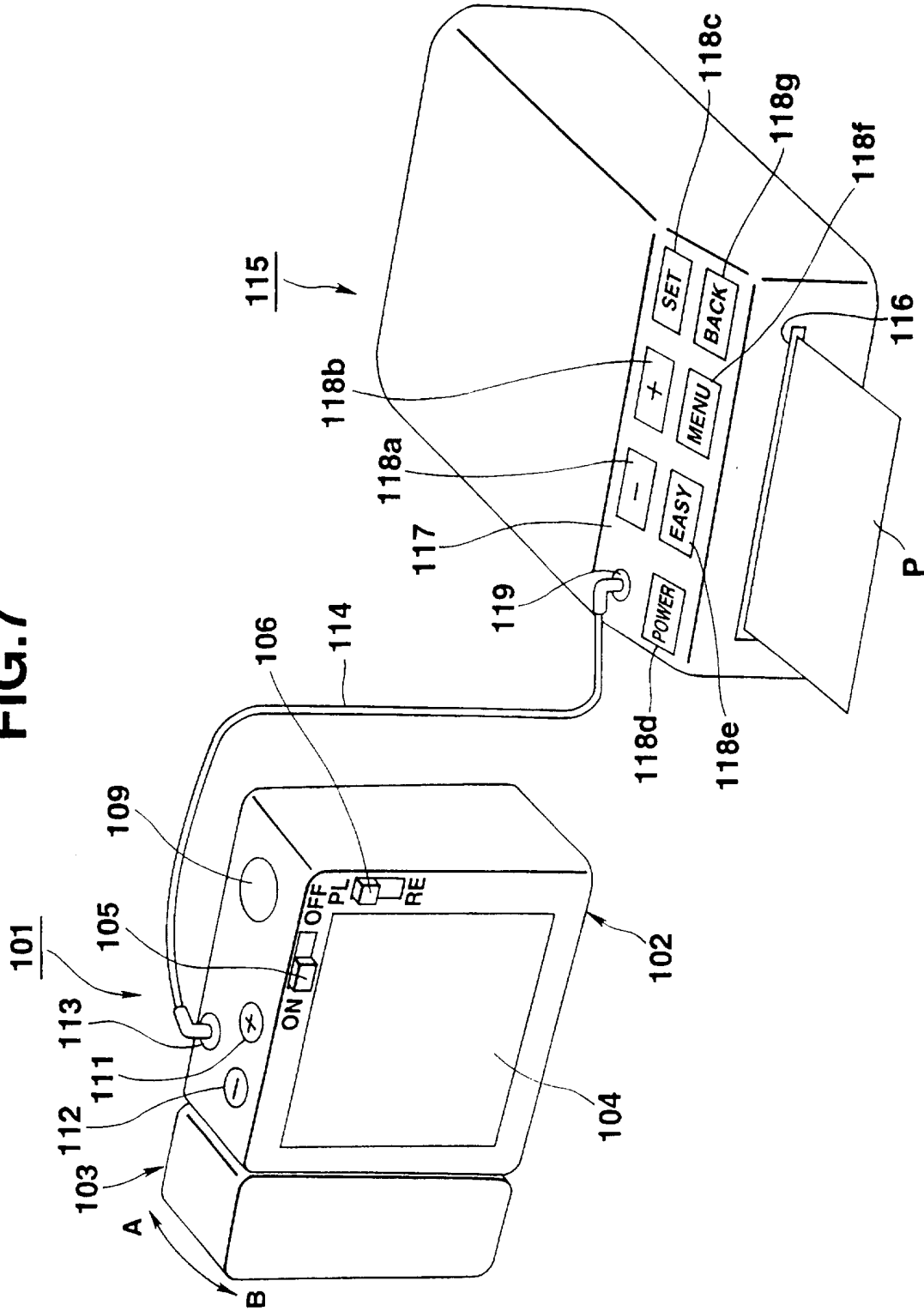


FIG.8

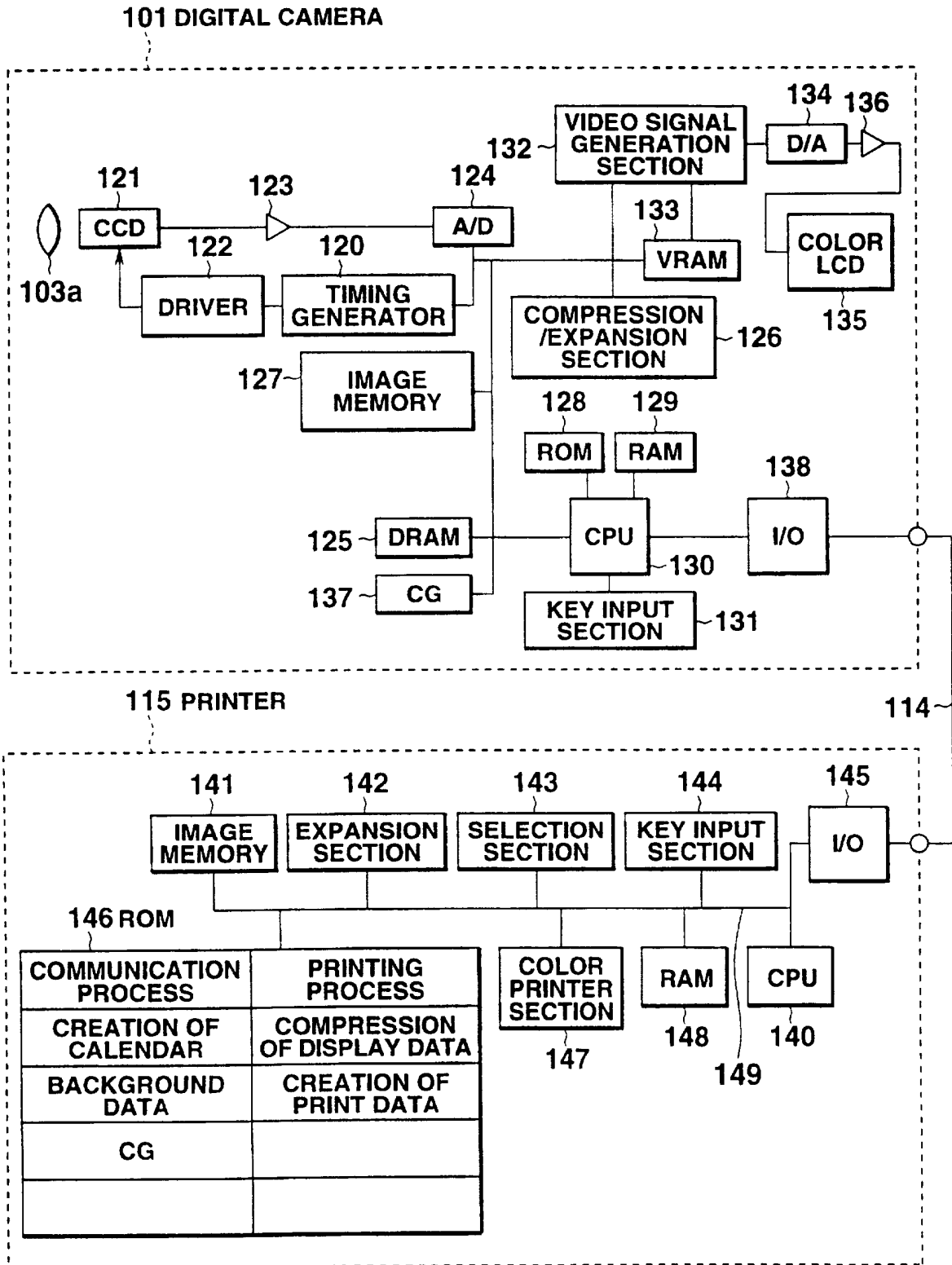
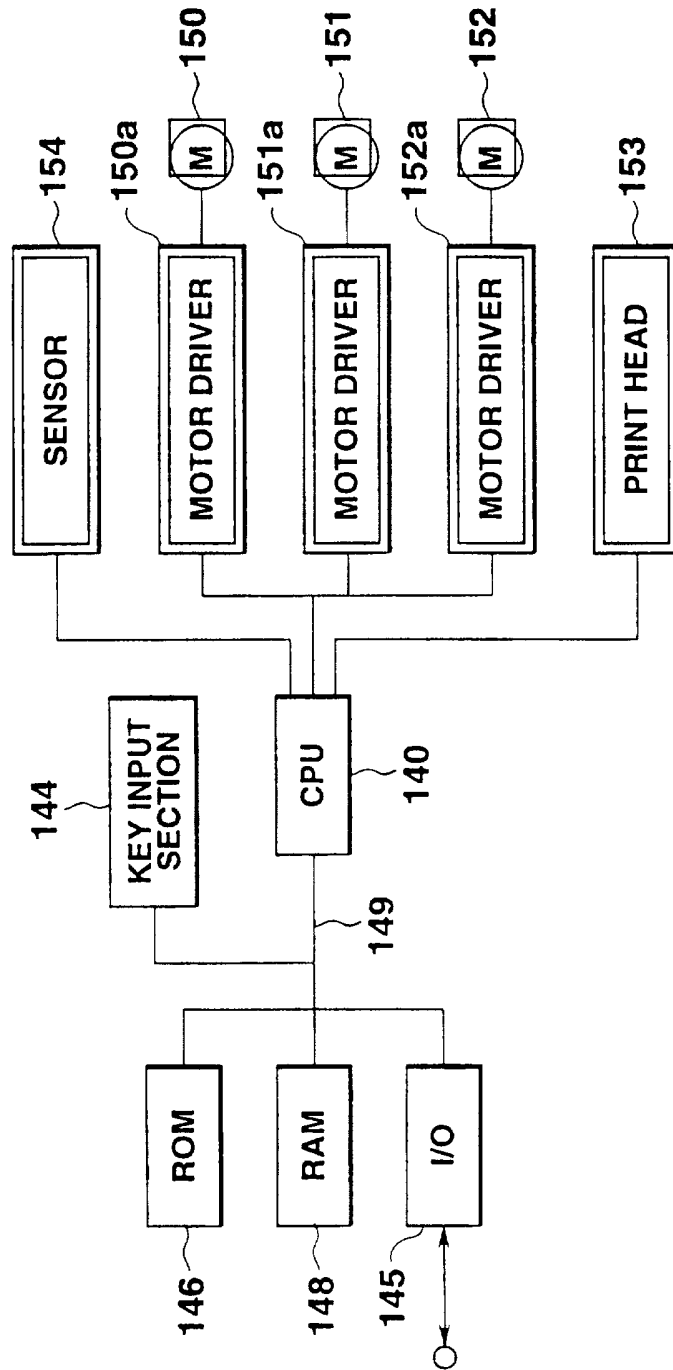
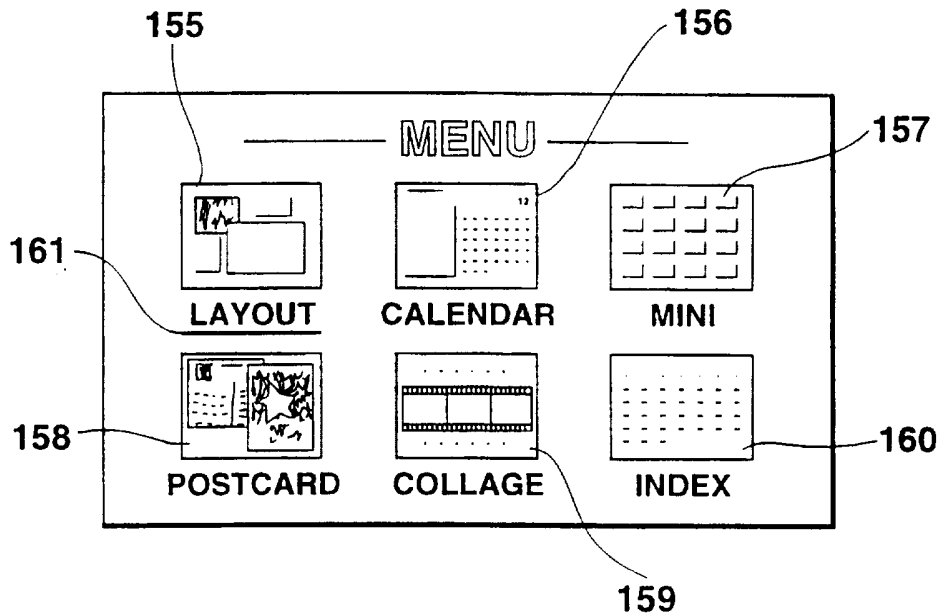


FIG.9



# FIG.10

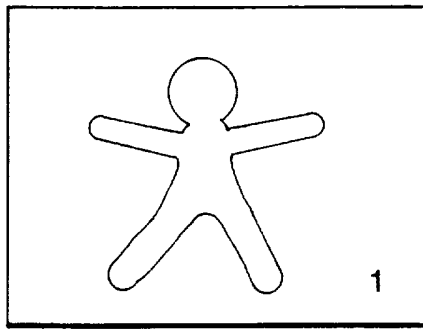
DISPLAY OF TOP-MENU



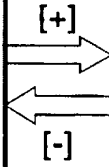
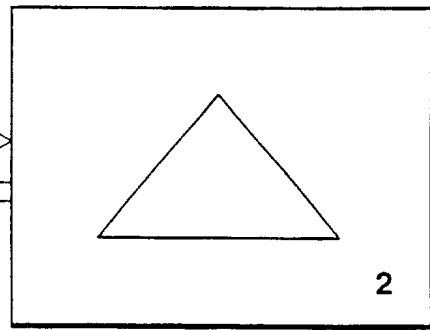
- EASY** : EXECUTE EASY PRINT
- MENU** : CANCEL
- BACK** : CANCEL
- / +** : SELECT MENU
- SET** : EXECUTE SELECTED MENU

10/31

**FIG.11A**

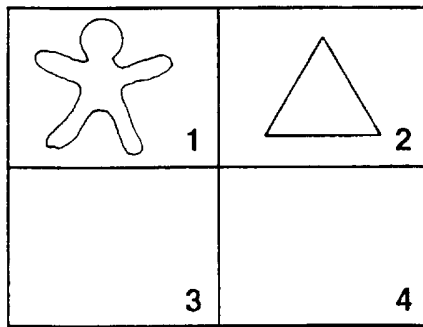


**FIG.11D**

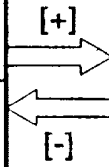
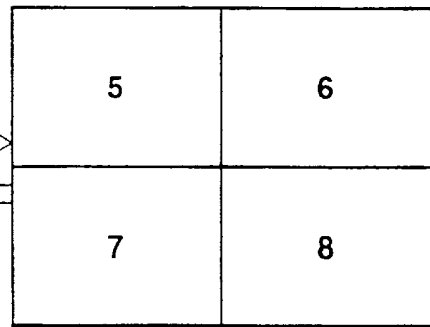


[EASY]  
↓

**FIG.11B**

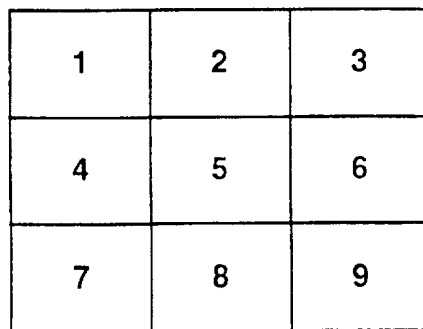


**FIG.11E**

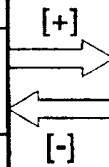
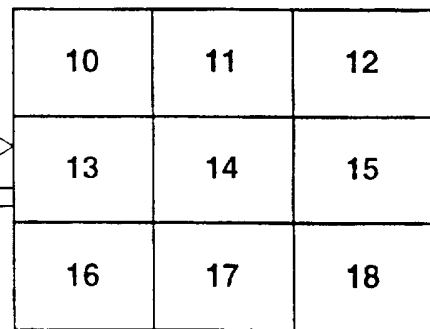


[EASY]  
↓

**FIG.11C**

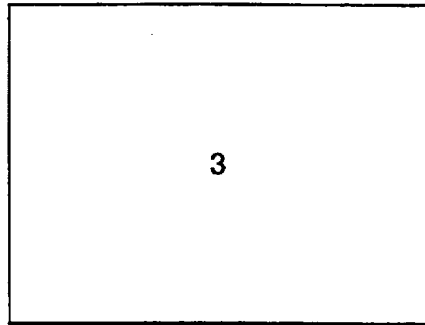


**FIG.11F**



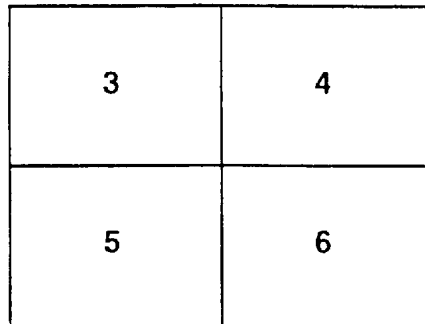
11/31

**FIG.12A**



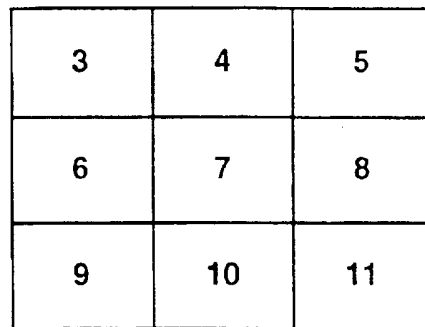
↓ [EASY]

**FIG.12B**



↓ [EASY]

**FIG.12C**



**FIG.13A**

9	×
×	×

**FIG.13B**

1	2
3	4

← [-]

← [-]

**FIG.13C**

3	4
5	6

**FIG.13D**

→ [+]

7	8
9	×

**FIG.13E**

→ [+]

1	2
3	4



**FIG.14A**

10	11	12
13	14	15
×	×	×

**FIG.14B**

1	2	3
4	5	6
7	8	9

← [-]

← [-]

**FIG.14C**

3	4	5
6	7	8
9	10	11

**FIG.14D**

12	13	14
15	×	×
×	×	×

→ [+]

**FIG.14E**

1	2	3
4	5	6
7	8	9

→ [+]

FIG.15A

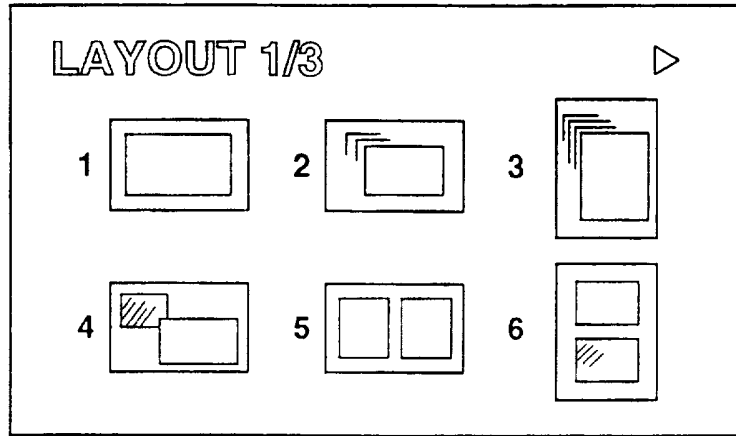


FIG.15B

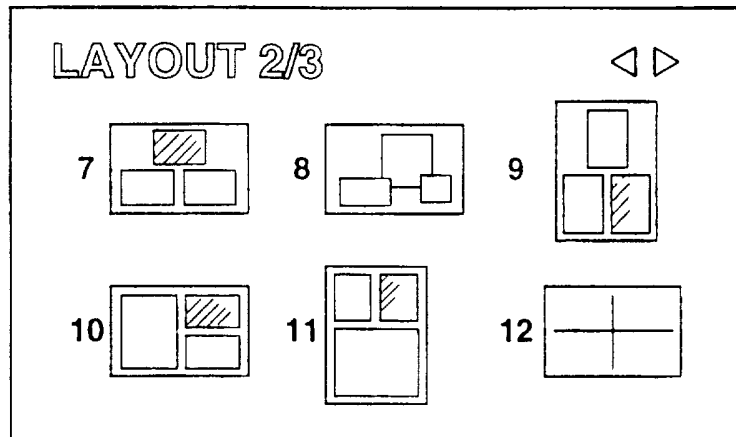


FIG.15C

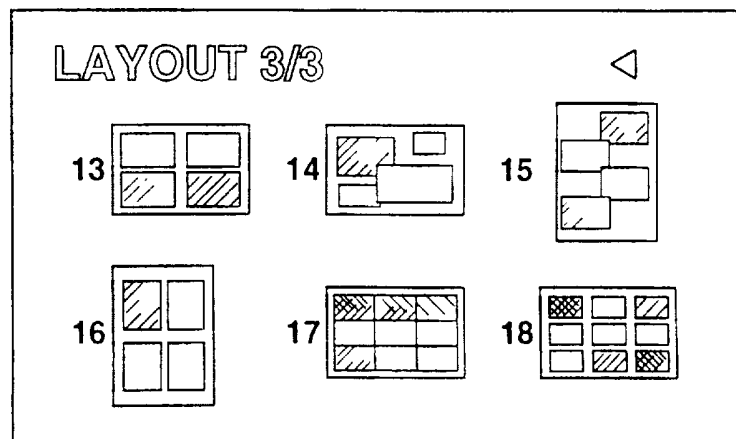


FIG.16

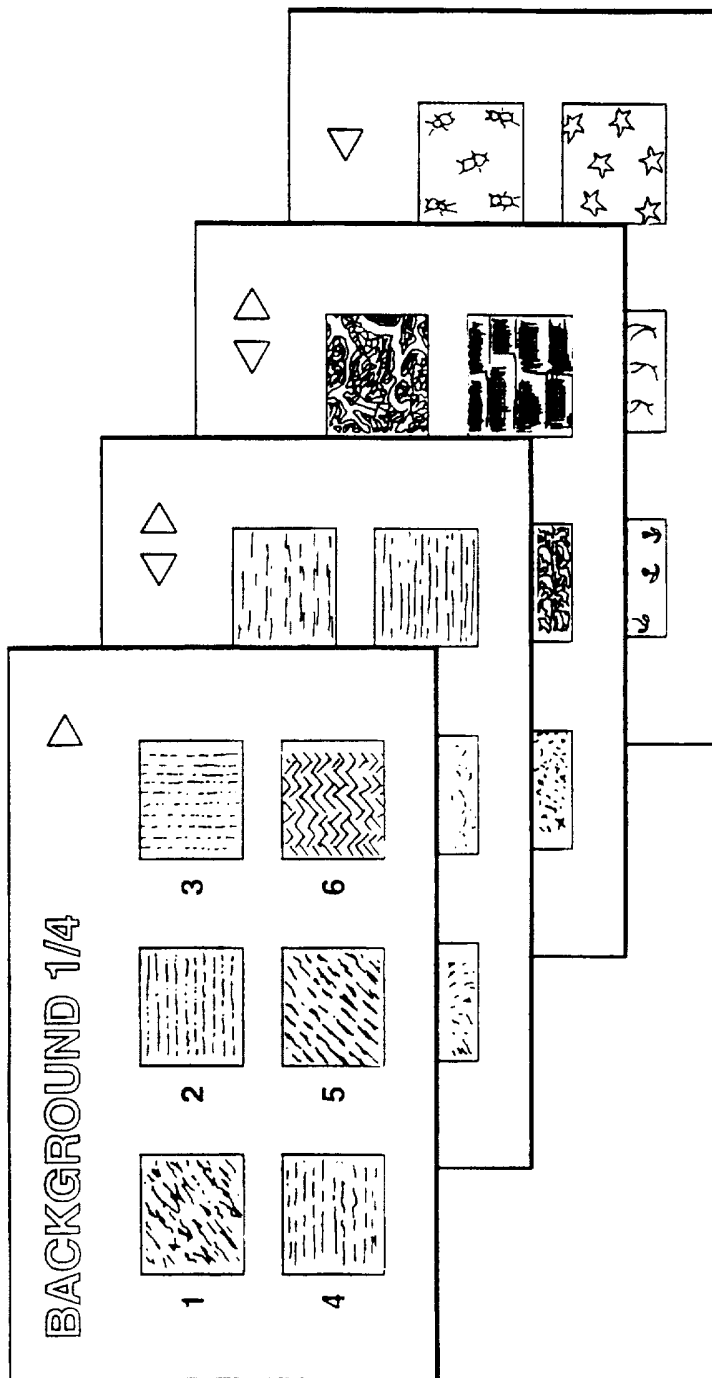
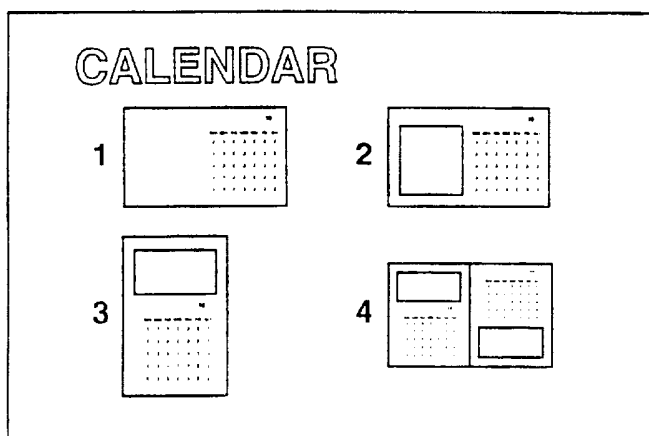


FIG.17



17/31

FIG.18A

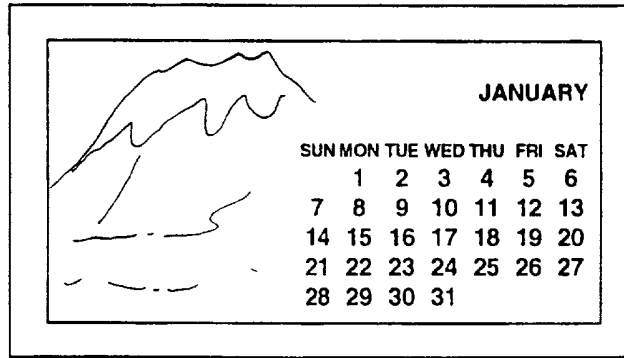


FIG.18B

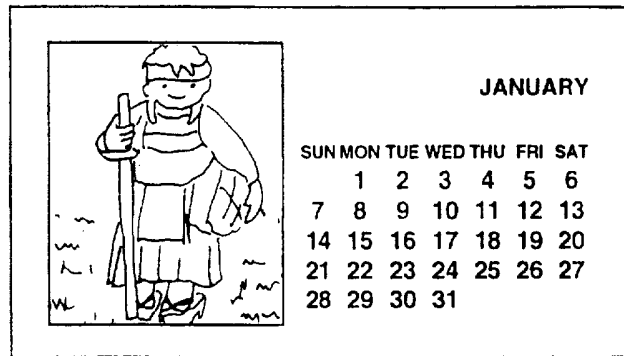


FIG.18C

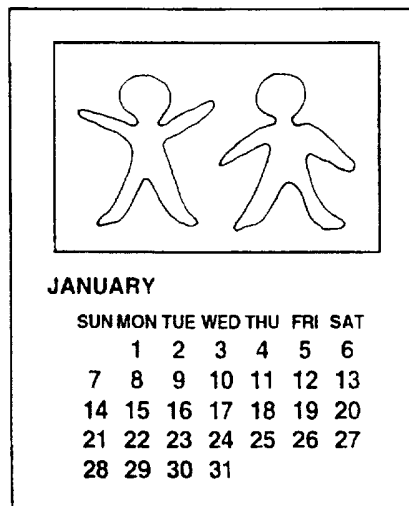


FIG.19A

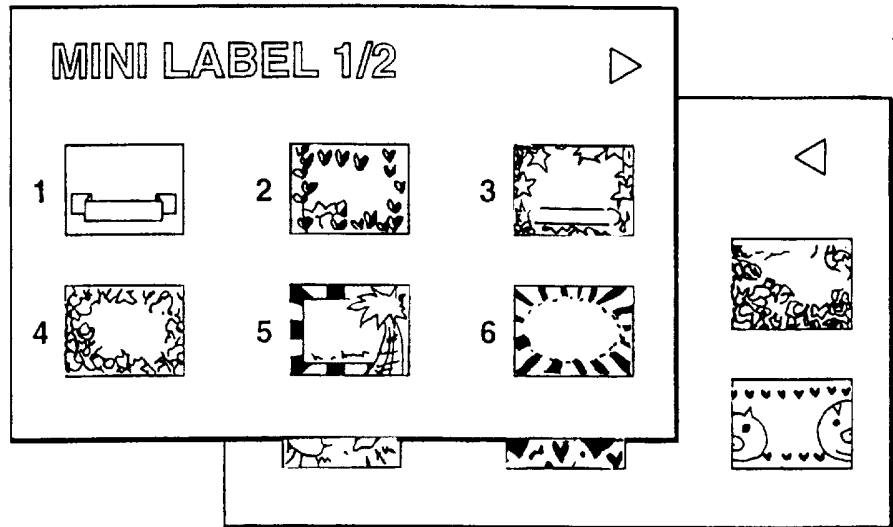


FIG.19B

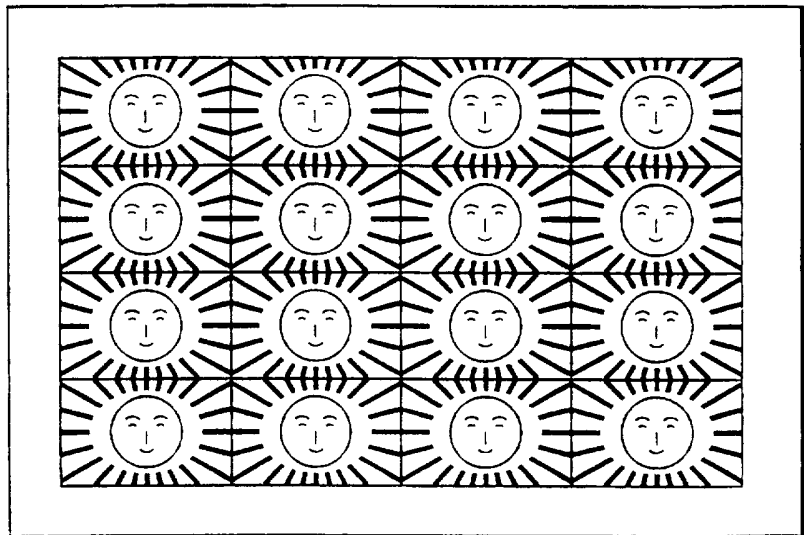


FIG.20A

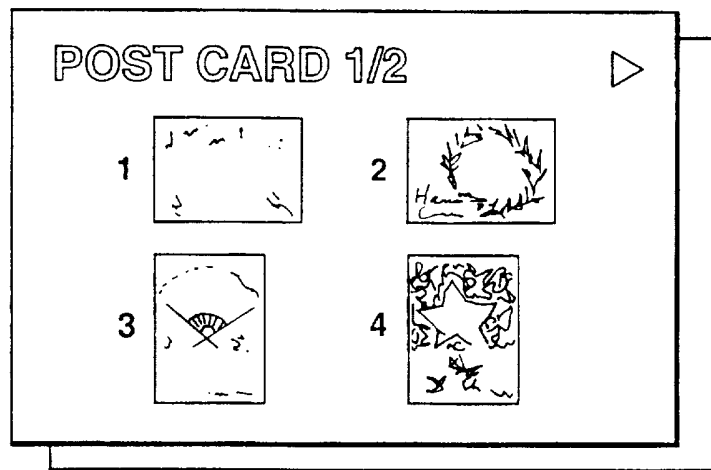
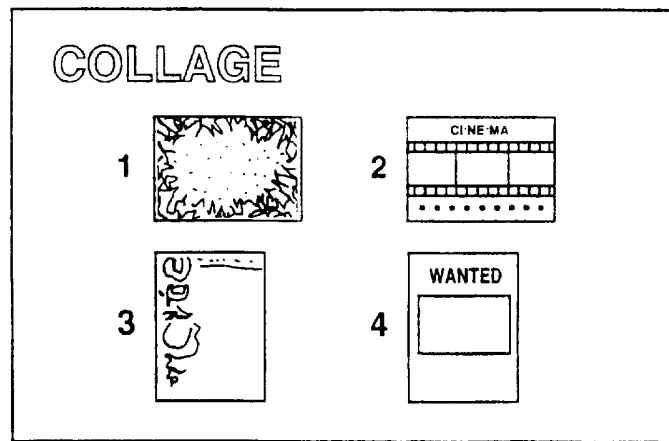


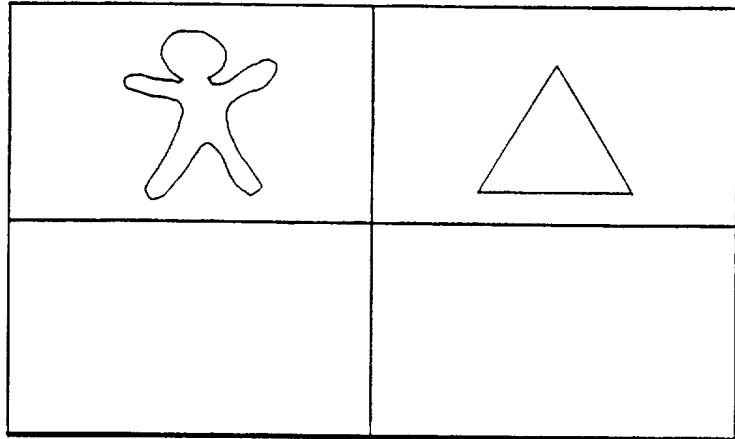
FIG.20B



20/31

2 TO 4 IMAGES

FIG.21A



5 TO 9 IMAGES

FIG.21B

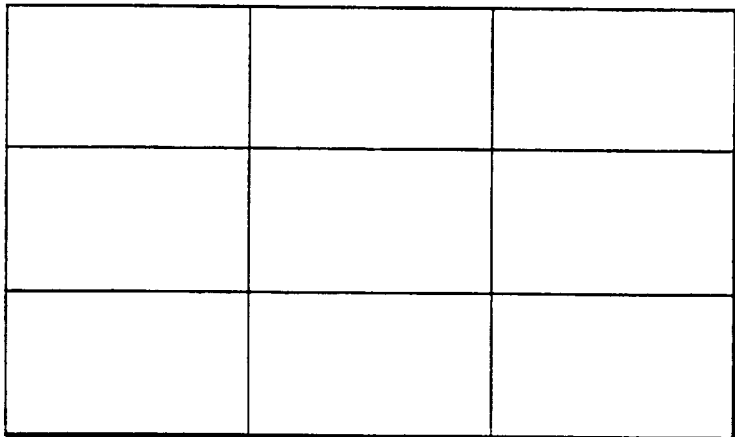


FIG.21C

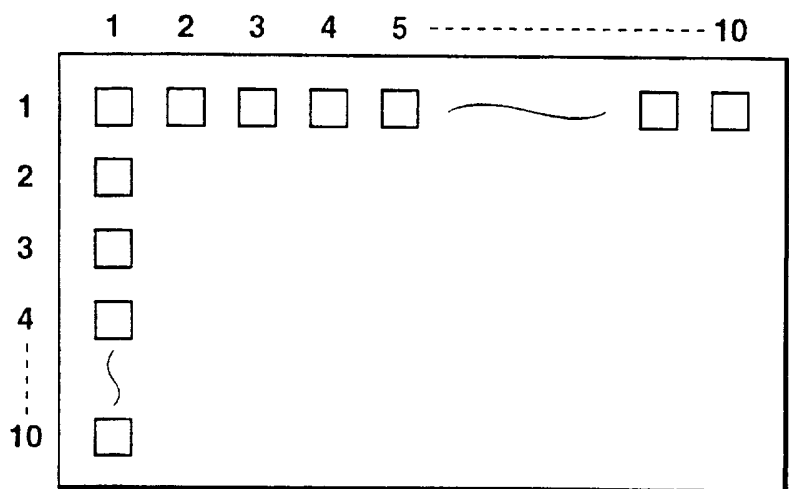






FIG.23

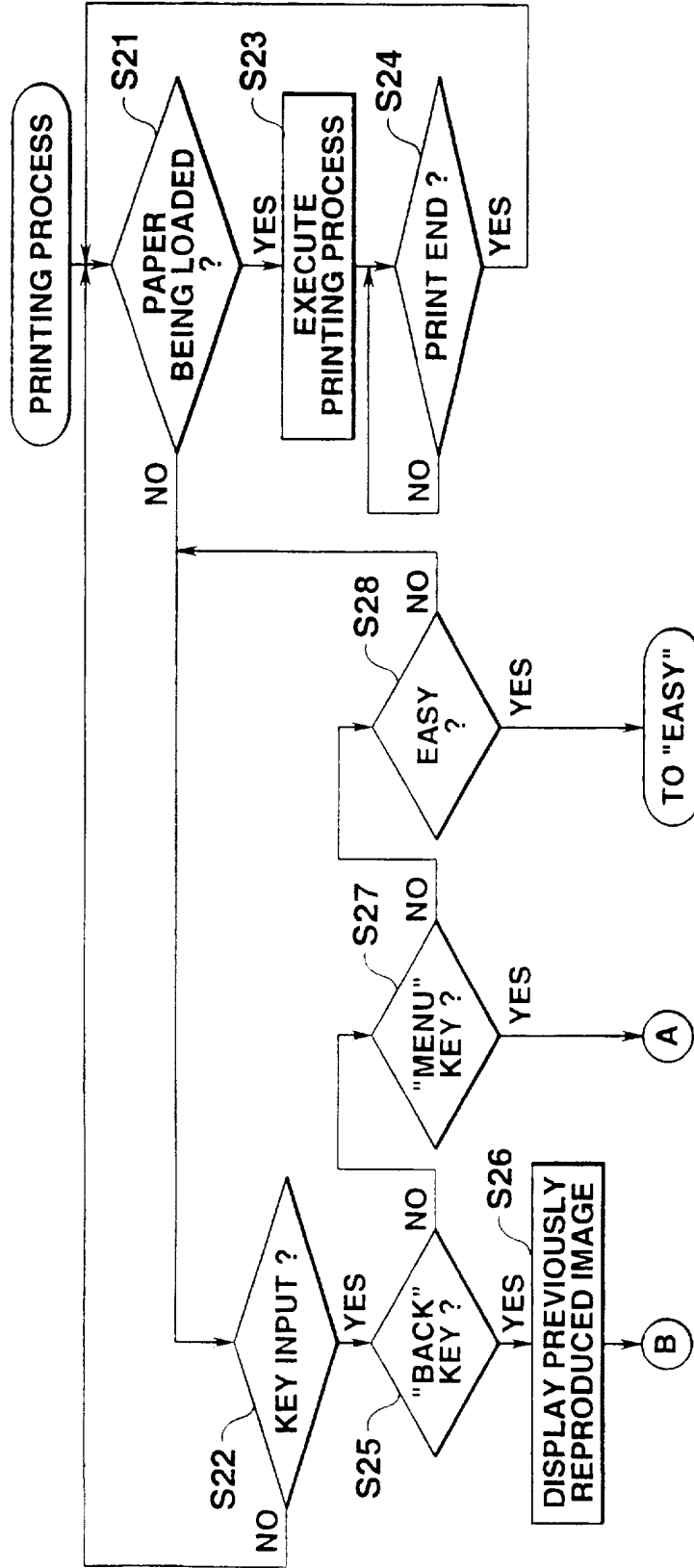


FIG.24

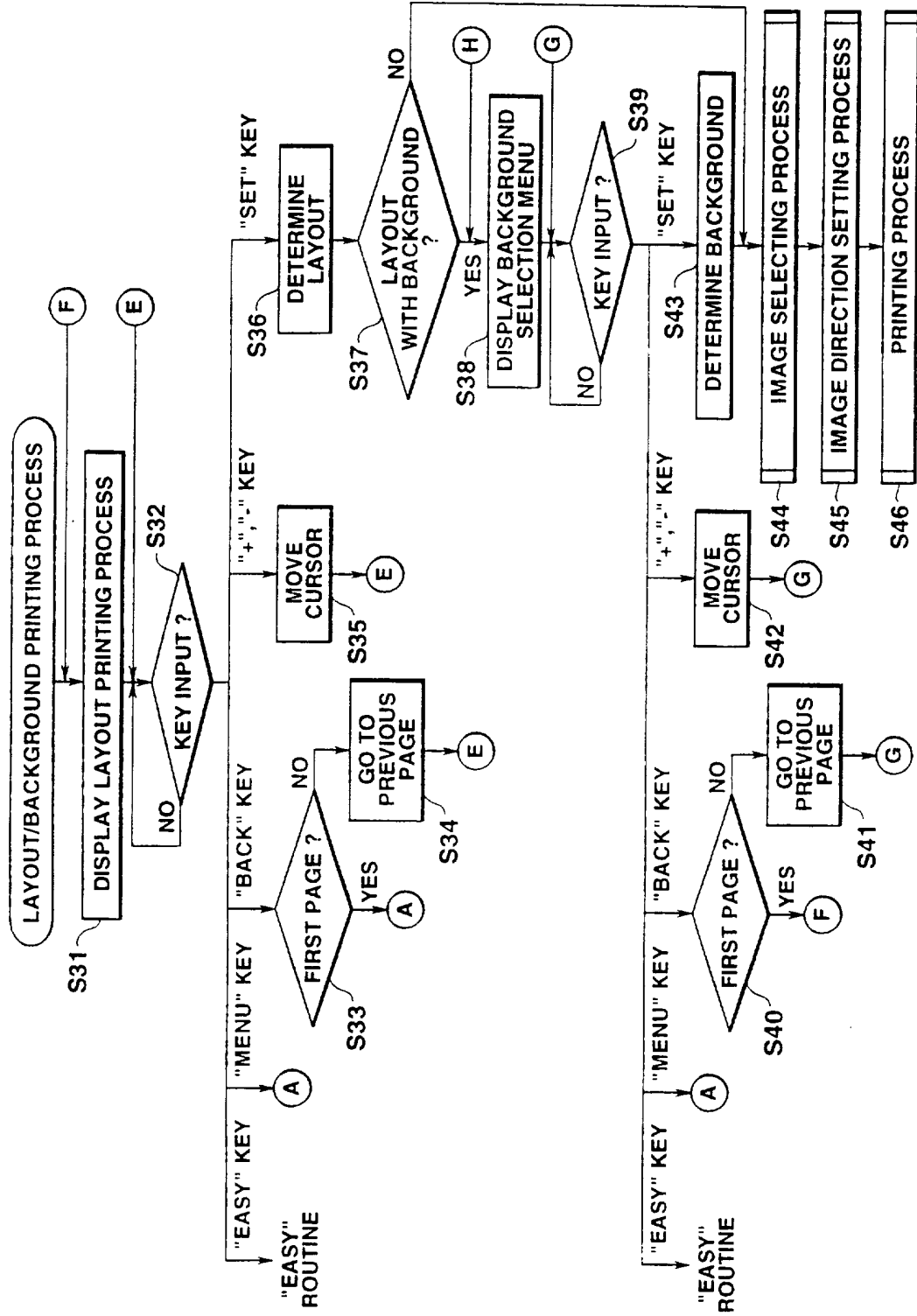




FIG.26

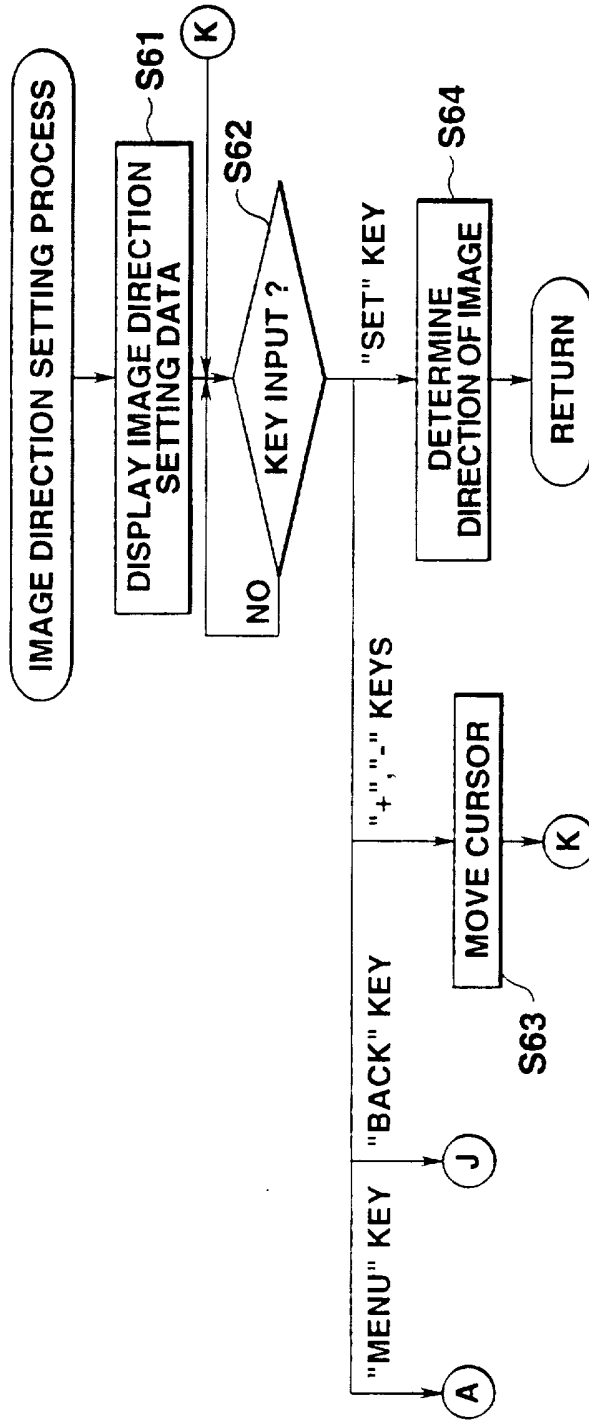


FIG.27

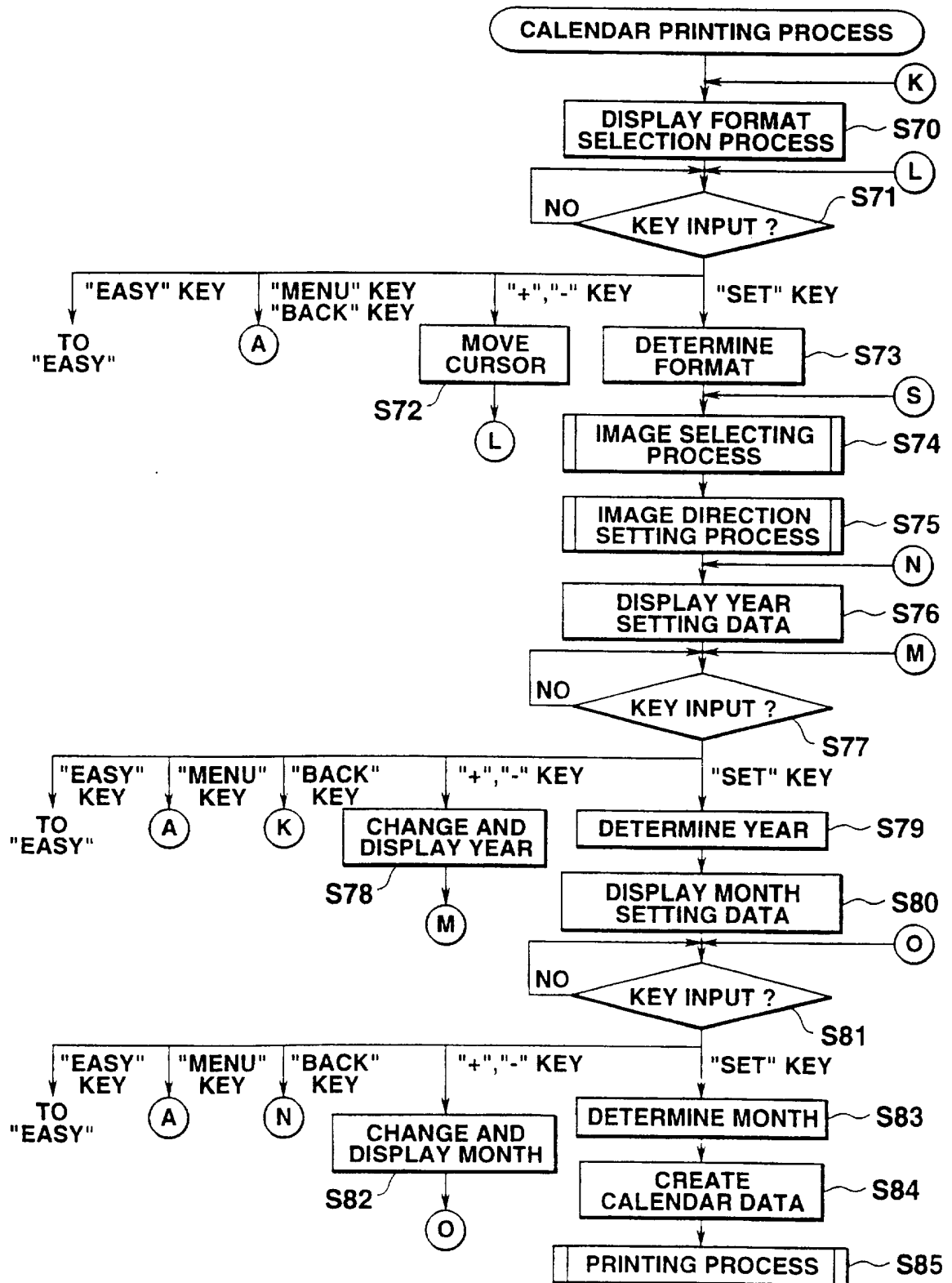


FIG.28

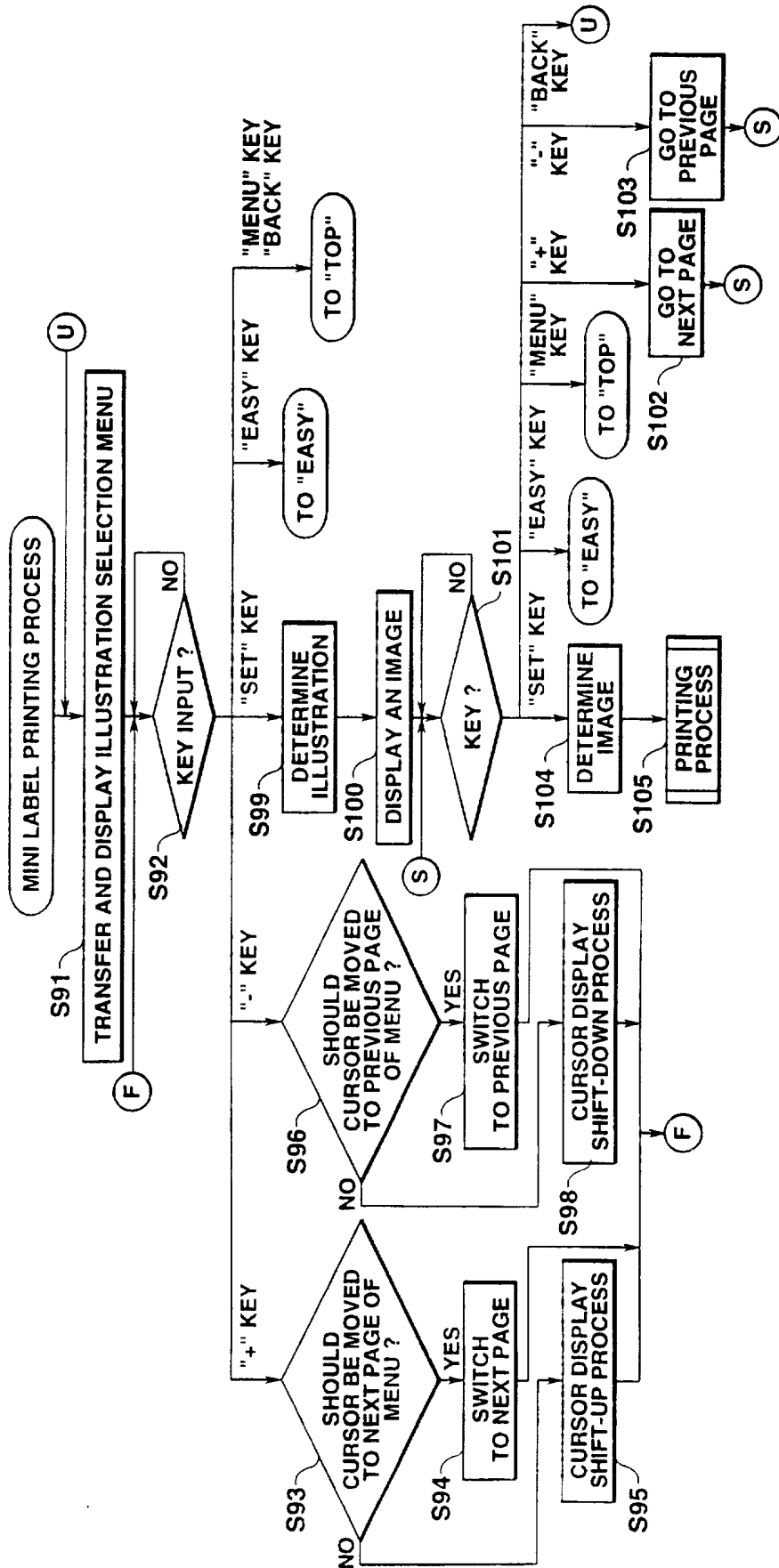


FIG.29

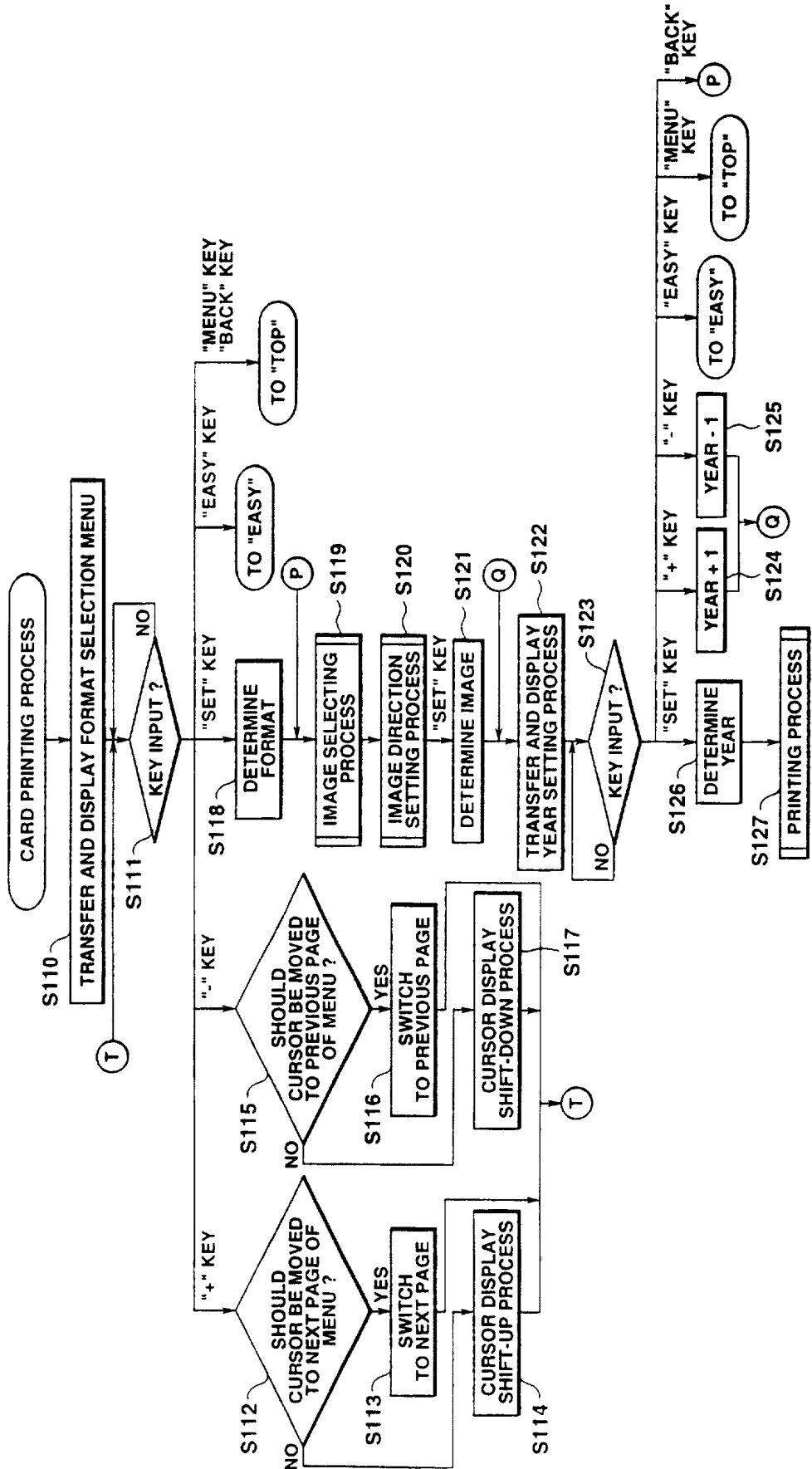




FIG.30

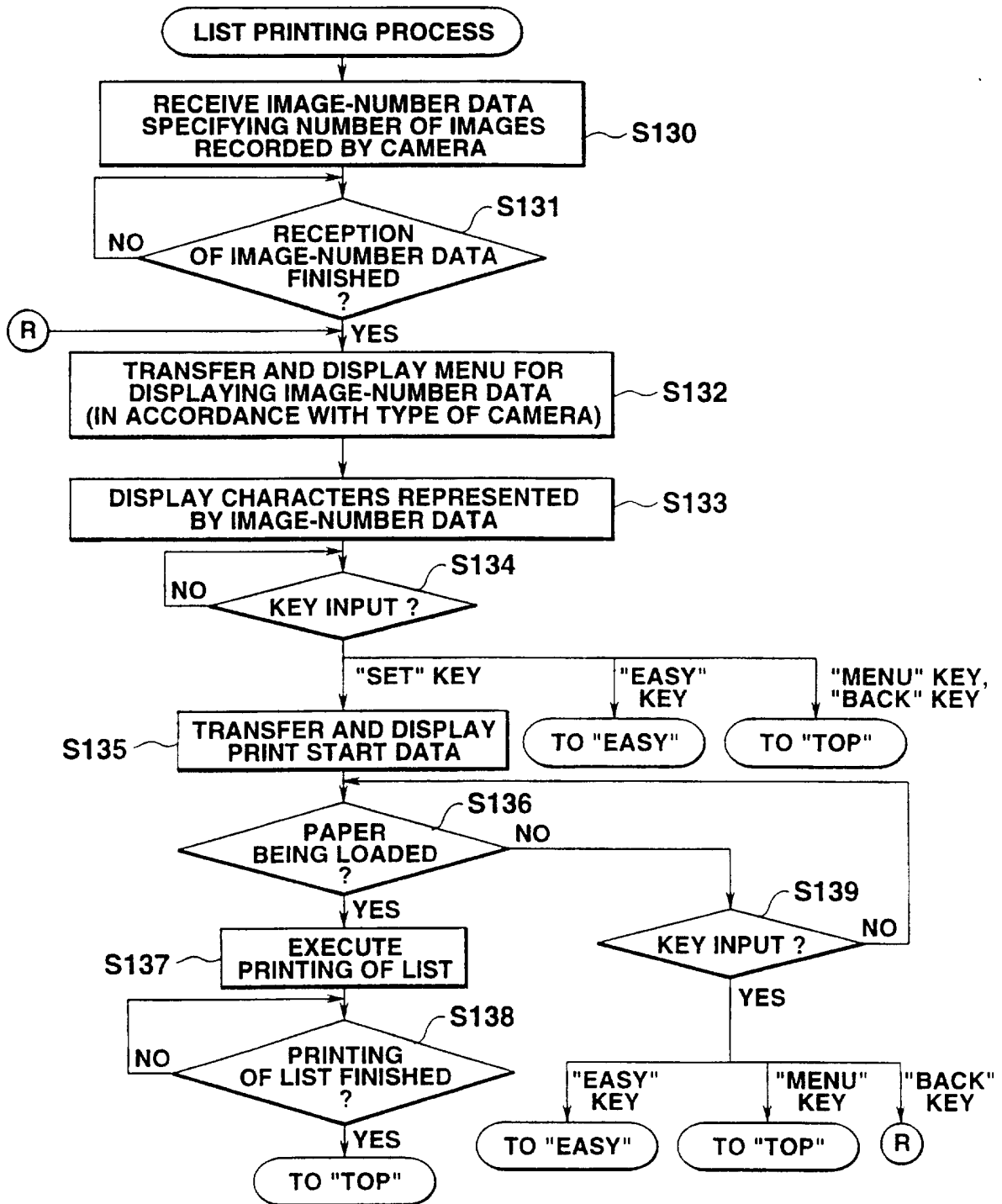


FIG.31A

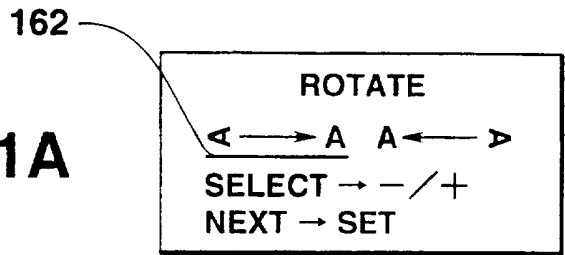


FIG.31B

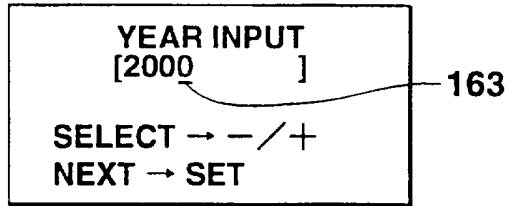
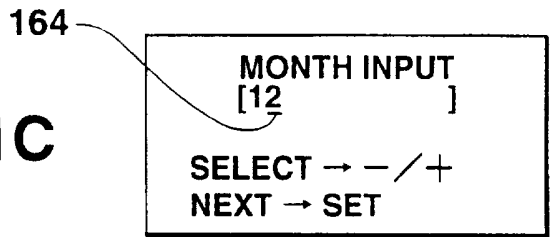


FIG.31C



**FIG.32A**

INDEX PRINT  
NORMAL \* \* \* PAGES  
FINE \* \* PAGES  
OK → SET  
EXIT → MENU

**FIG.32B**

INDEX PRINT  
\* \* PAGES  
OK → SET  
EXIT → MENU

**FIG.32C**

PRINT  
■  
YES → LOAD PAPER  
NO → MENU

# INTERNATIONAL SEARCH REPORT

Internat. Application No  
PCT/JP 97/02148

A. CLASSIFICATION OF SUBJECT MATTER  
IPC 6 H04N1/00

According to International Patent Classification (IPC) or to both national classification and IPC

B. FIELDS SEARCHED

Minimum documentation searched (classification system followed by classification symbols)  
IPC 6 H04N

Documentation searched other than minimum documentation to the extent that such documents are included in the fields searched

Electronic data base consulted during the international search (name of data base and, where practical, search terms used)

C. DOCUMENTS CONSIDERED TO BE RELEVANT

Category *	Citation of document, with indication, where appropriate, of the relevant passages	Relevant to claim No.
A	WO 92 11731 A (EASTMAN KODAK) 9 July 1992 see abstract; figures ---	1
A	GB 2 242 592 A (PHOTO-ME INTERNATIONAL) 2 October 1991 see abstract; figures ---	1
A	EP 0 326 515 A (ALPORT HOLDING) 2 August 1989 see abstract; figure 1 ---	1
A	US 5 301 036 A (BARRETT ET AL) 5 April 1994 see abstract; figure 11 see column 10, line 8 - line 26 -----	1

Further documents are listed in the continuation of box C.

Patent family members are listed in annex.

\* Special categories of cited documents :

- \*A\* document defining the general state of the art which is not considered to be of particular relevance
- \*E\* earlier document but published on or after the international filing date
- \*L\* document which may throw doubts on priority claim(s) or which is cited to establish the publication date of another citation or other special reason (as specified)
- \*O\* document referring to an oral disclosure, use, exhibition or other means
- \*P\* document published prior to the international filing date but later than the priority date claimed

- \*T\* later document published after the international filing date or priority date and not in conflict with the application but cited to understand the principle or theory underlying the invention
- \*X\* document of particular relevance; the claimed invention cannot be considered novel or cannot be considered to involve an inventive step when the document is taken alone
- \*Y\* document of particular relevance; the claimed invention cannot be considered to involve an inventive step when the document is combined with one or more other such documents, such combination being obvious to a person skilled in the art.
- \*&\* document member of the same patent family

Date of the actual completion of the international search

16 September 1997

Date of mailing of the international search report

29. 09. 97

Name and mailing address of the ISA

European Patent Office, P.B. 5818 Patentlaan 2  
NL - 2280 HV Rijswijk  
Tel. ( + 31-70) 340-2040, Tx. 31 651 epo nl,  
Fax: ( + 31-70) 340-3016

Authorized officer

Isa, S

# INTERNATIONAL SEARCH REPORT

Information on patent family members

International Application No <b>PCT/JP 97/02148</b>
--

Patent document cited in search report	Publication date	Patent family member(s)	Publication date
WO 9211731 A	09-07-92	EP 0522132 A	13-01-93
GB 2242592 A	02-10-91	NONE	
EP 326515 A	02-08-89	CA 1319973 A CH 675804 A	06-07-93 31-10-90
US 5301036 A	05-04-94	NONE	