

*D. J. Farmer*

*Land & Water Velocipede.*

*N<sup>o</sup> 92,807.*

*Patented Jul. 20, 1869.*

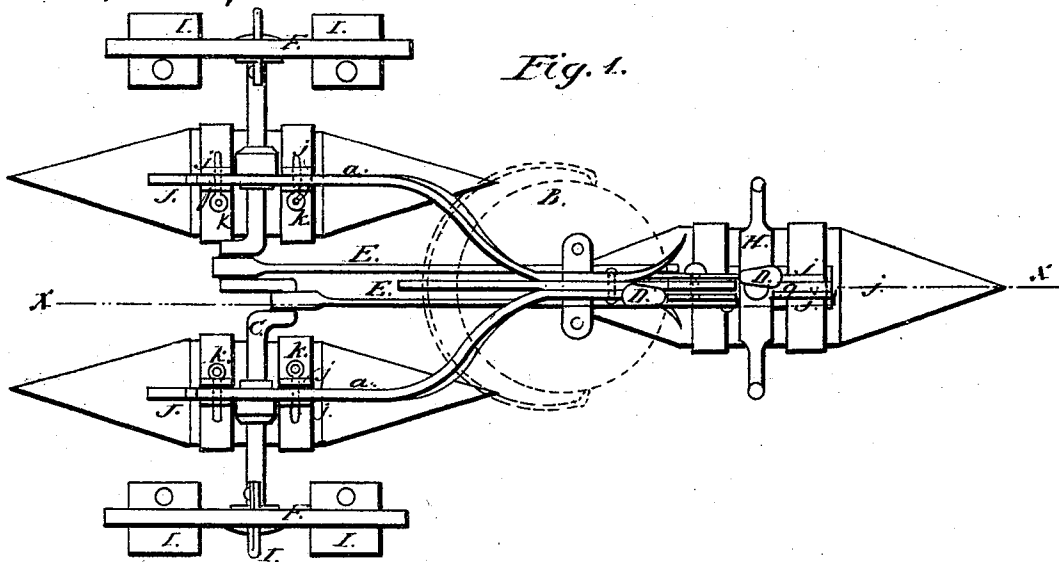

*Fig. 1.*

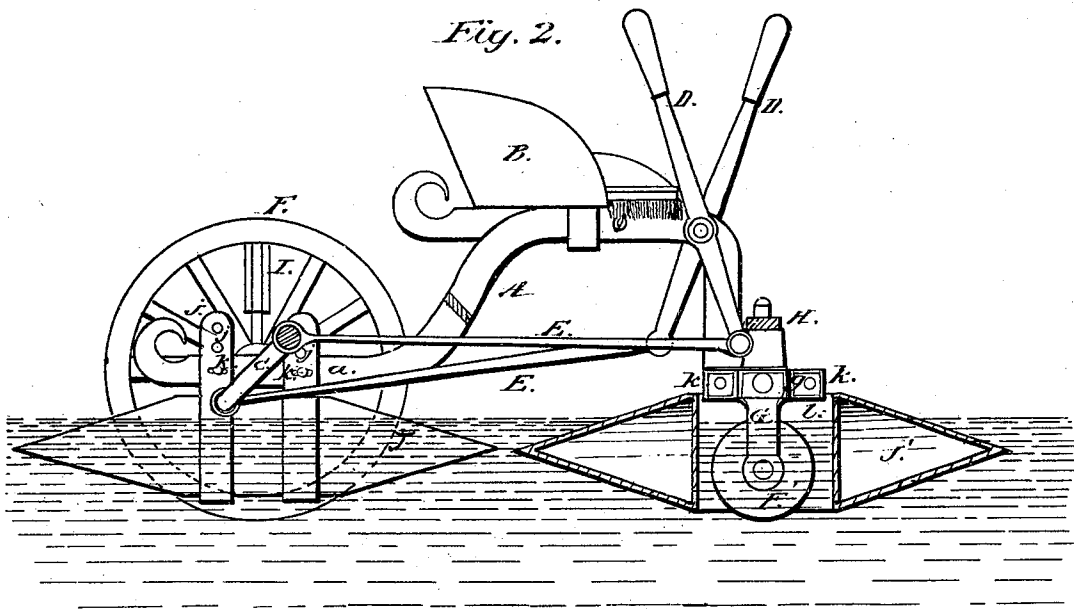

*Fig. 2.*

*Witnesses;*  
*W. B. Deming*  
*John Grinnell*

*Twenty*  
*D. J. Farmer*  
*by Knight-Brogue*  
*Attorneys*

# United States Patent Office.

DAVID J. FARMER, OF WHEELING, WEST VIRGINIA.

Letters Patent No. 92,807, dated July 20, 1869.

## IMPROVEMENT IN LAND AND WATER-VELOCIPED.

The Schedule referred to in these Letters Patent and making part of the same.

To all whom it may concern :

Be it known that I, DAVID J. FARMER, of Wheeling, in the county of Ohio, and State of West Virginia, have invented a new and useful Improved Land and Water-Velocipede; and the following is a sufficiently full, clear, and exact description, to enable one skilled in the art to which my invention appertains, to carry it into effect, reference being had to the accompanying drawings, which are made part of this specification.

My invention relates to an improved construction of velocipedes, or the provision therein of certain parts, to adapt them to be readily converted for use either on land or water, said parts being adapted to be removed, or so adjusted as to be out of the way when not required for use.

My improvements consist in a novel construction and arrangement of floats for supporting the vehicle on the water, and in the adaptation of said floats to be adjusted to support the vehicle a greater or less height above the surface of the water as required, and to be removed when not in use; and in the employment, in combination with said arrangement of removable floats, of wheels, adapted to be converted to form draught or paddle-wheels, as required.

In the drawing, a velocipede illustrating my invention is represented as used on the water—

Figure 1 being a plan view, with the seat removed, and its position indicated by dotted lines, and

Figure 2, a vertical section on the line *x x*, fig. 1.

A may represent the frame or perch;

B, the seat;

C, the crank-axle;

D D, the propelling-levers;

E E, the connecting-rods, connecting the levers D and the wrists of the axle C;

F F, the rear or driving-wheels;

F', the front or steering-wheel;

G, the swivelled standard of the wheel F'; and

H, the treadles or cross-head of said standard G, all of which parts may be of any preferred suitable form and arrangement.

I I represent blades or wings, which—of suitable form, material, and relative size—are applied to the driving-wheels F F, to adapt said wheels to act as propellers, said blades or wings being swivelled on the spokes of the wheels, as shown, or otherwise attached thereto, and in any sufficient number.

J J J' are floats, attached respectively at the rear and front ends of the frame A, to support the vehicle in the water, being of the requisite size, of any usual or suitable material or construction, and arranged substantially as represented in fig. 1.

Said floats are attached preferably by pairs of perforated ears or flanges *j j*, on their upper sides, adapted

to receive between them the wings or legs *a a* of the frame A, and a cross-bar, *g*, of the swivelled standard G, which, being correspondingly perforated, they are fastened to by transverse pins or keys *k*, passing through the perforations in each.

By the duplication of the perforations in the ears or flanges *j j*, as shown at *j*, fig. 2, the floats are adapted to be adjusted so as to vary the height they support the vehicle at, as desired.

Said ears or flanges may be the ends of bands or straps passing around the floats, as shown, or be attached thereto in other suitable manner.

The float J' is provided with a recess or cavity, *l*, for the reception of the guiding-wheel F', over which it is applied.

The vehicle provided as above described, placed in the water as represented in fig. 2, is supported by the floats J J'. By the blades or wings I, the rotation of the driving-wheels F is made to propel it; and, by the movement of the treadles H and front float, J', it is guided as readily as were it on land, which it is further adapted to run on with these provisions attached, as indicated by the red line in fig. 2.

By removing the floats J J', and folding the blades or wings I between the spokes of the wheels, or removing them, the vehicle is adapted, with minimum bulk, for running on land.

I propose attaching the equivalent of the wings or blades I, in the form of flanges, to the sides of the driving-wheels; also, providing the front float, J', with the same adjustment as the rear ones; also, employing, in connection with the provisions described, any suitable operating-mechanism, and a keel at the bottom of the front float, or a suitable rudder for steering when desired; also, arranging the rear floats F F, outside of the driving-wheels, if preferred.

Having thus described my invention, the following is what I claim as new, and desire to secure by Letters Patent:

1. I claim the floats J J J', arranged substantially as described, for the purpose set forth.

2. I claim the floats J J J', adapted to be adjusted as described, for the purpose set forth.

3. I claim the float J', constructed with the cavity or recess *l*, as represented and described, for the purpose set forth.

4. In combination with the removable floats J J J', arranged as described, the combined draught and paddle-wheels F F, constructed as represented and described, for the purpose set forth.

DAVID J. FARMER.

Witnesses:

JOHN P. FARMER,

WM. H. HOBBS.