

Sept. 25, 1945.

G. F. SEASHORE

2,385,654

WRENCH

Filed May 5, 1943

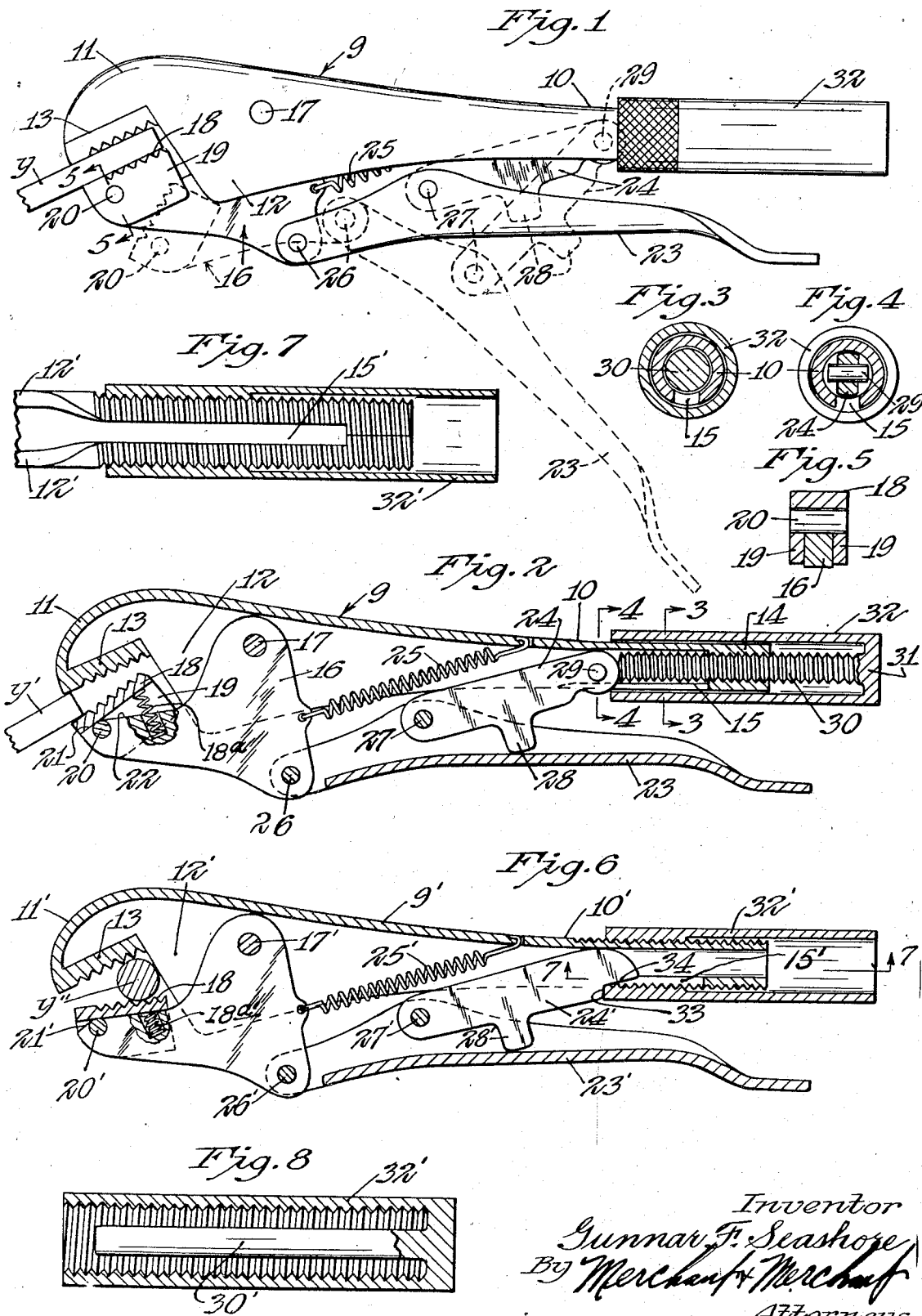

Inventor  
Gunnar F. Seashore  
By Merchant & Merchant  
Attorneys

# UNITED STATES PATENT OFFICE

2,385,654

WRENCH

Gunnar F. Seashore, Minneapolis, Minn.

Application May 5, 1943, Serial No. 485,717

1 Claim. (Cl. 81-94)

My present invention belongs to the wrench art.

One phase of the invention pertains to improvements in the gripping jaws of hand wrenches, and has as an important objective the provision of an improved jaw construction whereby the gripping faces of the cooperating jaws will adapt themselves to engage flat surfaces of gripped objects regardless of whether the engaged flat surfaces be parallel or flaring. In accordance with the invention, this and other important objectives are arrived at by providing one of the relatively movable jaws with a movable gripping plate that is anchored therethrough for limited pivotal movements. In the preferred embodiment of the invention illustrated, the wrench jaws are pivotally connected for swinging movements toward and from one another and, of course, the invention is particularly advantageous when used in connection with this pivoted jaw construction in that the pivoted gripping plate on one of the jaws will move under gripping action and adjust itself to compensate for variations in angularity between the gripping faces of the jaws caused by pivotal opening and closing movement thereof one with respect to the other. In the case of the pivoted jaw construction, the movable gripping plate is preferably anchored to the pivotally movable of the jaws on an axis parallel to but spaced from the jaw pivot. Preferably, the movable jaw plate is pivotally anchored to its respective jaw by a pivot located considerably outwardly of the longitudinal center of the pivoted jaw plate, and, in many respects, it has been found that best results can be expected when the pivot is spaced from the inner end of said jaw plate a distance approximately equalling  $\frac{3}{4}$  of the total length of the pivoted jaw plate. Also, in the preferred embodiment of the invention illustrated, pivotal movements of the jaw plate are definitely limited in two directions, and the said pivoted jaw plate is spring pressed toward an outwardly flaring relationship with the gripping face of the cooperating jaw. Other advantages of this construction are efficient gripping at the extreme ends of the jaw and the ability to withstand greater stresses when so used; and efficient gripping action on pipes and the like engaging the gripping faces of the jaws only inwardly of the pivot of the movable jaw plate.

Another phase of the invention is confined to wrenches of the type wherein the movable jaw of the wrench is operated through the medium of toggle linkage comprising a stub link having

its fulcrum at longitudinally adjustably selected portions along the linkage. This phase of the invention has as its main object to provide improved handle and fulcrum portion adjusting means for wrenches of this general character.

The above and other important objects and advantages of the invention will be made apparent from the following specification, claim, and appended drawing.

In the accompanying drawing, like characters indicate like parts throughout the several views. Referring to the drawing:

Fig. 1 is a view in side elevation of a wrench embodying the present invention;

Fig. 2 is a sectional view taken through the longitudinal axis of the wrench illustrated in Fig. 1;

Fig. 3 is a detail sectional view taken on the line 3-3 of Fig. 2;

Fig. 4 is a detail sectional view taken on the line 4-4 of Fig. 2;

Fig. 5 is a detail sectional view taken on the line 5-5 of Fig. 1;

Fig. 6 is a sectional view similar to Fig. 2, but showing a modification of the wrench handle and stub lever fulcrum adjusting means;

Fig. 7 is an enlarged detail sectional view taken on the line 7-7 of Fig. 6, some parts being removed and some parts being broken away; and

Fig. 8 is an enlarged sectional view showing a still further modification of the invention as pertains to the fulcrum adjusting means for the stub link of the toggle.

With reference first to Figs. 1-5 inclusive, the numeral 9 indicates, as an entirety, a lever involving a handle 10 and a jaw 11, which may hereinafter be referred to as a fixed jaw. The lever 9 may be assumed to be pressed from sheet metal, but may, of course, be otherwise formed, and at its intermediate portion and jaw end is shaped to provide a downwardly-opening channel having spaced parallel side flanges 12. Extending between the spaced parallel flanges 12 at the free end of the jaw 11 is a hardened gripping plate 13 having suitable teeth in its gripping surface. The gripping plate 13 may be assumed to be welded or otherwise rigidly anchored to the jaw 11. To form the handle portion 10 of the lever, the flanges 12 thereof are bent into circular formation to provide a completely circular tubular part 14 at the extreme rear end part of the handle and a somewhat incomplete slotted tubular part forwardly of the completely tubular part 14. As will be seen particularly by reference to Fig. 7, the slot, indicated by 15, in

the incompletely tubular handle 10 is in the bottom thereof and opens into the wider channel portion between the flanges 12 at the intermediate portion of the lever 9.

The movable jaw 16 of the wrench of Figs. 1-5 inclusive is shown as being of solid form such as attained by casting or drop forging and is pivotally anchored to and between the flanges 12 of the lever 9 by a riveted pivot pin 17. At its free end portion, and for cooperation with the toothed jaw plate 13 of the fixed jaw, the said movable jaw 16 is equipped with a toothed movable gripping plate 18 which, like the jaw 13, is formed of suitable hardened steel. This movable gripping plate 18 of the pivotally movable jaw 16 is integrally formed with laterally spaced depending anchoring flanges 19 that overlap the sides of the pivotally movable jaw 16 and have close-fitting sliding engagement therewith to thereby prevent lateral movements thereon in respect to the jaw 16. The pivotal anchoring of the movable gripping plate 18 to the movable jaw 16 is accomplished by passing a pivot pin 20 through the spaced flanges 19 and jaw 16. As previously indicated, this pivot 20 is located outwardly of the longitudinal center of the gripping plate 18, and preferably is spaced from the inner end of the plate about  $\frac{3}{4}$  of its length. Also, for best results, the axis of the pivot 20 should be located as close as practical to the gripping face of the plate 18 and in this connection it will be seen, by reference to Fig. 2, that the bore in the jaw 16 receiving the pivot pin 20 opens slightly through the face of the jaw adjacent the plate 18, so that the under side of the plate 18 is substantially in contact with an exposed portion of the pin 20. Outwardly of the pivot pin 20 the jaw 16 is formed with a flat surface 21 for limiting pivotal movements of the gripping plate 18 in one direction, and inwardly of the pivot 20 the jaw 16 is formed with a flat stop surface 22 for limiting pivotal movements of the gripping plate 18 in the other direction; one extreme position of the gripping plate 18 being shown in Fig. 2 and another extreme position thereof being shown in Fig. 6, later to be described, but wherein the jaw construction is retained.

The spring for yieldingly pressing the pivoted gripping plate 18 toward its extreme portion shown in Fig. 2 is indicated by 18a and is of the coil compression type; this spring being seated at one end in a suitable bore in the jaw 16 and reacting at its other end against the under surface of the plate 18 between the flanges 19.

For operating the movable jaw 16, there is provided an operating mechanism comprising a lever 23, a suitable lever or link 24, and a coil tension spring 25. The spring 25 is anchored at one end to the lever 10 and at the other end to the jaw 16, and urges the parts toward their jaw open positions. The lever 23 underlies the lever 9 and is formed at its rear end with a handle-acting portion for cooperation with the handle 10. At its front end, the lever 23 is pivoted to the jaw 16 at a point 26 well spaced from the pivot 16, and the stub lever or link 24 is pivotally connected to the intermediate portion of the lever 23 at 27 to form with said lever a toggle operated by the rear or handle portion of the lever 23. To stop inward jaw cooperating movement of the lever 23 just after the toggle has passed its dead center portion, the stub link or lever 24 is provided at its intermediate portion with a stop lug 28 for engagement with the intermediate portion of the lever 23. The rear or other end of the

stub toggle lever or link 24 works in the slotted handle 10 of the lever 9 and, in the construction shown in Figs. 1-5 inclusive, is retained against accidental displacement from the slot 15 by a pin 29. In Figs. 1-5 inclusive, the rear or free end of this stub toggle lever 24 finds its base of reaction against the inner end of a screw-threaded shank 30 that has screw-threaded engagement with and works through the completely tubular portion 14 of the handle 10. The shank 30 is welded or otherwise anchored at 31 to and forms an integral part of a tubular hand grip 32. The tubular hand grip 32 works telescopically over the cylindrical handle portion 10 of the lever 9. With this construction, the fulcrum point of the rear or outer portion of the stub toggle lever 24 is adjustable longitudinally of the lever 9 by merely rotating the tubular hand grip 32 to thereby adjustably shift the location of the base of reaction of the lever 24, and this can be done most conveniently without removing the operator's hand from a lever-squeezing position on the tubular hand grip 32 of the lever 9. In this connection, it will, of course, be understood that the tubular hand grip 32 covers that portion of the handle 10 of lever 9 which is gripped by the operator when applying clamping pressure by the levers 9 and 23.

It should be apparent that movement of the lever 28 from its dotted line position of Fig. 1 to its full line position of Fig. 1 will cause the pivotally movable jaw 16 to move from its open inoperative position shown by dotted lines in Fig. 1 to its full line operative position of Fig. 1. Furthermore, it would appear to be evident that the position of the fulcrum point of toggle lever or arm 24 by means of the tubular hand grip 32 and its shank portion 30 is valid to accommodate work pieces of different thickness, the position of the shank 30 in Figs. 1 and 2 being as required to accommodate the work piece *y* shown in Fig. 1. Furthermore, it will be obvious by reference particularly to Figs. 1 and 2 that the knee portion of the toggle linkage moves slightly past dead center in a closed position of the levers 9 and 23 so as to automatically lock the wrench jaws in clamped relation on the work.

In the modification shown in Fig. 8, variable adjustment of the fulcrum point of lever 24' is accomplished through the medium of a hand grip 32' having a shank 30', but in Fig. 8 the tubular hand grip 32' is internally threaded and is assumed to have threaded engagement with the exterior of the handle portion 10' of the lever 9', while the shank 30' is devoid of threads and is assumed to merely slide through the tubular portion 14' of the handle 10'.

For the purpose of simplicity, all parts in Figs. 6, 7, and 8, corresponding to parts in Figs. 1-5 inclusive or having the same general function will be assigned like characters plus the prime mark.

Now, with reference to Fig. 6, it will be seen that the tubular hand grip 32' is screw-threaded onto the handle 10' of lever 9' just as in Fig. 8, but is devoid of any shank portion such as 30 of Fig. 2 or 30' of Fig. 8. In Fig. 6 it will be seen that the stub toggle link or lever 24' is notched to provide a shoulder 33 and a rearwardly extending tongue portion 34. In this form of the invention, the shoulder 33 of the link 24' reacts against the inner end of the tubular hand grip 32' and the tongue 34 of the link 24' overhangs the inner end portion of the tubular hand grip 32' to provide accidental displacement of the rear end of link 24' from the handle 10' through the slot 15' thereof.

Of course, in the forms shown in Figs. 6 and 7, the variable adjustment of the fulcrum point of line 24' is accomplished by rotation and screw-threaded action on hand grip 32' on the screw-threaded handle 10'.

By reference to the drawing, it will be apparent that the gripping plate will move on its pivot 20 to automatically provide parallel gripping of the gripping plates 13 and 18 with any flat surface object squeezed between the plates 13 and 18 and extending both forwardly and rearwardly of the pivot 20 thereof. Now, by reference particularly to Fig. 2, it will be seen that when a work piece  $y'$  is gripped between the free ends of the gripping plates 13 and 18 outwardly of the pivot 20 the gripping plate 18 will remain at rest against the flat stop surface 21, and the parts will function just as in the case of a wrench of similar construction but having conventional rigid gripping plates. Another advantage of the invention resides in the fact that when a work piece such as shown at  $y''$  in Fig. 6 is clamped between those portions of the gripping plates inwardly of the pivot 20', the pivoted gripping plate 18 is forced into position wherein the gripping plates 13 and 18 converge outwardly one with respect to the other and thereby lock the work piece  $y''$  therebetween and the outer edges of the flanges 12', thereby providing a highly effective pipe wrench.

In all figures, the movable gripping plate 18 is anchored to its respective jaw by a pivot having

its axis extending transversely of the direction of movement of the pivoted jaw and may be said to be mounted for pivotal or locking movements in the plane of movement of the pivoted or movable jaw.

What I claim is:

In a wrench, a relatively fixed jaw, a relatively movable jaw pivotally connected to the fixed jaw for swinging movements with respect thereto, one of said jaws having a relatively fixed gripping surface and the other thereof carrying a movable gripping plate having a gripping surface for cooperation with the gripping surface of the other jaw, said relatively movable gripping plate being pivoted to its respective jaw for rocking movements thereon in the plane of movement of the movable jaw, the axis of the pivot of the gripping plate being located outwardly of the rear end of the gripping plate by a distance approximately equal to  $\frac{3}{4}$  of the length of the gripping plate, the under surface of the gripping plate being relatively flat and the cooperating jaw being formed with substantially flat stop surfaces extending oppositely from said pivot and at an angle to each other for engagement with the said flat surface of the gripping plate, the said flat surfaces of the jaw being substantially tangent with the periphery of the gripping plate pivot, and the said flat surface of the gripping plate also being substantially tangent with the periphery of the said pivot.

GUNNAR F. SEASHORE.