

Sept. 3, 1935.

S. E. SLOCUM

2,013,078

CENTRIFUGAL PUMP

Filed March 16, 1933

2 Sheets-Sheet 1

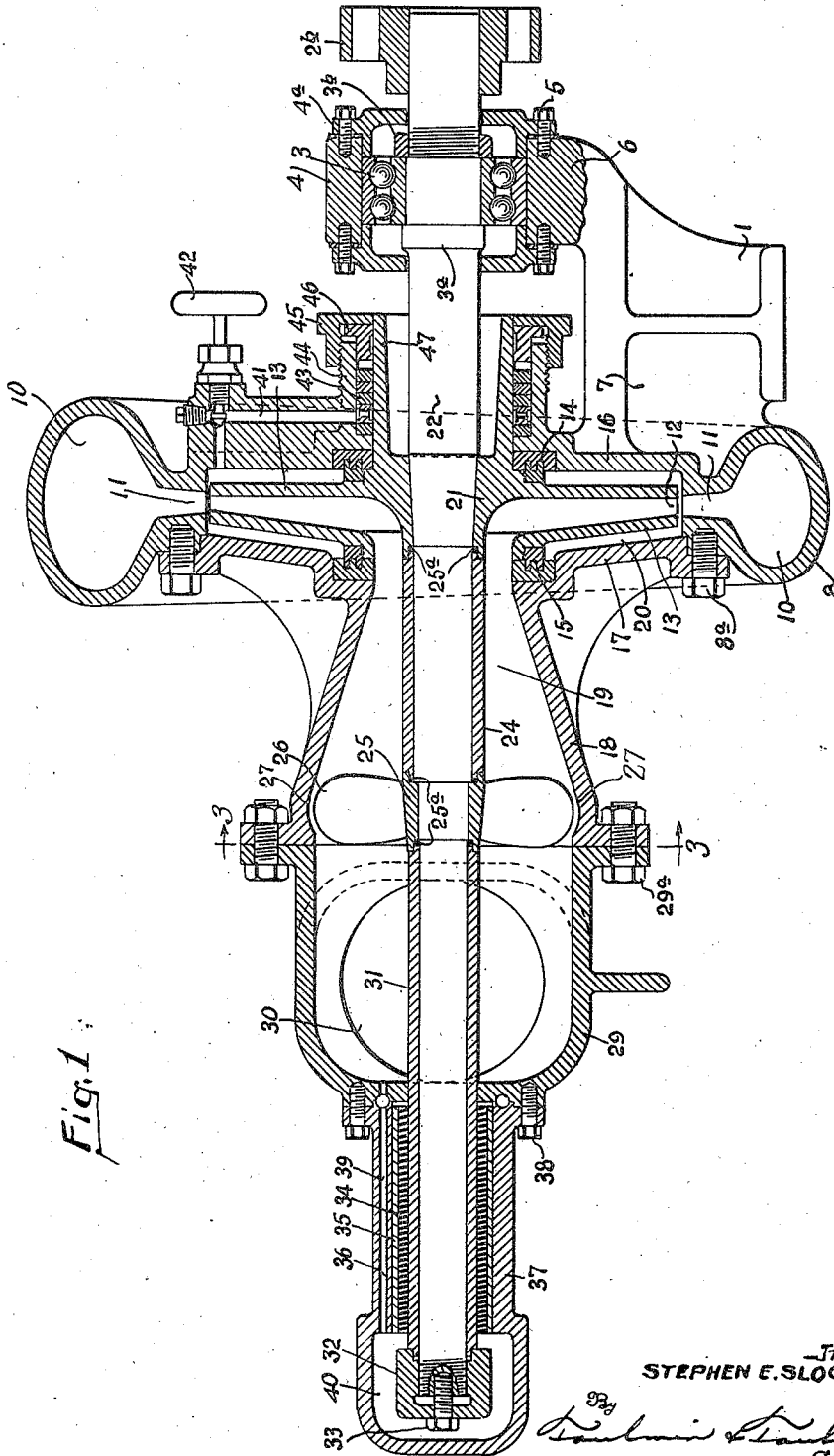

Fig. 1

Inventor.  
STEPHEN E. SLOCUM,

Pauline Slocum  
Attorneys

Sept. 3, 1935.

S. E. SLOCUM

2,013,078

CENTRIFUGAL PUMP

Filed March 16, 1933

2 Sheets-Sheet 2

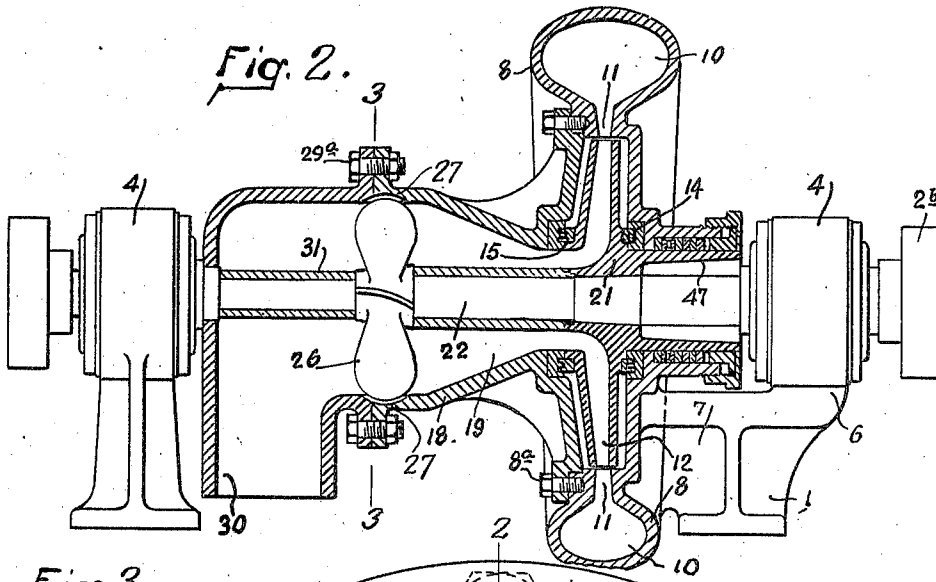

*Fig. 3.*

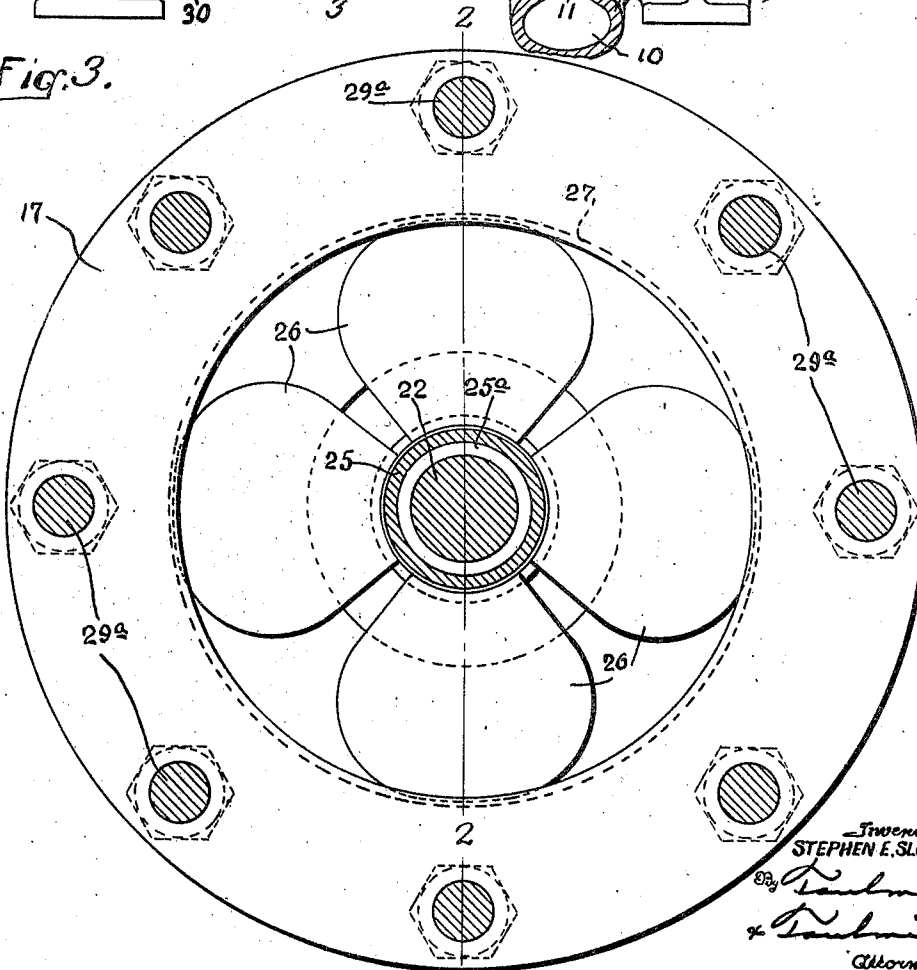

Inventor  
STEPHEN E. SLOCUM  
By Paulmier  
& Paulmier  
Attorneys

# UNITED STATES PATENT OFFICE

2,013,078

## CENTRIFUGAL PUMP

Stephen E. Slocum, Ardmore, Pa.

Application March 16, 1933, Serial No. 661,054

1 Claim. (Cl. 103—88)

This invention in general relates to a means for improving the performance of centrifugal pumps.

One object of the invention is to provide means for preventing retrograde movement of the fluid at the tips of the blades in a centrifugal pump of the propeller type.

Another object of the invention is to provide a centrifugal pump in which there is a two-stage handling of the fluid passing through the pump, the primary stage having a propeller for direct- in the fluid to the secondary stage, the tips of the propeller being set into a recess in the casing to impede retrograde movement of the fluid around them, the secondary stage having an impeller which expels the fluid at right angles centrifugally into the discharge passage.

In the drawings:

Figure 1 is a central longitudinal section through the centrifugal pump of my invention.

Figure 2 is a central longitudinal section through a modified form of pump with exterior bearings, taken along the line 2—2 of Figure 3.

Figure 3 is a transverse section along the line 3—3 of Figure 2.

Referring to the drawings in detail, 1 is a base upon the right-hand end of which is mounted a ball bearing 3 in the housing 4 mounted by the bolts 5 upon the base brackets 6.

This base is provided with a bracket 7 for supporting the volute delivery chamber wall 8, which chamber progressively increases in diameter towards the outlet. This progressively increasing volute space 10 communicates by a passageway 11 with the peripheral outlets 12 of the centrifugal impeller 13 which is supported by the bearing members 14 and 15 on either side. The bearing member 14 rests within the wall 16 which forms one side of a pump casing and is an extension of the volute chamber wall 8. Bolted to the volute chamber wall 8 is the wall 17 of an intermediate casing which forms the other side of the pump casing and supports the bearing 15. The intermediate casing has converging cone-shaped walls 18 forming a Venturi inlet passageway 19 that communicate with the radial passageways 20 of the impeller 13. The impeller 13 has a hub 21 mounted upon the shaft 22 which is supported in the bearing 3 and is driven by the coupling 2<sup>b</sup>. Mounted on this shaft and engaging with the propeller hub 21 is a polished bronze sleeve 24 having rubber gaskets 25<sup>a</sup> at either end. At the left hand end of this sleeve 24 is mounted the hub 25 of a propeller having the buckets or blades 26, the rounded ends of

which fit within correspondingly rounded recesses 27 at the entrance to the venturi 18 so as to impede retrograde movement of the fluid around the tips of the blades.

Bolted to the intermediate casing 17 is an inlet casing 29 having large inlet passageways 30 through which incoming fluid flows over the bronze sleeve 31 abutting the hub 25 of the propeller 26.

This bronze sleeve extends along the shaft 22 and is held in position at its left hand end by the nut 32 and screw 33 which is threaded into the end of the shaft 22. The nut 32 is threaded upon the end of the shaft and also engages with the end of the bronze sleeve 31. This bronze sleeve 31 is mounted in a marine type cutless rubber bearing sleeve 34 held between the end of the inlet casing 29 and the end of the shaft. Around this rubber bearing is a bronze sleeve 35 mounted within the sleeve 36 of a cast iron bearing casing 37 bolted by the bolts 38 on the left hand end of the inlet casing 29. Water passageways 39 provide for the circulation of water to cool and lubricate the bearing. This passageway communicates with the chamber 40 formed within the closed left hand end of the bearing casing 37.

It will be noted that the casing 29 is attached to the casing 17 by the bolts 29<sup>a</sup> and the bolts 3<sup>a</sup> attach the casing 17 to the volute casing 8 and 16. The volute casing is provided with a water passageway 41 controlled by the valve 42 for applying water to the bearing 43 carried within the sleeve 44. A nut 45 retains the bearing 43 and its packing in position by the packing gland 46. This structure is mounted around the hollow sleeve 47 which is an extension of the impeller hub 21 and is hollow for the circulation of air in order to maintain the bearing in cooled condition.

In order to prevent the shaft 22 from moving laterally the bearing 3 has its inner portion set between the shoulders 3<sup>a</sup> and 3<sup>b</sup> screwed on the shaft. The outer portion is carried between the bearing casing ends 4<sup>a</sup> which are, in turn attached by the bolts 5 to the foundation brackets 6 so that there can be no lateral shifting of the shaft.

By tightening the screw 33 the entire sleeve system comprising the sleeves 31, hub 25, sleeve 24 and hub 21 are held tightly against the volute casing 16 and bearing 14. As the casing 16 is mounted on the bracket, it is thus seen that the entire pump is held together on a common base without lost motion or wear and can be ad-

justed by the simple setting of the screw 33 and the nut 32.

It will be understood that I desire to comprehend within my invention such modifications as may be necessary to adapt it to varying conditions and uses.

Having thus fully described my invention, what I claim as new and desire to secure by Letters Patent, is:

10 In a pump, a pump casing having in one side bearings and on its opposite side a cone-shaped wall forming a Venturi inlet, an impeller in the casing having a hollow sleeve mounted in the bearings, a shaft for the impeller projecting

through the inlet, a propeller on the shaft, a sleeve on the shaft between the impeller and propeller, a second sleeve on the shaft to urge the propeller against the first-named sleeve, and a bearing to support the second sleeve for rotation, said propeller comprising propeller blades having rounded ends, said venturi having an entrance opening and a rounded recess of greater diameter than said opening adjacent thereto into which the rounded ends of said propeller blades fit, whereby to prevent retrograde movement of the fluid moved by said propeller blades through said Venturi inlet.

STEPHEN E. SLOCUM.