



INTERNATIONAL APPLICATION PUBLISHED UNDER THE PATENT COOPERATION TREATY (PCT)

<p>(51) International Patent Classification ⁶ : H03H 17/06</p>	<p>A3</p>	<p>(11) International Publication Number: WO 95/17708 (43) International Publication Date: 29 June 1995 (29.06.95)</p>
<p>(21) International Application Number: PCT/FI94/00568 (22) International Filing Date: 16 December 1994 (16.12.94) (30) Priority Data: 935709 17 December 1993 (17.12.93) FI (71)(72) Applicants and Inventors: PAJARRE, Eero [FI/FI]; Kanjoninkatu 11 C 26, FIN-33720 Tampere (FI). EEROLA, Ville [FI/FI]; Tohlopinkatu 15 A 2, FIN-33310 Tampere (FI). SARAMÄKI, Tapio [FI/FI]; Kreetarinkuja 4 A, FIN-33950 Pirkkala (FI). RITONIEMI, Tapani [FI/FI]; Insinöörinkatu 84 B 31, FIN-33720 Tampere (FI). HUSU, Timo [FI/FI]; Kirkkokatu 12 B 23, FIN-80110 Joensuu (FI). INGALSUO, Seppo [FI/FI]; Orivedenkatu 8 C 66, FIN-33720 Tampere (FI). (74) Agent: OY KOLSTER AB; Iso Roobertinkatu 23, P.O. Box 148, FIN-00121 Helsinki (FI).</p>	<p>(81) Designated States: CA, JP, KR, US, European patent (AT, BE, CH, DE, DK, ES, FR, GB, GR, IE, IT, LU, MC, NL, PT, SE). Published <i>With international search report.</i> <i>Before the expiration of the time limit for amending the claims and to be republished in the event of the receipt of amendments.</i> (88) Date of publication of the international search report: 20 July 1995 (20.07.95)</p>	

(54) Title: CALCULATION OF A SCALAR PRODUCT IN A DIRECT-TYPE FIR FILTER

(57) Abstract

The invention relates to a direct-type FIR filter, a method for calculating a scalar product in a FIR filter, and a method for designing a direct-type FIR filter. Successive words of a digital input signal are delayed in a delay line having delays (50A-50D) of the duration of one word, and the scalar product between the variously delayed words derived from the delay line and the corresponding constant coefficients is calculated. In accordance with the invention, calculation of the scalar product comprises: (a) combining the bits of words at the input (X0) and outputs (X1-X4) of the delay line bit by bit in a network of bit-serial subtractor and/or adder elements (51-56) wherein at least one of the bit-serial elements is involved in the multiplication operation of at least two different coefficients; and (b) multiplying (49A-K) the multiplication results from the network by powers of two, and summing together (45-48) the results to yield the scalar product.

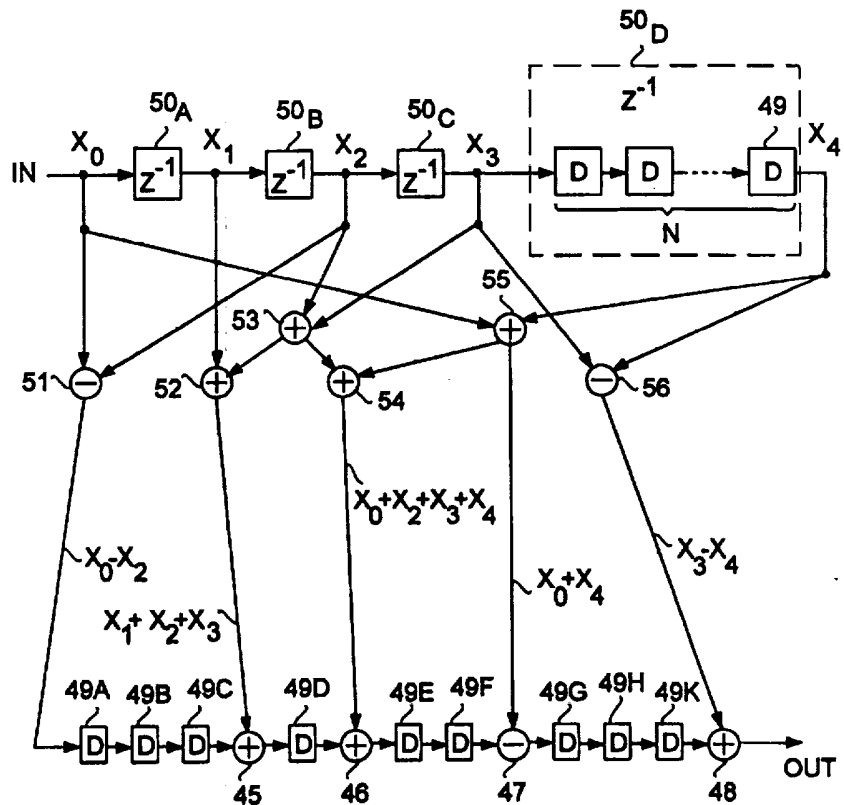

FOR THE PURPOSES OF INFORMATION ONLY

Codes used to identify States party to the PCT on the front pages of pamphlets publishing international applications under the PCT.

AT	Austria	GB	United Kingdom	MR	Mauritania
AU	Australia	GE	Georgia	MW	Malawi
BB	Barbados	GN	Guinea	NE	Niger
BE	Belgium	GR	Greece	NL	Netherlands
BF	Burkina Faso	HU	Hungary	NO	Norway
BG	Bulgaria	IE	Ireland	NZ	New Zealand
BJ	Benin	IT	Italy	PL	Poland
BR	Brazil	JP	Japan	PT	Portugal
BY	Belarus	KE	Kenya	RO	Romania
CA	Canada	KG	Kyrgystan	RU	Russian Federation
CF	Central African Republic	KP	Democratic People's Republic of Korea	SD	Sudan
CG	Congo	KR	Republic of Korea	SE	Sweden
CH	Switzerland	KZ	Kazakhstan	SI	Slovenia
CI	Côte d'Ivoire	LI	Liechtenstein	SK	Slovakia
CM	Cameroon	LU	Luxembourg	SN	Senegal
CN	China	LK	Sri Lanka	TD	Chad
CS	Czechoslovakia	LV	Latvia	TG	Togo
CZ	Czech Republic	MC	Monaco	TJ	Tajikistan
DE	Germany	MD	Republic of Moldova	TT	Trinidad and Tobago
DK	Denmark	MG	Madagascar	UA	Ukraine
ES	Spain	ML	Mali	US	United States of America
FI	Finland	MN	Mongolia	UZ	Uzbekistan
FR	France			VN	Viet Nam
GA	Gabon				

INTERNATIONAL SEARCH REPORT

International application No.
PCT/FI 94/00568

A. CLASSIFICATION OF SUBJECT MATTER		
IPC6: H03H 17/06 According to International Patent Classification (IPC) or to both national classification and IPC		
B. FIELDS SEARCHED		
Minimum documentation searched (classification system followed by classification symbols)		
IPC6: H03H		
Documentation searched other than minimum documentation to the extent that such documents are included in the fields searched		
SE,DK,FI,NO classes as above		
Electronic data base consulted during the international search (name of data base and, where practicable, search terms used)		
C. DOCUMENTS CONSIDERED TO BE RELEVANT		
Category*	Citation of document, with indication, where appropriate, of the relevant passages	Relevant to claim No.
X,P	WO, A1, 9423493 (SARAMÄKI, TAPIO), 13 October 1994 (13.10.94), see whole document --	1-5
A	EP, A1, 0344326 (VICTOR COMPANY OF JAPAN, LTD), 6 December 1989 (06.12.89), figure 3, abstract --	1-5
A	EP, A2, 0384448 (LSI LOGIC CORPORATION), 29 August 1990 (29.08.90), see whole document --	1-5
<input checked="" type="checkbox"/> Further documents are listed in the continuation of Box C. <input checked="" type="checkbox"/> See patent family annex.		
<ul style="list-style-type: none"> * Special categories of cited documents: "A" document defining the general state of the art which is not considered to be of particular relevance "E" earlier document but published on or after the international filing date "L" document which may throw doubts on priority claim(s) or which is cited to establish the publication date of another citation or other special reason (as specified) "O" document referring to an oral disclosure, use, exhibition or other means "P" document published prior to the international filing date but later than the priority date claimed "T" later document published after the international filing date or priority date and not in conflict with the application but cited to understand the principle or theory underlying the invention "X" document of particular relevance: the claimed invention cannot be considered novel or cannot be considered to involve an inventive step when the document is taken alone "Y" document of particular relevance: the claimed invention cannot be considered to involve an inventive step when the document is combined with one or more other such documents, such combination being obvious to a person skilled in the art "&" document member of the same patent family 		
Date of the actual completion of the international search		Date of mailing of the international search report
16 June 1995		20-06-1995
Name and mailing address of the ISA/ Swedish Patent Office Box 5055, S-102 42 STOCKHOLM Facsimile No. +46 8 666 02 86		Authorized officer Per Lindberg Telephone No. +46 8 782 25 00

INTERNATIONAL SEARCH REPORT

International application No.

PCT/FI 94/00568

C (Continuation). DOCUMENTS CONSIDERED TO BE RELEVANT		
Category*	Citation of document, with indication, where appropriate, of the relevant passages	Relevant to claim No.
A	EP, A2, 0281101 (NEC CORPORATION), 7 Sept 1988 (07.09.88), see whole document -- -----	1-5

INTERNATIONAL SEARCH REPORT

Information on patent family members

03/05/95

International application No.

PCT/FI 94/00568

Patent document cited in search report	Publication date	Patent family member(s)	Publication date
WO-A1- 9423493	13/10/94	NONE	
EP-A1- 0344326	06/12/89	DE-D, T- 3851053 JP-A- 1146418 US-A- 5081604 WO-A- 8905544	01/12/94 08/06/89 14/01/92 15/06/89
EP-A2- 0384448	29/08/90	JP-A- 2222317	05/09/90
EP-A2- 0281101	07/09/88	AU-B- 606392 AU-A- 1253988 DE-D, T- 3886070 JP-A- 63214024 US-A- 5042026 JP-A- 1101719 JP-B- 6093598 JP-A- 1101720	07/02/91 01/09/88 14/04/94 06/09/88 20/08/91 19/04/89 16/11/94 19/04/89