

July 7, 1970

S. SANTI

3,519,087

IMPACT TOOL

Filed Dec. 18, 1968

FIG. 1.

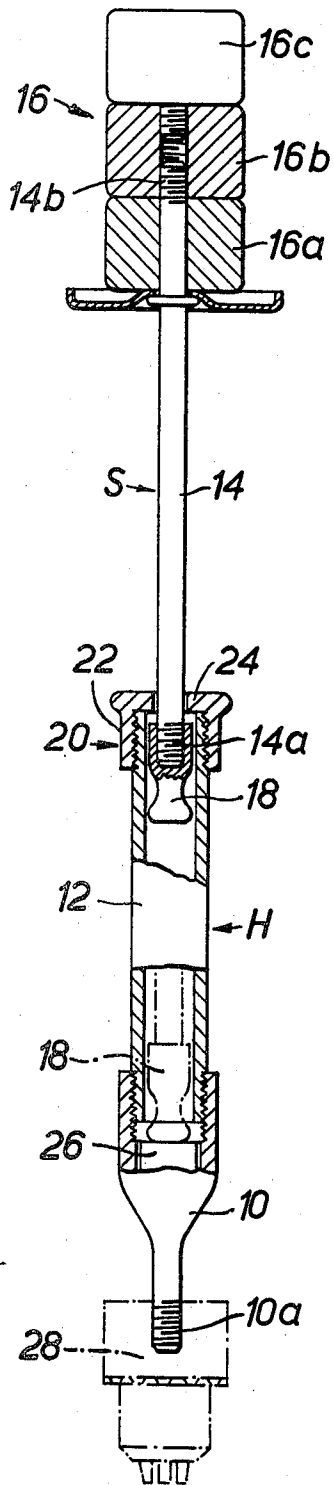
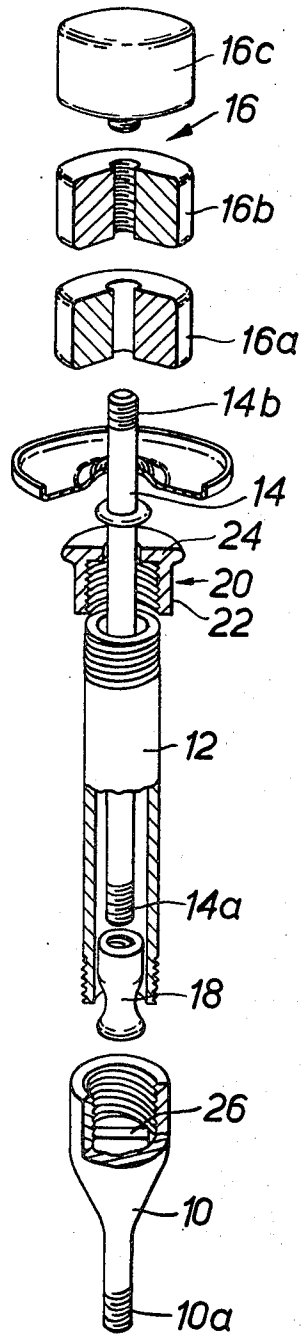

FIG. 2.



INVENTOR

BY SILVIO SANTI

Leon Anthony
ATTORNEY

3,519,087

IMPACT TOOL

Silvio Santi, 262 Margueretta St.,
Toronto, Ontario, Canada

Filed Dec. 18, 1968, Ser. No. 784,607

Int. Cl. B25d 17/00

U.S. Cl. 173—91

4 Claims

ABSTRACT OF THE DISCLOSURE

An impact tool comprised of a tubular handle having a tool bit secured thereto and a striker slidably movable within the handle to impinge either one of two stops at each end of the handle. The striker is connected by an elongated shaft to a heavy grip for applying high momentum impact strokes to either stop and hence to the tool bit.

This invention relates to an impact tool of the type wherein impetus is delivered to a tool head thereof by percussive engagement of a weighted movable part of the tool directly or indirectly with the tool head.

Known impact tools have included an elongated shaft having a handle at one end and a tool head at the other, both handle and head being provided with stops permitting impetus to be imparted to the tool head in each of two opposite directions by a weighted sleeve slidably movable on the shaft for impinging upon said stops. The weighted sleeve of such a tool is manually gripped and moved along the shaft by one hand of the operator whilst the operator's other hand holds the tool handle.

It is a broad object of the present invention to provide an impact tool of simple, yet sturdy, construction which is reliable in use and which is easily useable in situations of difficult access. For example, the instant impact tool may be particularly advantageously utilized in the removal of dents from automobile body panels wherein it is frequently necessary to engage a tool head thereof with the body panel in a re-entrant section thereof.

It is a further object of the invention to provide such an impact tool capable of delivering impact strokes to its tool head in either a "push" or "pull" direction and it is another object of the invention to provide such a tool wherein the tool head and/or a tool bit thereof is readily removable and replaceable with another type of head or bit.

It is a yet further object to provide such an impact tool having a weighted grip for applying a relatively large momentum to a striker which, in turn, applies impetus to the tool head upon direct or indirect impact therewith and it is an associated object to provide such an impact tool wherein the weight of the grip is adjustable.

In accordance with the invention, there is provided an impact tool having a handle and tool head connected thereto, a shaft movable relative to the handle having a striker at one end and a grip at the other, the shaft, grip and striker being co-movable towards and away from the tool head for delivering an impact stroke thereto in each of two directions. The said handle is preferably of tubular form with a stop provided adjacent each end thereof, said striker being captive and movable between said stops for selective impingement therewith for delivering impetus to said tool head in a desired "push" or "pull" direction.

Other objects of the invention, more or less broad than the foregoing, will become apparent from the herein-after following description of the parts, principles and elements of the invention given herein solely by way of example with reference to the accompanying drawings wherein:

FIG. 1 is a side cross-sectional view of the instant tool and

FIG. 2 is a partly sectional exploded perspective view of the tool.

As illustrated herein, the impact tool of the invention is comprised essentially of a handle assembly H providing a bearing for a striker assembly S. The handle assembly H includes a tool head 10 engaged with a handle 12 whilst the striker assembly S includes an elongated shaft 14 having a grip 16 and a striker 18 connected to opposite ends of said shaft 14; the shaft 14, grip 16 and striker 18 all being co-movable together.

In accordance with the inventive concept, the striker assembly S is movable in two opposite directions respectively relative to the handle assembly H towards and away from the tool head 10 for delivering an impact stroke in each of said directions, each said impact stroke imparting an impetus to the tool head 10. Such an arrangement of parts enables the impetus to be imparted to the tool head 10 in either direction corresponding to the direction of movement of the striker assembly S. Thus, referring to the drawings, when the striker assembly S is moved downwardly, impetus will be imparted to the tool head 10 in a downward direction thereby giving rise to a "push" stroke to the tool head 10 whilst, conversely, upward movement of the striker assembly S will give an impetus to the tool head 10 in an upward direction resulting in a "pull" stroke of the tool head 10.

Referring now to the drawing in more detail, it will be seen that, in the present embodiment, the handle 12 itself is comprised of an elongated tubular member providing accommodation for an elongated shaft 14 of circular cross-section reciprocally slidable within the handle 12. That end 14a of the shaft 14 which is located within the handle 12 carries the striker 18 thereon whilst the other end 14b of the shaft 14 carries the grip 16; the striker 18 having a circular transverse cross-section of external diameter slightly less than the internal diameter of the handle 12 thereby permitting a sliding fit of the striker 18 within the handle 12 and hence providing a bearing within the handle 12 for the shaft 14. That end of the handle 12 adjacent the grip 16 is provided with a bushing 20 providing further bearing for the shaft 14 and having an internal diameter of somewhat less than the external diameter of the striker 18 so that it is captively retained within the handle 12 against movement thereof in an upward direction as shown in the drawings.

The other end of the handle 12 carries the tool head 10 detachably secured thereon by a suitable connection such as the screw-threaded connection illustrated in the drawings. All of the parts of the impact tool may be in detachable engagement one with another such as by screw-threaded connection; thus, as illustrated herein, the striker 18 is screw-threadedly engaged upon the shaft 14 at one end thereof whilst the grip 16 is screw-threadedly engageable thereon at the other end and the bushing 20 is screw-threadedly engaged upon that end of the handle 12 remote from the tool head 10. The grip 16 itself is of a substantial weight so as to be capable of imparting a relatively large momentum to the striker assembly S upon movement thereof relative to the tool head 10 for applying a relatively high impetus to the tool head 10 as desired. The aforesaid weighted grip 16 is comprised of a plurality of weights 16a, 16b, 16c all detachably secured one to another such as by the screw-threaded connections illustrated whereby the effective momentum of the striker assembly S may be adjusted as desired.

As mentioned hereinbefore, the bushing 20 has an internal diameter so dimensioned as to retain the striker 18 within the handle 12 upon movement of the striker 18 towards the bushing 20. As will be seen from the drawings, the bushing 20 is comprised of a relatively large diameter body 22 screw-threadedly engaged upon the ex-

terior of the handle and an annular centrally-apertured flange 24 forming a part of the bearing for the shaft 14. By virtue of the reduced internal diameter of flange 24, there is provided a stop (referred to herein by the same numeral 24) for arresting movement of the striker assembly S upon movement thereof in a direction away from the tool head 10. Thus, when such movement is arrested by impingement of the striker 18 upon the bushing flange 24, an impetus is imparted to the tool head 10 resulting in a "pull" stroke thereto.

In the present embodiment, impetus is imparted to the tool head 10 in the opposite direction, i.e. downwardly as shown in the drawings, resulting in a "push" stroke to the tool head 10 by the provision of a second stop 26 for arresting movement of the striker 18 in this said direction. Such stop 26 is engaged with handle 12 in spaced and relation with the stop 24 provided by the aforesaid bushing flange thereby retaining the striker 18 captive within the handle 12 between the two stops 24-26 and, in the present embodiment, said second stop 26 is, in fact, provided on the detachable tool head 10 itself. Therefore, downward movement of the striker assembly S will cause the striker 18 to impinge said second stop 26 (at the position shown in dotted line in FIG. 1) with consequent arrest of movement of the assembly S and the imparting of an impetus to the tool head 10 in the same direction, i.e. downwardly as shown in the drawings.

It will be appreciated that, since the tool head 10 is detachable by the simple expedient of unscrewing it relative to the handle, any desired shape or form of tool head 10 may be fitted upon the tool adapted for either a "push" or "pull" strike or both dependent upon the type of work required to be carried out by the tool. The tool head 10 may carry a tool bit proper integral therewith or, as illustrated herein, it may be provided with a connector such as threaded stud 10a, for detachably mounting a tool bit thereon, in which case interchange of tool bits may be accomplished as desired without detaching the tool head 10 from the handle 12. For example, as shown in FIG. 1, a chuck 28 may be mounted upon tool head 10 for carrying a tool bit thereon. Also, since the shaft 14 is itself readily detachable from the grip 16 and striker 18, a shaft 14 of any desired length may be installed in the tool with a striker 18 at one end captive within the handle 12 between the two stops 24-26 and a weighted grip 16 at the other end whereby the tool may be used in locations which are of difficult access. In particular, it is envisaged that the instant tool be used for the knocking out of dents in automobile body panels, which work is normally required to be carried out on the inner surface of such panels and which often includes reentrant angles normally difficult of access.

It will be appreciated that the instant tool may be grasped by, for example, the left hand of the operator holding the handle 12 with the tool head in engagement with the part of the work to be hammered, whilst the right hand of the operator grasps the grip 16. Thus if an extremely long shaft 14 is utilized, the grip 16 may be some considerable distance from the tool head 10 and handle 12 whereby the operator may freely move his right hand to impart hammering strokes in either a "push" or "pull" direction to the tool head 10 thereby imparting the required hammer blows to the work.

It will be appreciated that the hereinbefore described

embodiments of the invention have been selected solely for the expository purposes hereof and should not be construed in a limiting sense; various modifications being readily suggestible to those skilled in the art and the true scope of the invention being restricted only by the claims hereinafter set forth.

What I claim is:

1. A heavy duty impact tool including:
 - an elongated tubular handle;
 - a tool head at one end of said handle;
 - a stop adjacent said tool head occluding the interior of said handle and,
 - a bushing detachably secured to the other end of said handle;
 - an elongated shaft;
 - a striker detachably secured to one end of said shaft, and
 - a weighted grip detachably secured to the other end of said shaft;
- said striker being captive within said handle and co-movable, together with said shaft and said weighted grip, towards said stop for procuring impingement thereon by said striker for imparting impetus to said tool head in one direction,
- the interior of said handle providing a bearing for said striker and the bushing providing a bearing for said shaft,
- said bushing being removable from said handle and said striker being removable from said shaft permitting removal of said shaft through that end of the handle remote from the tool head and said grip also being removable from said shaft to permit interchangeability of said shaft with another shaft of different length assemblable with said grip, striker, bushing and handle.
2. An impact tool as claimed in claim 1 wherein: said bushing constitutes a stop impingeable by said striker when it is moved away from said tool head for imparting impetus to said tool head in the opposite direction to said aforesaid.
3. An impact tool as claimed in claim 1 wherein: said tool head and said stop are detachably secured to said handle and removable therefrom, together with said bushing, permitting interchangeability of said handle with another handle of different length assemblable with said tool head, stop and bushing.
4. An impact tool as claimed in claim 3 wherein: said stop and said tool head are integral with one another.

References Cited

UNITED STATES PATENTS

54,852	5/1866	Burnham	30-164.6
280,995	7/1883	Armstrong	30-277 X
503,298	8/1893	Teufel	30-277 X
3,136,040	6/1964	Bauer et al.	173-91 X
3,245,482	4/1966	Williams et al.	173-126

FOREIGN PATENTS

657,594	9/1951	Great Britain.
---------	--------	----------------

ERNEST R. PURSER, Primary Examiner

U.S. Cl. X.R.

29-254, 275; 81-52.35; 173-126