

EUROPEAN PATENT APPLICATION

Application number: **88106330.9**

Int. Cl.4: **H01H 73/18 , H01H 9/34**

Date of filing: **20.04.88**

Priority: **21.04.87 JP 99027/87**
21.04.87 JP 99026/87
21.04.87 JP 99028/87
21.04.87 JP 99029/87

Applicant: **mitsubishi denki kabushiki**
KAISHA
2-3, Marunouchi 2-chome Chiyoda-ku
Tokyo 100(JP)

Date of publication of application:
26.10.88 Bulletin 88/43

Inventor: **Hisatsune, FumiYuki c/o Fukuyama**
Seisakusho
Mitsubishi Denki Kabushiki Kaisha
1-8, Midorimachi Fukuyama-shi, 720(JP)
 Inventor: **Fujii, Hiroshi c/o Fukuyama**
Seisakusho
Mitsubishi Denki Kabushiki Kaisha
1-8, Midorimachi Fukuyama-shi, 720(JP)

Designated Contracting States:
CH DE FR GB IT LI

Representative: **Kuhnen, Wacker & Partner**
Schneggstrasse 3-5 Postfach 1553
D-8050 Freising(DE)

54 Circuit Breaker.

57 A circuit breaker having arc-extinguish grids on which arc-proof insulation films are applied for preventing undesirable arc staying and for preventing undesirable arc short-circuit; by providing the insulation films superior breaking efficiency can be obtained.

FIG. 2 B

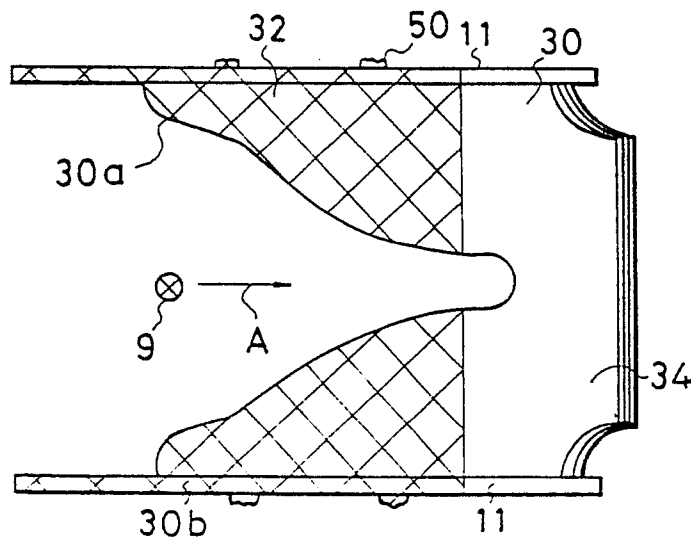

EP 0 288 040 A2

Circuit breaker

FIELD OF THE INVENTION AND RELATED ART STATEMENT

1. FIELD OF THE INVENTION

The present invention relates to a circuit breaker, particularly to an improvement of arc extinguish structure.

2. DESCRIPTION OF THE RELATED ART

FIG.1A shows structure nearby a contact and arc extinguish grids 10 of a circuit breaker of the prior art. A fixed contact 4 and an arc runner 5 are fixed on a fixed arm 3. The fixed arm 3 is fixed by a bolt 12 and a folded tip part 31 of the fixed arm 3 is also fixed by a bolt 12. A movable contact 2 is provided on a movable arm 1. In a closing state, the movable contact 2 and fixed contact 4 are contacted.

When an over-current flows in a circuit, the movable contact 2 is disconnected from the fixed contact 4 by releasing device (not shown). At this time, an arc 9a occurs between the movable contact 2 and the fixed contact 4. When the movable arm 1 is moved in position x, the arc is moved in a position 9b. FIG.1B is a plan view for showing a relation between the arc 9 and the arc extinguish grid 10. The arc extinguish grid 10 is made of magnetic material and has notch 10a for introducing the arc. Because the notch 10a is formed, lines of magnetic force are deflected as shown in FIG.1B. Therefore, the arc 9 is moved in a direction shown by an arrow A. Referring not to FIG.1A, the arc is moved from 9b to 9f through 9c, 9d and 9e. Moved arc 9 is stretched, divided and extinguished as described above.

The conventional circuit breaker as above suffers the following problems.

When the arc is not smoothly moved and thus the arc moves to a side end of notch 10a, i.e., to a position 99 as shown in FIG.1B, the arc 99 stays in this position by emission of thermoelectron from the arc extinguish grid 10. Especially, such staying of the arc is occurred in part S in FIG.1A. Therefore, the arc runs slowly, the extinguishment is delayed and thus breaking efficiency is deteriorated.

When a high voltage is broken or a large current shortcircuit arises, there are some cases that arc runs over from the rear end of grids 10 and makes arc shortcircuiting 9g as shown in FIG.1A.

OBJECT AND SUMMARY OF THE INVENTION

It is an object of the present invention to provide a circuit breaker having superior breaking efficiency.

A circuit breaker in accordance with the present invention comprises:

- a fixed arm,
- a fixed contact provided on the fixed arm,
- a movable arm which is provided movable by a releasing means,
- a movable contact which provided on the movable arm in a manner to be disconnected from the fixed contact by the releasing means,
- an arc-runner end of which is fixed to the fixed arm, and

arc extinguished grids of magnetic material which are positioned in an upper space of the arc-runner and have their surfaces nearby perpendicular to an arc, and have insulation films thereon formed on the surface of arc-introducing parts thereof.

A circuit breaker in accordance with the present invention comprises:

- a fixed arm,
- a fixed contact provided on the fixed arm,
- a movable arm which is provided movable by a releasing means,
- a movable contact which is disconnected from the fixed contact by the releasing means,
- an arc-runner end of which is fixed to the fixed arm, and

arc extinguish grids of magnetic material which are positioned upper space of the arc-runner and which surfaces are nearly perpendicular to an arc wherein insulation films are formed at rear end thereof.

While the novel features of the invention are set forth particularly in the appended claims, the invention, both as to organization and content, will be better understood and appreciated, along with other objects and features thereof, from the following detailed description taken in conjunction with the drawings.

BRIEF DESCRIPTION OF DRAWINGS

FIG.1A is the sectional view of the circuit breaker of prior art.

FIG.1B is the plan view of the arc extinguish grid of the circuit breaker of FIG.1A.

FIG.2A is a side view of a circuit breaker of an embodiment of present invention.

FIG.2B is a plan view of the embodiment of FIG.2A.

FIG.2C is a sectional view of the embodiment of FIG.2A.

FIG.3A is a sectional view of a circuit breaker of another embodiment of present invention.

FIG.3B is a plan view of the embodiment of FIG.3A.

FIG.4A is a side view of a circuit breaker of another embodiment of present invention.

FIG.4B is a plan view of the same.

FIG.5A is a side view of a circuit breaker of another embodiment of the present invention.

FIG.5B is a plan view of the same.

DESCRIPTION OF THE PREFERRED EMBODIMENTS

FIG.2A shows a preferred embodiment of a circuit breaker embodying the present invention. A fixed contact 4 and an arc runner 5 are fixed on a fixed arm 3. The fixed arm 3 is fixed by a bolt 12, and a folded tip part 31 of the fixed arm 3 is also fixed by a bolt 12. A movable contact 2 is provided on a movable arm 1. Arc extinguish grids 30 are fixed to side plates 11 by caulking protrusions 50 provided at side part of the extinguish grids 30 after inserting the protrusions 50 into holes of the side plates 11. The arc extinguish grid 30 is made of magnetic material and has its surface nearly perpendicular to an arc. An insulation film 32 covers a front part of the extinguish grid 30. Therefore, the extinguish grid 30 has insulation part 32 and metallic part 34. Arc-proof insulating paint, such as arc-proof epoxy coating paint (Limitrack: trademark of Ryoden Kasei), or liquid ceramic, is suitable for the insulation film 32. In this embodiment, the insulation film 32 is formed by dipping the arc extinguish grids 30 and the side plates 11 into a solution of the arc-proof insulating paint. The insulation film 32 covers arc introducing part 30b of arc extinguish grid 30. In addition, when the caulked parts 50 are also covered with the arc-proof insulating paint, the caulked parts 50 are prevented from rusting.

There is often a trouble that powder is generated from the edge of side plate 11 by vibration

of the circuit breaker and the powder causes incomplete connection of contact. Such trouble is prevented by prevention of generation of the powder by the arc-proof insulating paint.

Referring now to FIG.2A, operation of the circuit breaker is described hereafter. In a closing state, the movable contact 2 and fixed contact 4 are made contact. When an over-current flows in a circuit, the movable contact 2 is disconnected from the fixed contact 4 by known releasing device (not shown). At this time, an arc 9a is produced between the movable contact 2 and the fixed contact 4.

The arc extinguish grid 10 is made of magnetic material such as iron and has notch 10a for introducing the arc. Because the notch 10a is formed, lines of magnetic force are deflected (see FIG.1B). Therefore, the arc 9 is moved in the direction shown by an arrow A.

Even when the arc touching the insulation part 32 of extinguish grid 30, thermoelectrons are not emitted from the arc extinguish grid 30 since the arc-proof insulation film 32 is formed. Therefore, the arc does not stay, but is smoothly move in the metallic part 34 of arc extinguish grid 30. When the arc 9 touches the metallic part 34 of the arc extinguish grid 30, the arc 9 is smoothly quenched.

In other embodiment, after dripping the arc extinguish grids 30 into a solvent arc-proof insulating paint to such a predetermined portion that the side plate 11 only is dipped wholly in the arc-proof insulating paint. In this embodiment, generation of the powder from the edge of side plate 11 due to vibration of the circuit breaker is prevented.

FIG.3A is a sectional view of a circuit breaker of another embodiment, and FIG.3B is a plan view thereof. In this embodiment, the insulation films 32 are formed in such a manner that the arc extinguish grid is covered by the insulation film 32 wider at the part near the arc-runner 5, but narrower at the portion far from the arc-runner 5.

Since the arc extinguish grids 30 which are nearer to the arc runner 5 has higher liability of sticking by the arc than those farther therefrom (as has been described with reference to FIG.1A), the above-mentioned configuration of making the insulation film 32 wider near the arc-runners 5 than other portion results in better prevention of the arc-staying at arc extinguish grids 30.

FIG.4A is a sectional view of a circuit breaker of still another embodiment which is suitable for high voltage and large current, and FIG.4B is a plan view thereof. In this embodiment, the insulation films 32 are formed at rear ends of the arc extinguish grids 30.

In a closing state, the movable contact 2 is touching with the fixed contact 4. When an over-current flows in a circuit, the movable contact 2 is

disconnected from the fixed contact 4 by a known releasing device (not shown). At this time, an arc 9 arises between the movable contact 2 and the fixed contact 4.

The arc extinguish grid 10 is made of magnetic material and has notch 10a for introducing the arc. Because the notch 10a is formed, lines of magnetic force are deflected (see FIG.1B). Therefore, the arc 9 is moved in the direction shown by an arrow A. Finally, the arc 9 is moved in the rear ends of the arc extinguish grids 30. Because the rear ends of the grids 30 are covered by the insulation film 32, shortcircuiting by an arc at the rear part as 9g in FIG.1A is prevented, and thus superior and stable breaker efficiency is obtainable.

FIG.5A and FIG.5B show still other modified embodiment, wherein the insulation film 32 covers limited part behind the notch 30a of the arc extinguish grid 30. In this embodiment, since considerable metallic part 34 is exposed, arc contact time to the metallic part 34 of the arc extinguish grid 30 is longer than that in the embodiment of FIG.4A. Therefore, the cooling and quenching of arc is efficient.

Although the invention has been described in its preferred form with a certain degree of particularity, it is understood that the present disclosure of the preferred form has been changed in the details of construction and the combination and arrangement of parts may be resorted to without departing from the spirit and the scope of the invention as hereinafter claimed.

Claims

1. A circuit breaker comprising:
 a fixed arm,
 a fixed contact provided on said fixed arm,
 a movable arm which is provided movable by a releasing means,
 a movable contact which provided on said movable arm in a manner to be disconnected from said fixed contact by said releasing means,
 an arc-runner end of which is fixed to said fixed arm, and
 arc extinguish grids of magnetic material which are positioned in an upper space of said arc-runner and have their surfaces nearly perpendicular to an arc, and have insulation films thereon formed on the surface of arc-introducing parts thereof.

2. A circuit breaker in accordance with Claim 1, wherein
 said insulation films are formed wider on arc extinguish grid near said arc-runner than on other arc extinguish grid.

3. A circuit breaker in accordance with Claim 1 or 2, wherein.

said arc extinguish grid is fixed to a pair of side plates having plural holes by caulking protrusions provided at side parts of said extinguish grids after inserting said protrusions into said holes.

4. A circuit breaker in accordance with Claim 3, wherein

said insulation films are layers of dip-coat layer made on the surface said arc extinguish grids and said side plates.

5. A circuit breaker comprising:

a fixed arm,
a fixed contact provided on said fixed arm,
a movable arm which is provided movably by a releasing means,

a movable contact which is disconnected from said fixed contact by said releasing means,

an arc-runner end of which is fixed to said fixed arm, and

arc extinguish grids of magnetic material which are positioned upper space of said arc-runner and which surfaces are nearly perpendicular to an arc wherein insulation films are formed at rear end thereof.

6. A circuit breaker in accordance with Claim 5, wherein

each of said arc extinguish grid has a notch at front end thereof and said insulation film is provided behind said notch.

7. A circuit breaker in accordance with Claim 5 or 6, wherein

said arc extinguish grid is fixed to a pair of side plates having plural holes by caulking protrusions provided at side part of said extinguish grid after inserting said protrusions into said holes.

8. A circuit breaker in accordance with Claim 7, wherein

said insulation films are layers of dip-coat layer made on the surface said arc extinguish grids and said side plates.

FIG. 1A (Prior Art)

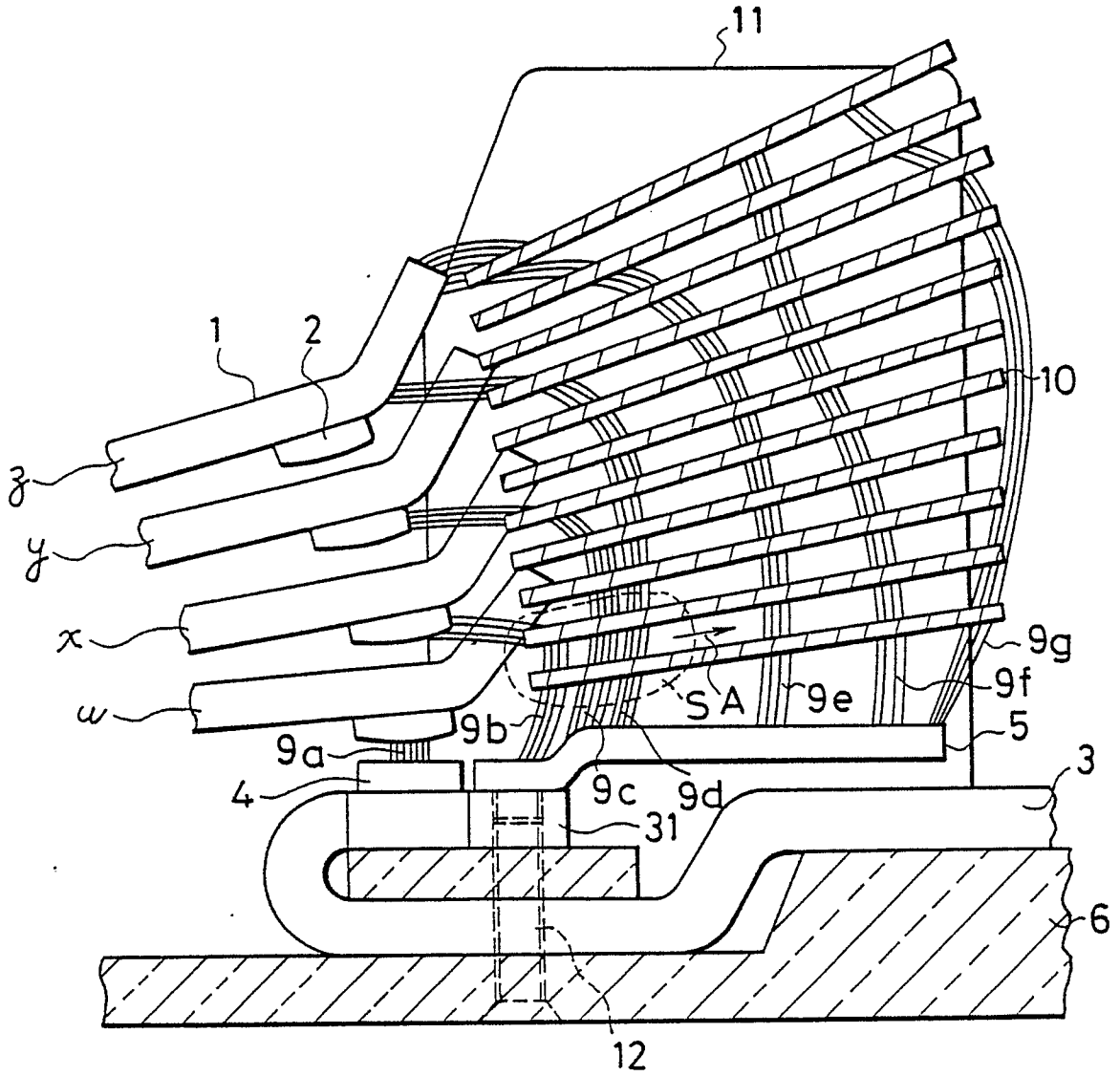
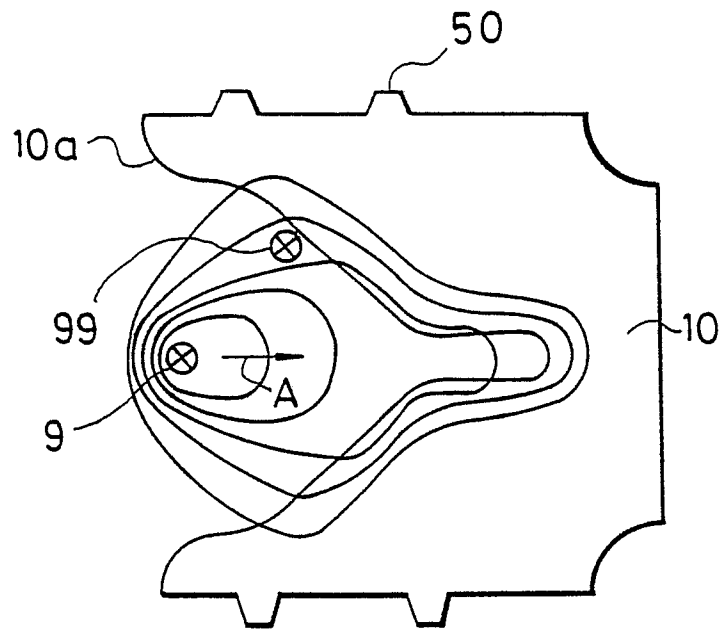

FIG. 1B (Prior Art)



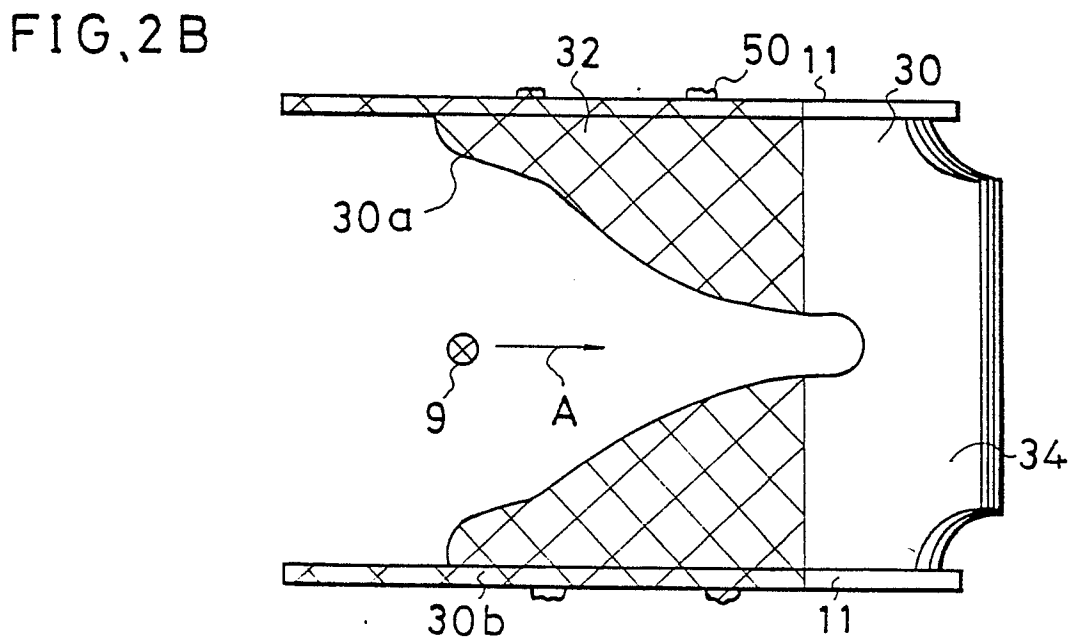
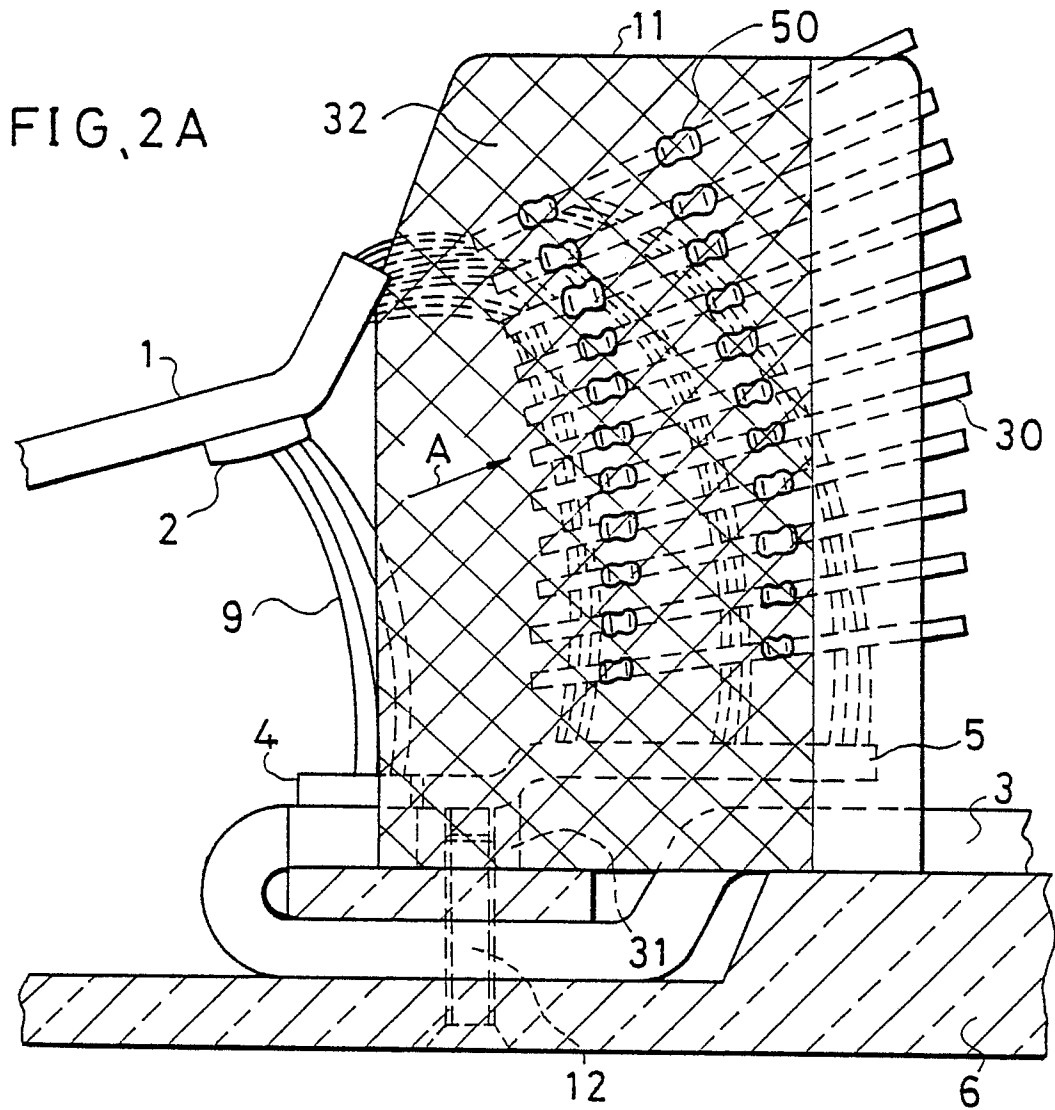

FIG. 2C

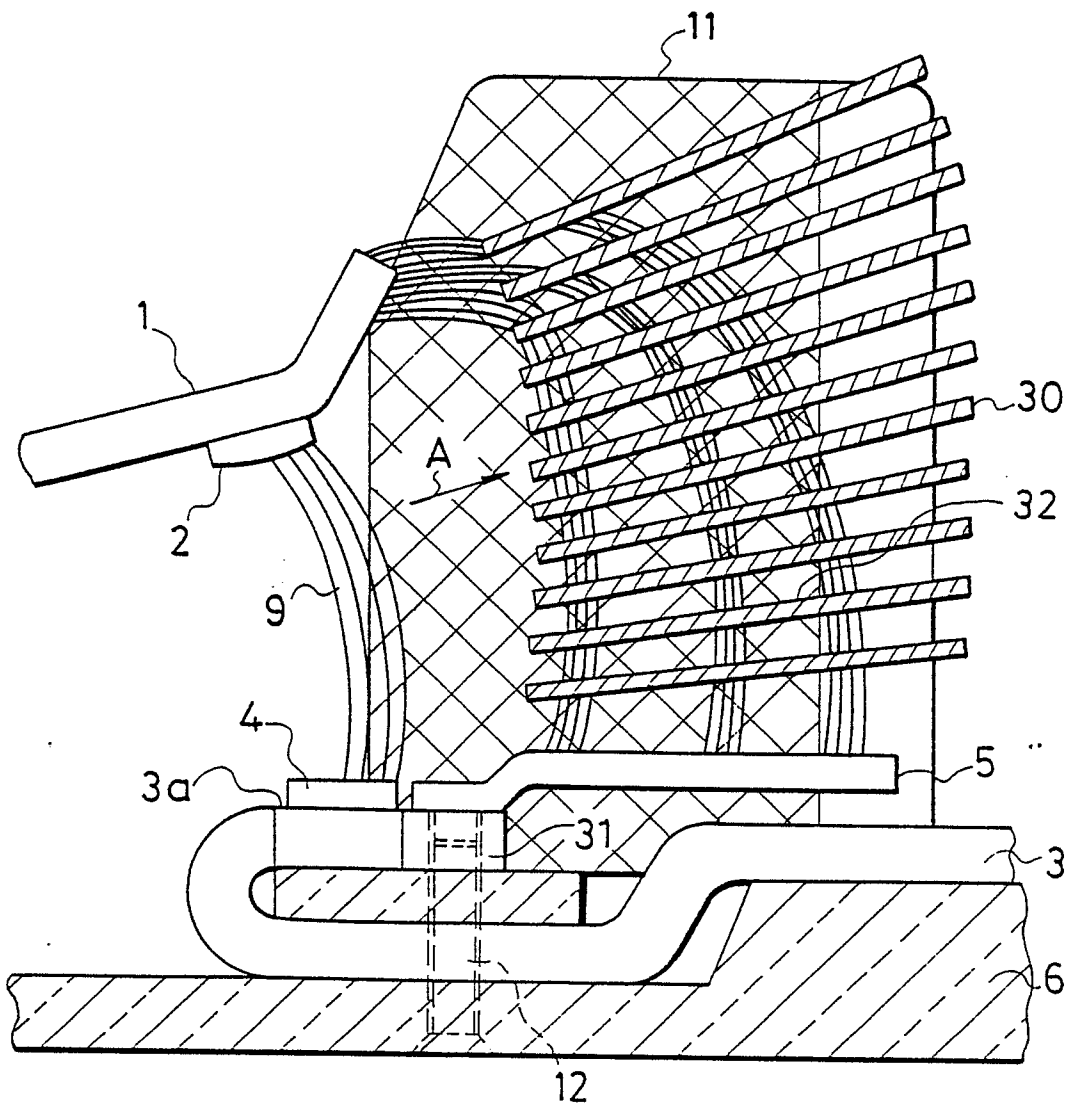

FIG. 3A

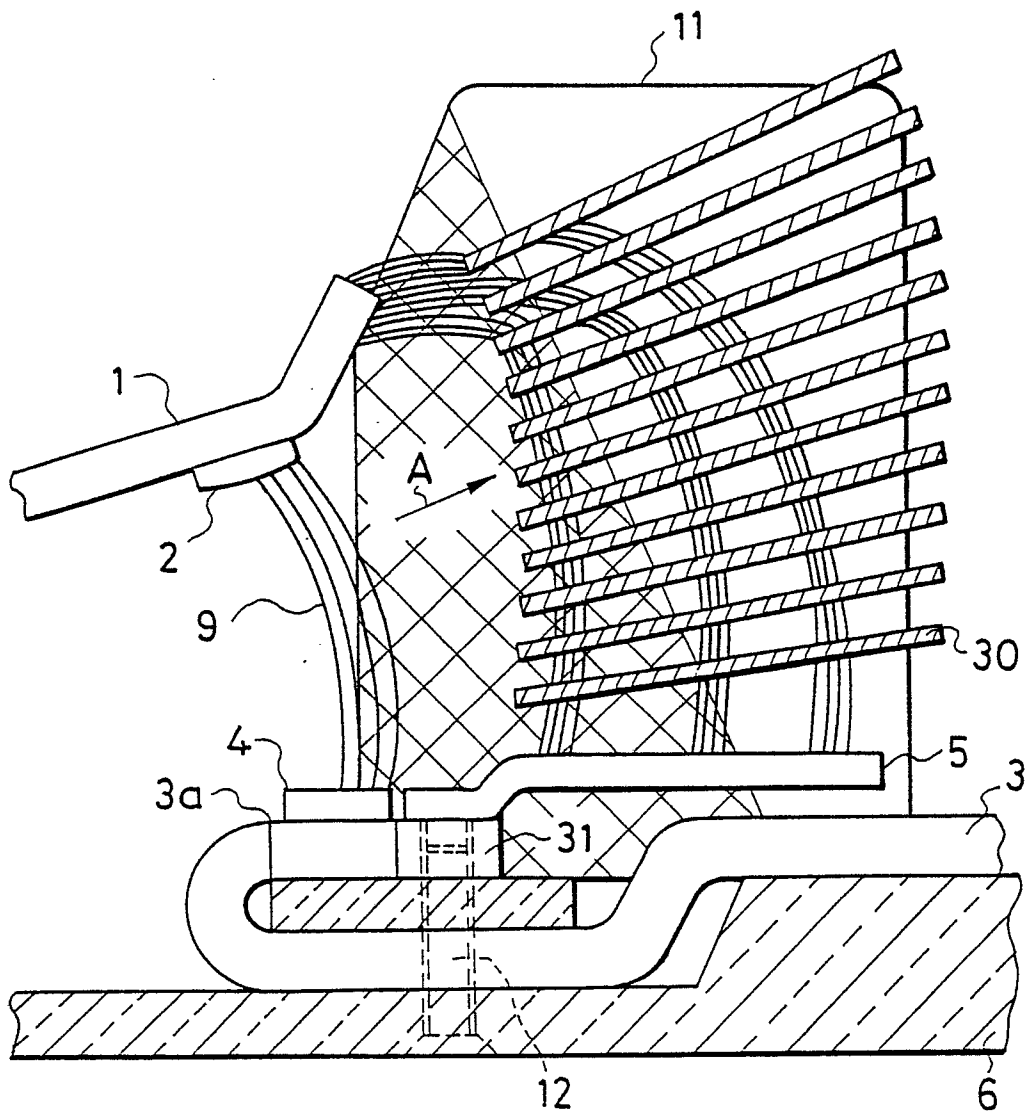

FIG. 3B

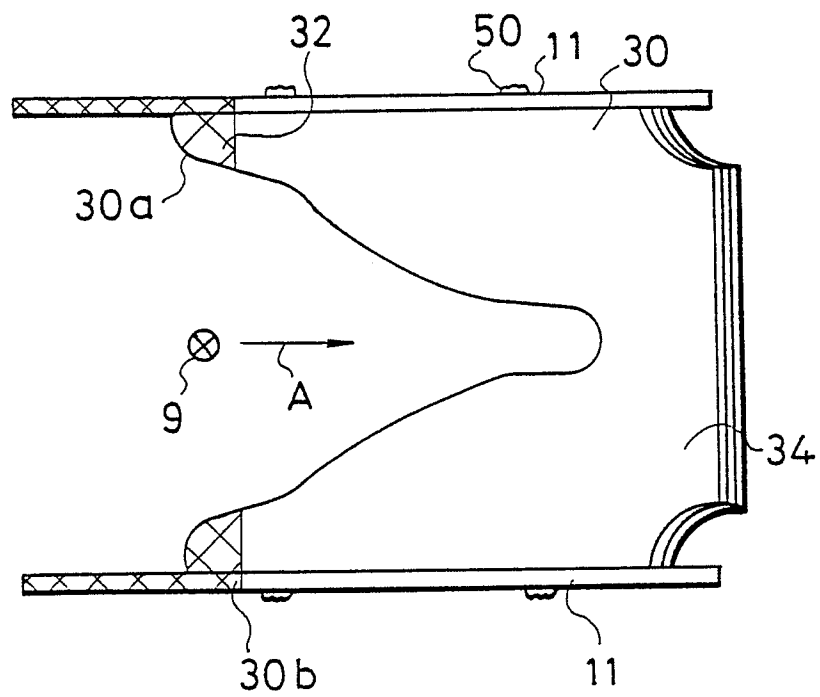

FIG. 4A

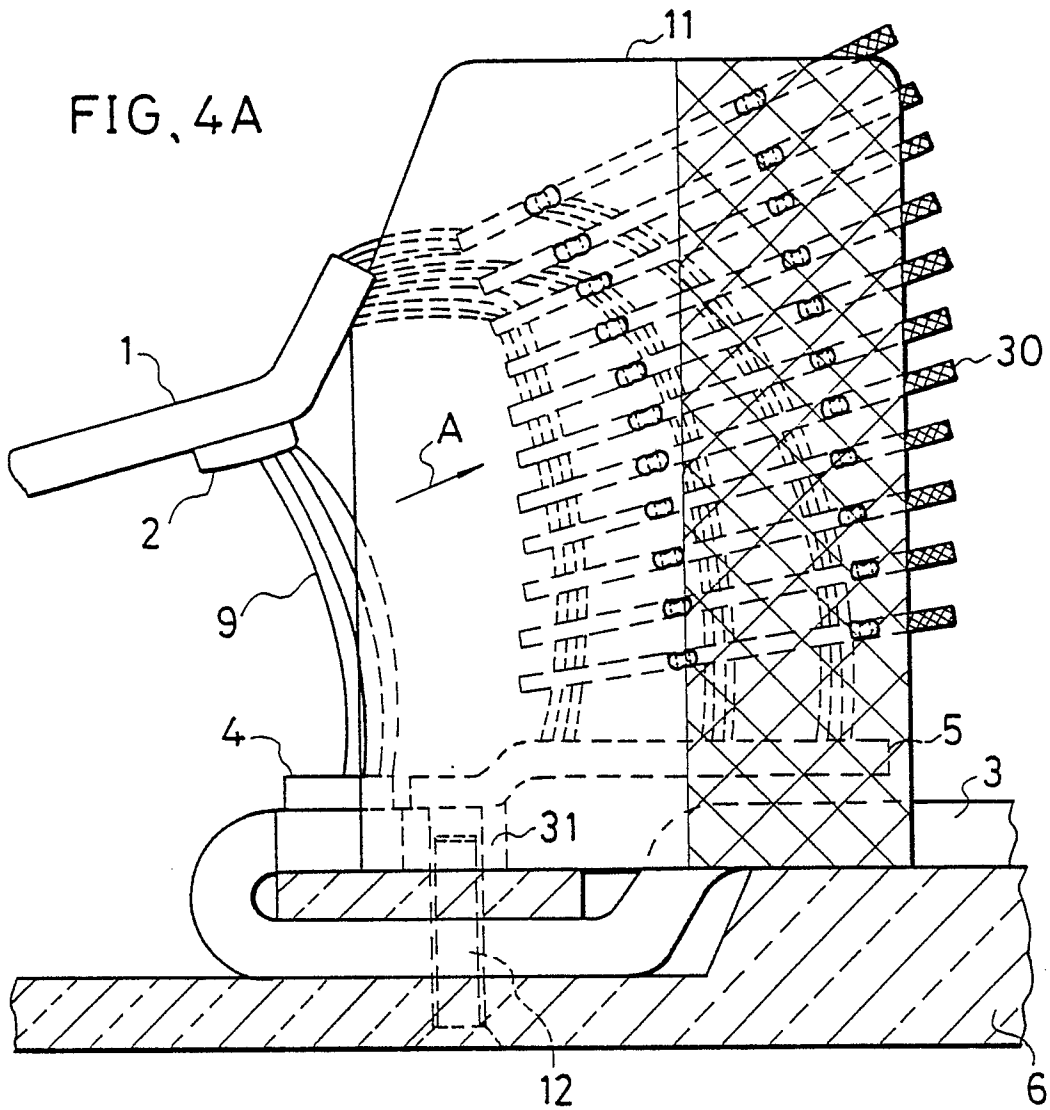

FIG. 4B

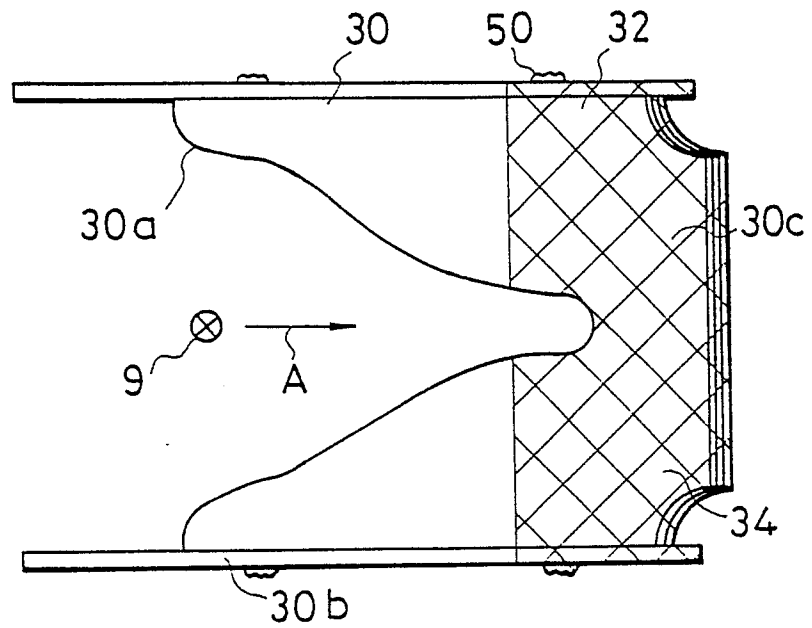

FIG. 5A

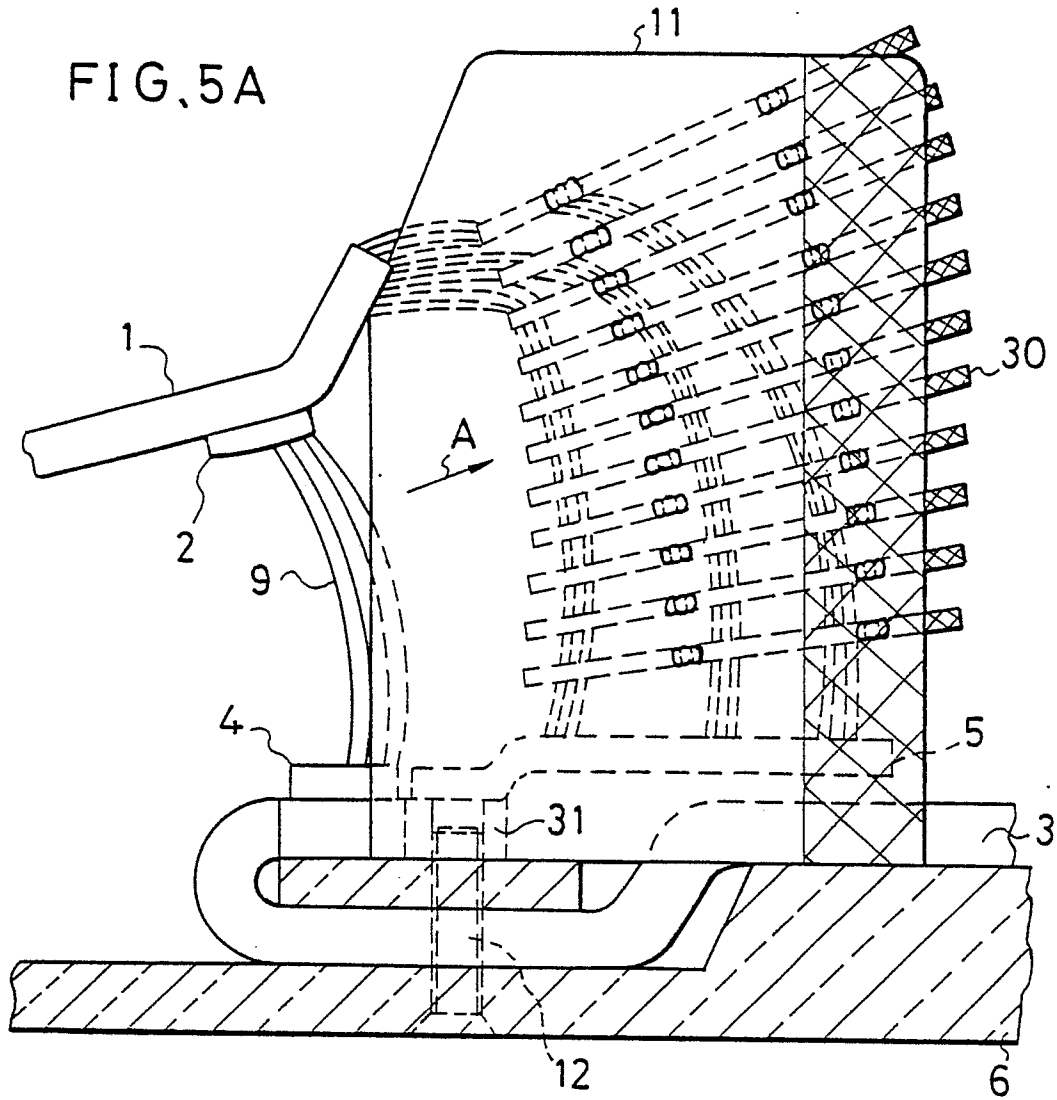

FIG. 5B

