

April 10, 1951

C. I. LONGENECKER

2,548,733

APPARATUS FOR PUMPING CONCRETE

Filed Aug. 29, 1947

3 Sheets-Sheet 1

Fig. 1.

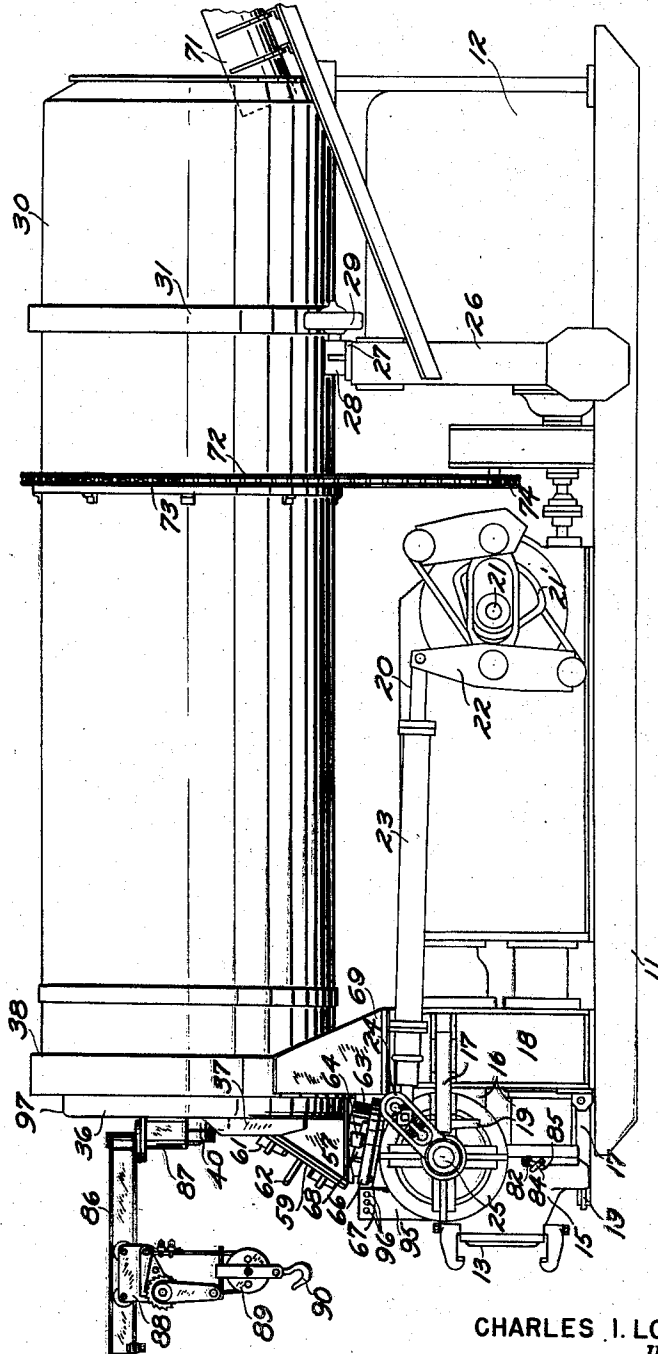

CHARLES I. LONGENECKER
INVENTOR.

BY *George A. Evans*
ATTORNEY

April 10, 1951

C. I. LONGENECKER

2,548,733

APPARATUS FOR PUMPING CONCRETE

Filed Aug. 29, 1947

3 Sheets-Sheet 2

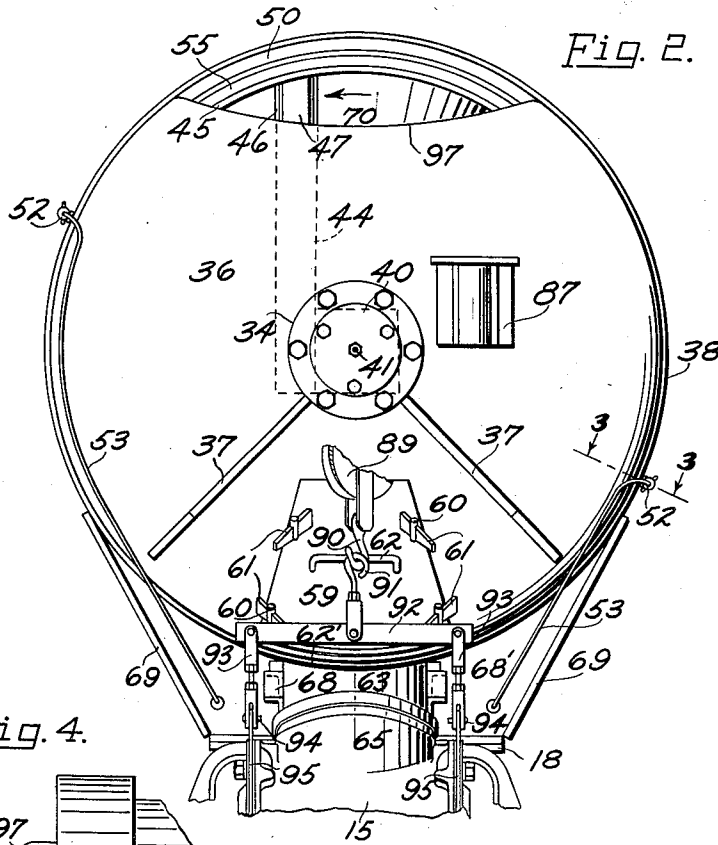

Fig. 2.

Fig. 4.

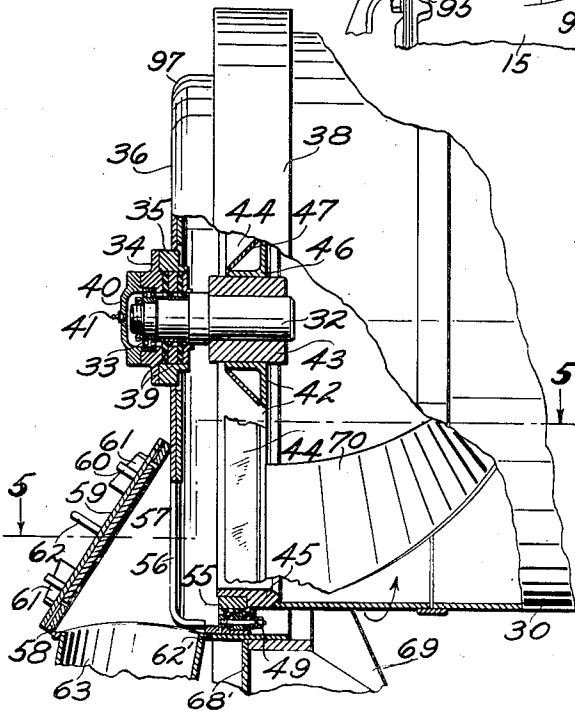
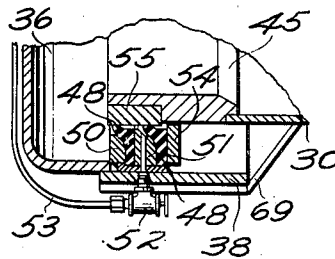

Fig. 3.



CHARLES I. LONGENECKER
INVENTOR.

BY *George A. Evans*
ATTORNEY

April 10, 1951

C. I. LONGENECKER

2,548,733

APPARATUS FOR PUMPING CONCRETE

Filed Aug. 29, 1947

3 Sheets-Sheet 3

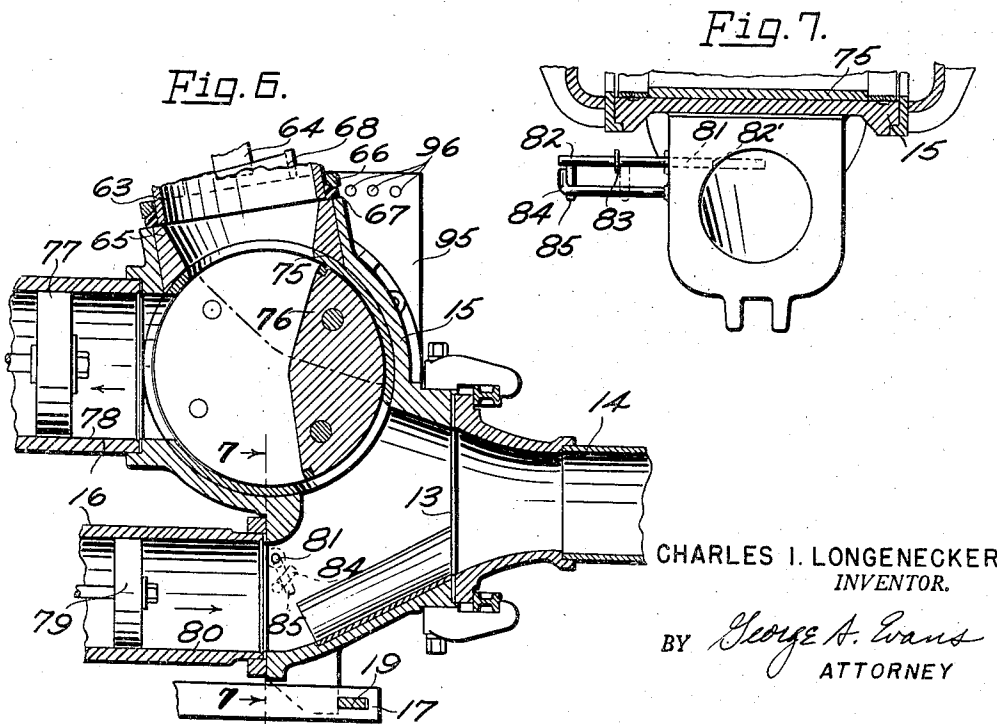
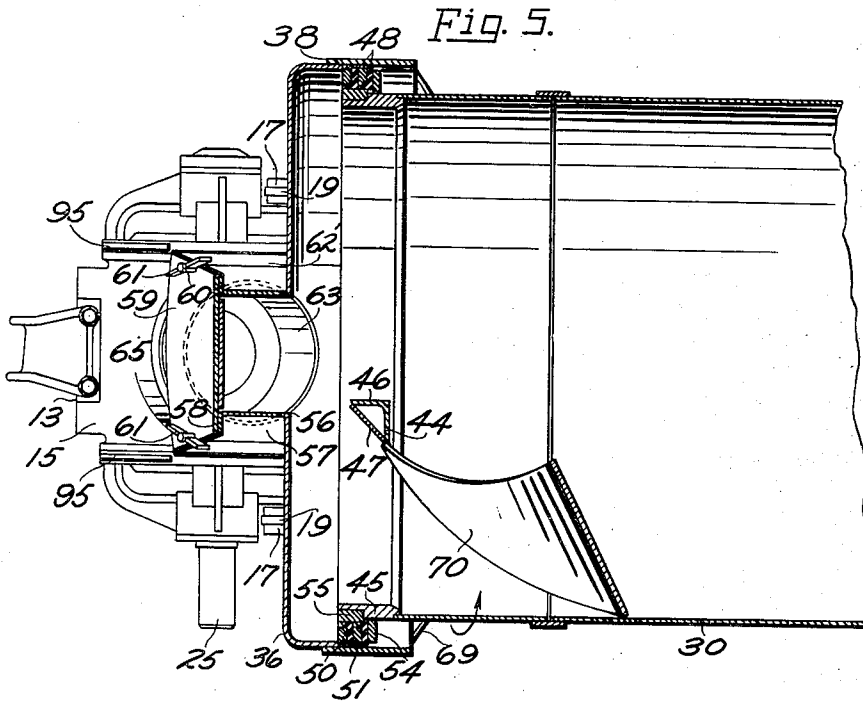

CHARLES I. LONGENECKER
INVENTOR.

BY *George A. Evans*
ATTORNEY

UNITED STATES PATENT OFFICE

2,548,733

APPARATUS FOR PUMPING CONCRETE

Charles I. Longenecker, Wauwatosa, Wis., assignor to Chain Belt Company, Milwaukee, Wis., a corporation of Wisconsin

Application August 29, 1947, Serial No. 771,276

3 Claims. (Cl. 259-161)

1

This invention relates to concrete pumps and particularly to means for maintaining and feeding a supply of concrete to the working chamber of such pumps. The invention has other objects, relating to the improved performance of the pump and resides in the novel disposition and combination of parts as hereinafter set forth.

In the operation of concrete pumps, concrete is frequently brought in transit concrete mixers to the site where the pump is located. These truck mixers can discharge their contents considerably faster than the rate at which the concrete can be pumped, and hence it is desirable to provide storage means communicating with the concrete pump so that the mixers can discharge their contents into the storage means and then depart for another load of concrete.

In order to maintain the concrete in proper plastic condition for pumping while it is being stored, it is desirable that the concrete be agitated. It is also desirable that the point of entry of the concrete into the storage and agitating receptacle be at as low an elevation as possible in order that the truck mixers can discharge their contents directly therein and without the use of elevating means.

Furthermore, it is important in the case of concrete pumps that the concrete as it enters the pump be under some pressure in order that this pressure may facilitate the filling of the piston chamber during the suction stroke of the piston. This is partly due to the fact that concrete does not flow to the same extent as would a highly viscous liquid. Inability to completely fill the piston chamber results in reducing the efficiency of the pump by reducing its capacity. The feed to the pump should also be continuous with the pump inlet completely filled with material so that no air can become trapped in the working chamber of the pump. Should an air pocket be formed in the pump the efficiency is materially reduced.

It is an object of the present invention to provide a storage and agitating receptacle which will meet the requirements hereinbefore enumerated of supplying concrete to the concrete pump in an improved manner.

One embodiment of the invention is illustrated in the accompanying drawings wherein:

Fig. 1 is a side elevation of a concrete pump with its supporting framework and an agitating receptacle mounted thereon;

Fig. 2 is an end view of the upper portion of the apparatus shown in Fig. 1;

Fig. 3 is a section taken on the line 3-3 of Fig. 2;

2

Fig. 4 is an enlarged side elevation partly in section showing the discharge end of the agitating receptacle and the inlet end of the pump;

Fig. 5 is a section taken on line 5-5 of Fig. 4;

Fig. 6 is a vertical section taken through the center of the valve of the pump showing the disposition of the valve and piston chambers; and

Fig. 7 is a section taken on the line 7-7 of Fig. 6.

The concrete pump illustrated in the drawings is of the differential piston type, such as is disclosed in U. S. Patent No. 2,448,104 granted August 31, 1948, on my copending application Serial Number 633,091, filed December 6, 1945, entitled Differential Concrete Pump. Its valve construction is disclosed in my copending application Serial Number 763,328, filed July 24, 1947, entitled Valve for Plastic Concrete Pressure Pump. It will be appreciated, however, that many of the features of this invention are not restricted in their application to use with pumps of any particular construction and can be operated with pumps of widely different types of construction.

The pump illustrated in Fig. 1 of the drawings is mounted on a skid base 11 at one end of which is mounted the engine 12, and at the opposite end of which is located the discharge 13 of the pump to which the pipe line 14 is connected. The valve body 15 is arranged to register with the ends of the piston chambers 16, and said body is detachably supported by forwardly extending brackets 17 which are mounted on a front pedestal 18 through which the piston chambers 16 extend. It will be observed that the valve body 15 is held in position by wedges 19 which are driven through slots in the brackets 17 and which exert force on abutments of the valve body, thereby effecting sealing engagement of the body with the ends of the piston chamber.

The transmission for operating the pistons is enclosed in a housing 20 from one side of which there extends a shaft 21 for operating the oscillating pump valve. The operating means for accomplishing the latter consists of a cam 21' mounted on the crank shaft 21, cam lever 22, connecting rod 23 and valve operating arm 24. The arm 24 is keyed to a trunnion 25 which extends from one side of the valve plug.

At the rearward end of the skid base 11 and on each side thereof are upstanding frame members 26, the upper portions of which are connected by a cross member 27 on which is mounted a pair of laterally spaced brackets 28 each of which supports a bearing for a roller 29. Rollers 29 form a bed for supporting the charging end of the

agitating receptacle 30 and cooperate with a track 31 which surrounds the circumferential body of that receptacle.

The forward end of the agitating receptacle 30 is supported as best illustrated in Figs. 2 and 4 by an axially disposed shaft 32 mounted in a bearing 33. Bearing 33 is housed by a collar 34 bolted to a hub 35 located at the center of the stationary dished head 36. Reinforcing members 37 are welded to the outside of said head to strengthen the same while a rim member 38 secured to the periphery of the head and extending rearwardly of the agitating receptacle 30 constitutes an enclosure for the forward end of the receptacle. Bearing 33 is protected from the concrete in the agitating receptacle by annular sealing members 39 which are mounted in the hub 35 and which bear against shaft 32. A cap 40 fitting on the collar 34 and equipped with a grease fitting 41 encloses the outer end of the shaft 32.

The inner end of shaft 32 is secured to a spider 42 which is connected to the forward end of the agitating drum 30. The spider 42 is of welded construction and consists of a hub 43 having a square periphery to which there are secured the spokes 44 which are connected to the ring member 45 at the end of the receptacle 30. Each spoke 44 comprises an angle member 46, the ends of which are connected by the diagonal plate 47, the function of which will be later explained. The distance between the forward end of the spokes 44 and the head 36 is just sufficient to accommodate the largest stones which the pump is designed to handle, and hence any such stones in the mix may be forced against the head and the receptacle can continue to rotate and clear the stones without danger of breakage or the imposition of excessive power demands.

The diameter of the ring 45 is somewhat smaller than the diameter of the stationary rim 38 in order that a seal may be accommodated between them. This seal, which is of very similar construction to the seal 39 for the shaft 32, comprises a pair of annular deformable members 48 of rubber or other suitable material held in place by a series of circumferentially spaced bolts 49 which are threaded into a backing ring 50 which is welded or otherwise secured to the rim 38. This construction is best illustrated in Fig. 3. Two sealing members 48 are spaced apart by an annular member 51 which is provided with radial apertures at suitable points in its periphery to enable lubricant to be supplied thereto through fittings 52 fed by means of pipes 53 from a source of lubricant supply. The outer of the two rings 48 is retained by the washer 54 against which the heads of the bolts 49 bear. The inner ends of the sealing members 48 have elongated tip portions which bear against an annular insert 55 mounted on the ring 45, and the tip portions of the members 48 are deformed to provide an increased sealing surface against the insert 55.

The head 36 is provided with an aperture 56 directly below the hub 35 which extends from the periphery of the head a distance roughly equal to one-half the radius of said head. The radial sides of the slot 56 taper inwardly toward the center of the head, and on either side thereof and extending forwardly are triangular shaped plates 57 defining the upper sides of a conduit or pressure chamber for the concrete passing from the agitating receptacle to the pump. The forward ends of the plates 57 are enclosed by a frame 58 against which a cover plate 59 is fitted. Bolts 60 extending through the frame 58 and the cover

plate 59 are slotted so that wedges 61 may be driven therethrough to force the plate into sealed engagement with the frame and prevent passage of air into the pump. When the wedges 61 are removed the plate 59 may be lifted from the frame 58, handle 62 being provided to facilitate such removal.

The disposition of the cover plate 57 as provided herein, enables the operator in some instances to discharge the contents of vessel 30 without the latter passing into the pump. This would be done if perchance a bad batch of concrete should be delivered to the agitator and not detected until the blades 70 exert is sufficient to force the concrete through the lateral opening provided in the conduit by removal of the cover plate 59.

The bottom edges of the triangular plates 57 are welded to a horizontal plate 62' having a circular aperture registering with a cylindrical member 63 which leads to the pump inlet. Mounted on either side of the cylindrical member 63 are angle shaped brackets 64. As illustrated in Fig. 6 the end of the cylindrical member 63 is spaced slightly from the inlet end 65 of the valve body of the pump, and surrounding the end of the cylindrical member 63 is a loosely fitting metal ring 66 which rests on a rubber washer 67 which fits tightly around the lower end of the pipe 63. The annular rubber member 67 abuts the edges of the opening 65 and has a tapered upper surface arranged to mate with the complementary taper surface of the ring 66. A tight seal is maintained by driving wedges 68 between the brackets 64 and the ring 66, the outer portion of the rubber member being pressed downwardly against the inlet 65 and the inner surface gripping the conduit 63. The use of rubber in the seal compensates for tolerances that might occur in manufacture which would make it difficult to align the surfaces, since both the valve body and the feeding apparatus are separately mounted on the pump frame.

The head 36 is supported by a vertical plate 68' and by the side plates 69 which are mounted on the frame pedestal 18. This structure not only carries the weight of the forward end of the agitating receptacle 30, but also takes the end thrust which the spiral blades 70 in the receptacle exert on material being forced against the end plate 36.

As illustrated in Fig. 5, the spiral blade 70 joins the forward side of the spoke 44 and is securely fastened thereto. The diagonal face 47 of the spoke has a propulsive effect similar to that of the blade and forces the concrete under considerable pressure through the slot 56 and hence into the pump. The receptacle illustrated is provided with two spiral blades set 180° apart connected to two of the four spokes in the spider 42. When the drum is rotated in the direction indicated by the arrow shown in the drawings, blades 70 which extend for the full length of the drum 30 are arranged to propel the concrete 65 which is introduced at the rearward end of the drum to the forward end. The height of the blades 70 adjacent the discharge opening is substantially the same as the height of the opening 56 in order that pressure may be exerted on the concrete across the full cross sectional area of the opening as the drum is rotated and the end of the blade passes the opening. A chute 71 mounted at the rear end of the drum facilitates transfer into the drum, and the drum is rotated by a chain 72 meshing with a sprocket 73 mount-

5

ed on the drum a slight distance forwardly of the track 31. The power to drive the chain may be derived from a sprocket 74 driven by the same source of power as is used to operate the concrete pump.

As previously mentioned the concrete may be charged into the receptacle 30 faster than the pump can take it away, and in this event the concrete will pile up at the discharge end of the receptacle, assuming it be constantly rotated, until the level of concrete at the head 36 may be above the shaft 32. Should there be an interruption in pumping which is not unduly long, the concrete in the receptacle is continuously agitated and maintained in the plastic condition.

No agitation is provided within the conduit leading from the agitating receptacle to the pump. Should the material in this conduit become unpumpable for any reason, it may be removed from the conduit by removal of the cover plate 59. In most instances, however, upon resumption of pumping operations, the suction of the pump augmented by the pressure of the blades 70 is sufficient to move into the pump the concrete which has not been stagnant too long in the conduit leading from the agitator to the pump.

A section through the valve body 15 is illustrated in Fig. 6 according to which the inlet 65 communicates through a port in the valve liner 75 with the valve chamber. The segmental plug valve 76 is arranged to oscillate from the full line position shown in Fig. 6 to the dotted line position shown in said figure. In the full line position shown the position 77 in the cylinder 78 is exerting suction and drawing concrete through the inlet 65 from the agitating receptacle. The aggregates are heaped high at the discharge end of the agitating drum 30 and, as previously pointed out, the blades 70 are assisting in forcing concrete into the cylinder 78. At the end of the suction stroke of the piston 77, the valve shifts to the dotted line position shutting off the inlet and exposing the port in the liner 75 which leads to the outlet. The piston 77 now expels the concrete through this port, but instead of all of the concrete going into the pipe line 14, the use of the smaller piston 79 provides for a portion of this concrete entering the chamber 80 in which the smaller piston operates. During the propulsion stroke of the larger piston 77 the smaller piston draws concrete into its chamber, which it expels into the pipe line when the valve returns to its original, full line position.

At the start of operations with the concrete pump, whatever air is in the valve appears to collect in the upper portion of the smaller piston chamber 80 instead of being expelled into the pipe line. This results in the smaller piston chamber not being filled with concrete and the full advantages of the differential piston arrangement are not obtained. To get the original air out of the valve an aperture or air-exhaust port 81 is formed in the side wall of the valve body just in front of the lower piston cylinder 80 and near the top thereof. A rod 82 which fits snugly in this port is arranged to extend, when fully inserted, so that its inner end 82' is approximately in line with the vertical axis of the piston 79. A washer 83 limits the extent to which this rod may be inserted into the working chamber of the pump. The rod 82 is prevented from being forced out of the chamber by a keeper 84 which engages a handle 85 on the rod. At the start of operation,

6

however, and in order to get the air out of the chamber the rod may be turned, thus freeing the handle 85 from the keeper 84 and permitting removal of the rod. Often concrete may cover the inner end of the port 81 and hence it is provided that the rod may be moved inwardly to the dotted line position shown in Fig. 7 in order to provide a channel through the obstructing concrete between the air pocket and the port through which the air may escape when the rod is removed. It requires only a short time to remove the air from the cylinder, after which the rod is relocated in the aperture 81 and pumping may proceed without air trouble.

In large concrete pumping jobs it is desirable to be able to pump practically continuously because any shutdown necessitates cleaning out the pump and pipe line, or else the concrete will set. The present pump is designed so that in case some portions of the valve become worn or need repair, the entire valve body can be removed and a stand-by valve body which is on hand substituted without requiring a clean-out of the pipe line. This latter operation is facilitated by the provision of a boom 86 pivotally mounted for horizontal movement in a bearing housed in a bracket 87 mounted on the end plate 36 of the storage receptacle. A carriage 88 which may traverse the boom 86 carries a block and tackle designated 89, the hook 90 of which can be inserted in a hook 91 mounted on the upper portion of the valve body to permit the lifting and removal of the valve body from the pump. To balance the weight of the valve body on the hook 90, the hook 91 is secured to a cross bar 92, the ends of which are pivotally connected through turnbuckles 93 and bolts 94 to upstanding members 95 on either side of the valve body, as illustrated in Fig. 2. In Fig. 1, members 95 are illustrated as provided with a plurality of apertures 96 affording choice in the selection of holes through which the bolts 94 are inserted. As a result the yoke formed by the cross bar 92 and the turnbuckles 93 may be set at a slight angle to the axis of the valve, so that the bar may intersect the center of gravity of the valve body. This facilitates aligning the body with ends of the piston chambers.

The upper portion of the head 36 is cut away at 97, as illustrated in Fig. 2, in order that the pumpability of the concrete being fed into the pump may be observed. The cover plate 59 may likewise be removed, as previously explained, to facilitate clean-out or loosening of any obstructions that may occur in the inlet portion of the pump.

The invention having been described what is claimed is:

1. Apparatus for maintaining and feeding a supply of plastic concrete to a pump comprising a frame, a stationary substantially vertical head having an aperture in its lower portion, said head being mounted on said frame, a conduit providing communication between said aperture and said pump, a rotatable receptacle in sealing engagement with said head, said receptacle having agitating means mounted therein arranged to propel the concrete under pressure through said conduit, a bearing disposed centrally of and supported by said head, and a spider mounted on said bearing and connected to the discharge end of said receptacle, the legs of said spider being spaced axially from said head and having a sloping face arranged to assist said agitating means in propelling concrete through said aperture during rotation of the receptacle.

7

2. Apparatus for storing, agitating, and pressurally feeding a plastic concrete mixture to the inlet passage of a concrete pump without the formation of air pockets therein, said apparatus comprising a horizontally disposed cylindrical receptacle mounted for rotation about its longitudinal axis and having an opening in one end through which said mixture may be charged; a stationary vertical head engaging and closing the other end of said receptacle, and having a discharge opening disposed eccentrically of the receptacle axis; a closed conduit extending from said discharge opening for attachment to the inlet passage of the pump; a helical blade carried by the inner periphery of the receptacle, for agitating the concrete mixture therein and moving it toward and piling it up against said stationary head to a level above said opening, said blade terminating adjacent the head in a substantially flat portion disposed at an angle to the plane of said discharge opening and positioned to sweep past such opening, whereby to pressurally force the mixture therethrough and through said conduit and inlet passage of the pump without air pockets therein; and means for rotating said receptacle and blade.

3. Apparatus for storing, agitating, and pressurally feeding a plastic concrete mixture to the inlet passage of a concrete pump without the formation of air pockets therein, said apparatus comprising a horizontally disposed cylindrical receptacle mounted for rotation about its longitudinal axis and having an opening in one end through which said mixture may be charged; a stationary vertical head engaging and closing the other end of said receptacle, and having a

8

discharge opening in its lowest sector adjacent the periphery of the receptacle; a closed conduit extending from said discharge opening for attachment to the inlet passage of the pump; a helical blade extending inwardly from the inner periphery of the receptacle, for agitating the concrete mixture therein and moving it longitudinally toward and piling it up against said stationary head to a level above said opening, said blade terminating adjacent the head in a substantially flat portion disposed at an angle to the head and positioned to sweep past the fixed discharge opening therein, whereby to pressurally force the mixture therethrough and through said conduit and inlet passage of the pump without air pockets therein, the terminus of said blade being spaced from the head a distance at least equal to the size of the largest aggregate in the mixture whereby to avoid jamming of such aggregates between the blade and head; and means for rotating said receptacle and blade.

CHARLES I. LONGENECKER.

REFERENCES CITED

The following references are of record in the file of this patent:

UNITED STATES PATENTS

Number	Name	Date
778,878	Moir	Jan. 3, 1905
1,616,783	Calkins	Feb. 8, 1927
2,131,681	Ball	Sept. 27, 1938
2,254,639	Andrae	Sept. 2, 1941
2,344,698	Howe	Mar. 21, 1944
2,360,345	Hilkemeier	Oct. 17, 1944
2,394,453	Huszar	Feb. 5, 1946