

**(12) STANDARD PATENT**  
**(19) AUSTRALIAN PATENT OFFICE**

(11) Application No. **AU 2022398696 B2**

(54) Title  
**REEL SEAT GRIP MEMBER, REEL SEAT GRIP STRUCTURE, AND FISHING ROD**

(51) International Patent Classification(s)  
**A01K 87/08** (2006.01)                      **A01K 87/06** (2006.01)

(21) Application No: **2022398696**                      (22) Date of Filing: **2022.10.14**

(87) WIPO No: **WO23/095483**

(30) Priority Data

(31) Number	(32) Date	(33) Country
<b>2021-190437</b>	<b>2021.11.24</b>	<b>JP</b>

(43) Publication Date: **2023.06.01**

(44) Accepted Journal Date: **2025.06.26**

(71) Applicant(s)  
**GLOBERIDE, INC.**

(72) Inventor(s)  
**KAWAMURA Takuji;NAKAGAWA Keisuke**

(74) Agent / Attorney  
**Griffith Hack, Level 15 376-390 Collins St, MELBOURNE, VIC, 3000, AU**

(56) Related Art  
**WO 2023/002654 A1**  
**JP 2020162513 A**  
**JP 6691842 B2**

(12) 特許協力条約に基づいて公開された国際出願

(19) 世界知的所有権機関  
国際事務局

(43) 国際公開日  
2023年6月1日(01.06.2023)



(10) 国際公開番号

**WO 2023/095483 A1**

- (51) 国際特許分類:  
*A01K 87/08* (2006.01) *A01K 87/06* (2006.01)
- (21) 国際出願番号: PCT/JP2022/038346
- (22) 国際出願日: 2022年10月14日(14.10.2022)
- (25) 国際出願の言語: 日本語
- (26) 国際公開の言語: 日本語
- (30) 優先権データ:  
特願 2021-190437 2021年11月24日(24.11.2021) JP
- (71) 出願人: グローブライド株式会社(GLOBERIDE, INC.) [JP/JP]; 〒2038511 東京都東久留米市前沢3丁目14番16号 Tokyo (JP).
- (72) 発明者: 川村 拓司 (KAWAMURA Takuji); 〒2038511 東京都東久留米市前沢3丁目14番16号 グローブライド株式会社内 Tokyo (JP).  
中川 敬介 (NAKAGAWA Keisuke); 〒2038511 東京都東久留米市前沢3丁目14番16号 グローブライド株式会社内 Tokyo (JP).
- (74) 代理人: 今村 光広 (IMAMURA Mitsuhiro); 〒1056328 東京都港区虎ノ門1-23-1 虎ノ門ヒルズ森タワー28階 K & L G A T E S 外国法共同事業法律事務所 Tokyo (JP).
- (81) 指定国(表示のない限り、全ての種類の国内保護が可能): AE, AG, AL, AM, AO, AT, AU, AZ, BA, BB, BG, BH, BN, BR, BW, BY, BZ, CA, CH, CL, CN, CO, CR, CU, CV, CZ, DE, DJ, DK, DM, DO,

(54) Title: REEL SEAT GRIP MEMBER, REEL SEAT GRIP STRUCTURE, AND FISHING ROD

(54) 発明の名称: リールシートグリップ部材、リールシートグリップ構造及び釣竿

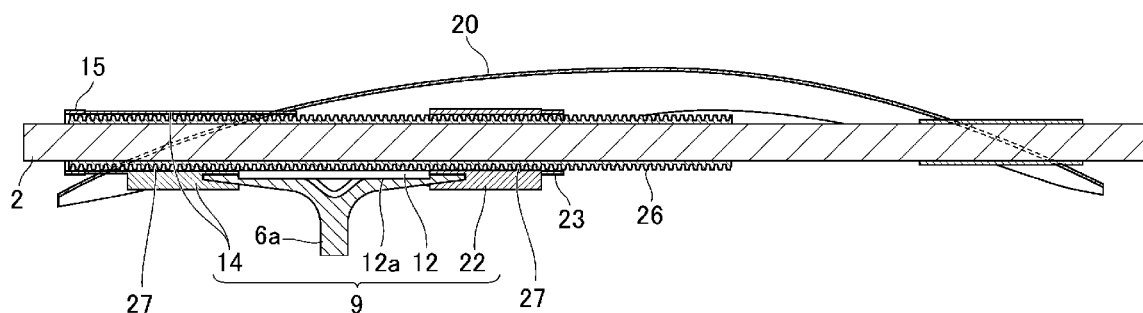

(57) Abstract: Provided are a reel seat grip member, reel seat grip structure, and fishing rod, wherein not only size reduction of a hood and weight reduction but also a high degree of freedom in the design is achieved. A reel seat grip member according to one embodiment of the present invention is provided with a fairing part and a butt part connected to the fairing part. The fairing part has one end mounted to at least one of a pair of hoods that are provided on a rod body and used for fixing a reel leg. The butt part has one end mounted to the rod body via a mounting member provided on



WO 2023/095483 A1

DZ, EC, EE, EG, ES, FI, GB, GD, GE, GH, GM, GT, HN, HR, HU, ID, IL, IN, IQ, IR, IS, IT, JM, JO, KE, KG, KH, KN, KP, KR, KW, KZ, LA, LC, LK, LR, LS, LU, LY, MA, MD, MG, MK, MN, MW, MX, MY, MZ, NA, NG, NI, NO, NZ, OM, PA, PE, PG, PH, PL, PT, QA, RO, RS, RU, RW, SA, SC, SD, SE, SG, SK, SL, ST, SV, SY, TH, TJ, TM, TN, TR, TT, TZ, UA, UG, US, UZ, VC, VN, WS, ZA, ZM, ZW.

- (84) 指定国(表示のない限り、全ての種類の広域保護が可能): ARIPO (BW, CV, GH, GM, KE, LR, LS, MW, MZ, NA, RW, SD, SL, ST, SZ, TZ, UG, ZM, ZW), ユーラシア (AM, AZ, BY, KG, KZ, RU, TJ, TM), ヨーロッパ (AL, AT, BE, BG, CH, CY, CZ, DE, DK, EE, ES, FI, FR, GB, GR, HR, HU, IE, IS, IT, LT, LU, LV, MC, ME, MK, MT, NL, NO, PL, PT, RO, RS, SE, SI, SK, SM, TR), OAPI (BF, BJ, CF, CG, CI, CM, GA, GN, GQ, GW, KM, ML, MR, NE, SN, TD, TG).

添付公開書類:

一 国際調査報告 (条約第21条(3))

---

the rod body.

(57) 要約: 軽量かつフードのコンパクト化のみならず、デザインの自由度が高い、リールシートグリップ部材、リールシートグリップ構造及び釣竿を提供することにある。本発明の一実施形態に係るリールシートグリップ部材は、フェアリング部と、該フェアリング部に接続された尻部と、を備え、該フェアリング部は、その一方の端部が竿体に設けられたリール脚を固定するための一对のフードの内少なくとも一方のフードに取付けられ、該尻部は、その一方の端部が該竿体に設けられた取付部材を介して該竿体に取り付けられるように構成される。

REEL SEAT GRIP MEMBER, REEL SEAT GRIP STRUCTURE, AND FISHING ROD

Technical Field

[0001]

Cross Reference

The present application claims priority based on Japanese Patent Application No. 2021-190437 (filed on November 24, 2021), the contents of which are incorporated herein by reference in their entirety.

The present invention relates to a reel seat grip member, a reel seat grip structure, and a fishing rod comprising any one of a reel seat grip member and a reel seat grip structure.

Background Art

[0002]

In the related art, various fishing rods each including a fishing rod reel seat and a grip have been known.

[0003]

In such a fishing rod, a fishing rod reel seat and a fishing rod grip are usually placed on a rod body, and a reel leg placing portion for placing a reel leg on an upper side or a lower side of a main body is formed on the fishing rod reel seat.

[0004]

As such a fishing rod, for example, Patent Literature 1 discloses a fishing rod including: a rod body; a cylindrical reinforcing resin layer formed on a circumferential surface of the rod body and having an uneven surface formed on an outer periphery thereof; and a reel

seat injection-molded on an outer circumferential surface of the reinforcing resin layer.

[0005]

In addition, Patent Literature 2 discloses a fishing rod including a rear grip portion on a rear side of a reel seat including a cylindrical reel seat main body having a reel leg placing portion on which a leg portion of a reel is placed, the fishing rod including: a rod main body; and a rear grip rod body in which a rear grip portion is integrally formed by increasing the diameter of a rear portion of a hollow rod body at a diameter change rate larger than a diameter change rate of the rod main body at the time of forming the hollow rod body from a prepreg, in which a rear portion of the rod main body and a front portion of the rear grip rod body are overlapped and joined integrally with each other inside and outside so as to form an overlapping portion having a predetermined length, and at least a part of the overlapping portion is located inside the reel seat main body.

#### Citation List

##### Patent Literature

[0006]

Patent Literature 1: JP H11-137132 A

Patent Literature 2: JP 2013-21923 A

[0007]

However, in the fishing rod disclosed in Patent Literature 1, since the solid reel seat injection-molded on an outer peripheral surface of a cylindrical reinforcing resin layer is disposed on the reinforcing resin layer in the rod body, there is a problem that the weight

increases and the size is huge.

[0008]

In addition, in the fishing rod disclosed in Patent Literature 2, since the rear grip rod body and the reel seat main body are joined to the rod main body, there is a problem that an increase in weight for bonding is unavoidable.

[0009]

The present invention has been made in view of the above circumstances. It would be desirable to provide a reel seat grip member, a reel seat grip structure, and a fishing rod that are lightweight, have a compact hood, and have a high degree of freedom in design. Other aspects of the present invention will become apparent upon reference to the entirety of the present specification.

#### Summary of The Invention

[0010]

The present invention provides a reel seat grip member comprising: a fairing portion; and a rearward portion connected to the fairing portion, wherein the fairing portion is attached at one end of the fairing portion to at least one hood of a pair of hoods provided on a rod body for fixing a reel leg, and the rearward portion is attached at one end of the rearward portion to the rod body via an attachment member provided on the rod body, and wherein the rearward portion is attached to an area of the rod body between the at least one hood of the pair of hoods, and a rear end of the rod body.

[0011]

In the reel seat grip member according to the embodiment of the present invention,

the fairing portion is attached to the at least one hood by adhesion, fitting, or mechanical fastening.

[0012]

In the reel seat grip member according to the embodiment of the present invention, the rearward portion is attached to the attachment member by adhesion, fitting, or mechanical fastening.

[0013]

In the reel seat grip member according to some embodiments of the present invention, the fairing portion and the rearward portion may be rigidly fixed to the rod body. In some embodiments, the fairing portion and the rearward portion may be movable mounted to the rod body.

[0014]

In the reel seat grip member according to the embodiment of the present invention, in a case where the fairing portion and the rearward portion are fixed to the rod body, the at least one hood and the attachment member are fixed to the rod body by adhesion, fitting, or mechanical fastening.

[0015]

In the reel seat grip member according to the embodiment of the present invention, in a case where the fairing portion and the rearward portion are fixed to the rod body to be movable, the at least one hood and the attachment member are movable with respect to the rod body in an axial direction of the rod body.

[0016]

In the reel seat grip member according to the embodiment of the present invention,

the at least one hood and the attachment member are movable with respect to the rod body in the axial direction of the rod body such that inner peripheral surfaces of the at least one hood and the attachment member are screwed into an outer peripheral surface of the rod body.

[0017]

In the reel seat grip member according to the embodiment of the present invention, the fairing portion and the rearward portion are integrally formed by carbon fiber reinforced plastic.

[0018]

In the reel seat grip member according to the embodiment of the present invention, one or a plurality of notches is formed in a part of the reel seat grip member. In addition, in the reel seat grip member according to the embodiment of the present invention, one or a plurality of honeycomb structures is formed in a part of the reel seat grip member.

[0019]

A reel seat grip structure according to another embodiment of the present invention comprises any one of the reel seat grip members described above, a pair of hoods for fixing a reel leg provided on a rod body, and an attachment member for attaching the reel seat grip member to the rod body.

[0020]

A fishing rod according to still another embodiment of the present invention comprises a rod body, any one of the reel seat grip members described above, a pair of hoods for fixing a reel leg provided on the rod body, and an attachment member for attaching the reel seat grip member to the rod body.

## Advantageous Effects of Invention

[0021]

According to the embodiments of the invention, it is possible to provide the reel seat grip member, the reel seat grip structure, and the fishing rod that are lightweight, have a compact hood, and have a high degree of freedom in design.

## Brief Description of Drawings

[0022]

Fig. 1 is a diagram illustrating a fishing rod according to an embodiment of the present invention.

Fig. 2 is a diagram for describing a fishing rod reel seat according to the embodiment of the present invention.

Fig. 3 is a diagram for describing a reel seat grip member according to the embodiment of the present invention.

Fig. 4 is a cross-sectional view of the reel seat grip member according to the embodiment of the present invention.

Fig. 5 is a top view of the reel seat grip member according to the embodiment of the present invention.

Fig. 6 is a diagram for describing the reel seat grip member according to the embodiment of the present invention.

Fig. 7A is a side view of the reel seat grip member according to the embodiment of the present invention. Fig. 7B is a top view of the reel seat grip member according to the

embodiment of the present invention.

Fig. 8A is a side view of the reel seat grip member according to the embodiment of the present invention. Fig. 8B is a top view of the reel seat grip member according to the embodiment of the present invention.

#### Description of Embodiments

[0023]

Hereinafter, an embodiment of a fishing rod according to the present invention will be specifically described with reference to the attached drawings. Components common in a plurality of drawings are assigned with the same reference signs throughout the plurality of drawings. It should be noted that each drawing is not necessarily drawn to an accurate scale for the sake of convenience in description.

[0024]

Fig. 1 is a diagram illustrating an embodiment of the fishing rod according to the present invention. As illustrated in the drawing, a fishing rod 1 according to the embodiment of the present invention comprises a rod body 2, a reel 6 attached to the rod body 2 via a reel seat 9, and a fishing line guide 10 attached to the rod body 2. In the illustrated embodiment, the reel seat 9 and the fishing line guide 10 each correspond to an attachment component attached to an outer peripheral surface of the rod body.

[0025]

The rod body 2 is constituted by, for example, connecting a base rod 3, a middle rod 5, a tip rod 7, and the like to each other. These rod bodies are jointed to each other, for example, as an ordinarily jointed type. The base rod 3, the middle rod 5, and the tip rod 7

can be jointed to each other as a telescopic type, an inversely jointed type, a socket-and-spigot jointed type, or any other known jointed type. The rod body 2 may be formed of a single rod body.

[0026]

Each of the base rod 3, the middle rod 5, and the tip rod 7 is formed of, for example, a tubular body made of a fiber-reinforced resin. This tubular body made of a fiber-reinforced resin is formed by winding a fiber-reinforced resin prepreg (prepreg sheet) in which reinforcing fibers are impregnated with a matrix resin around a core metal, and heating and curing the prepreg sheet. As the reinforcing fibers contained in the prepreg sheet, for example, carbon fibers, glass fibers, and any other known reinforcing fibers can be used. As the matrix resin contained in the prepreg sheet, a thermosetting resin such as an epoxy resin can be used. After the prepreg sheet is cured, the core metal is removed. In addition, an outer surface of the tubular body is appropriately polished. Each of the rod bodies may be formed in a solid state.

[0027]

In the illustrated embodiment, the base rod 3, the middle rod 5, and the tip rod 7 comprise a plurality of the fishing line guides 10 (fishing line guides 10A to 10D) for guiding a fishing line fed from the reel 6 attached to the reel seat 9. More specifically, the base rod 3 comprises the fishing line guide 10A, the middle rod 5 comprises the fishing line guide 10B, and the tip rod 7 comprises the fishing line guide 10C. The tip rod 7 comprises the top guide 10D at a distal end thereof, but details thereof are omitted.

[0028]

Next, examples of a reel seat main body 12 and the reel seat 9 will be described with reference to Fig. 2. The reel seat 9 comprises the reel seat main body 12 having a reel

leg placing surface 12a on which a reel leg 6a of the fishing reel 6 is placed in an axial direction thereof. In the illustrated example, the reel seat main body 12 is provided in a predetermined portion of the fishing rod 1 without a gap between a pair of moving hoods (a first moving hood 14 on a rod tip side and a second moving hood 22 on a rod rearward side) to be described below in order to support the reel leg, but may be formed with a predetermined length between the first moving hood 14 and the second moving hood 22 so as to support a part of the reel leg. Note that, although at least one of the pair of moving hoods may be a fixing hood, the pair of moving hoods (also referred to as floating hoods) will be described in the present specification.

[0029]

In addition, although not illustrated, the reel seat main body 12 may be formed so as to surround the rod body 2. The reel seat main body 12 can be configured to have a length of 60 to 160 mm, for example, but is not limited thereto. Various forms, dimensions, and shapes other than these are conceivable for the reel seat main body 12, and the reel seat main body 12 is not limited to a specific aspect.

[0030]

The reel leg placing surface 12a of the reel seat main body 12 can be formed flat or substantially flat, and the reel seat main body 12 illustrated in Fig. 2 is formed in a state of extending in an axial direction of the rod body 2. In the illustrated example, as described above, the first moving hood 14 is disposed at one end (rod tip side) of the reel seat main body 12. At least one end of the reel leg placing surface 12a of the reel seat main body 12 may be disposed inside the first moving hood 14 or the second moving hood 22.

[0031]

The second moving hood (also referred to as a floating hood) 22 is attached to the

other end side (rod base side) of the reel seat main body 12 so as to be movable in an axial direction. A second nut portion 23 is provided in order to move the second moving hood 22. Similarly, a first nut portion 15 is provided to move the first moving hood 14 described above. The reel seat main body 12, the first moving hood 14, the second moving hood 22, the first nut portion 15, and the second nut portion 23 may be referred to as the reel seat 9, but details thereof are omitted. As will be described later, a configuration without the reel seat main body 12 is also conceivable.

[0032]

Here, the reel seat main body 12 can be formed to support the reel leg 6a on the reel leg placing surface of the reel seat main body such that both ends are supported by the first moving hood 14 and the second moving hood 22. On the other hand, there is no reel seat main body 12, and the reel leg 6a may be formed such that both ends of the reel leg 6a is supported by the fixing hood 14 and the moving hood 22.

[0033]

In addition, in the fishing rod 1 having a reel seat grip member 20 according to the embodiment of the present invention, the reel seat main body 12 on which the reel leg 6a is placed may be formed on the rod body 2. In addition, in the fishing rod 1 having the reel seat grip member 20 according to the embodiment of the present invention, the reel seat main body 12 on which the reel leg 6a is placed may be provided between the fixing hood 14 and the moving hood 22 of a pair of hoods 13, and the reel seat main body 12 and the hood 13 may be integrally formed.

[0034]

Next, the reel seat grip member 20 according to the embodiment of the present invention will be described with reference to Figs. 3, 4, and 5. Here, the reel seat grip

member 20 is a member that comprises a fairing portion 40 and a rearward portion 50 of the fishing rod 1, which are formed with ranges of A and B illustrated in Fig. 3, and that is intended to impart a grasping property of the fishing rod. Note that, the reel seat grip member 20 can be formed of the portion corresponding to only the fairing portion 40 of the reel seat grip member 20, that is, only the portion corresponding to the range of A illustrated in Fig. 3. In addition, a reel seat grip structure 30 to be described later is a member that has a mechanism for attaching the reel and is intended to facilitate gripping of the fishing rod. Note that, the fairing portion 40 (portion of A) means a front side (foregrip) of the reel seat grip member, and the rearward portion 50 (portion of B) means a grip (middle grip) in the middle of the reel seat grip member.

[0035]

The reel seat grip member 20 according to the embodiment of the present invention comprises the fairing portion 40 and the rearward portion 50 connected to the fairing portion 40. The fairing portion 40 is attached at one end of the fairing portion (an end on a left side of the drawing of Fig. 3) to at least one hood (first moving hood 14) of the pair of hoods 13 provided on the rod body 2 for fixing the reel leg 6a provided on the rod body 2, and the rearward portion 50 is attached at one end of the rearward portion (an end on a right side of the drawing of Fig. 3) to the rod body 2 via the attachment member 25 provided on the rod body 2.

[0036]

According to the reel seat grip member 20 according to the embodiment of the present invention, it is possible to provide a reel seat grip member that is lightweight, has a compact hood, and has a high degree of freedom in design. More specifically, different members can be used for the fairing portion and a rear grip (refers to a grip at a rear end of the

fishing rod and is similar throughout the present description), and a rod tube portion between the fairing portion and a rear grip portion can be decorated.

[0037]

In addition, in the reel seat grip member 20 according to the embodiment of the present invention, the fairing portion 40 is attached to the at least one hood (first moving hood 14) by adhesion, fitting (for example, fitting by press-fitting), or mechanical fastening (for example, mechanical fastening by fastening or fitting using a screw (a method for mechanically detachably fixing by using a movable rib or the like)). In this manner, it is possible to move the hood and the fairing portion as one member.

[0038]

In addition, in the reel seat grip member 20 according to the embodiment of the present invention, the rearward portion 50 is attached to the attachment member 25 by adhesion, fitting (for example, fitting by press-fitting), or mechanical fastening (for example, mechanical fastening by fastening or fitting using a screw (a method for mechanically detachably fixing by using a movable rib or the like)). In this manner, a sliding portion and an attachment portion are provided at two portions together with a portion sliding on the rod body via the hood on the front side of the fairing portion, and thus, the entire reel seat can be stably fixed to the rod body.

[0039]

In the reel seat grip member 20 according to the embodiment of the present invention, the fairing portion 40 and the rearward portion 50 are fixed to the rod body 2 or fixed to the rod body 2 to be movable. In this manner, it is possible to use reel seat grip members having various grip lengths in accordance with the user's preference.

[0040]

In the reel seat grip member 20 according to the embodiment of the present invention, in a case where the fairing portion 40 and the rearward portion 50 are fixed to the rod body 2 (without being movable), the at least one hood 13 and the attachment member 25 are fixed to the rod body by adhesion, fitting (for example, fitting by press-fitting), or mechanical fastening (for example, mechanical fastening performed by fastening or fitting using a screw (a method for mechanically detachably fixing by using a movable rib or the like)). In this case, the first moving hood 14 which is at least one hood 13 serves as the fixing hood, and the fixing hood is fixed without being movable with respect to the rod body 2. In this manner, the fairing portion 40 and the rearward portion 50 are fixed to at least one hood 13 (without being movable) and the attachment member 25 fixed (without being movable) to the rod body 2, respectively, and thus, the fairing portion 40 and the rearward portion 50 can be fixed to the rod body 2 (without being movable). Note that, even though the first moving hood 14 which is at least one hood 13 is used as the fixing hood, since the second moving hood 22 can move back and forth in the axial direction of the rod body 2, the reel leg can be fixed and released.

[0041]

In the reel seat grip member 20 according to the embodiment of the present invention, in a case where the fairing portion 40 and the rearward portion 50 are fixed to the rod body 2 to be movable (in a case where both the fairing portion and the rearward portion are fixed to be relatively movable), the at least one hood 13 and the attachment member 25 are movable with respect to the rod body 2 in the axial direction of the rod body 2. In this manner, fixing positions of the fairing portion 40 and the rearward portion 50 to the rod body 2 can be freely set and changed, and operability of the reel seat grip member 20 can be

improved. In addition, since the fairing portion and the rearward portion can be fixed at various positions, the degree of freedom in design of the reel seat grip member 20 can be increased.

[0042]

As illustrated in Figs. 2, 3, and 4, in the reel seat grip member 20 according to the embodiment of the present invention, the at least one hood 13 and the attachment member 25 (not illustrated) are movable with respect to the rod body 2 in the axial direction of the rod body 2 such that inner peripheral surfaces of the at least one hood 13 and the attachment member 25 are screwed to the outer peripheral surface of the rod body 2. In the examples illustrated in Figs. 2, 3, and 4, a male screw portion 26 is formed on the outer peripheral surface of the rod body, and a female screw portion 27 (illustrated only in Fig. 2) is formed on inner peripheral surfaces of the first moving hood 14 and the second moving hood 22. In this manner, when a reel seat position is changed in accordance with the user's preference, the reel seat position can be fixed by using a screw mechanism.

[0043]

In addition, as illustrated in Fig. 6, in the reel seat grip member 20 according to the embodiment of the present invention, the at least one hood 13 and the attachment member 25 (not illustrated) are formed in a cylindrical shape or a substantially cylindrical shape such that the inner peripheral surfaces of the at least one hood 13 and the attachment member 25 come into contact with the outer peripheral surface of the rod body 2, and the at least one hood 13 and the attachment member 25 are fixed to the outer peripheral surface of the rod body 2 by using a ring-shaped member 28. The ring-shaped member 28 is removed, and thus, the at least one hood 13 and the attachment member 25 are movable with respect to the rod body 2 in the axial direction of the rod body 2. The ring-shaped member 28 is attached again after

moving to a desired position, and thus, the at least one hood 13 and the attachment member 25 can be fixed to the outer peripheral surface of the rod body 2. In this manner, the position of the reel seat is firmly fixed, and can be stably used.

[0044]

In the reel seat grip member 20 according to the embodiment of the present invention, the fairing portion 40 and the rearward portion 50 are integrally formed by carbon fiber reinforced plastic (CFRP). In addition, continuous fiber (CFRTP), discontinuous fiber (CFRTP), or a hybrid may be used as a material of the reel seat grip member 20. The reel seat grip member is made of such a material, and thus, it is possible to suppress an increase in weight while ensuring sufficient rigidity and strength as the reel seat grip member 20 used for the fishing rod.

[0045]

A length (longitudinal length) of the reel seat grip member 20 according to the embodiment of the present invention is 100 to 400 mm.

[0046]

In addition, as illustrated in Fig. 7, in the reel seat grip member 20 according to the embodiment of the present invention, one or a plurality of notches (in the illustrated example, one notch 21) are formed in a part of the reel seat grip member 20. In this manner, it is possible to significantly reduce the weight.

[0047]

In addition, as illustrated in Fig. 8, in the reel seat grip member 20 according to the embodiment of the present invention, one or a plurality of honeycomb structures (in the illustrated example, one honeycomb structure 24) are formed in a part of the reel seat grip

member 20. In this manner, it is possible to reduce the weight while maintaining necessary strength.

[0048]

The reel seat grip structure 30 according to the embodiment of the present invention comprises the reel seat grip member 20 according to the embodiment of the present invention described above, the pair of hoods 13 for fixing the reel leg 6a provided on the rod body 2, and the attachment member 25 for attaching the reel seat grip member 20 to the rod body 2. When such a reel seat grip structure 30 is formed to be detachable from the rod body 2, the reel seat grip structure can be attached to various rod bodies 2, and various reel seat grip structures can be selected and attached to the rod body 2. Accordingly, the degree of freedom in design can be greatly improved.

[0049]

The fishing rod 1 according to the embodiment of the present invention comprises the rod body 2, the reel seat grip member 20 according to the embodiment of the present invention described above, the pair of hoods 13 for fixing the reel leg 6a provided on the rod body 2, and the attachment member 25 for attaching the reel seat grip member 20 to the rod body 2.

[0050]

According to the fishing rod according to the embodiment of the present invention, it is possible to provide a fishing rod comprising the reel seat grip member that is lightweight, has a compact hood, and has a high degree of freedom in design. More specifically, different members can be used for the fairing portion and the rear grip portion, and the rod tube portion between the fairing portion and the rear grip portion can be decorated.

[0051]

The reel seat grip member 20 according to the embodiment of the present invention is configured such that the fairing portion 40 surrounds the nut portion 23 in a range of 50% to 80% in a circumferential direction of the nut portion 23 of the second moving hood 22. In this manner, the reel seat grip member can reduce contact of a hand of an angler with the nut portion of the moving hood during operation of the fishing rod to make the nut portion less likely to loosen. It has been found that such a numerical range is required not only in terms of easiness of gripping of the grip portion but also in order to cover the nut portion of the moving hood for tightening (fixing) the reel leg portion such that a hand or a finger does not touch the nut portion when the grip portion is gripped. It has been found that particularly when 50% or more of the nut portion in the circumferential direction is covered with the grip portion at the time of gripping the grip portion with a hand, the grip portion has a high effect of preventing a gripping finger from touching the nut portion of the moving hood.

[0052]

In addition, the reel seat grip member 20 according to the embodiment of the present invention is configured to extend such that the rod body is surrounded in a range of 20% to 80% in a circumferential direction over the fairing portion 40. With such a reel seat grip member, not only lightweight and compact hood but also a high degree of freedom in design can be achieved, and the weight can be significantly reduced as compared with the related art.

[0053]

Dimensions, materials, and arrangements of the components described in this specification are not limited to those explicitly described in the embodiments, and the components may be modified to have any dimensions, materials, and arrangements that may

fall within the scope of the present invention. In addition, components not explicitly described in the present specification can also be added to the described embodiment, or some of the components described in each embodiment can also be omitted.

[0054]

It is to be understood that, if any prior art publication is referred to herein, such reference does not constitute an admission that the publication forms a part of the common general knowledge in the art, in Australia or any other country.

[0055]

In the claims which follow and in the preceding description of the invention, except where the context requires otherwise due to express language or necessary implication, the word “comprise” or variations such as “comprises” or “comprising” is used in an inclusive sense, i.e. to specify the presence of the stated features but not to preclude the presence or addition of further features in various embodiments of the invention.

#### Reference Signs List

[0056]

- 1 fishing rod
- 2 rod body
- 3 base rod
- 4 grip
- 5 middle rod
- 6 reel

- 6a reel leg
- 7 tip rod
- 9 reel seat
- 10 fishing line guide
- 12 reel seat main body
- 12a reel leg placing surface
- 13 hood
- 14 first moving hood
- 15 first nut portion
- 20 reel seat grip member
- 21 notch
- 22 second moving hood
- 23 second nut portion
- 24 honeycomb structure
- 25 attachment member
- 26 male screw portion
- 27 female screw portion
- 28 ring-shaped member
- 30 reel seat grip structure
- 40 fairing portion
- 50 rearward portion

## CLAIMS

The claims defining the invention are as follows:

1. A reel seat grip member comprising:  
a fairing portion; and  
a rearward portion connected to the fairing portion,  
wherein the fairing portion is attached at one end of the fairing portion to at least one hood of a pair of hoods provided on a rod body for fixing a reel leg, and  
the rearward portion is attached at one end of the rearward portion to the rod body via an attachment member provided on the rod body, and  
wherein the rearward portion is attached to an area of the rod body between the at least one hood of the pair of hoods, and a rear end of the rod body.
2. The reel seat grip member according to claim 1, wherein the fairing portion is attached to the at least one hood by adhesion, fitting, or mechanical fastening.
3. The reel seat grip member according to claim 1 or 2, wherein the rearward portion is attached to the attachment member by adhesion, fitting, or mechanical fastening.
4. The reel seat grip member according to any one of claims 1 to 3, wherein the fairing portion and the rearward portion are rigidly fixed to the rod body.

5. The reel seat grip member according to any one of claims 1 to 4, wherein when the fairing portion and the rearward portion are rigidly fixed to the rod body, the at least one hood and the attachment member are fixed to the rod body by adhesion, fitting, or mechanical fastening.

6. The reel seat grip member according to any one of claims 1 to 3, wherein the fairing portion and the rearward portion are movably mounted to the rod body.

7. The reel seat grip member according to claim 6, wherein when the fairing portion and the rearward portion are movably mounted to the rod body, the at least one hood and the attachment member are movable with respect to the rod body in an axial direction of the rod body.

8. The reel seat grip member according to claim 7, wherein the at least one hood and the attachment member are movable with respect to the rod body in the axial direction of the rod body such that inner peripheral surfaces of the at least one hood and the attachment member are screwed into an outer peripheral surface of the rod body.

9. The reel seat grip member according to any one of claims 1 to 8, wherein the fairing portion and the rearward portion are integrally formed from carbon fiber reinforced plastic.

10. The reel seat grip member according to any one of claims 1 to 9, wherein one or a plurality of notches are formed in a part of the reel seat grip member.

11. The reel seat grip member according to any one of claims 1 to 10, wherein one or a plurality of honeycomb structures are formed in a part of the reel seat grip member.
  
12. A reel seat grip structure comprising:
  - a reel seat grip member according to any one of claims 1 to 11;
  - a pair of hoods for fixing a reel leg provided on a rod body; and
  - an attachment member for attaching the reel seat grip member to the rod body.
  
13. A fishing rod comprising:
  - a rod body;
  - the reel seat grip member according to any one of claims 1 to 11;
  - a pair of hoods for fixing a reel leg provided on the rod body; and
  - an attachment member for attaching the reel seat grip member to the rod body.

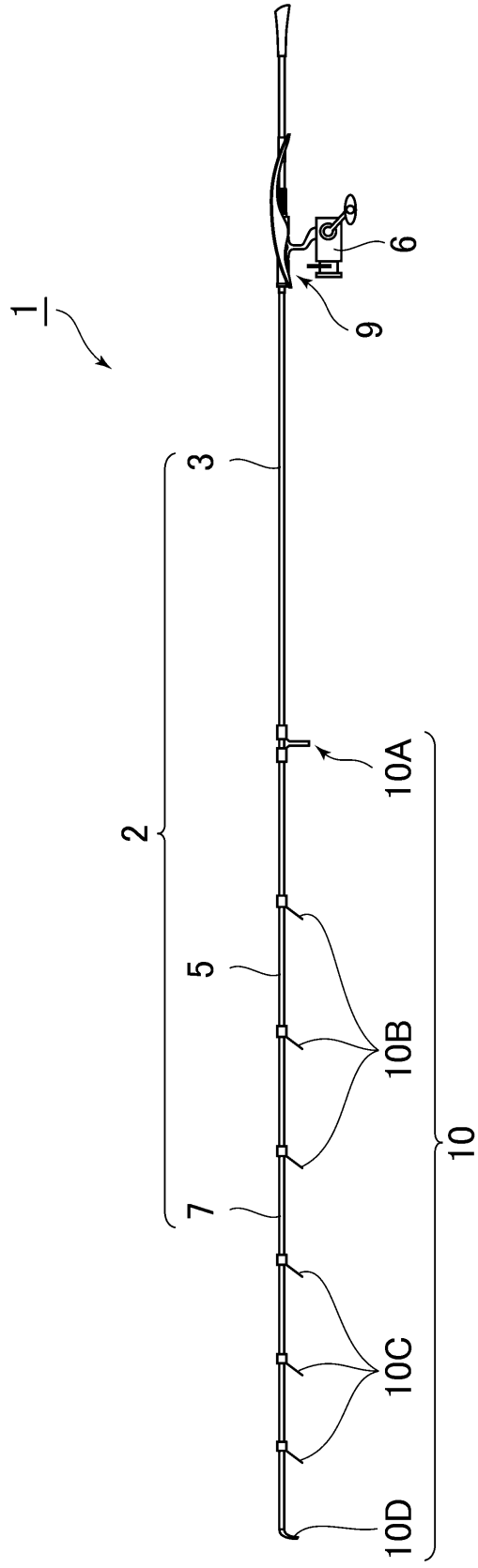

FIG.1

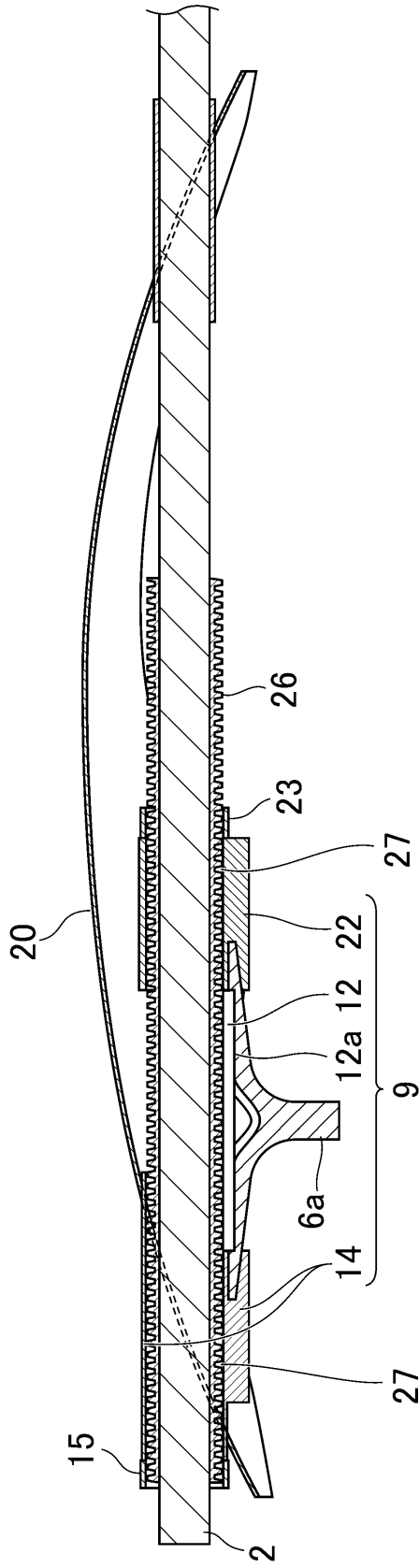

FIG. 2

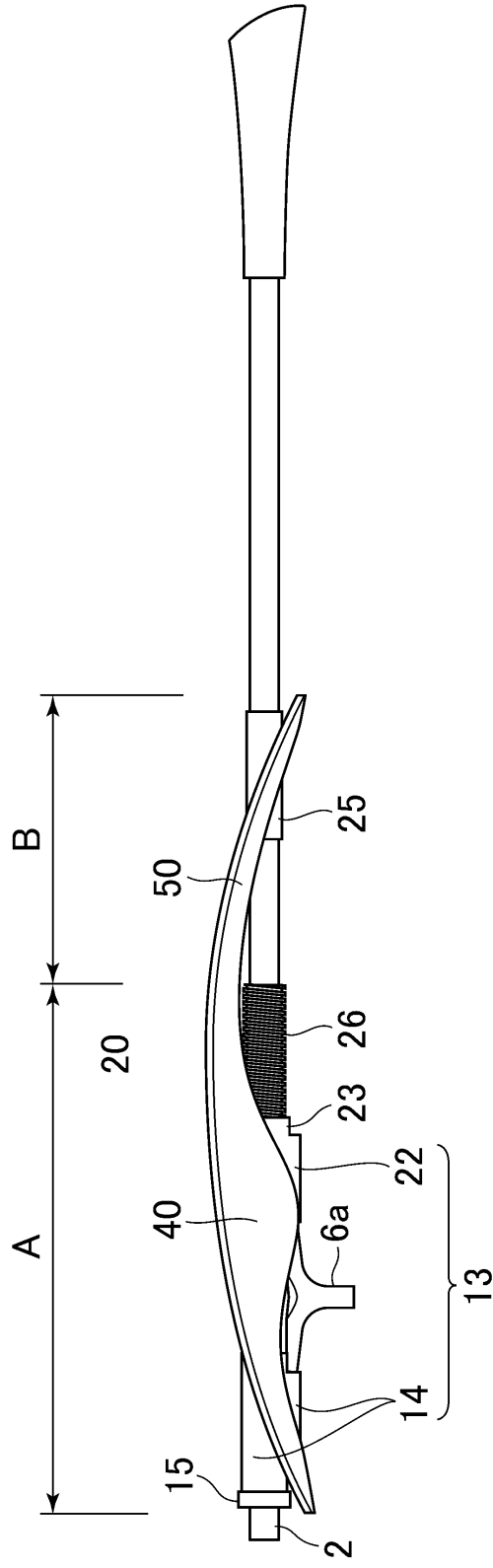

FIG. 3

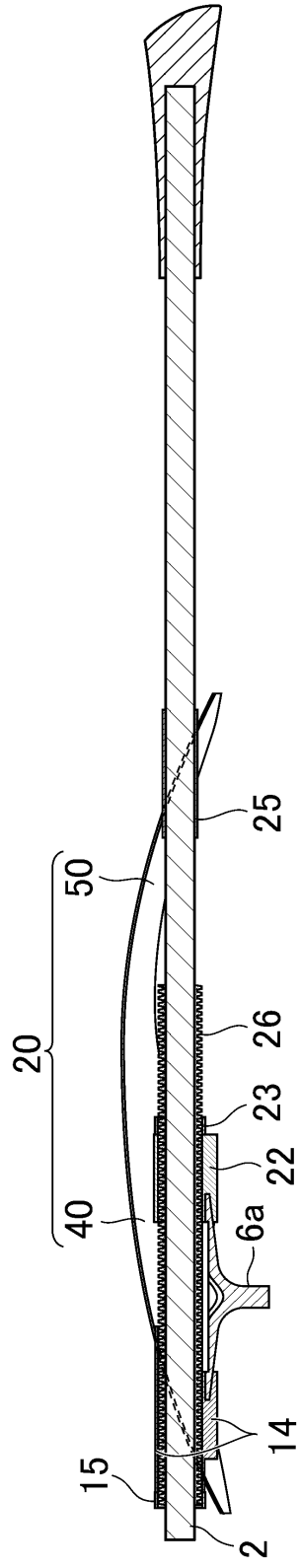

FIG. 4

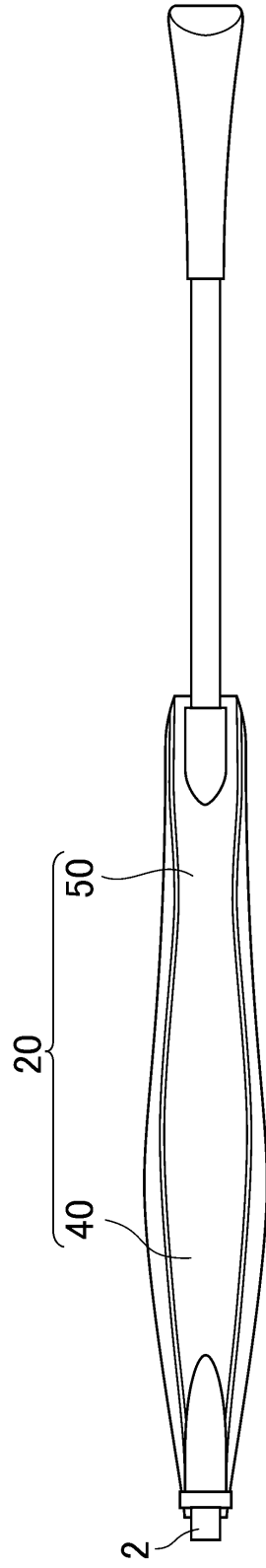

FIG. 5

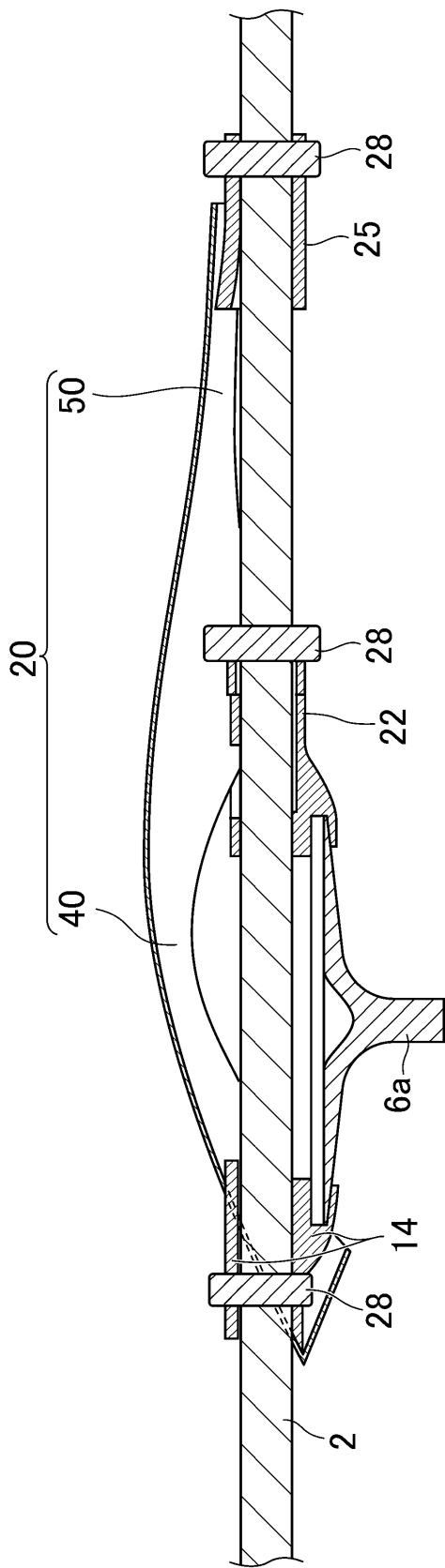

FIG. 6

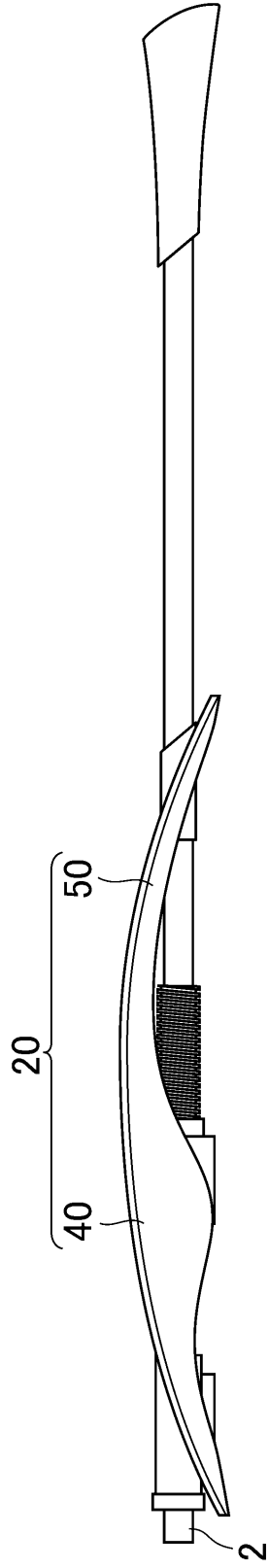

FIG. 7A

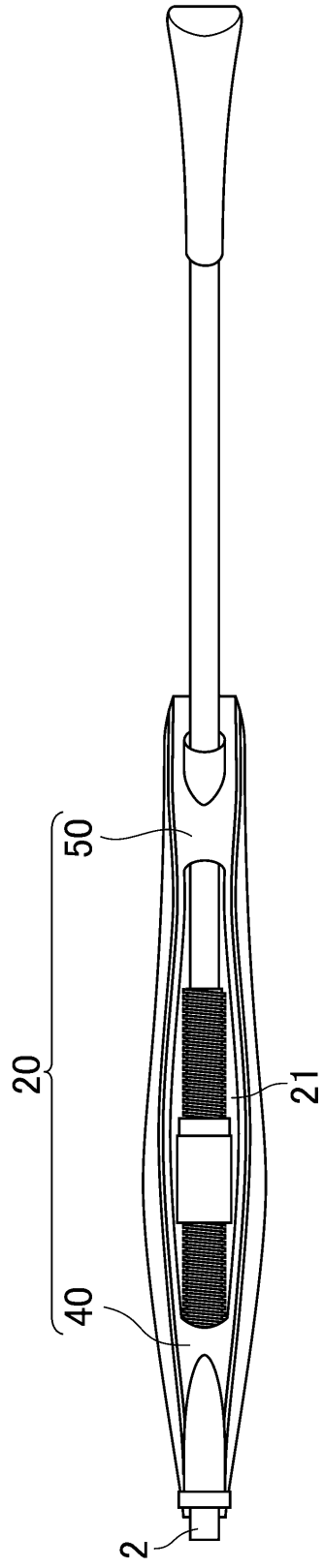

FIG. 7B

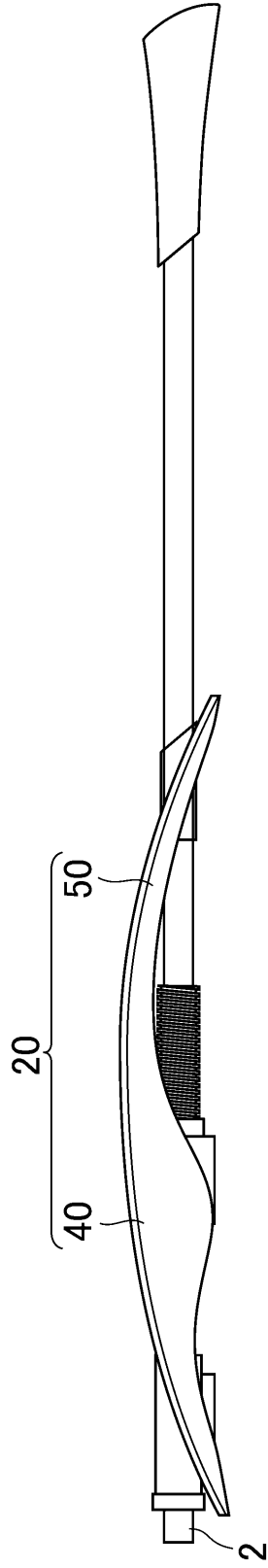

FIG. 8A

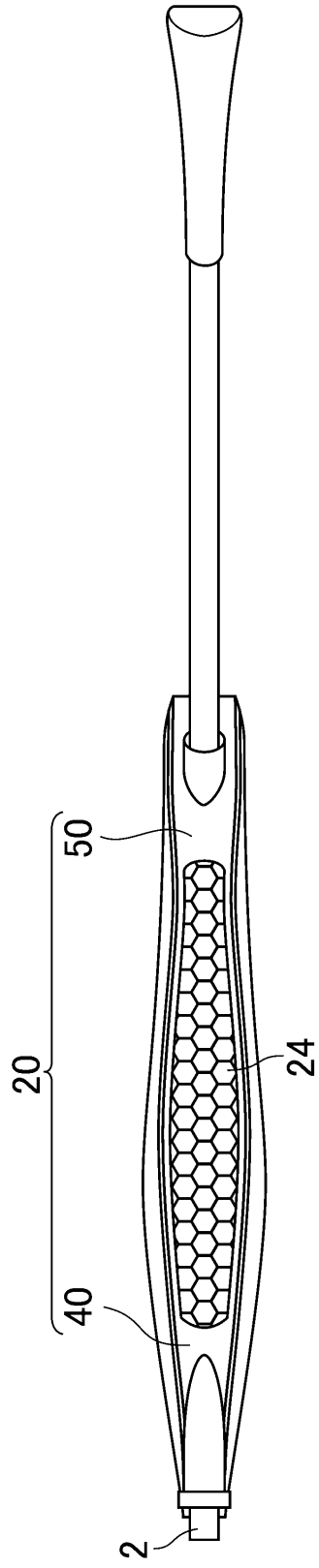

FIG. 8B