

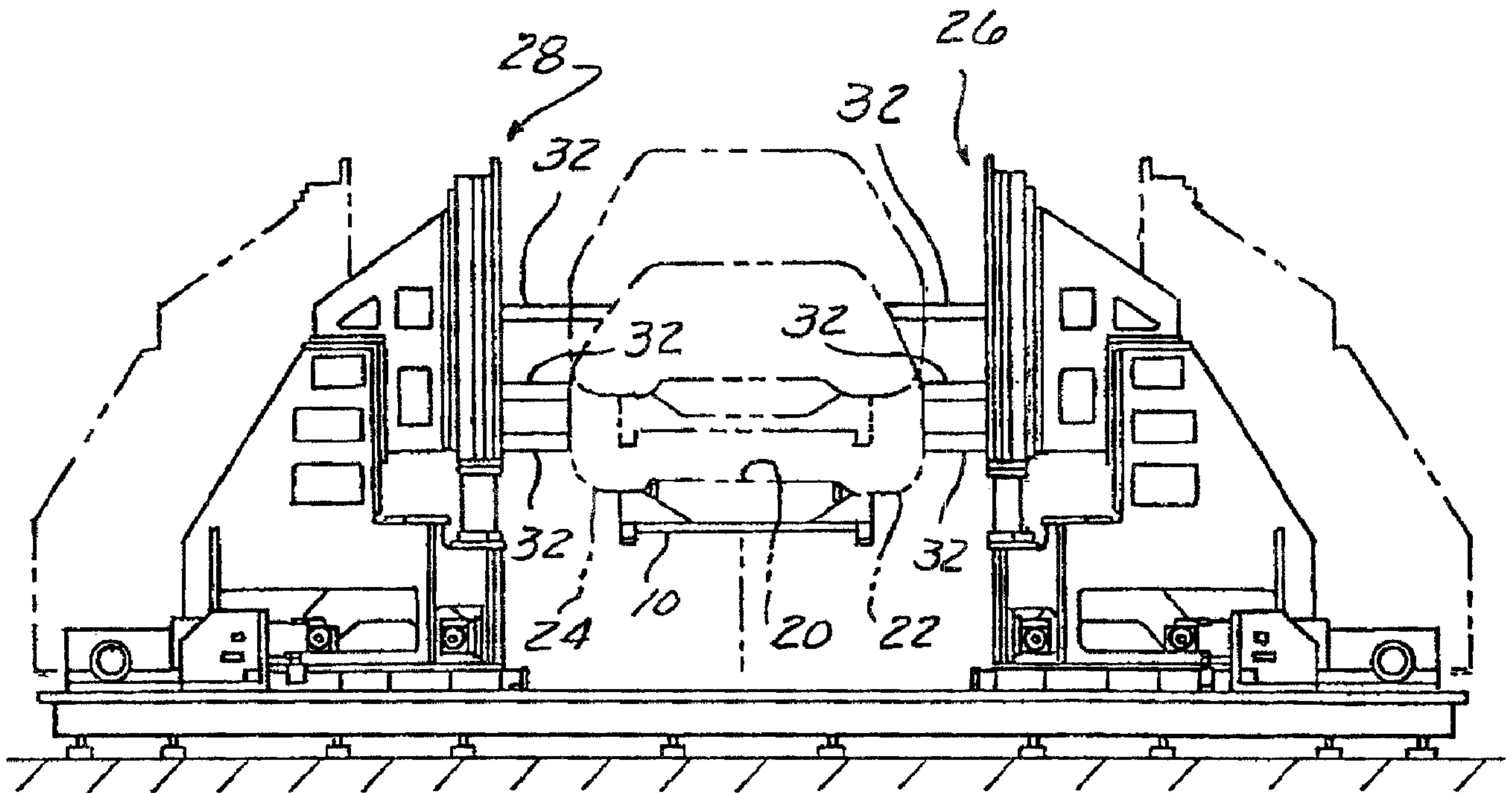

(86) Date de dépôt PCT/PCT Filing Date: 2004/06/30  
 (87) Date publication PCT/PCT Publication Date: 2004/12/30  
 (45) Date de délivrance/Issue Date: 2009/07/28  
 (85) Entrée phase nationale/National Entry: 2004/10/15  
 (86) N° demande PCT/PCT Application No.: US 2004/021427  
 (87) N° publication PCT/PCT Publication No.: 2005/002920  
 (30) Priorité/Priority: 2003/06/30 (US60/483,884)

(51) Cl.Int./Int.Cl. *B62D 65/00* (2006.01),  
*B21J 15/02* (2006.01), *B21J 15/14* (2006.01),  
*B23P 11/00* (2006.01), *B23P 19/10* (2006.01),  
*B62D 65/02* (2006.01)  
 (72) Inventeurs/Inventors:  
 KILIBARDA, VELIBOR, US;  
 DUGAS, MICHAEL R., US  
 (73) Propriétaire/Owner:  
 PROGRESSIVE TOOL & INDUSTRIES, CO., US  
 (74) Agent: SIM & MCBURNEY

(54) Titre : POSTE D'ASSEMBLAGE AVEC RIVETS AUTO-PERFORANTS  
 (54) Title: FRAMING STATION HAVING SELF PIERCING RIVETS



(57) Abrégé/Abstract:

An apparatus and process for assembling individual body components of a body-in-white vehicle with respect to one another to form a unitary vehicle body including a framing workstation for receiving and positionally locating an underbody member of the vehicle, and for receiving and positionally locating at least one upper body member of the vehicle with respect to the underbody member. The framing workstation establishing a predetermined geometry of the individual body components, while forming the unitary vehicle body. At least one self-piercing rivet tool for securing the at least one upper body member of the vehicle to the underbody member of the vehicle to form and maintain the predetermined geometry of the unitary vehicle body with self-piercing rivets.

ABSTRACT OF THE DISCLOSURE

[0016] An apparatus and process for assembling individual body components of a body-in-white vehicle with respect to one another to form a unitary vehicle body including a framing workstation for receiving and positionally locating an underbody member of the vehicle, and for receiving and positionally locating at least one upper body member of the vehicle with respect to the underbody member. The framing workstation establishing a predetermined geometry of the individual body components, while forming the unitary vehicle body. At least one self-piercing rivet tool for securing the at least one upper body member of the vehicle to the underbody member of the vehicle to form and maintain the predetermined geometry of the unitary vehicle body with self-piercing rivets.

**FRAMING STATION HAVING SELF PIERCING RIVETS****FIELD OF THE INVENTION**

**[0001]** The present invention relates to an automotive framing workstation on an assembly line for framing an automotive body having a plurality of panels with respect to one another using self piercing rivets.

**BACKGROUND OF THE INVENTION**

**[0002]** Self piercing rivets and associated tools for fastening two or more pieces of material with respect to one another are generally known. See U.S. Patent No. 5,752,305; U.S. Patent No. 5,779,127; U.S. Patent No. 5,813,114; U.S. Patent No. 5,884,386; U.S. Patent No. 6,089,437; and U.S. Patent No. 6,116,835. Self piercing rivets have typically been used in non critical connections attaching two or more pieces of material with respect to one another.

**SUMMARY OF THE INVENTION**

**[0003]** It would be desirable in the present invention to assembly an automotive body at a framing station using self piercing rivets rather than spot welding the major panels with respect to one another. It is believed that self piercing rivets can provide a connection between the components of the automotive vehicle uni-body frame substantially equivalent to spot welding attachment of the frame components to one another as is commonly practiced in the industry today. Further, increased flexibility, and reduced cost for the production of automotive bodies through the framing station according to the present invention.

**[0004]** Accordingly, in one aspect of the present invention there is provided an apparatus for assembling individual contoured body components of a body-in-white vehicle with respect to one another to form a unitary vehicle body comprising:

a framing workstation for receiving and positionally locating an underbody contoured member of the vehicle, and for receiving and positionally locating at least one contoured upper body member of the vehicle with respect to the underbody member, the framing workstation for establishing a predetermined geometry of the individual contoured body components while forming the unitary vehicle body; and

at least one self-piercing rivet tool for securing the at least one contoured upper body member of the vehicle to the underbody contoured member of the vehicle to form and maintain the predetermined geometry of the unitary vehicle body with self-piercing rivets.

**[0004a]** According to another aspect of the present invention there is provided a process for assembling individual contoured body components of a body-in-white vehicle with respect to one another to form a unitary vehicle body comprising the steps of:

receiving and positionally locating an underbody contoured member of the vehicle at a framing workstation;

receiving and positionally locating at least one contoured upper body member of the vehicle with respect to the underbody member at the framing workstation;

establishing a predetermined geometry of the individual contoured body components while forming the unitary vehicle body at the framing workstation; and

securing the at least one contoured upper body member of the vehicle to the underbody contoured member of the vehicle with at least one self-piercing rivet tool to form and maintain the predetermined geometry of the unitary vehicle body with self-piercing rivets.

**[0005]** Other applications of the present invention will become apparent to those skilled in the art when the following description of the best mode contemplated for practicing the invention is read in conjunction with the accompanying drawings.

BRIEF DESCRIPTION OF THE DRAWINGS

[0006] The description herein makes reference to the accompanying drawings wherein like reference numerals refer to like parts throughout the several views, and wherein:

[0007] Figure 1 is a simplified schematic view of an automotive assembly line according to the present invention having four workstations;

[0008] Figure 2 is a simplified schematic end elevational view of one of the workstations;

[0009] Figure 3 is a simplified schematic view of an automotive body assembled with self piercing rivets according to the present invention; and

[0010] Figure 4 is a simplified schematic view of a self piercing rivet tool attached to a robotic arm.

DESCRIPTION OF THE PREFERRED EMBODIMENT

[0011] Referring now to Figure 1, an automotive assembly line can include an underbody delivery system. The automotive assembly line 10 passes through four schematically illustrated workstations 12, 14, 16, 18. According to the present invention, each of the four workstations can be configured for a different automotive body style enabling four different body styles to be handled by the automotive assembly line 10. Alternatively, a single body style can pass through one or more of the workstations for receiving different assembly processing at the sequential workstations. The underbody 20 of the motor vehicle can be delivered to the appropriate workstation 12, 14, 16, or 18, by any appropriate transport system, such as by a pallet delivery system, or overhead delivery system. Right and left side body assemblies 22, 24 can be delivered to the workstation by any appropriate delivery system, such as an overhead conveyor system to be positioned with respect to the underbody 20. The body side panels 22, 24 can either be handled by robotic manipulators for accurate positioning with respect to the underbody 20, or can be clamped to geometry fixtures 26, 28 for movement and positioning relative to the underbody 20 at the workstation. Referring now to Figures 1 and 2, the transversely movable frame members 26, 28 can support either or both of the side body panels 22, 24, and/or can support one or more self piercing rivet tools for engagement with the

side body panels 22, 24. The side body panels 22, 24 can be manually loaded into a geometry fixture associated with the movable frame members 26, 28 and/or can be loaded with automated equipment, by way of example and not limitation, by robots having side panel manipulators for holding the side panel for loading into the geometry fixture associated with the movable frame members 22, 24. Alternatively, a robot can position at least one upper body member with respect to the underbody, or at least one upper body member can be loaded into a geometry fixture associated with the movable frame members 22, 24, and/or a second upper body member, by way of example and not limitation, such as a roof header can be held in position by a robot during fastening with self-piercing rivets, or any combination of the two. Since self riveting tooling is appreciable smaller than welding guns, additional tooling can be located on each frame to increase the total number of attachment points per workstation and to reduce cycle time since additional time for movement of the robotically manipulated weld gun from point to point is no longer required at the self piercing rivet assembly workstation. Even if a robotically manipulated self piercing rivet tool is required, the total number of attachment points to be serviced by the robotically manipulated self piercing riveting tool is dramatically reduced in order to decrease cycle time at the workstation.

[0012] Referring now to Figure 3, a simplified schematic side elevational view of a side body panel is illustrated. The side body panel 24 is a mirror image of the side panel body 22 at various locations for self piercing rivet assembly are shown with marks labeled 30. It is believed that 10 to 15 self piercing rivet connections can be made between the corresponding side panel 22, 24 and the underbody 20 at each workstation. A substantial portion of the self piercing riveting connections can be made simultaneously from tooling connected to the movable frames 26, 28.

[0013] Referring now to Figure 4, if a robotically manipulated self piercing riveting tool 32 is required, multiple self piercing rivet connections can be made between the corresponding side body panel 22, 24 and the underbody 20 with the same tool 32 being manipulated by the robotic arm 34. Self piercing riveting tools can also be used to connect the header or roof assembly 36 to the side body panels 22, 24. The elimination of robotically manipulated weld guns greatly simplifies the

configuration of the movable frame system, since the self piercing riveting tooling is appreciably smaller than the weld guns, requires less clearance, and permits mounting of a substantial number of self piercing riveting tools directly to the frame assembly.

[0014] According to the present invention, the underbody, side panels, and/or roof assembly can be toy tabbed together prior to entering the framing workstation. The toy tab configuration can be accomplished either manually or robotically. Alternatively, the side panel members can be robotically loaded directly into the workstation gate equipped with self piercing riveting tools to assemble the side panels to the underbody and to assemble the roof to the side panels. In this configuration the robots are used for material handling only in order to simplify the workstation configuration. It is believed that an automotive assembly line according to the present invention can operate 200 jobs per hour with 10 to 15 self piercing rivet guns per workstation frame. Each self piercing rivet tool can be supplied with a strip of self piercing rivets having 5000 to 6000 fasteners. Approximately 1000 to 1200 rivets would be performed per tool per day requiring reloading of the rivet tools with new strips of self piercing rivets on a weekly basis.

[0015] While the invention has been described in connection with what is presently considered to be the most practical and preferred embodiment, it is to be understood that the invention is not to be limited to the disclosed embodiments but, on the contrary, is intended to cover various modifications and equivalent arrangements included within the spirit and scope of the appended claims, which scope is to be accorded the broadest interpretation so as to encompass all such modifications and equivalent structures as is permitted under the law.

**What is claimed is:**

1. An apparatus for assembling individual contoured body components of a body-in-white vehicle with respect to one another to form a unitary vehicle body comprising:

a framing workstation for receiving and positionally locating an underbody contoured member of the vehicle, and for receiving and positionally locating at least one contoured upper body member of the vehicle with respect to the underbody member, the framing workstation for establishing a predetermined geometry of the individual contoured body components while forming the unitary vehicle body; and

at least one self-piercing rivet tool for securing the at least one contoured upper body member of the vehicle to the underbody contoured member of the vehicle to form and maintain the predetermined geometry of the unitary vehicle body with self-piercing rivets.

2. The apparatus of claim 1, wherein the at least one upper body member of the vehicle further comprises:

a left-hand bodyside panel and a right-hand bodyside panel of the vehicle to be received and positionally located with respect to the underbody member.

3. The apparatus of claim 2, wherein the at least one upper body member further comprises:

a header member extending between the left-hand bodyside panel and the right-hand bodyside panel of the vehicle spaced vertically from the underbody member, the header member to be received and positionally located with respect to the left-hand bodyside panel and the right-hand bodyside panel of the vehicle at the framing station, and while being connected with respect to one another with self-piercing rivets.

4. The apparatus of claim 1, wherein the underbody member further comprises a floor pan of the vehicle to be received and positionally located with respect to the upper body member of the vehicle.

5. The apparatus of claim 1 further comprising:

a robot located at the framing station for receiving and positionally locating the at least one upper body member with respect to the underbody member of the vehicle.

6. The apparatus of claim 1 further comprising:  
at least one geometry fixture located at the framing station for receiving and positionally locating the at least one upper body member with respect to the underbody member of the vehicle.
7. The apparatus of claim 5 further comprising:  
the at least one geometry fixture defined by at least one frame transversely moveable between a part-loading position, where the at least one upper body member of the vehicle can be loaded into the geometry fixture, and a vehicle-framing position, where the at least one upper body member can be held in the predetermined geometry with respect to the underbody member to form the unitary vehicle body.
8. The apparatus of claim 7 further comprising:  
the at least one self-piercing rivet tool connected to the at least one frame for securing the at least one upper body member of the vehicle to the underbody member of the vehicle to form and maintain the predetermined geometry of the unitary vehicle body with self-piercing rivets.
9. The apparatus of claim 1 further comprising:  
a robot located at the framing workstation having a self-piercing rivet tool for securing the at least one upper body member of the vehicle to the underbody member of the vehicle to form and maintain the predetermined geometry of the unitary vehicle body with self-piercing rivets.
10. The apparatus of claim 1 further comprising:  
a robot located at the framing workstation having a self-piercing rivet tool for securing the at least one upper body member of the vehicle to the underbody member of the vehicle to form and maintain the predetermined geometry of the unitary vehicle body with self-piercing rivets; and  
at least one self-piercing rivet tool connected to at least one frame for securing the at least one upper body member of the vehicle to the underbody member of the vehicle to form and maintain the predetermined geometry of the unitary vehicle body with self-piercing rivets.
11. The apparatus of claim 1 further comprising:  
the underbody member and the at least one upper body member toy tabbed together prior to entering the framing workstation.

12. The apparatus of claim 1 further comprising:  
a plurality of framing workstations, each framing workstation for receiving and positionally locating the underbody member of the vehicle for a different automotive body style, and for receiving and positionally locating the at least one upper body member of the vehicle with respect to the underbody member for the different automotive body style, the framing workstation for establishing the predetermined geometry of the individual body components while forming the unitary vehicle body of the particular automotive body style to be assembled.
13. The apparatus of claim 1 further comprising:  
a plurality of framing workstations, each framing workstation for sequentially receiving and positionally locating the underbody member of the vehicle, and for receiving and positionally locating at least one upper body member of the vehicle with respect to the underbody member, the framing workstation for establishing a predetermined geometry of the individual body components while sequentially performing assembling processes on the unitary vehicle body.
14. A process for assembling individual contoured body components of a body-in-white vehicle with respect to one another to form a unitary vehicle body comprising the steps of:  
receiving and positionally locating an underbody contoured member of the vehicle at a framing workstation;  
receiving and positionally locating at least one contoured upper body member of the vehicle with respect to the underbody member at the framing workstation;  
establishing a predetermined geometry of the individual contoured body components while forming the unitary vehicle body at the framing workstation; and  
securing the at least one contoured upper body member of the vehicle to the underbody contoured member of the vehicle with at least one self-piercing rivet tool to form and maintain the predetermined geometry of the unitary vehicle body with self-piercing rivets.
15. The process of claim 14, wherein the receiving and positionally locating at least one upper body member of the vehicle step further comprises the step of:  
receiving and positionally locating a left-hand bodyside panel and a right-hand bodyside panel of the vehicle with respect to the underbody member.

16. The process of claim 15 wherein the receiving and positionally locating at least one upper body member step further comprises the step of:

receiving and positionally locating a header member extending between the left-hand bodyside panel and the right-hand bodyside panel of the vehicle, and spaced vertically from the underbody member; and

connecting the header member with respect to the left-hand bodyside panel and the right-hand bodyside panel with self-piercing rivets.

17. The process of claim 14, wherein the receiving and positionally locating the underbody member further comprises the step of:

receiving and positionally locating a floor pan of the vehicle with respect to the upper body member of the vehicle.

18. The process of claim 14, wherein the receiving and positionally locating at least one upper body member step further comprises the step of:

receiving and positionally locating the at least one upper body member with respect to the underbody member of the vehicle with a robot located at the framing station.

19. The process of claim 14, wherein the receiving and positionally locating at least one upper body member further comprises the step of:

receiving and positionally locating the at least one upper body member with respect to the underbody member of the vehicle with at least one geometry fixture located at the framing station.

20. The process of claim 19 further comprising the steps of:

transversely moving the at least one geometry fixture defined by at least one frame between a part-loading position, where the at least one upper body member of the vehicle can be loaded into the geometry fixture, and a vehicle-framing position, where the at least one upper body member can be held in the predetermined geometry with respect to the underbody member to form the unitary vehicle body.

21. The process of claim 20 further comprising the steps of:

connecting at least one self-piercing rivet tool to the at least one frame;  
and

securing the at least one upper body member of the vehicle to the underbody member of the vehicle to form and maintain the predetermined geometry of the unitary vehicle body with self-piercing rivets.

22. The process of claim 14 further comprising the steps of:  
locating a robot at the framing workstation having a self-piercing rivet tool; and

securing the at least one upper body member of the vehicle to the underbody member of the vehicle to form and maintain the predetermined geometry of the unitary vehicle body with self-piercing rivets.

23. The process of claim 14 further comprising the steps of:  
locating a robot at the framing workstation having a self-piercing rivet tool;

connecting at least one self-piercing rivet tool to at least one reciprocal geometry fixture frame; and

securing the at least one upper body member of the vehicle to the underbody member of the vehicle with the self-piercing rivet tool carried by the robot and with the at least one self-piercing rivet tool connected to the geometry fixture frame to form and maintain the predetermined geometry of the unitary vehicle body with self-piercing rivets.

24. The process of claim 14 further comprising the step of:  
toy tabbing the underbody member and the at least one upper body member together prior to delivery to the framing workstation.

25. The process of claim 14 further comprising the step of:  
processing a plurality of different automotive body styles through a plurality of framing workstations, each framing workstation for receiving and positionally locating the underbody member of the vehicle for a different automotive body style, and for receiving and positionally locating the at least one upper body member of the vehicle with respect to the underbody member for the particular corresponding different automotive body style, the framing workstation for establishing the predetermined geometry of the individual body components while forming the unitary vehicle body of the particular automotive body style to be assembled.

26. The process of claim 14 further comprising the step of:  
processing the at least one upper body member and underbody member through a plurality of framing workstations, each framing workstation for sequentially receiving and positionally locating the underbody member of the vehicle, and for receiving and positionally locating the at least one upper body member of the vehicle with respect to the underbody member, each framing workstation for establishing a predetermined geometry of the individual body components while sequentially performing assembling processes on the unitary vehicle body.



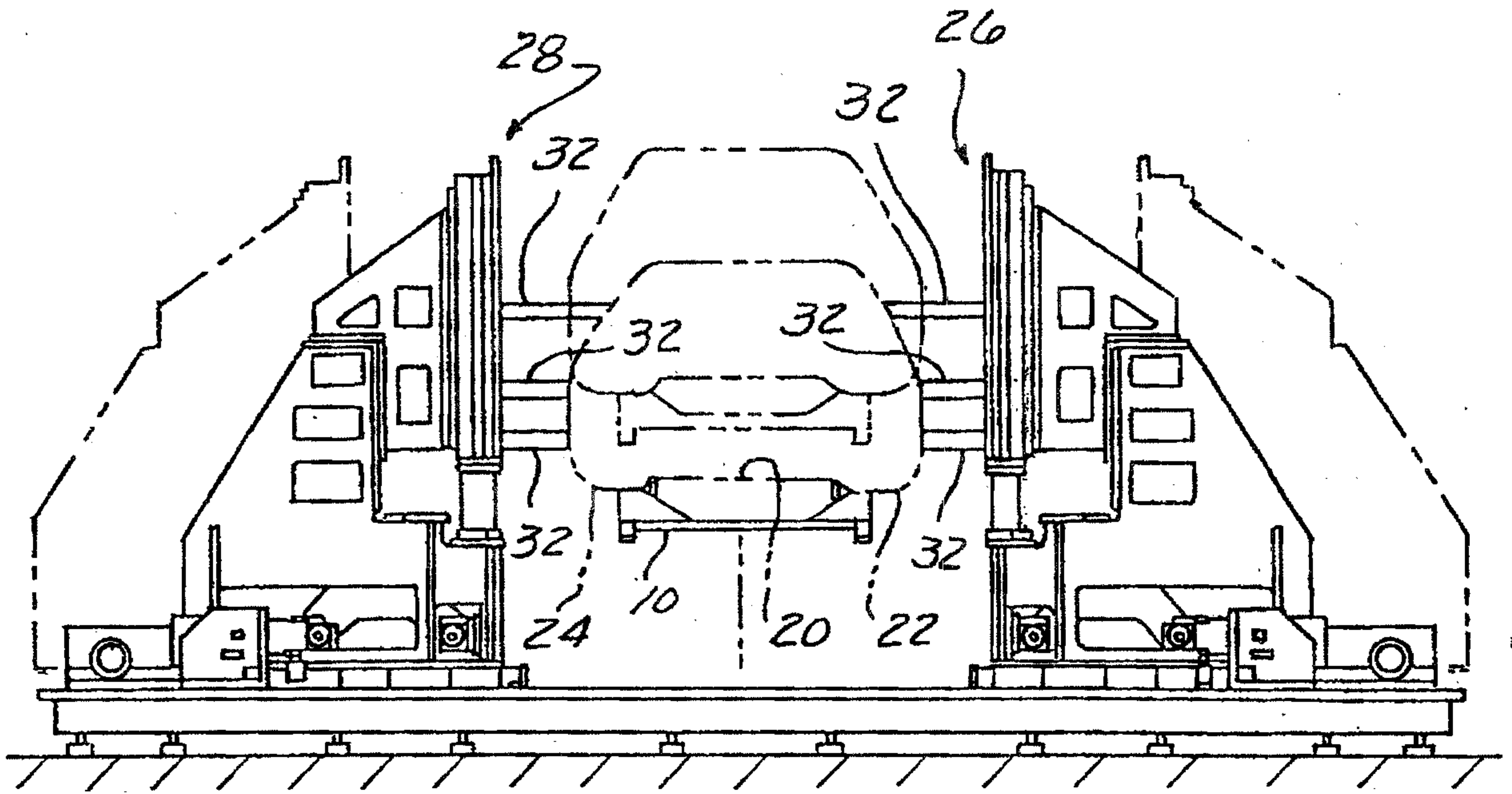

FIG. 2

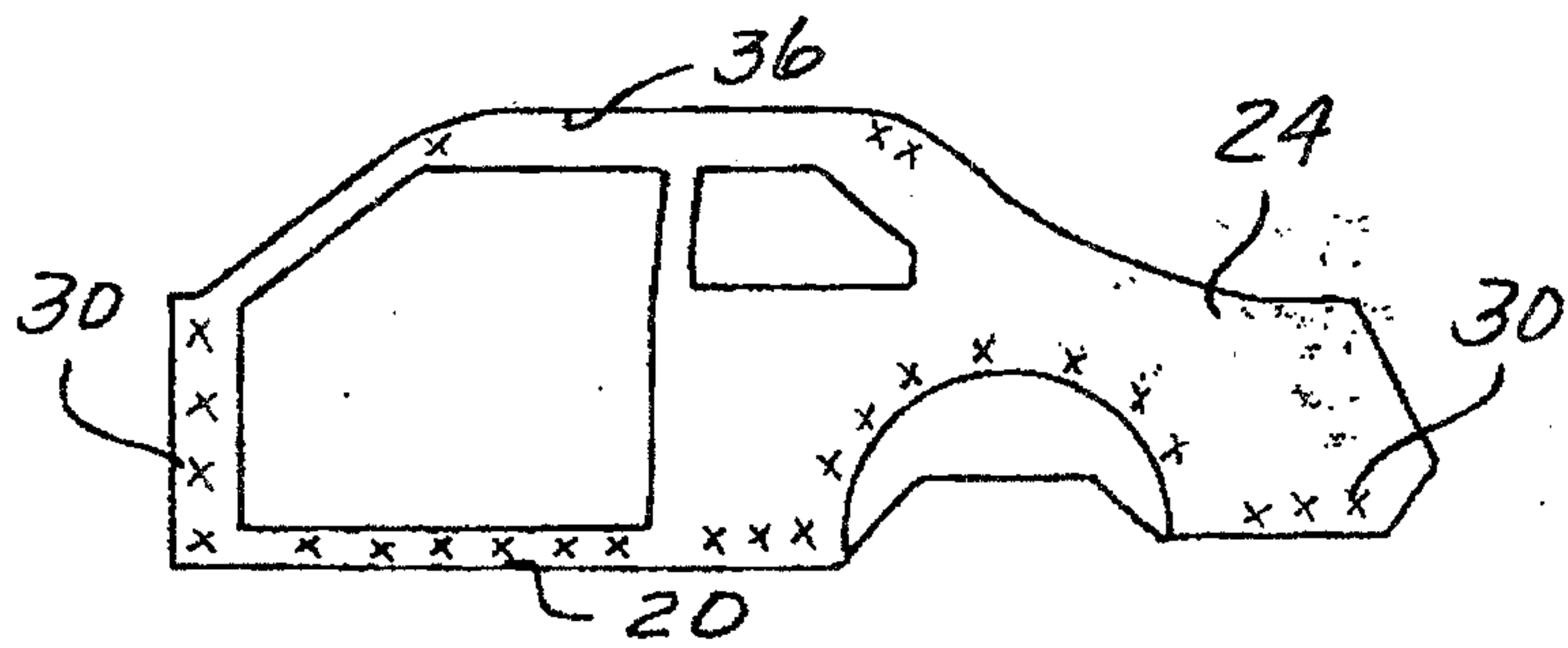

FIG. 3

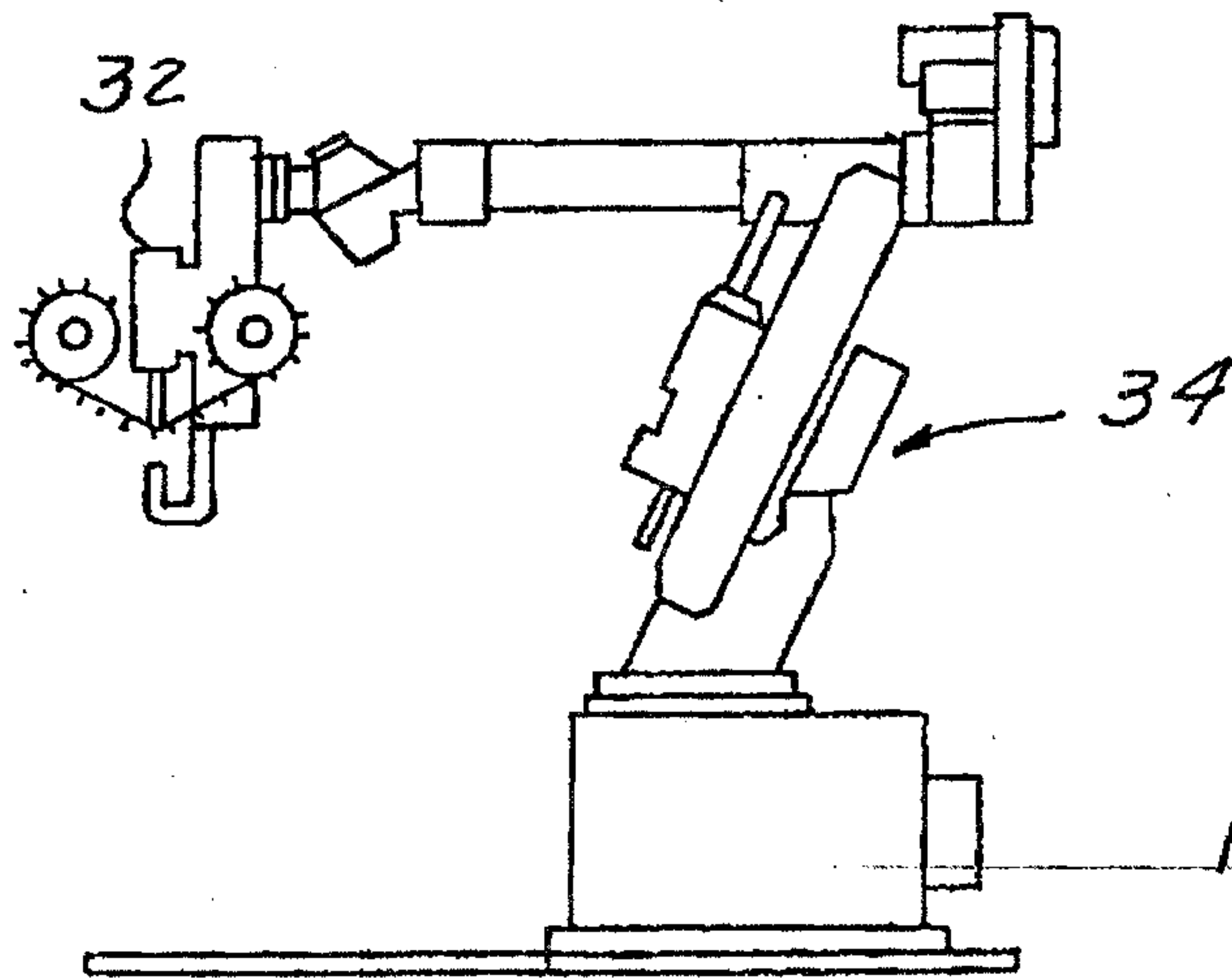

FIG. 4

