

H. Jackson,

Padlock

N^o 46,241.

Patented Feb. 7, 1865.

Fig. 2.

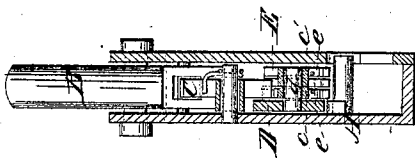

Fig. 3.



Fig. 1.

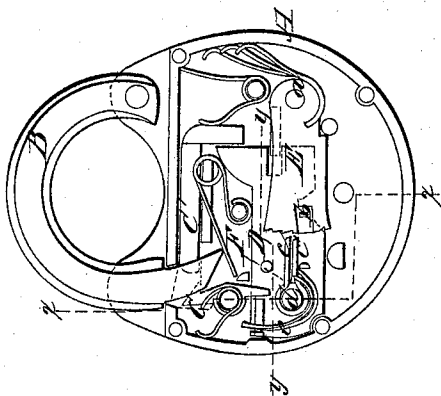
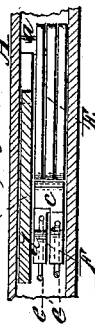

Fig. 4.



Witnesses:
R. D. Jackson
H. M. Livingston

Inventor:

Henry Jackson

UNITED STATES PATENT OFFICE.

HENRY JACKSON, OF BROOKLYN, NEW YORK.

IMPROVEMENT IN LOCKS.

Specification forming part of Letters Patent No. 46,241, dated February 7, 1865.

To all whom it may concern:

Be it known that I, HENRY JACKSON, of Brooklyn, in the county of Kings and State of New York, have invented a new and Improved Lock; and I do hereby declare that the following is a full, clear, and exact description thereof, which will enable others skilled in the art to make and use the same, reference being had to the accompanying drawings, forming part of this specification, in which—

Figure 1 is an internal view of a padlock having my improvement applied to it; Fig. 2, a section of the same taken in the line *x x*, Fig. 1; Fig. 3, a detached side view of the tumblers and stub pertaining to the same; Fig. 4, a section of the same taken in the line *y y*, Fig. 1.

Similar letters of reference indicate like parts.

The object of this invention is to prevent a lock being picked or opened illegitimately by obtaining a pressure of the stub on the tumblers—a means usually resorted to by burglars in order to ascertain the position the tumblers must be brought to in order to admit of the bolt being liberated.

My invention consists in constructing the stub of a plurality of movable plates, arranged in such a manner that when they are pressed against the tumblers and the latter actuated the several plates will catch into the edges of the tumblers and be raised or moved by them, thereby preventing a knowledge of the slots in the tumblers being obtained by a pressure of the stub against them.

The following description refers to my improvement applied to a padlock, but it is applicable to all tumbler-locks.

A represents the case of the padlock, and B the bow or shackle. These parts may be constructed in the usual manner, and therefore do not require a minute description.

C C' represent two jaws, C being a pivoted one and C' a sliding one. These jaws engage with the end of the bow or shackle B, which passes into the case A, and secures it in a locked state, said jaws being forced apart in order to liberate the bow or shackle by a slide, D, which is operated by a key.

E represents a series of tumblers, which are placed on one and the same pin, *a*, and allowed to work freely thereon. These tum-

blers are by the side of the slide D, and they are notched or serrated at their free or disengaged edges, and have each a slot, *b*, made longitudinally in them, said slots, when the tumblers are not operated upon by the key, being out of line with each other, so that the tumbler will require to be moved different distances in order to bring the several slots in line with each other.

F represents a stub, attached to the slide D. This stub is represented in the drawings as being composed of two plates *c c'*, but more may be used, if desired. These plates are both fitted on a pin, *d*, on the slide so as to turn freely thereon, and so arranged that the outer part of the plate *c* will be directly over the plate *c'*. The upper plate, *c*, is a trifle longer than the lower one, *c'*, and when not operated by the tumblers are kept in contact by springs *e*.

The tumblers E and stub F are designed to prevent the slide D being illegitimately operated, and in order to move said slide the tumblers E must first be adjusted so that their slots *p* will be brought in line with each other to receive the stub F. This is effected by a proper key, which, as it is turned, first actuates the tumblers as specified and then moves the slide.

In case a person attempts to open the lock in an illegitimate manner the slide D is moved so as to bring the stub F in contact with the edges of the tumblers. The latter are then turned or moved with a view of ascertaining by the pressure of the stub against them the position of the slots *p*. This may be done with the ordinary fixed or rigid stub; but my improvement effectually prevents such an operation being successfully performed, for the longer upper plate, *c*, which will first come in contact with the tumblers, will catch into the serrated edges thereof, and as the tumblers are moved, one or any number thereof will be shoved upward, as shown in Fig. 3, and when the other plate, *c'*, comes in contact with the tumblers the same result takes place. Thus by this simple movement of the plates the operator will be baffled in ascertaining the position of the slots *b* of the tumblers. As soon as the slide D is allowed to pass back or return to its original position the springs *e* bring the plates *c c'* again in contact.

The stub F may be composed of any number of plates, as previously stated.

This invention is applicable to any tumbler-lock, and it will prove to be a valuable safe-guard against the picking or illegitimate opening of the same.

I claim as new and desire to secure by Letters Patent—

The stub F, constructed, as described, of a

plurality of movable plates *c c*, of unequal length or projection, employed in combination with the tumblers E, in the manner and for the purpose specified.

HENRY JACKSON.

Witnesses:

M. M. LIVINGSTON,

R. D. JACKSON.