

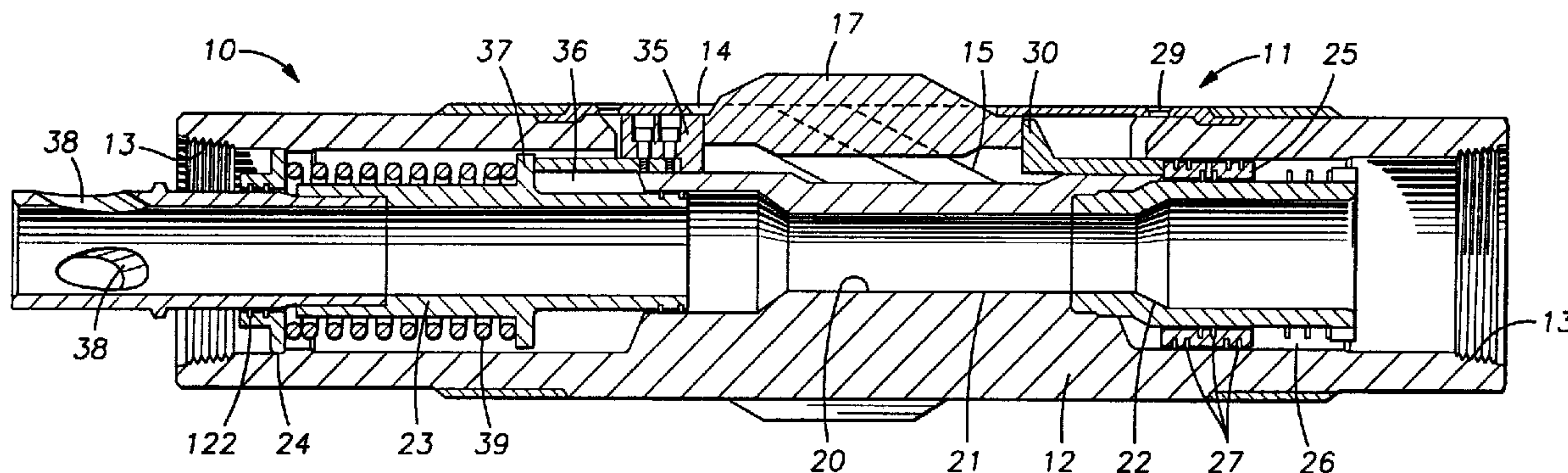

(22) Date de dépôt/Filing Date: 1993/10/21
 (41) Mise à la disp. pub./Open to Public Insp.: 1994/04/24
 (45) Date de délivrance/Issue Date: 2004/12/14
 (30) Priorité/Priority: 1992/10/23 (965,347) US

(51) Cl.Int.⁵/Int.Cl.⁵ E21B 17/10, E21B 7/06
 (72) Inventeurs/Inventors:
 DEWEY, CHARLES H., US;
 UNDERWOOD, LANCE D., US;
 JOHNSON, HAROLD D., US
 (73) Propriétaire/Owner:
 HALLIBURTON COMPANY, US
 (74) Agent: OGILVY RENAULT

(54) Titre : STABILISATEUR REGLABLE
 (54) Title: ADJUSTABLE STABILIZER



(57) Abrégé/Abstract:

A downhole adjustable blade stabilizer is disclosed for varying the position of stabilizer blades to provide an increased ability to control the direction of drilling. The adjustable blade stabilizer includes a plurality of blades mounted in an angled track to permit axial and radial movement of the blades. The blades are driven by a piston in response to a pressure differential created by a sufficient flow of drilling mud through the stabilizer. The stabilizer blades are retracted by a spring when the pressure differential is eliminated. A positioning piston limits blade extension to a desired position. The positioning piston moves in response to a command signal, and remains in place until a new command signal is received. By maintaining the positioning piston in a locked position, the position of the blades can be reset to the prior position after the loss of pressure differential. A measuring means is provided in association with the positioning piston to enable precise measurement of blade position.

2108916

ABSTRACT

A downhole adjustable blade stabilizer is disclosed for varying the position of stabilizer blades to provide an increased ability to control the direction of drilling. The adjustable blade stabilizer includes a plurality of blades mounted in an angled track to permit axial and radial movement of the blades. The blades are driven by a piston in response to a pressure differential created by a sufficient flow of drilling mud through the stabilizer. The stabilizer blades are retracted by a spring when the pressure differential is eliminated. A positioning piston limits blade extension to a desired position. The positioning piston moves in response to a command signal, and remains in place until a new command signal is received. By maintaining the positioning piston in a locked position, the position of the blades can be reset to the prior position after the loss of pressure differential. A measuring means is provided in association with the positioning piston to enable precise measurement of blade position.

ADJUSTABLE STABILIZERBACKGROUND OF THE INVENTIONI. FIELD OF THE INVENTION

The present invention relates generally to a steerable system for controlling borehole deviation with respect to the vertical axis by varying the angle of such deviation without removing (tripping) the system from the borehole, and more particularly to a directional drilling apparatus that is remotely adjustable or variable during operation for affecting deviation control.

II. DESCRIPTION OF THE PRIOR ART

The technology developed with respect to drilling boreholes in the earth has long encompassed the use of various techniques and tools to control the deviation of boreholes during the drilling operation. One such system is shown in U.S. Patent Number Re. 33,751, and is commonly referred to as a steerable system. By definition, a steerable system is one that controls borehole deviation without being required to be withdrawn from the borehole during the drilling operation.

The typical steerable system today comprises a downhole motor having a bent housing, a fixed diameter near bit stabilizer on the lower end of the motor housing, a second fixed diameter stabilizer above the motor housing and an MWD (measurement-while-drilling) system above that. A lead collar of about three to ten feet is sometimes run between the motor and the second stabilizer. Such a system is typically capable of building, dropping or turning about three to eight degrees per 100 feet when sliding, i.e. just the motor output shaft is rotating the drill bit while the drill string remains rotationally stationary. When rotating, i.e. both the motor and the drill string are rotating to drive the bit, the goal is usually for the system to simply hold angle (zero

build rate), but variations in hole conditions, operating parameters, wear on the assembly, etc. usually cause a slight build or drop. This variation from the planned path may be as much as \pm one degree per 100 feet. When this occurs, two options are available. The first option is to make periodic corrections by sliding the system part of the time. The second option is to trip the assembly and change the lead collar length or, less frequently, the diameter of the second stabilizer to fine tune the rotating mode build rate.

One potential problem with the first option is that when sliding, sharp angle changes referred to as doglegs and ledges may be produced, which increase torque and drag on the drill string, thereby reducing drilling efficiencies and capabilities. Moreover, the rate of penetration for the system is lower during the sliding mode. The problem with the second option is the costly time it takes to trip. In addition, the conditions which prevented the assembly from holding angle may change again, thus requiring additional sliding or another trip.

The drawbacks to the steerable system make it desirable to be able to make less drastic directional changes and to accomplish this while rotating. Such corrections can readily be made by providing a stabilizer in the assembly that is capable of adjusting its diameter or the position of its blades during operation.

One such adjustable stabilizer known as the Andergage, is commercially available and is described in U.S. Patent Number 4,848,490. This stabilizer adjusts a half-inch diametrically, and when run above a steerable motor, is capable of inclination corrections on the order of \pm one-half a degree per 100 feet, when rotating. This tool is activated by applying weight to the assembly and is locked into position by the flow of the drilling

fluid. This means of communication and actuation essentially limits the number of positions to two, i.e. extended and retracted. This tool has an additional operational disadvantage in that it must be reset each time a connection is made during drilling.

To verify that actuation has occurred, a 200 psi pressure drop is created when the stabilizer is extended. One problem with this is that it robs the bit of hydraulic horsepower. Another problem is that downhole conditions may make it difficult to detect the 200 psi increase. Still another problem is that if a third position were required, an additional pressure drop would necessarily be imposed to monitor the third position. This would either severely starve the bit or add significantly to the surface pressure requirements.

Another limitation of the Andergage is that its one-half inch range of adjustment may be insufficient to compensate for the cumulative variations in drilling conditions mentioned above. As a result, it may be necessary to continue to operate in the sliding mode.

The Andergage is currently being run as a near-bit stabilizer in rotary-only applications, and as a second stabilizer (above the bent motor housing) in a steerable system. However, the operational disadvantages mentioned above have prevented its widespread use.

Another adjustable or variable stabilizer, the Varistab, has seen very limited commercial use. This stabilizer is covered by the following U.S. Patents: 4,821,817; 4,844,178; 4,848,488; 4,951,760; 5,065,825; and 5,070,950. This stabilizer may have more than two positions, but the construction of the tool dictates that it must index through these positions in order. The gauge of the stabilizer remains in a given position,

regardless of flow status, until an actuation cycle drives the blades of the stabilizer to the next position. The blades are driven outwardly by a ramped mandrel, and no external force in any direction can force the blade to retract. This is an operational disadvantage. If the stabilizer were stuck in a tight hole and were in the middle position, it would be difficult to advance it through the largest extended position to return to the smallest. Moreover, no amount of pipe movement would assist in driving the blades back.

To actuate the blade mechanism, flow must be increased beyond a given threshold. This means that in the remainder of the time, the drilling flow rate must be below the threshold. Since bit hydraulic horsepower is a third power function of flow rate, this communication-actuation method severely reduces the hydraulic horsepower available to the bit.

The source of power for indexing the blades is the increased internal pressure drop which occurs when the flow threshold is exceeded. It is this actuation method that dictates that the blades remain in position even after flow is reduced. The use of an internal pressure drop to hold blades in position (as opposed to driving them there and leaving them locked in position) would require a constant pressure restriction, which would even be more undesirable.

A pressure spike, detectable at the surface, is generated when activated, but this is only an indication that activation has occurred. The pressure spike does not uniquely identify the position which has been reached. The driller, therefore, is required to keep track of pressure spikes in order to determine the position of the stabilizer blades. However, complications arise because conditions such as motor stalling, jets plugging, and cuttings building up in the annulus, all can create pressure spikes which may give

false indications. To date, the Varistab has had minimal commercial success due to its operational limitations.

With respect to the tool disclosed in U.S. Patent Number 5,065,825, the construction taught in this patent would allow communication and activation at lower flow rate thresholds. However, there is no procedure to permit the unique identification of the blade position. Also, measurement of threshold flow rates through the use of a differential pressure transducer can be inaccurate due to partial blockage or due to variations in drilling fluid density.

Another adjustable stabilizer recently commercialized is shown in U.S. Patent Number 4,572,305. It has four straight blades that extend radially three or four positions and is set by weight and locked into position by flow. The amount of weight on bit before flow initiates will dictate blade position. The problem with this configuration is that in directional wells, it can be very difficult to determine true weight-on-bit and it would be hard to get this tool to go to the right position with setting increments of only a few thousand pounds per position.

Other patents pertaining to adjustable stabilizers or downhole tool control systems are listed as follows: 3,051,255; 3,123,162; 3,370,657; 3,974,886; 4,270,619; 4,407,377; 4,491,187; 4,572,305; 4,655,289; 4,683,956; 4,763,258; 4,807,708; 4,848,490; 4,854,403; and 4,947,944.

The failure of adjustable stabilizers to have a greater impact on directional drilling can generally be attributed to either lack of ruggedness, lack of sufficient change in diameter, inability to positively identify actual diameter, or setting procedures which interfere with the normal drilling process.

The above methods accomplish control of the inclination of a well being drilled. Other inventions may control the azimuth (i.e. direction in the horizontal plane) of a well. Examples of patents relating to azimuth control include the following: 3,092,188; 3,593,810; 4,394,881; 4,635,736; and 5,038,872.

SUMMARY OF THE INVENTION

The present invention obviates the above-mentioned shortcomings in the prior art by providing an adjustable or variable stabilizer system having the ability to actuate the blades of the stabilizer to multiple positions and to communicate the status of these positions back to the surface, without significantly interfering with the drilling process.

The adjustable stabilizer, in accordance with the present invention, comprises two basic sections, the lower power section and the upper control section. The power section includes a piston for expanding the diameter of the stabilizer blades. The piston is actuated by the pressure differential between the inside and the outside of the tool. A positioning mechanism in the upper body serves to controllably limit the axial travel of a flow tube in the lower body, thereby controlling the radial extension of the blades. The control section comprises novel structure for measuring and verifying the location of the positioning mechanism. The control section further comprises an electronic control unit for receiving signals from which position commands may be derived. Finally, a microprocessor or microcontroller preferably is provided for encoding the measured position into time/pressure signals for transmission to the surface whereby these signals identify the position.

Therefore, in accordance with the present invention, there is provided an adjustable blade stabilizer for use in a drill string located in a borehole, comprising:

a tubular body having a substantially cylindrical outer wall;

6a

said body having a plurality of openings radially extending through the outer wall, said openings being circumferentially spaced about said wall;

a plurality of blades, each blade being movably mounted within a respective opening to extend from a first position to a plurality of positions extending at different radial distances from the tubular body;

drive means for moving the blades from the first position to the plurality of extended positions, wherein the drive means includes a piston movably mounted in the tubular body and axially aligned with said blades; and

remotely controlled positioning means, independent of said drive means, for limiting the radial extent of the blades.

Also in accordance with the present invention, there is provided an adjustable blade stabilizer for use in a drill string, comprising:

a tubular housing with a substantially cylindrical outer wall;

said housing including a plurality of openings extending radially around said cylindrical outer wall;

a plurality of blades, each blade movably mounted within a respective opening to extend radially and axially from a first position to a plurality of positions;

a drive piston driving axial push rods to move said blades in both an axial and radial direction.

Further in accordance with the present invention, there is provided an adjustable blade stabilizer for use in a drill string, comprising:

a tubular body with a substantially cylindrical outer wall;

said body including a plurality of openings extending radially around the circumference of said outer wall;

6b

a plurality of blades, each blade movably mounted within a respective opening to extend radially from a first position to a plurality of positions;

drive means operatively connected to said blades, said drive means being activated to extend said blades when drilling mud is flowing, and being deactivated to permit the blades to retract in the absence of sufficient drilling mud flow; and

remotely controllable positioning means for setting the limits of expansion of said blades.

Still further in accordance with the present invention, there is provided an adjustable blade stabilizer for use in a drill string located in a borehole, comprising:

a tubular body having a substantially cylindrical outer wall;

said body having a plurality of openings radially extending through the outer wall, said openings being circumferentially spaced about said wall;

a plurality of blades, each blade being movably mounted within a respective opening to extend from a first position to a plurality of positions extending at different radial distances from the tubular body;

drive means for moving the blades from the first position to the plurality of extended positions, wherein the drive means includes a piston movably mounted in the tubular body and operatively connected to said blades;

positioning means for limiting the radial extent of the blades; and

measuring means for determining the location of the positioning means for any given point in time and for generating a signal uniquely identifying the position of said blades.

Still further in accordance with the present invention, there is provided an adjustable blade stabilizer for use in a drill string located in a borehole, comprising:

6c

a tubular body having a substantially cylindrical outer wall;

said body having a plurality of openings radially extending through the outer wall,
said openings being circumferentially spaced about said wall;

a plurality of blades, each blade being movably mounted within a respective opening to extend from a first position to a plurality of positions extending at different radial distances from the tubular body;

drive means for moving the blades from the first position to the plurality of extended positions, wherein the drive means includes a piston movably mounted in the tubular body and operatively connected to said blades;

positioning means for setting the radial limit of the blades in response to a command signal;

wherein said positioning means becomes locked in place after being set, and said positioning means does not reset until a new command signal is received.

The above noted objects and advantages of the present invention will be more fully understood upon a study of the following description in conjunction with the

detailed drawings.

BRIEF DESCRIPTION OF THE DRAWINGS

The following drawings will be referred to in the following discussion of the preferred embodiment:

FIGURE 1A is a sectional view of the lower section of the adjustable stabilizer according to the present invention;

FIGURE 1B is a sectional view of the upper section of the adjustable stabilizer of the present invention;

FIGURE 2 is a sectional view taken along lines 2-2 of FIGURE 1A;

FIGURE 3 is an elevational view of the lower section taken along lines 3-3 of FIGURE 1A;

FIGURE 4 is an elevational view showing a stabilizer blade and the push and follower rod assemblies utilized in the embodiment shown in FIGURE 1A;

FIGURE 5 is an elevational view of one embodiment of a bottom hole assembly utilizing the adjustable stabilizer;

FIGURE 6 is an elevational view of a second embodiment of a bottom hole assembly utilizing the adjustable stabilizer of the present invention.

FIGURE 7 is a flow chart illustrating operation of an automatic closed loop drilling system for drilling in a desired formation using the adjustable stabilizer of the present invention;

FIGURE 8 is a flow chart illustrating the operation of an automatic closed loop drilling system for drilling in a desired direction using the adjustable stabilizer of the present invention;

FIGURE 9 is a drawing illustrating the combined time/pulse encoding technique used in the preferred embodiment of the present invention to encode stabilizer position data, and

FIGURE 10 is a diagram illustrating the relationship between the sequence of states and the flow timing.

DESCRIPTION OF THE PREFERRED EMBODIMENTS AND
BEST MODE FOR CARRYING OUT THE INVENTION

Referring now to the drawings, FIGURES 1A and 1B illustrate an adjustable stabilizer, generally indicated by arrow 10, having a power section 11 and a control section 40. The power section 11 comprises an outer tubular body 12 having an outer diameter approximately equal to the diameter of the drill collars and other components located on the lower drill string forming the bottom hole assembly. The tubular body 12 is hollow and includes female threaded connections 13 located at its ends for connection to the pin connections of the other bottom hole assembly components.

The middle section of the tubular body 12 has five axial blade slots 14 radially extending through the outer body and equally spaced around the circumference thereof. Although five slots are shown, any number of blades could be utilized. Each slot 14 further includes a pair of angled blade tracks 15 or guides which are formed in the body 12. These slots could also be formed into separate plates to be removably fitted into the body 12. The function of these plates would be to keep the wear localized in the guides and not on the body. A plurality of blades 17 are positioned within the slots 14 with each blade 17 having a pair of slots 18 formed on both sides thereof for receiving the projected blades tracks 15. It should be noted that the tracks 15 and the corresponding blade slots

8a

18 are slanted to cause the blades 17 to move axially upward as they move radially outward. These features are more clearly illustrated in FIGURES 2, 3 and 4.

Referring back to FIGURE 1A, a multi-sectioned flow tube 20 extends through the interior of the outer tubular body 12. The central portion 21 of the flow tube 20 is integrally formed with the interior of the tubular body 12. The lower end of the flow tube 20 comprises a tube section 22 integrally mounted to the central portion 21. The upper end of the flow tube 20 comprises a two piece tube section 23 with the lower end thereof being slidingly supported within the central portion 21. The upper end of the tube section 23 is slidingly supported within a spacer rib or bushing 24. Appropriate seals 122 are provided to prevent the passage of drilling fluid flow around the tube section 23.

The tube section 22 axially supports an annular drive piston 25. The outer diameter of the piston 25 slidingly engages an interior cylindrical portion 26 of the body 12. The inner diameter of the piston 25 slidingly engages the tube section 22. The piston 25 is responsive to the pressure differential between the flow of the drilling fluid down through the interior of the stabilizer 10 and the flow of drilling fluid passing up the annulus formed by the borehole and the outside of the tube 12. Ports 29 are located on the body 12 to provide fluid communication between the borehole annulus and the interior of the body 12. Seals 27 are provided to prevent drilling fluid flow upwardly past the piston 25.

The cylindrical chamber 26 and the blade slot 14 provide a space for receiving push rods 30. The lower end of each push rod 30 abuts against the piston 25. The upper end of each push rod 30 is enlarged to abut against the lower side of a blade 17. The lower end faces of the blades 17 are angled to match an angled face of the push rod upper end to force the blades 14 against one side of the pocket to maintain contact

therewith (see FIGURE 4). This prevents drilled cuttings from packing between the blades and pockets and causing vibration and abrasive or fretting type wear.

The upper sides of the blades 17 are adapted to abut against the enlarged lower ends of follower rods 35. The abutting portions are bevelled in the same direction as the lower blade abutting connections for the purpose described above. The upper end of each follower rod 35 extends into an interior chamber 36 and is adapted to abut against an annular projection 37 formed on the tube section 23. A return spring 39 is also located within chamber 36 and is adapted to abut against the upper side of the projection 37 and the lower side of the bushing 24.

The upper end of the flow tube 23 further includes a plurality of ports 38 to enable drilling fluid to pass downwardly therethrough.

FIGURE 1B further illustrates the control section 40 of the adjustable stabilizer 10. The control section 40 comprises an outer tubular body 41 having an outer diameter approximately equal to the diameter of body 12. The lower end of the body 41 includes a pin 42 which is adapted to be threadedly connected to the upper box connection 13 of the body 12. The upper end of the body 41 comprises a box section 43.

The control section 40 further includes a connector sub 45 having pins 46 and 47 formed at its ends. The lower pin 46 is adapted to be threadedly attached to the box 43 while the upper pin 47 is adapted to be threadedly connected to another component of the drill string or bottom assembly which may be a commercial MWD system.

The tubular body 41 forms an outer envelope for an interior tubular body 50. The body 50 is concentrically supported within the tubular body 41 at its ends by support rings 51. The support rings 51 are ported to allow drilling fluid flow to pass into the

annulus 52 formed between the two bodies. The lower end of tubular body 50 slidingly supports a positioning piston 55, the lower end of which extends out of the body 50 and is adapted to engage the upper end of the flow tube 23.

The interior of the piston 55 is hollow in order to receive an axial position sensor 60. The position sensor 60 comprises two telescoping members 61 and 62. The lower member 62 is connected to the piston 55 and is further adapted to travel within the first member 61. The amount of such travel is electronically sensed in the conventional manner. The position sensor 60 is preferably a conventional linear potentiometer and can be purchased from a company such as Subminiature Instruments Corporation, 950 West Kershaw, Ogden, Utah 84401. The upper member 61 is attached to a bulkhead 65 which is fixed within the tubular body 50.

The bulkhead 65 has a solenoid operated valve and passage 66 extending therethrough. In addition, the bulkhead 65 further includes a pressure switch and passage 67.

A conduit tube (not shown) is attached at its lower end to the bulkhead 65 and at its upper end to and through a second bulkhead 69 to provide electrical communication for the position sensor 60, the solenoid valve 66, and the pressure switch 67, to a battery pack 70 located above the second bulkhead 69. The batteries preferably are high temperature lithium batteries such as those supplied by Battery Engineering, Inc., of Hyde Park, Massachusetts.

A compensating piston 71 is slidingly positioned within the body 50 between the two bulkheads. A spring 72 is located between the piston 71 and the second bulkhead 69, and the chamber containing the spring is vented to allow the entry of drilling fluid.

The connector sub 45 functions as an envelope for a tube 75 which houses a microprocessor 101 and power regulator 76. The microprocessor 101 preferably comprises a Motorola M68HC11, and the power regulator 76 may be supplied by Quantum Solutions, Inc., of Santa Clara, California. Electrical connections 77 are provided to interconnect the power regulator 76 to the battery pack 70.

Finally, a data line connector 78 is provided with the tube 75 for interconnecting the microprocessor 101 with the measurement-while-drilling (MWD) sub 84 located above the stabilizer 10 (FIGURE 6).

In operation, the stabilizer 10 functions to have its blades 17 extend or retract to a number of positions on command. The power source for moving the blades 17 comprises the piston 25, which is responsive to the pressure differential existing between the inside and the outside of the tool. The pressure differential is due to the flow of drilling fluid through the bit nozzles and downhole motor, and is not generated by any restriction in the stabilizer itself. This pressure differential drives the piston 25 upwardly, driving the push rods 30 which in turn drive the blades 17. Since the blades 17 are on angled tracks 15, they expand radially as they travel axially. The follower rods 35 travel with the blades 17 and drive the flow tube 23 axially.

The axial movement of the flow tube 23 is limited by the positioning piston 55 located in the control section 40. Limiting the axial travel of the flow tube 23 limits the radial extension of the blades 17.

As mentioned previously, the end faces of the blades 17 (and corresponding push rod and follower rod faces) are angled to force the blades to maintain contact with one side of the blade pocket (in the direction of the rotationally applied load), thereby

preventing drilled cuttings from packing between the blade and pocket and causing increased wear.

The blade slots 14 communicate with the body cavity 12 only at the ends of each slot, leaving a tube (see FIGURE 2), integral to the body and to the side walls of each slot, to transmit flow through the pocket area.

In the control section, there are three basic components: hydraulics, electronics, and a mechanical spring. In the hydraulic section, there are basically two reservoirs, defined by the positioning piston 55, the bulkhead 65, and the compensating piston 71. The spring 72 exerts a force on the compensating piston 71 to influence hydraulic oil to travel through the bulkhead passage and extend the positioning system. The solenoid operated valve 66 in the bulkhead 65 prevents the oil from transferring unless the valve is open. When the valve 66 is triggered open, the positioning piston 55 will extend when flow of drilling mud is off, i.e. no force is being exerted on the positioning piston 55 by the flow tube 23. To retract the piston 55, the valve 66 is held open when drilling mud is flowing. The annular piston 25 in the lower power section 11 then actuates and the flow tube 22 forces the positioning piston 55 to retract.

The position sensor 60 measures the extension of the positioning piston 55. The microcontroller 101 monitors this sensor and closes the solenoid valve 66 when the desired position has been reached. The differential pressure switch 67 in the bulkhead 65 verifies that the flow tube 23 has made contact with the positioning piston 55. The forces exerted on the piston 55 causes a pressure increase on that side of the bulkhead.

The spring preload on the compensating piston 71 insures that the pressure in the hydraulic section is equal to or greater than downhole pressure to minimize the

possibility of mud intrusion into the hydraulic system.

The remainder of the electronics (battery, microprocessor and power supply) are packaged in a pressure barrel to isolate them from downhole pressure. A conventional single pin wet-stab connector 78 is the data line communication between the stabilizer and MWD (measurement while drilling) system. The location of positioning piston 55 is communicated to the MWD and encoded into time/pressure signals for transmission to the surface.

FIGURE 5 illustrates the adjustable stabilizer 10 in a steerable bottom hole assembly that operates in the sliding and rotational mode. This assembly preferably includes a downhole motor 80 having at least one bend and a stabilization point 81 located thereon. Although a conventional concentric stabilizer 82 is shown, pads, eccentric stabilizers, enlarged sleeves or enlarged motor housing may also be utilized as the stabilization point. The adjustable stabilizer 10, substantially as shown in FIGURES 1 through 4, preferably is used as the second stabilization point for fine tuning inclination while rotating. Rapid inclination and/or azimuth changes are still achieved by sliding the bent housing motor. The bottom hole assembly also utilizes a drill bit 83 located at the bottom end thereof and a MWD unit 84 located above the adjustable stabilizer.

FIGURE 6 illustrates a second bottom hole assembly in which the adjustable stabilizer 10, as disclosed herein, preferably is used as the first stabilization point directly above the bit 83. In this configuration, a bent steerable motor is not used. This system preferably is run in the rotary mode. The second stabilizer 85 also may be an adjustable stabilizer or a conventional fixed stabilizer may be used. Alternatively, an azimuth controller also can be utilized as the second stabilization point, or between the first and

second stabilization points. An example of such an azimuth controller is shown in U.S. Patent No. 3,092,188.

In the system shown in FIGURE 6, a drill collar is used to space out the first and second stabilizers. The drill collar may contain formation evaluation sensors 88 such as gamma and/or resistivity. An MWD unit 84 preferably is located above the second stabilization point.

In the systems shown in FIGURES 5 and 6, geological formation measurements may be used as the basis for stabilizer adjustment decisions. These decisions may be made at the surface and communicated to the tool through telemetry, or may be made downhole in a closed loop system, using an algorithm such as that shown in FIGURE 7. Alternatively, surface commands may be used interactively with a closed loop system. For example, surface commands setting a predetermined range of formation characteristics (such as resistivity ranges or the like) may be transmitted to the microcontroller, once a particular formation is entered. The actual predetermined range of characteristics may be transmitted from the surface, or various predetermined ranges of characteristics may be preprogrammed in the microcontroller and selected by a command from the surface. Once the range is determined, the microcontroller then implements the automatic closed loop system as shown in FIGURE 7 to stay within the desired formation.

By using geological formation identification sensors, it can be determined if the drilling assembly is still within the objection formation. If the assembly has exited the desired or objective formation, the stabilizer diameter can be adjusted to allow the assembly to re-enter that formation. A similar geological steering method is generally

disclosed in U.S. Patent 4,905,774, in which directional steering in response to geological inputs is accomplished with a turbine and controllable bent member in some undisclosed fashion. As one skilled in the art will immediately realize, the use of the adjustable blade stabilizer, as disclosed herein, makes it possible to achieve directional control in a downhole assembly, without the necessity of surface commands and without the directional control being accomplished through the use of a bent member.

The following describes the operation of the stabilizer control system. Referring still to FIGURES 5 and 6, the MWD system customarily has a flow switch (not shown) which currently informs the MWD system of the flow status of the drilling fluid (on/off) and triggers the powering up of sensors. Timed flow sequences are also used to communicate various commands from the surface to the MWD system. These commands may include changing various parameters such as survey data sent, power usage levels, and so on. The current MWD system is customarily programmed so that a single "short cycle" of the pump (flow on for less than 30 seconds) tells the MWD to "sleep", or to not acquire a survey.

The stabilizer as disclosed herein preferably is programmed to look for two consecutive "short cycles" as the signal that a stabilizer repositioning command is about to be sent. The duration of flow after the two short cycles will communicate the positioning command. For example, if the stabilizer is programmed for 30 seconds per position, two short cycles followed by flow which terminates between 90 and 120 seconds would mean position three.

The relationship between the sequence of states and the flow timing may be illustrated by FIGURE 10.

Timing Parameters:

The timing parameters preferably are programmable and are specified in seconds. The settings are stored in non-volatile memory and are retained when module power is removed.

TSig	<i>Signal Time</i>	The maximum time for a "short" flow cycle.
TDly	<i>Delay Time</i>	The maximum time between "short" flow cycles.
TZro	<i>Zero Time</i>	Flow time corresponding to position 0.
TCmd	<i>Command Time</i>	Time increment per position increment.

A *command cycle* preferably comprises two parts. In order to be considered a valid command, the flow must remain on for at least *TZro* seconds. This corresponds to position zero. Every increment of length *TCmd* that the flow remains on after *TZro* indicates one increment in commanded position. (Currently, if the flow remains on more than 256 seconds during the command cycle, the command will be aborted. This maximum time may be increased, if necessary.)

Following the command cycle, the desired position is known. Referring to FIGURES 1 through 4, if the position is increasing the solenoid valve 66 is activated to move positioning piston 55, thereby allowing decreased movement of the annular drive

piston 25. The positioning piston 55 is locked when the new position is reached. If the position is decreasing, the solenoid valve 66 is activated before mud flow begins again, but is not deactivated until the flow tube 23 drives the positioning piston 55 to retract to the desired position. When flow returns, the positioning piston 55 is forced back to the new position and locked. Thus after the repositioning command is received, the positioning piston 55 is set while flow is off. When flow resumes, the blades 17 expand to the new position by the movement of drive piston 25.

When making a drill string connection, the blades 17 will collapse because no differential pressure exists when flow is off and thus drive piston 25 is at rest. If no repositioning command has been sent, the positioning piston 55 will not move, and the blades 17 will return to their previous position when flow resumes.

Referring now to FIGURES 5 AND 6, when flow of the drilling fluid stops, the MWD system 84 takes a directional survey, which preferably includes the measured values of the azimuth (i.e. direction in the horizontal plane with respect to magnetic north) and inclination (i.e. angle in the vertical plane with respect to vertical) of the wellbore. The measured survey values preferably are encoded into a combinatorial format such as that disclosed in U.S. Patents 4,787,093 and 4,908,804. An example of such a combinatorial MWD pulse is shown in FIGURE 9(C).

Referring now to FIGURE 9(A)-(C), when flow resumes, a pulser (not shown) such as that disclosed in U.S. Patent 4,515,225, transmits the survey through mud pulse telemetry by periodically restricting flow in timed sequences, dictated by the combinatorial encoding scheme. The time pressure pulses

are detected at the surface by a pressure transducer and decoded by a computer. The practice of varying the timing of pressure pulses, as opposed to varying only the magnitude of pressure restriction(s) as is done conventionally in the stabilizer systems cited in prior art, allows a significantly larger quantity of information to be transmitted without imposing excessive pressure losses in the circulating system. Thus, as shown in FIGURE 9(A)-(C), the stabilizer pulse may be combined or superimposed with a conventional MWD pulse to permit the position of the stabilizer blades to be encoded and transmitted along with the directional survey.

Directional survey measurements may be used as the basis for stabilizer adjustment decisions. Those decisions may be made at the surface and communicated to the tool through telemetry, or may be made downhole in a closed loop system, using a method such as that shown in FIGURE 8. Alternatively surface commands may be used interactively in a manner similar to that disclosed with respect to the method of FIGURE 7. By comparing the measured inclination to the planned inclination, the stabilizer diameter may be increased, decreased, or remain the same. As the hole is deepened and subsequent surveys are taken, the process is repeated. In addition, the present invention also can be used with geological or directional data taken near the bit and transmitted through an EM short hop transmission, as disclosed in commonly assigned U.S. Patent No. 5,160,925 issued on November 3, 1992 to Dailey et al.

The stabilizer may be configured to a pulser only instead of to the complete MWD system. In this case, stabilizer position measurements may be encoded into a format which will not interfere with the concurrent MWD pulse transmission. In this encoding format, the duration of pulses is timed instead of the spacing of pulses. Spaced

pulses transmitted concurrently by the MWD system may still be interpreted correctly at the surface because of the gradual increase and long duration of the stabilizer pulses. An example of such an encoding scheme is shown in FIGURE 9.

The position of the stabilizer blades will be transmitted with the directional survey when the stabilizer is run tied-in with MWD. When not connected to a complete MWD system, the pulser or controllable flow restrictor may be integrated into the stabilizer, which will still be capable of transmitting position values as a function of pressure and time, so that positions can be uniquely identified.

It will of course be realized that various modifications can be made in the design and operation of the present invention without departing from the spirit thereof. Thus, while the principal preferred construction and mode of operation of the invention have been explained in what is now considered to represent its best embodiments, which have been illustrated and described, it should be understood that within the scope of the appended claims, the invention may be practiced otherwise than as specifically illustrated and described.

1. An adjustable blade stabilizer for use in a drill string located in a borehole, comprising:

a tubular body having a substantially cylindrical outer wall;

said body having a plurality of openings radially extending through the outer wall, said openings being circumferentially spaced about said wall;

a plurality of blades, each blade being movably mounted within a respective opening to extend from a first position to a plurality of positions extending at different radial distances from the tubular body;

drive means for moving the blades from the first position to the plurality of extended positions, wherein the drive means includes a piston movably mounted in the tubular body and axially aligned with said blades; and

remotely controlled positioning means, independent of said drive means, for limiting the radial extent of the blades.

2. An adjustable blade stabilizer as in claim 1, further comprising;

measuring means for determining the location of the positioning means for any given point in time and for generating a signal correlating to the different positions of said blades.

3. An adjustable blade stabilizer as in claim 1, wherein each of said slots extends axially along the tubular body.

4. An adjustable blade stabilizer as in claim 1, wherein said openings include an angled track and said blades include an angled groove that mates with the track on said opening.

5. An adjustable blade stabilizer as in claim 4, wherein the blades move both axially and radially on said track.

6. An adjustable blade stabilizer as in claim 1, wherein the blades mate with the openings through a tongue and groove attachment.
7. An adjustable blade stabilizer as in claim 1, wherein said drive means comprises a drive piston.
8. An adjustable blade stabilizer as in claim 7, wherein said drive means also includes push rods that connect axially between said drive piston and said blades.
9. An adjustable blade stabilizer as in claim 8, wherein the blades include a first end and a second end and the first end of said blades is bevelled.
10. An adjustable blade stabilizer as in claim 9, wherein the end of said push rods that connect to said blades is bevelled to mate with the bevelled first end of said blades.
11. An adjustable blade stabilizer as in claim 7, wherein the blades extend both axially and radially when said drive piston is activated.
12. An adjustable blade stabilizer as in claim 7, wherein said drive piston is activated by a pressure differential between the interior and exterior of said tubular body.
13. An adjustable blade stabilizer as in claim 12, wherein said drive piston is deactivated when the pressure differential ceases.
14. An adjustable blade stabilizer as in claim 9, further comprising a restraining means that includes follower rods axially connected to the second end of said blades.
15. An adjustable stabilizer as in claim 14, wherein the second end of said blades is bevelled and the end of the follower rods connected to said blades also is bevelled to mate with the second end of said blades.
16. An adjustable stabilizer as in claim 1, wherein said positioning means includes a positioning piston.

17. An adjustable stabilizer as in claim 16, wherein said measuring means includes a position sensor mounted axially in said positioning piston.
18. An adjustable stabilizer as in claim 16, wherein said positioning means also includes a solenoid valve.
19. An adjustable stabilizer as in claim 18, wherein the positioning piston extends axially when the solenoid valve is open and the drive means is deactivated.
20. An adjustable stabilizer as in claim 18, wherein the positioning piston retracts axially when the solenoid valve is open and the drive means is activated.
21. An adjustable stabilizer as in claim 20, wherein the positioning means also includes a compensating spring and a compensating piston for biasing fluid through said valve.
22. An adjustable blade stabilizer for use in a drill string, comprising:
 - a tubular housing with a substantially cylindrical outer wall;
 - said housing including a plurality of openings extending radially around said cylindrical outer wall;
 - a plurality of blades, each blade movably mounted within a respective opening to extend radially and axially from a first position to a plurality of positions;
 - a drive piston driving axial push rods to move said blades in both an axial and radial direction.
23. An adjustable stabilizer as in claim 22, wherein the push rods mate with said blades along a bevelled surface.
24. An adjustable stabilizer as in claim 22, wherein said drive piston only is activated when a sufficient pressure differential exists.
25. An adjustable blade stabilizer for use in a drill string, comprising:
 - a tubular body with a substantially cylindrical outer wall;

said body including a plurality of openings extending radially around the circumference of said outer wall;

a plurality of blades, each blade movably mounted within a respective opening to extend radially from a first position to a plurality of positions;

drive means operatively connected to said blades, said drive means being activated to extend said blades when drilling mud is flowing, and being deactivated to permit the blades to retract in the absence of sufficient drilling mud flow; and

remotely controllable positioning means for setting the limits of expansion of said blades.

26. An adjustable blade stabilizer as in claim 25, further comprising a spring to bias said blades to a retracted position if there is an insufficient flow of drilling mud.

27. An adjustable blade stabilizer as in claim 25, wherein said positioning means receives a command signal indicative of a desired blade setting.

28. An adjustable blade stabilizer as in claim 27, wherein said positioning means does not move when the blades are retracted unless a new command signal is received.

29. An adjustable blade stabilizer as in claim 25, wherein a pressure differential is created when there exists a sufficient flow of drilling mud through said tubular body.

30. An adjustable stabilizer as in claim 29, wherein said drive means comprises a drive piston that is activated if a sufficient differential pressure exists.

31. An adjustable blade stabilizer for use in a drill string located in a borehole, comprising:

a tubular body having a substantially cylindrical outer wall;

said body having a plurality of openings radially extending through the outer wall, said openings being circumferentially spaced about said wall;

a plurality of blades, each blade being movably mounted within a respective opening to extend from a first position to a plurality of positions extending at different radial distances from the tubular body;

drive means for moving the blades from the first position to the plurality of extended positions, wherein the drive means includes a piston movably mounted in the tubular body and operatively connected to said blades;

positioning means for limiting the radial extent of the blades; and

measuring means for determining the location of the positioning means for any given point in time and for generating a signal uniquely identifying the position of said blades.

32. An adjustable blade stabilizer for use in a drill string located in a borehole, comprising:

a tubular body having a substantially cylindrical outer wall;

said body having a plurality of openings radially extending through the outer wall, said openings being circumferentially spaced about said wall;

a plurality of blades, each blade being movably mounted within a respective opening to extend from a first position to a plurality of positions extending at different radial distances from the tubular body;

drive means for moving the blades from the first position to the plurality of extended positions, wherein the drive means includes a piston movably mounted in the tubular body and operatively connected to said blades;

positioning means for setting the radial limit of the blades in response to a command signal;

wherein said positioning means becomes locked in place after being set, and said positioning means does not reset until a new command signal is received.

33. An adjustable blade stabilizer as in claim 32, wherein said positioning means comprises a positioning piston that is axially movable from a fully contracted position to a fully extended position.

34. An adjustable blade stabilizer as in claim 33, wherein said positioning piston may be set at any point between the fully contracted position and the fully extended position.

35. An adjustable stabilizer as in claim 32, further comprising a restraining means operatively connected to said positioning means for restraining said blades from further axial movement in response to the setting of said positioning means.

2 1 0 8 9 1 6

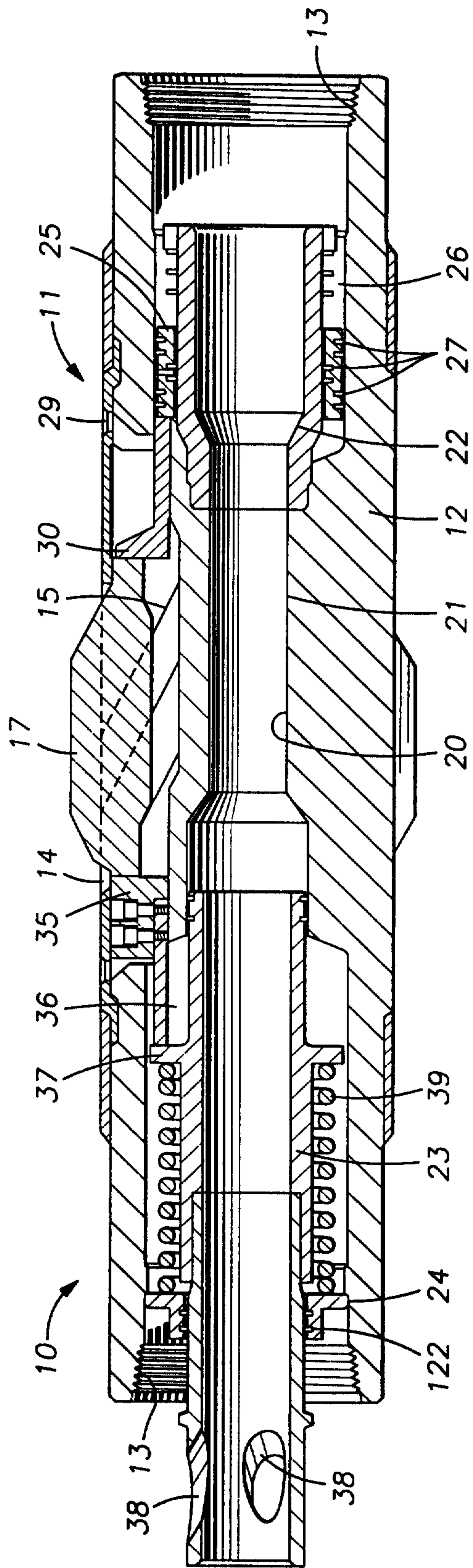

FIG. 1A

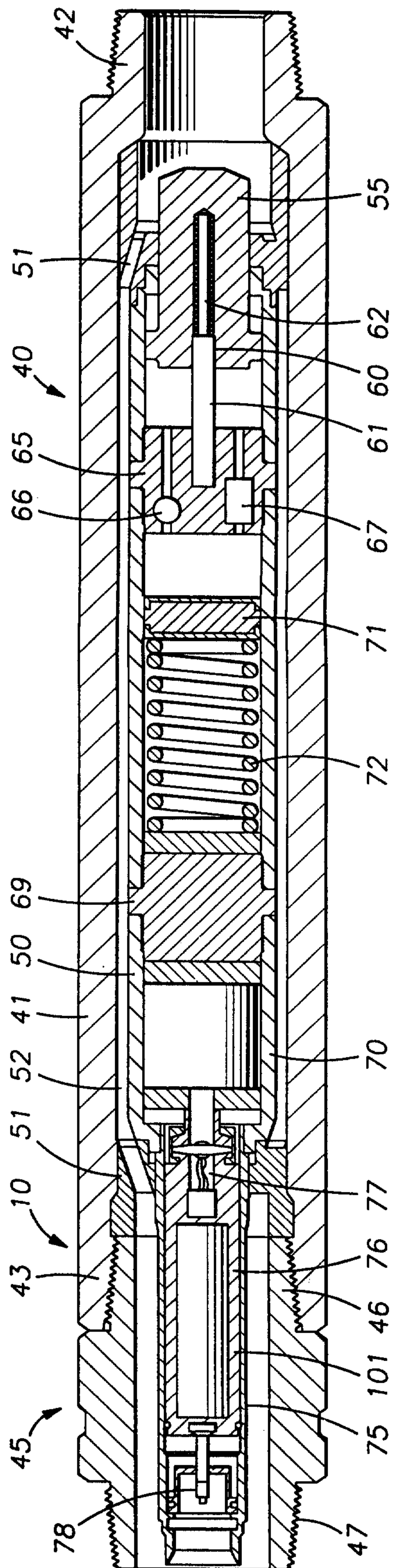
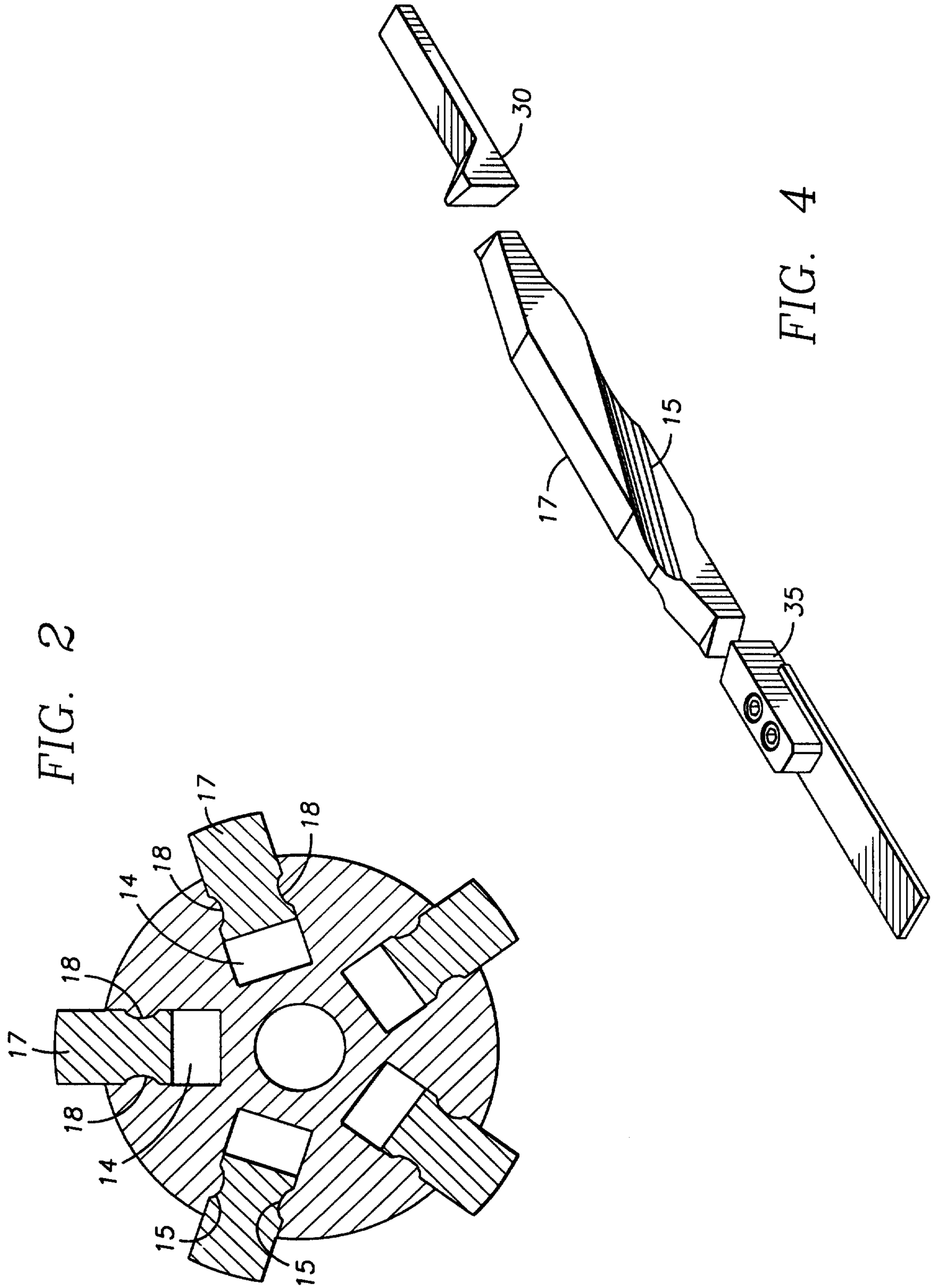

FIG. 1B

PATENT AGENTS

Swasey Ogilvy Renault



PATENT AGENTS

Swanbey Gilbey Renault

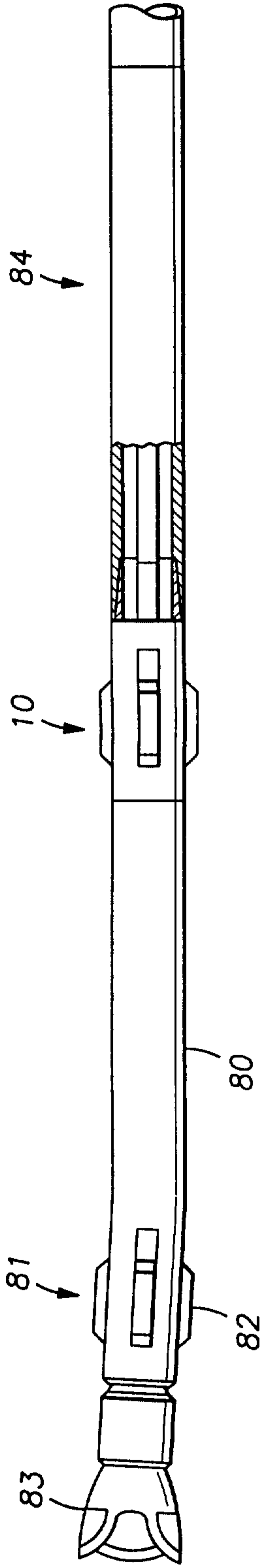

FIG. 5

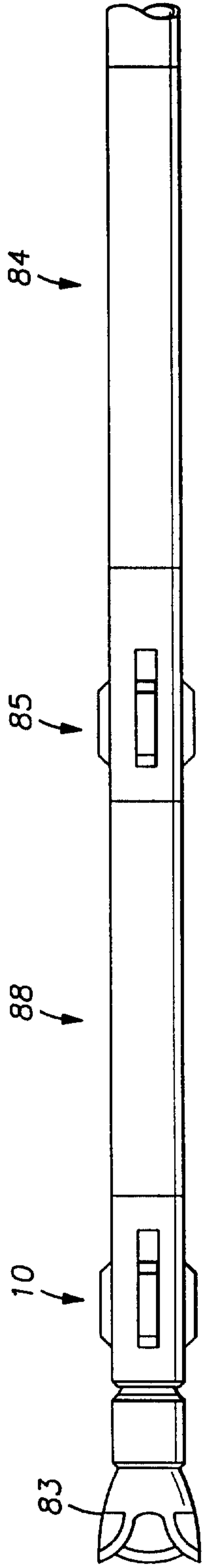

FIG. 6

2 1 0 8 9 1 6

PATENT AGENTS

Awsbey Ogilvy Renault

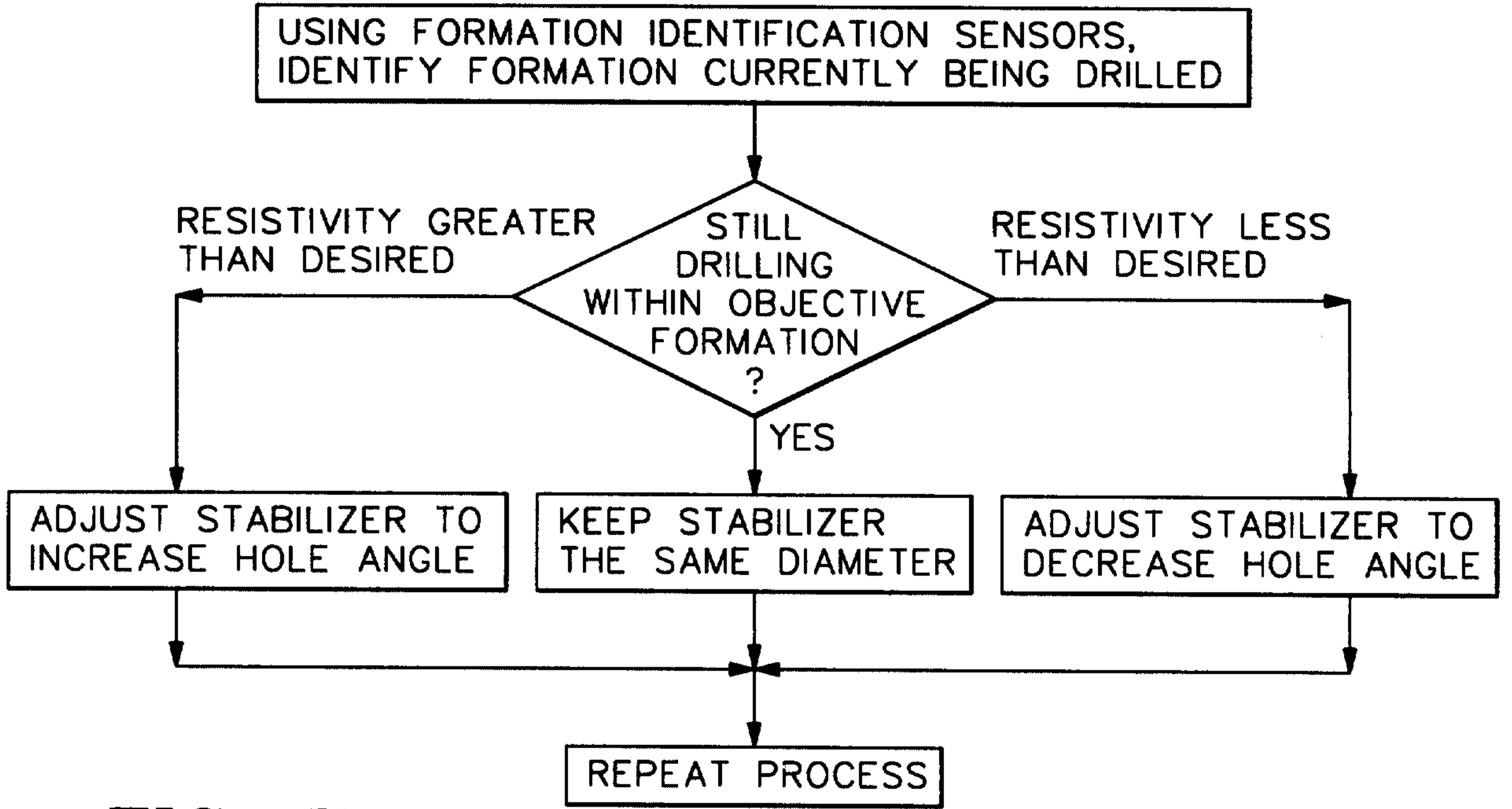

FIG. 7

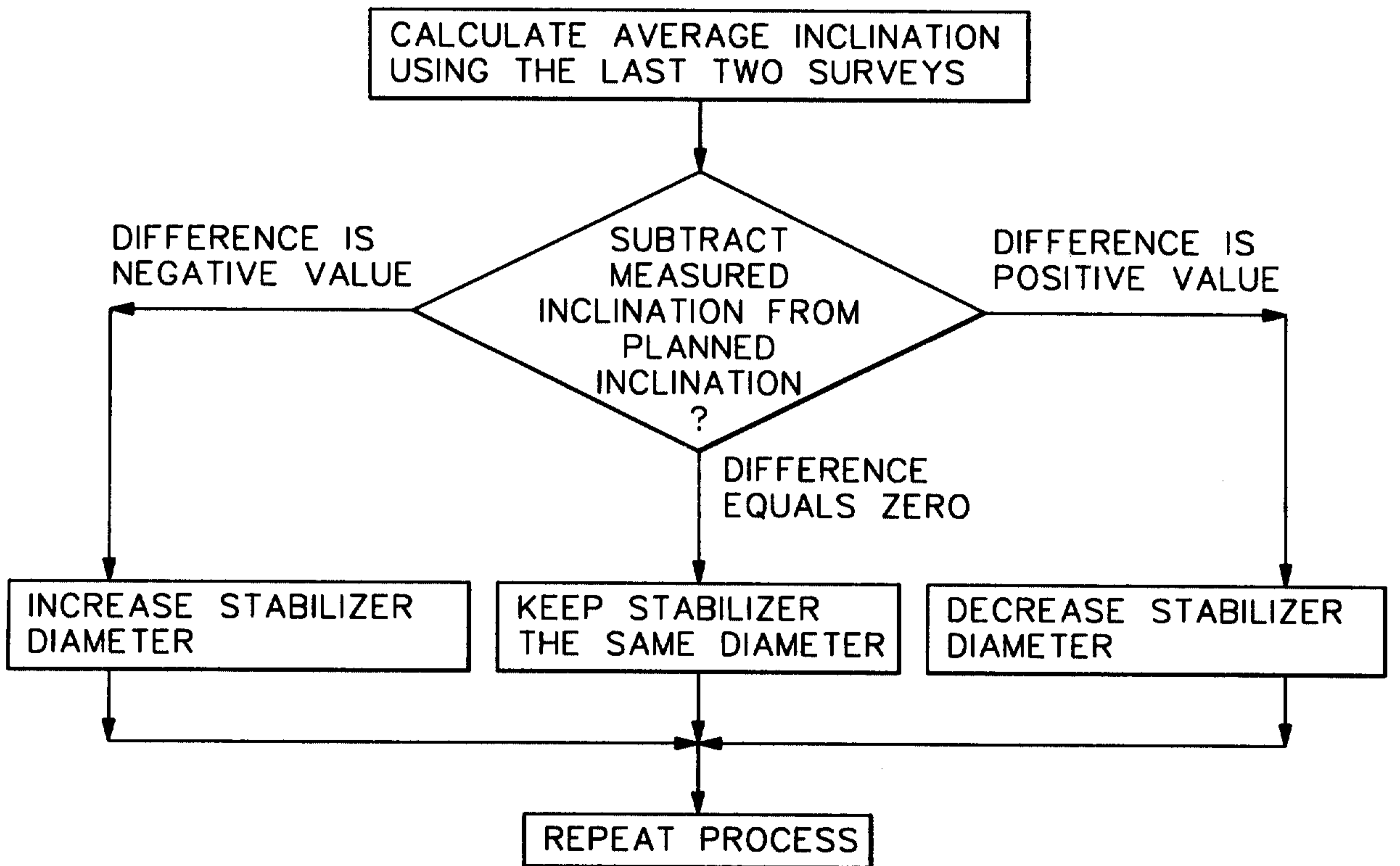

FIG. 8

FIG. 9A



CONVENTIONAL MWD PULSE

FIG. 9B

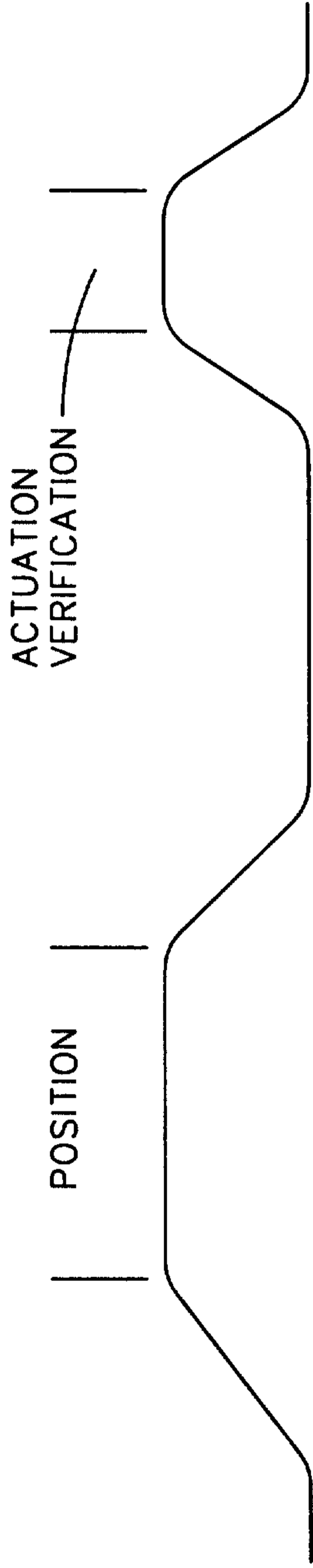

STABILIZER PULSE

FIG. 9C

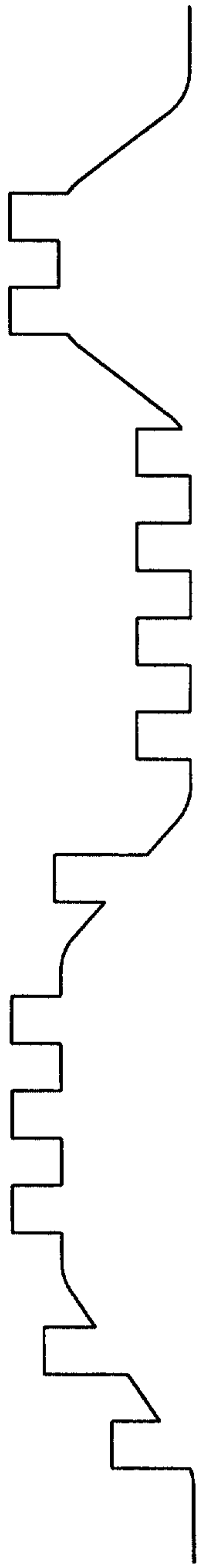

COMBINED PULSE

2 1 0 8 9 1 6

PATENT AGENTS

Aurhey Ogilvy Renault

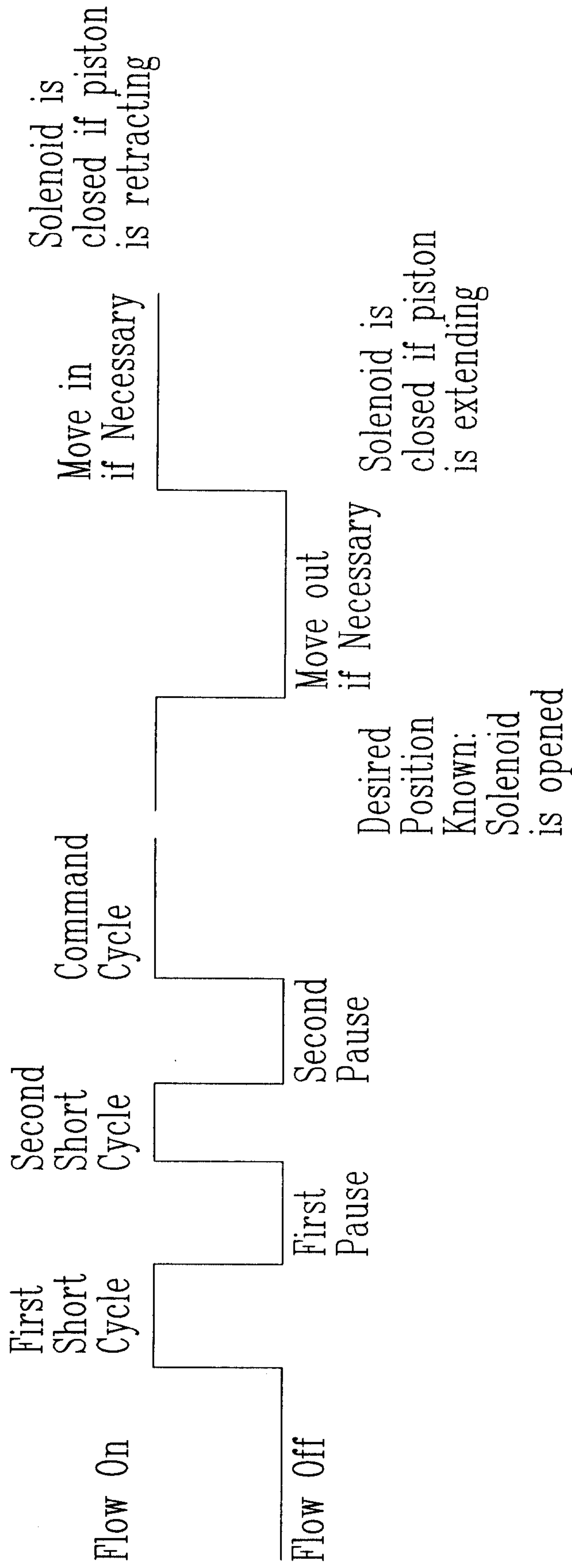

FIG. 10

