

No. 686,882.

Patented Nov. 19, 1901.

W. R. BALLOU.
PADLOCK.

(Application filed Jan. 7, 1901.)

(No Model.)

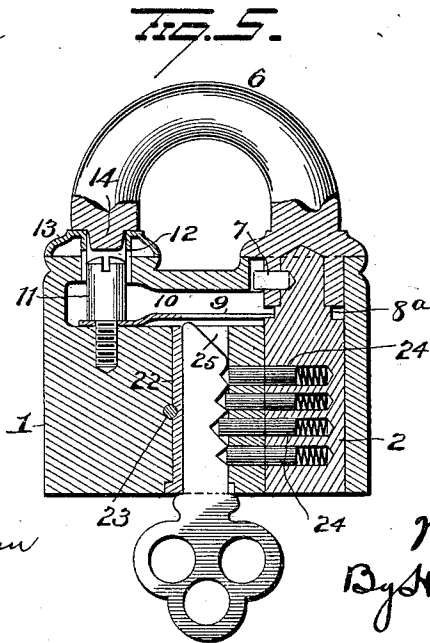
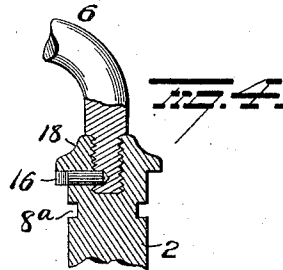
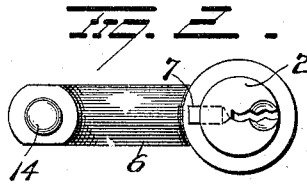
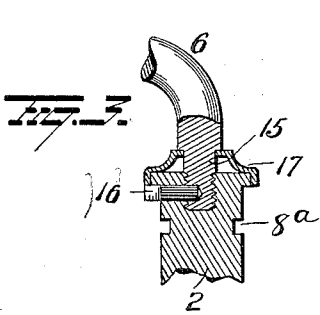
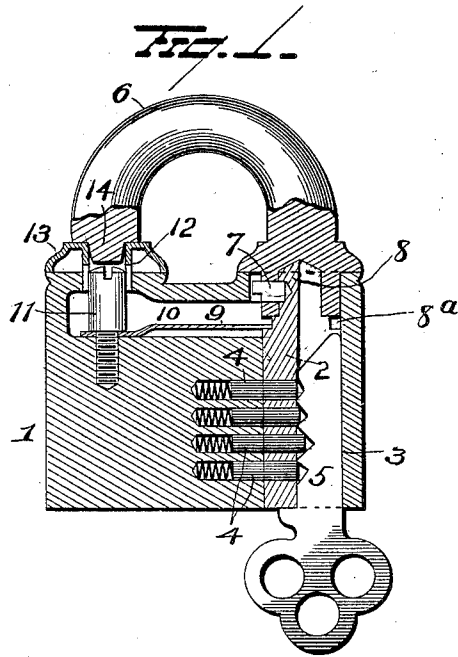

WITNESSES
E. J. Nottingham
A. J. Downing.

INVENTOR
W. R. Ballou
Dy. H. A. Seymour
 Attorney

UNITED STATES PATENT OFFICE.

WALDO R. BALLOU, OF STAMFORD, CONNECTICUT, ASSIGNOR TO THE
YALE & TOWNE MANUFACTURING COMPANY, OF STAMFORD, CON-
NECTICUT.

PADLOCK.

SPECIFICATION forming part of Letters Patent No. 686,882, dated November 19, 1901.

Application filed January 7, 1901. Serial No. 42,412. (No model.)

To all whom it may concern:

Be it known that I, WALDO R. BALLOU, of Stamford, in the county of Fairfield and State of Connecticut, have invented certain new and useful Improvements in Padlocks; and I do hereby declare the following to be a full, clear, and exact description of the invention, such as will enable others skilled in the art to which it appertains to make and use the same.

My invention relates to an improvement in padlocks, the object of the invention being to provide a device of this character which will be simple in construction and operation, easy and comparatively cheap to manufacture, and strong and durable when in use.

With this object in view the invention consists in certain novel features of construction and combinations and arrangements of parts, as will be more fully hereinafter described, and pointed out in the claims.

In the accompanying drawings, Figure 1 is a view in section, illustrating my improvements. Fig. 2 is an end view of the shackle and key-plug removed. Figs. 3 and 4 are views of modified forms of shackles and key-plugs, and Fig. 5 is a view of a modified form of lock.

1 represents the lock-casing, provided at one side with a hole cored or bored through the same to receive the straight key-plug 2, preferably of bronze, which latter is provided with a keyhole 3, projecting nearly through the same transversely and extending from end to end of the plug 2. The plug is made with transverse holes for the accommodation of pin-tumblers 4, of the ordinary construction, mounted in the casing 1, and the meeting ends of said pins are adapted to be alined with the edge of the key-plug 2 by a key 5, inserted in the keyhole 3.

The plug 2 constitutes a leg for the shackle, and its upper end is provided with a lug 8, which is forced into a notch in the lower end of the shackle 6 and secured therein by a pin 7, driven through the shackle and into the lug, the lower end of the shackle being spaced slightly from the upper end of the plug to form a groove or recess 8^a, into which the free end of a flat spring 9 projects. The spring 9 is secured in a horizontal pocket or

recess 10 in the casing 1 by a screw 11, screwed into the casing in alinement with an opening in the top of the casing, over which a cap 13 is secured, and provided with a vertical sleeve 12, in which the upper end of the screw 11 is disposed to hold the cap in place and form a keeper to receive a lug 14 on the free end of the shackle when the pin-tumblers lock the plug and shackle in place.

The spring 9 serves to normally hold the shackle in its locked position and to return it to such position after it has been raised by the key, and the outer end of pin 7 is adapted to aline with a notch in the casing when the shackle is in its locked position, but which when the shackle is raised and turned slightly by the key will rest on the top of the casing and prevent the return of the shackle by the spring 9 until the pin 7 is moved to aline with the notch, when the shackle will be in proper position to be forced into its keeper by the spring 9.

By constructing the plug and shackle separately and afterward securing them together I am enabled to make the keyhole zigzag in cross-section or any other shape desired and am also enabled to use one metal—as, for instance, bronze—for the key-plug and another metal—as, for instance, steel—for the shackle, thus greatly strengthening the lock and at the same time preventing any possibility of rust interfering with the perfect operation thereof.

Instead of constructing the plug and shackle as above described I might make the same as shown in Fig. 3. In this form of my invention the lower end of the shackle is provided with a screw-threaded lug 15, adapted to be screwed into a threaded socket in the upper end of the plug and be secured in place by the pin 16, forced through the plug and into the lug 15, and a finishing or ornamental collar 17 is secured between the shackle and plug by being placed on the lug 15 before the latter is secured in the plug, or I might construct the same as shown in Fig. 4. In this form of my invention the shackle and plug are secured together precisely like that shown in Fig. 3; but the ornamental collar is dispensed with, and instead the upper end of the plug is ornamented as shown at 18, or I

might construct my improvements as shown in Fig. 5. In this form of my invention a key-plug 22 is secured in a recess in the casing 1 beside the leg of the shackle by means of a rivet or pin 23, and said stem and key-plug are made with alined sockets for pin-tumblers 24, which are operated by a key inserted in a keyhole 25 in the plug 22 to align the meeting ends thereof with the juncture of the key-plug and stem to permit the latter and shackle to be raised slightly and turned to unlock the lock, and the spring 9 will return the shackle and stem to their locked position when turned to align the pin 7 with the notch in the casing.

Various other slight changes might be resorted to without departing from my invention, and hence I would have it understood that I do not wish to limit myself to the precise details set forth, but consider myself at liberty to make such slight changes and alterations as fairly fall within the spirit and scope of my invention.

Having fully described my invention, what I claim as new, and desire to secure by Letters Patent, is—

1. In a padlock, the combination with a casing and a longitudinally-movable shackle, of a separate key-plug mounted in the casing and having an irregular key-slot extending from end to end thereof.

2. In a padlock, the combination with a casing, of a shackle and a separate key-plug having a key-slot therein, said plug constituting one leg of the shackle, means securing the shackle to the key-plug and means for securing the shackle to the casing.

3. In a lock, the combination with a casing, of a longitudinally-movable shackle, a leg rigidly and immovably secured to the shackle, pin-tumblers for locking the leg and shackle against movement and a spring in the casing for normally holding the shackle and leg in position to be locked by the tumblers.

4. In a lock, the combination with a casing, of a longitudinally-movable shackle, a leg rigidly and immovably secured to the shackle and having a groove or recess therein, pin-tumblers for locking the shackle-leg against

movement, and a flat spring secured at one end in said casing and having its free end disposed in the groove or recess in the shackle-leg and normally pressing the shackle against the keeper and adapted to return the shackle to its locked position.

5. In a padlock, the combination of a casing, a series of pin-tumblers in said casing and a shackle having a leg locked in the casing by said pin-tumblers, the shackle being made of a separate piece of metal from the leg and rigidly and immovably secured thereto, said leg having an irregular key-slot extending from end to end.

6. In a lock, the combination with a casing and pin-tumblers therein, of a longitudinally-movable key-plug in said casing to be locked against movement by the pin-tumblers and having a keyhole therein, a lug on the end of said plug, a separate shackle having a notch in one end to receive said lug and a pin passing through the shackle and into the lug and securing said shackle and plug rigidly together.

7. In a lock, the combination with a casing and locking means therein, of a longitudinally-movable metal key-plug in said casing to be locked against movement by the locking means and having an irregular key-slot therein for the reception of a key to unlock said locking means, and a shackle composed of a different metal than that of the key-plug and rigidly secured thereto.

8. In a lock the combination with a casing and locking mechanism thereon, of a shackle adapted to be locked against movement by said locking means, a shackle-leg, one of said parts having a lug thereon, the other having a socket for the reception of the lug and a pin passed through the socketed member and into the lug, said pin securing the two parts rigidly together.

In testimony whereof I have signed this specification in the presence of two subscribing witnesses.

WALDO R. BALLOU.

Witnesses:

SCHUYLER MERRITT,
W. S. ABEL.