

(19) World Intellectual Property Organization
International Bureau



(43) International Publication Date
3 January 2002 (03.01.2002)

PCT

(10) International Publication Number
WO 02/00366 A1

- (51) International Patent Classification⁷: **B21D 26/02**
- (21) International Application Number: PCT/SE01/01508
- (22) International Filing Date: 29 June 2001 (29.06.2001)
- (25) Filing Language: Swedish
- (26) Publication Language: English
- (30) Priority Data:
0002450-5 29 June 2000 (29.06.2000) SE
- (71) Applicant (for all designated States except US): **SAAB AUTOMOBILE AB** [SE/SE]; S-461 80 Trollhättan (SE).
- (72) Inventors; and
- (75) Inventors/Applicants (for US only): **HELLGREN, Lars-Olof** [SE/SE]; Vegavägen 1, S-461 59 Trollhättan (SE). **CARLSON, Blair, E.** [US/SE]; Staafsgatan 5, S-461 42 Trollhättan (SE). **ÅGREN, Tomas** [SE/SE]; Pipströmögatan 2, S-461 55 Trollhättan (SE).
- (74) Agent: **ALBIHNS STOCKHOLM AB**; P.O. Box 5581, S-114 85 Stockholm (SE).
- (81) Designated States (national): AE, AG, AL, AM, AT, AU, AZ, BA, BB, BG, BR, BY, BZ, CA, CH, CN, CO, CR, CU, CZ, DE, DK, DM, DZ, EC, EE, ES, FI, GB, GD, GE, GH, GM, HR, HU, ID, IL, IN, IS, JP, KE, KG, KP, KR, KZ, LC, LK, LR, LS, LT, LU, LV, MA, MD, MG, MK, MN, MW, MX, MZ, NO, NZ, PL, PT, RO, RU, SD, SE, SG, SI, SK, SL, TJ, TM, TR, TT, TZ, UA, UG, US, UZ, VN, YU, ZA, ZW.
- (84) Designated States (regional): ARIPO patent (GH, GM, KE, LS, MW, MZ, SD, SL, SZ, TZ, UG, ZW), Eurasian patent (AM, AZ, BY, KG, KZ, MD, RU, TJ, TM), European patent (AT, BE, CH, CY, DE, DK, ES, FI, FR, GB, GR, IE, IT, LU, MC, NL, PT, SE, TR), OAPI patent (BF, BJ, CF, CG, CI, CM, GA, GN, GW, ML, MR, NE, SN, TD, TG).

Published:

— with international search report

For two-letter codes and other abbreviations, refer to the "Guidance Notes on Codes and Abbreviations" appearing at the beginning of each regular issue of the PCT Gazette.

(54) Title: A METHOD FOR PRODUCING A STRUCTURAL ELEMENT WITH A REINFORCED BEND AND A STRUCTURAL ELEMENT

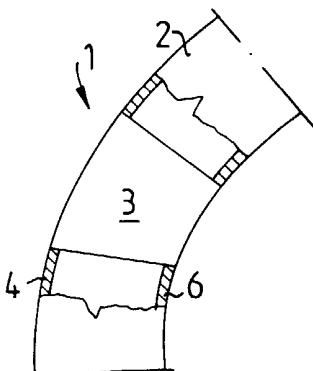

(57) Abstract: A profiled element (1) includes a tubular blank (2) which is formed into the desired shape by hydroforming. In conjunction with hydroforming, at least one slot essentially in the longitudinal direction of the blank is made in wall portions (4, 6) on the blank, and a reinforcing element (3) is fixed in each slot. In a suitable embodiment, each reinforcing element is fixed in two opposite slots and extends through a cavity in the blank. The invention relates to on the one hand a profiled element and on the other hand a method of producing the same.

WO 02/00366 A1

A method for producing a structural element with a reinforced bend and a structural elementTechnical field

5

The present invention relates to on the one hand a method of producing a profiled element, according to the precharacterizing clause of Claim 1, and on the other hand such a profiled element, according to the precharacterizing clause of Claim 7.

10

State of the art

In many types of construction, use is made of profiled elements of different types in order to achieve the desired rigidity and strength. Within the automotive industry, for example, it is customary in many situations to construct, for example, suitable tubular profiled elements from bent sheet-metal components which are welded together. However, the manufacture of such profiled elements requires a number of different working operations and is therefore relatively complicated. Another disadvantage is that the spot welding usually used for joining the component parts together limits the possible strength at a certain material thickness, the joints not being continuous along the profiled element. Another disadvantage is relatively great material consumption and thus great weight.

30

For the purpose of obtaining simpler, lighter and better profiled elements, it is becoming increasingly common to employ hydroforming, which allows great design freedom. Even then, however, problems arise in producing sufficiently rigid profiled elements with as small a material thickness as possible.

35

The object of the invention

The object of the invention is to achieve a simple method of producing a profiled element with good rigidity and with low material consumption. Another object is to produce a simple profiled element with good rigidity and low material consumption.

Disclosure of the invention

10

The object of the invention is achieved by on the one hand employing a method having the features indicated in Patent Claim 1 and on the other hand producing a profiled element having the features indicated in Patent Claim 7.

15

By virtue of the method and embodiment selected, it is possible to reinforce the profiled element locally by simple means without increasing the wall thickness thereof. In this way, good rigidity of the profiled element is obtained with low overall weight.

20

Further advantages and features in a solution according to the invention emerge from the description and the other patent claims.

25

The invention will be described in greater detail below with reference to exemplary embodiments shown in the accompanying drawing.

30

Description of the figures

In the drawing:

Fig. 1 shows a side view of a profiled element according to the invention,

35

Fig. 2 shows a front view of the profiled element in Fig. 1,

Fig. 3 shows a section III-III in Fig. 2,

Fig. 4 shows a view partly in section of a portion of

the profiled element in Fig. 1,
Fig. 5 shows a view corresponding to Fig. 4, but before
mounting of a reinforcing element,
Fig. 6 shows a variant of the embodiment in Fig. 4, and
5 Fig. 7 shows a front view of an embodiment with more
than one reinforcing element.

Description of exemplary embodiments

10 Figs 1-5 show a profiled element 1 made according to
the invention, which is intended, for taking up load,
to be capable of forming part of various types of
construction, which constructions are not shown in
greater detail in this context for the sake of
15 simplification. One possible area of application is as,
for example, a windscreen upright in a motor vehicle,
but a large number of other areas of application are of
course possible, as required and desired. The profiled
element 1 shown includes a blank 2 which is suitably,
20 as in this case, tubular and elongate. At a point which
is sensitive in terms of taking up load, in this case
at a bend, the blank 2 is provided with at least one
reinforcing element 3 which can interconnect mutually
opposite walls in the blank 2.

25
The more detailed design of a profiled element 1 at a
reinforcing point can be seen from Figs 4 and 5. A slot
5, essentially in the longitudinal direction of the
blank 2, is made in a first wall portion 4 on the blank
30 2. In a corresponding manner, a slot 7, which also
extends essentially in the longitudinal direction of
the blank 2, is made in a second, opposite wall portion
6 on the blank 2. A reinforcing element 3, suitably
plate-shaped, is inserted into the two slots 5, 7 and
35 extends through an inner cavity 8 in the blank 2. At
the two slots 5, 7, the reinforcing element 3 is joined
to the blank 2 and thus rigidifies the latter.

An alternative embodiment is shown in Fig. 6, where

only the first wall portion 4 is provided with a slot 5 and where the reinforcing element 3 has a limited extent in the transverse direction of the blank 2. In this connection, the reinforcing element 3 can extend 5 to a greater or lesser extent into the cavity 8, as required and desired.

Fig. 7 shows an embodiment with a double set of reinforcing elements 3, in this case positioned at a certain mutual spacing in the lateral direction. These 10 reinforcing elements can then each be mounted either in two opposite slots 5, 7 in the blank, according to Fig. 4, or in a single slot 5, according to Fig. 6.

15 The number of slots 5, 7 and reinforcing elements 3 and their positioning and design can, over and above what has been shown here, be varied in a number of other different ways within the scope of the invention, as required. For example, it is possible to have both 20 types of reinforcing element 3 shown in Figs 4 and 6 in the same profiled element, if appropriate with relative displacement in the longitudinal direction of the blank 2.

25 Both the blank 2 and the reinforcing element 3 are advantageously made of metal and can be attached to one another in a suitable manner, for example by welding, soldering, adhesive bonding, upsetting or in another way. If appropriate, other materials also can be used, 30 for example plastic of a suitable type.

A particularly advantageous embodiment is obtained if a blank 2 made of metal is used and is given its intended shape by hydroforming. This blank can advantageously be 35 prebent before it is hydroformed. Hydroforming makes it possible to use small wall thicknesses on the finished blank 2 even with a relatively complicated shape, both in the longitudinal direction and in cross section. The rigidity can subsequently be reinforced locally, where

such requirements exist, by means of suitably designed reinforcing elements 3. In conjunction with hydroforming, it is expedient to provide a suitable number of suitably designed and positioned slots in the blank 2 in the hydroforming tool itself. This can take place, for example, after the blank itself has been formed.

The reinforcing element 3 can suitably consist of a plate of uniform thickness, if appropriate provided with cutouts to save weight and material. However, it is also possible to make the reinforcing element wedge-shaped, for example, and then to make the reinforcing element 3 thicker at the slot 5 than at the opposite end. In this case as well, use can be made of cutouts in order to save weight and material.

Patent Claims

1. Method of producing a profiled element, in which a tubular blank (2) is given the desired shape by hydroforming, characterized in that, in conjunction with hydroforming, at least one slot (5), essentially in the longitudinal direction of the blank, is made in a first wall portion (4) on the blank (2), and in that a reinforcing element (3) extending into the inner cavity (8) of the blank is subsequently inserted into and fixed in each slot.

2. Method according to Claim 1, characterized in that at least one slot (7), essentially in the longitudinal direction of the blank, is also made in a second wall portion (6) on the blank (2), located essentially directly opposite the first wall portion (4), and in that at least one reinforcing element (3) inserted into a slot (5) in the first wall portion is inserted into and fixed in such a slot as well.

3. Method according to Claim 1 or 2, characterized in that fixing of a reinforcing element is effected by welding or soldering.

4. Method according to Claim 1 or 2, characterized in that fixing of a reinforcing element is effected by adhesive bonding.

5. Method according to any one of Claims 1-4, characterized in that a blank is provided with at least two reinforcing elements.

6. Method according to any one of Claims 1-5, characterized in that the slotting is carried out in the same tool as the hydroforming.

7. Profiled element which includes a tubular blank (2) which has been given the desired shape by

hydroforming, characterized in that at least one slot (5), which is made in conjunction with hydroforming of the blank and extends essentially in the longitudinal direction of the blank, is present in a first wall portion (4) on the blank (2), and in that a reinforcing element (3) extending into the inner cavity (8) of the blank is fixed in this slot.

8. Profiled element according to Claim 7, characterized in that a slot (7), which extends essentially in the longitudinal direction of the blank, is also present in a second wall portion (6) on the blank, located essentially directly opposite the first wall portion (4), and in that at least one reinforcing element (3) fixed in a slot in the first wall portion (4) is fixed in such a slot as well.

9. Profiled element according to Claim 7 or 8, characterized in that at least one reinforcing element (3) is arranged in a curved portion of the profiled element, and in that the reinforcing element is located essentially in the plane of curvature.

10. Profiled element according to Claim 9, characterized in that the reinforcing element (3) is arranged in two opposite slots (5, 7).

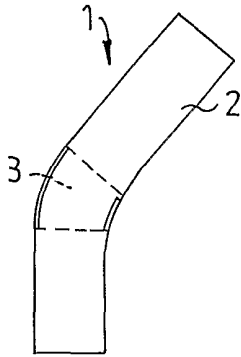

FIG. 1

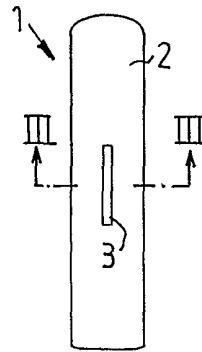

FIG. 2

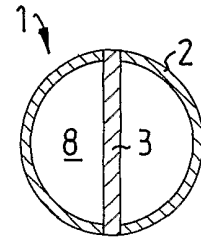

FIG. 3

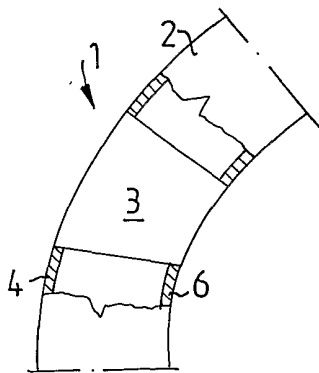

FIG. 4

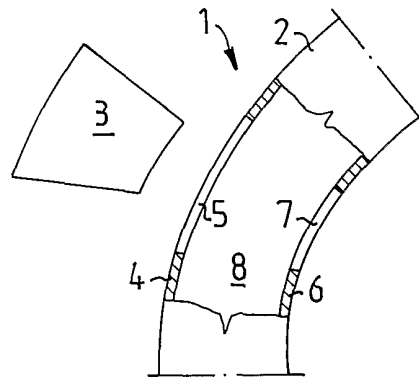

FIG. 5

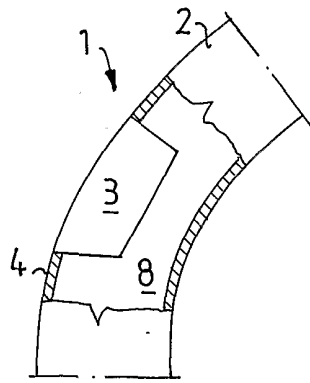

FIG. 6

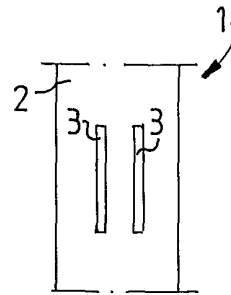

FIG. 7

INTERNATIONAL SEARCH REPORT

International application No.

PCT/SE 01/01508

A. CLASSIFICATION OF SUBJECT MATTER

IPC7: B21D 26/02

According to International Patent Classification (IPC) or to both national classification and IPC

B. FIELDS SEARCHED

Minimum documentation searched (classification system followed by classification symbols)

IPC7: B21D

Documentation searched other than minimum documentation to the extent that such documents are included in the fields searched

SE,DK,FI,NO classes as above

Electronic data base consulted during the international search (name of data base and, where practicable, search terms used)

EPO-INTERNAL, WPI-DATA, PAJ

C. DOCUMENTS CONSIDERED TO BE RELEVANT

Category*	Citation of document, with indication, where appropriate, of the relevant passages	Relevant to claim No.
A	EP 0893332 A1 (HENKEL CORPORATION), 27 January 1999 (27.01.99), figures 1-8, abstract --	1-10
A	EP 0895883 A1 (ALLEVARD RESSORT VEHICULES INDUSTRIELS), 10 February 1999 (10.02.99), figure 2A, abstract --	1-10
A	DE 19833006 A1 (DR. MELEGHY HYDROFORMING GMBH & CO. KG), 3 February 2000 (03.02.00), figures 1,2, abstract --	1-10

 Further documents are listed in the continuation of Box C. See patent family annex.

* Special categories of cited documents:

"A" document defining the general state of the art which is not considered to be of particular relevance

"E" earlier application or patent but published on or after the international filing date

"L" document which may throw doubts on priority claim(s) or which is cited to establish the publication date of another citation or other special reason (as specified)

"O" document referring to an oral disclosure, use, exhibition or other means

"P" document published prior to the international filing date but later than the priority date claimed

"T" later document published after the international filing date or priority date and not in conflict with the application but cited to understand the principle or theory underlying the invention

"X" document of particular relevance: the claimed invention cannot be considered novel or cannot be considered to involve an inventive step when the document is taken alone

"Y" document of particular relevance: the claimed invention cannot be considered to involve an inventive step when the document is combined with one or more other such documents, such combination being obvious to a person skilled in the art

"&" document member of the same patent family

Date of the actual completion of the international search

26 Sept 2001

Date of mailing of the international search report

27 -09- 2001

Name and mailing address of the ISA/

Swedish Patent Office

Box 5055, S-102 42 STOCKHOLM

Facsimile No. +46 8 666 02 86

Authorized officer

Åsa Lööf/MP

Telephone No. +46 8 782 25 00

INTERNATIONAL SEARCH REPORT

International application No.

PCT/SE 01/01508

C (Continuation). DOCUMENTS CONSIDERED TO BE RELEVANT

Category*	Citation of document, with indication, where appropriate, of the relevant passages	Relevant to claim No.
A	US 5653495 A (KENT BOVELLAN ET AL), 5 August 1997 (05.08.97), figures 1-4, abstract -- -----	1-10

INTERNATIONAL SEARCH REPORT

Information on patent family members

03/09/01

International application No.

PCT/SE 01/01508

Patent document cited in search report	Publication date	Patent family member(s)	Publication date
EP 0893332 A1	27/01/99	AU 7398498 A BR 9802437 A DE 29812841 U FR 2762894 A,B GB 2327388 A,B GB 9815900 D IT T0980631 A JP 11165355 A NL 1009643 A,C PL 327390 A TR 9801351 A US 6233826 B ZA 9805834 A	28/01/99 14/03/00 08/10/98 06/11/98 27/01/99 00/00/00 20/01/00 22/06/99 00/00/00 01/02/99 00/00/00 22/05/01 14/01/99
EP 0895883 A1	10/02/99	FR 2766747 A,B	05/02/99
DE 19833006 A1	03/02/00	NONE	
US 5653495 A	05/08/97	DE 4394609 T SE 500174 C SE 9202619 A WO 9406669 A AU 4520793 A EP 0687339 A SE 502497 C SE 9300739 A WO 9420724 A	20/07/95 02/05/94 12/03/94 31/03/94 26/09/94 20/12/95 30/10/95 06/09/94 15/09/94