

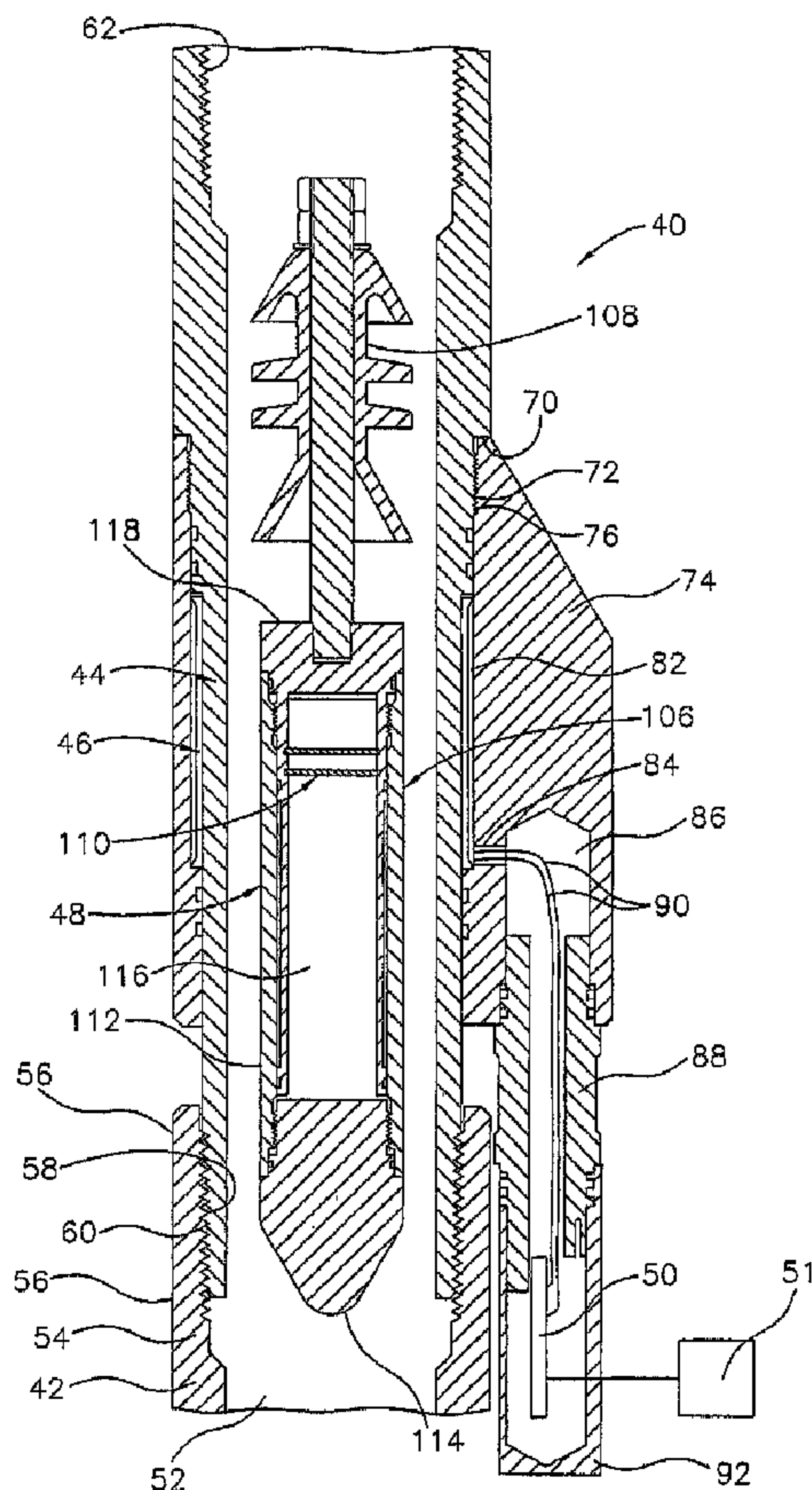

(86) Date de dépôt PCT/PCT Filing Date: 2004/11/30
 (87) Date publication PCT/PCT Publication Date: 2005/06/16
 (45) Date de délivrance/Issue Date: 2009/01/20
 (85) Entrée phase nationale/National Entry: 2006/05/17
 (86) N° demande PCT/PCT Application No.: US 2004/040047
 (87) N° publication PCT/PCT Publication No.: 2005/054876
 (30) Priorité/Priority: 2003/12/01 (US10/726,027)

(51) Cl.Int./Int.Cl. *E21B 47/12* (2006.01)
 (72) Inventeur/Inventor:
 JABUSCH, KIRBY D., CA
 (73) Propriétaire/Owner:
 MARATHON OIL COMPANY, US
 (74) Agent: MACRAE & CO.

(54) Titre : PROCEDE ET SYSTEME PERMETTANT D'ENVOYER DES SIGNAUX A TRAVERS UN ELEMENT
 TUBULAIRE METALLIQUE
 (54) Title: METHOD AND SYSTEM FOR TRANSMITTING SIGNALS THROUGH A METAL TUBULAR



(57) **Abrégé/Abstract:**

A method for transmitting signals through a metal tubular includes the steps of transmitting modulated electromagnetic signals through a non magnetic metal section of the metal tubular, detecting the signals or a field associated with the signals, and

(57) **Abrégé(suite)/Abstract(continued):**

controlling or monitoring devices or operations associated with the metal tubular responsive to the signals. A material, geometry, treatment, and alloying of the non magnetic metal section are selected to optimize signal transmission therethrough. A system for performing the method includes the metal tubular and the non magnetic metal section. The system can also include a transmitter device configured to move through the metal tubular emitting the electromagnetic signals, an antenna on the outside of the non magnetic metal section configured to detect the electromagnetic signals, and a receiver-control circuit configured to generate control signals responsive to the electromagnetic signals.

(12) INTERNATIONAL APPLICATION PUBLISHED UNDER THE PATENT COOPERATION TREATY (PCT)

(19) World Intellectual Property
Organization
International Bureau



(43) International Publication Date
16 June 2005 (16.06.2005)

PCT

(10) International Publication Number
WO 2005/054876 A3

- (51) International Patent Classification⁷: **E21B 47/00** (74) Agent: EBEL, Jack, E.; 165 South Union Boulevard, Suite 902, Lakewood, Colorado 80228 (US).
- (21) International Application Number: PCT/US2004/040047 (81) Designated States (unless otherwise indicated, for every kind of national protection available): AE, AG, AL, AM, AT, AU, AZ, BA, BB, BG, BR, BW, BY, BZ, CA, CH, CN, CO, CR, CU, CZ, DE, DK, DM, DZ, EC, EE, EG, ES, FI, GB, GD, GE, GH, GM, HR, HU, ID, IL, IN, IS, JP, KE, KG, KP, KR, KZ, LC, LK, LR, LS, LT, LU, LV, MA, MD, MG, MK, MN, MW, MX, MZ, NA, NI, NO, NZ, OM, PG, PH, PL, PT, RO, RU, SC, SD, SE, SG, SK, SL, SY, TJ, TM, TN, TR, TT, TZ, UA, UG, US, UZ, VC, VN, YU, ZA, ZM, ZW.
- (22) International Filing Date: 30 November 2004 (30.11.2004)
- (25) Filing Language: English
- (26) Publication Language: English
- (30) Priority Data: 10/726,027 1 December 2003 (01.12.2003) US
- (71) Applicant: MARATHON OIL COMPANY [US/US]; 5555 San Felipe Drive, Houston, TX 77056 (US).
- (72) Inventor: JABUSCH, Kirby, D.; 363 Burton Road, Edmonton, Alberta T5R 2J5 (CA).
- (84) Designated States (unless otherwise indicated, for every kind of regional protection available): ARIPO (BW, GH, GM, KE, LS, MW, MZ, NA, SD, SL, SZ, TZ, UG, ZM, ZW), Eurasian (AM, AZ, BY, KG, KZ, MD, RU, TJ, TM), European (AT, BE, BG, CH, CY, CZ, DE, DK, EE, ES, FI, FR, GB, GR, HU, IE, IS, IT, LU, MC, NL, PL, PT, RO, SE,

[Continued on next page]

(54) Title: METHOD AND SYSTEM FOR TRANSMITTING SIGNALS THROUGH A METAL TUBULAR

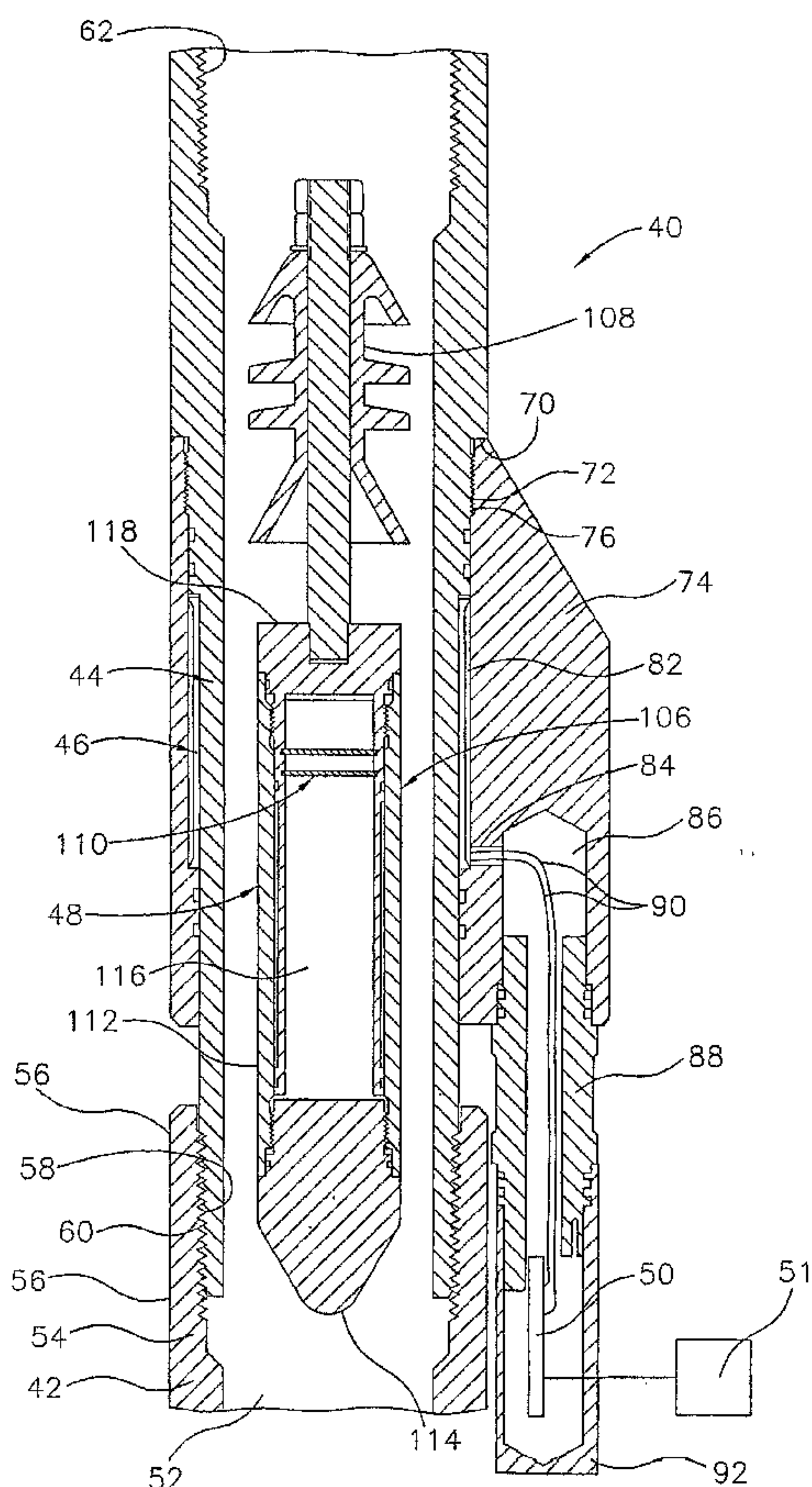

(57) Abstract: A method for transmitting signals through a metal tubular includes the steps of transmitting modulated electromagnetic signals through a non magnetic metal section of the metal tubular, detecting the signals or a field associated with the signals, and controlling or monitoring devices or operations associated with the metal tubular responsive to the signals. A material, geometry, treatment, and alloying of the non magnetic metal section are selected to optimize signal transmission therethrough. A system for performing the method includes the metal tubular and the non magnetic metal section. The system can also include a transmitter device configured to move through the metal tubular emitting the electromagnetic signals, an antenna on the outside of the non magnetic metal section configured to detect the electromagnetic signals, and a receiver-control circuit configured to generate control signals responsive to the electromagnetic signals.

WO 2005/054876 A3

WO 2005/054876 A3



SI, SK, TR), OAPI (BF, BJ, CF, CG, CI, CM, GA, GN, GQ,
GW, ML, MR, NE, SN, TD, TG).

(88) Date of publication of the international search report:
10 November 2005

Published:

— *with international search report*

For two-letter codes and other abbreviations, refer to the "Guidance Notes on Codes and Abbreviations" appearing at the beginning of each regular issue of the PCT Gazette.

**METHOD AND SYSTEM FOR TRANSMITTING SIGNALS
THROUGH A METAL TUBULAR**

5 Field of the Invention

This invention relates generally to signal transmission in metal tubulars, and specifically to a method and a system for transmitting signals through metal tubulars, such as tubulars used in the production of fluids from subterranean wells.

10

Background of the Invention

Various downhole operations are performed during the drilling and completion of a subterranean well, and also during the production of fluids from subterranean formations via the completed well.

15

Representative downhole operations include perforating well casings, installing well devices, controlling well devices, and monitoring well parameters and output. Although downhole operations are performed at some depth within the well, they are typically controlled at the surface. For example, signal transmission conduits, such as electric cables and hydraulic lines, can be used to transfer signals from a depth within the well to a control system at the surface. Components of the control system then process the signals for controlling the downhole operations.

20

A recently developed method for controlling downhole operations employs devices within the well, which are configured to transmit and receive electromagnetic signals, such as radio frequency (RF) signals. These signals can then be used to control a tool or other device in the well, without the need to transmit and process the signals at the surface.

25

30

US Patent No. 6,333,691 B1 to Zierolf, entitled "Method And Apparatus For Determining Position In A Pipe", and US Patent No. 6,536,524 B1 to Snider, entitled "Method And System For Performing A Casing Conveyed Perforating Process And Other Operations In Wells", disclose representative systems which use electromagnetic transmitting and receiving devices. These devices are sometimes referred to as radio frequency identification devices (RFID). Typically, systems employing radio frequency devices require the radio frequency signals to be transmitted from the inside to the outside of the metal tubulars used in the well. In the past this has required penetrating structures such as sealed openings or windows in the metal tubulars.

35

40

5 In general, these penetrating structures are expensive to make, and compromise the structural integrity of the tubulars.

Referring to Figures 1A and 1B, one such prior art system 10 for performing a perforating process in a well 12 using radio frequency signals is illustrated. The well 12 includes a well bore 16, and a well casing 14 within the well bore 16 surrounded by concrete 18. The well 12 extends from an earthen surface (not shown) through geological formations within the earth, which are represented as Zones A, B and C. The well casing 14 comprises a plurality of metal tubulars 20, such as lengths of metal pipe or tubing, attached to one another by collars 22 to form a fluid tight conduit for transmitting fluids.

The system 10 also includes a reader device assembly 24 on the well casing 14; a perforating tool assembly 26 on the well casing 14; a flapper valve assembly 28 on the well casing 14; and an identification device 30 (Figure 1B) configured for movement through the well casing 14. The reader device assembly 24 includes a reader device collar 32 attached to the well casing 14, and a reader device 34 configured to transmit RF transmission signals at a selected frequency to the identification device 30, and to receive RF response signals from the identification device 30. The reader device 34 also includes a control circuit 38 configured to control the operation of the perforating tool assembly 26 and the flapper valve assembly 28 responsive to signals from the identification device 30.

In this system 10, the reader device collar 32 includes an electrically non-conductive window 36, such as a plastic or a composite material, that allows the RF signals to be freely transmitted between the reader device 34 and the identification device 30. One problem associated with the window 36 is that the strength of the well casing 14 is compromised, as a relatively large opening must be formed in the casing 14 for the window 36. In addition, the window 36 requires a fluid tight seal, which can rupture due to handling, fluid pressures or corrosive agents in the well 12. Further, the collar 32 for the window 36 is expensive to manufacture, and expensive to install on the casing 14.

Another approach to transmitting electromagnetic signals in a metal tubular is to place an antenna for an outside mounted reader device on the inside of the tubular, and then run wires from the

5 antenna to the outside of the tubular. This approach also requires openings and a sealing mechanism for the wires, which can again compromise the structural strength and fluid tight integrity of the tubular.

10 It would be advantageous to be able to transmit electromagnetic signals between the inside and the outside of a metal tubular without compromising the strength of the tubular, and without penetrating and sealing the tubular. The present invention is directed to a method and a system for transmitting signals through metal tubulars without penetrating and sealing structures. In addition, the present invention
15 is directed to systems for performing and monitoring operations in wells that incorporate metal tubulars. Further, the present invention is directed to a method for improving production in oil and gas wells using the system and the method.

20 Summary of the Invention

In accordance with the present invention, a method and a system for transmitting signals through a metal tubular are provided. The method, broadly stated, includes the steps of: transmitting electromagnetic signals through a non magnetic metal section of the
25 tubular; detecting the electromagnetic signals, or fields associated with the electromagnetic signals; and controlling or monitoring a device or operation associated with the metal tubular responsive to the detecting step. The electromagnetic signals can comprise modulated signals, such as radio frequency (rf) signals, electric field signals,
30 electromagnetic field signals or magnetic field signals.

The system includes the metal tubular and the non magnetic metal section on the metal tubular. In an illustrative embodiment, the non magnetic metal section comprises a stainless steel tubular segment having a strength that equals or exceeds that of the metal tubular. In
35 addition, the material, geometry, treatment, and alloying of the non magnetic metal section are selected to optimize signal transmission therethrough. The system can also include an antenna outside of the non magnetic metal section, and a transmitter device inside the metal tubular configured to emit electromagnetic signals for transmission
40 through the non magnetic metal section to the antenna.

The system can also include a receiver-control circuit in electrical communication with the antenna, which is configured to detect, amplify, filter and tune the electromagnetic signals, and to transmit signals in response for controlling devices or operations associated with the metal tubular. The receiver-control circuit can also be configured to achieve bi-directional data transfer to the transmitter device for sensing and monitoring devices or operations. In this case the transmitter device can be configured to transmit data to another location, such as the surface, or to store the data for subsequent retrieval.

With the antenna and the receiver-control circuit located outside of the metal tubular, there is no requirement for windows or non metallic joints, which can compromise the structural integrity of the metal tubular. Further, there is no requirement for sealing mechanisms for antenna wires passed between the inside and the outside of the metal tubular.

In accordance with one aspect of the present invention, there is provided a method for transmitting signals through a tubular comprising: transmitting electromagnetic signals through a non-magnetic metal section in the tubular; and selecting a material, a geometry, a treatment and an alloying of the non magnetic section to optimize the transmitting step.

In accordance with another aspect of the present invention, there is provided a signal transmission system comprising: a metal tubular; a non magnetic metal section on the metal tubular; and an antenna outside the tubular proximate to the non magnetic metal section configured to receive electromagnetic signals transmitted through the non magnetic metal section.

25 Brief Description of the Drawings

Figure 1A is a schematic cross sectional view of a prior art perforating system in a subterranean well;

Figure 1B is an enlarged schematic cross sectional view taken along line 1 B of Figure 1A illustrating a reader device and a transmitter device of the prior art system;

Figure 2 is a schematic cross sectional view of a signal transmission system constructed in accordance with the invention;

Figure 3A is a schematic cross sectional view of a receiver-control component of the signal transmission system;

5 Figure 3B is a cross sectional view taken along section line 3B-3B of Figure 3A;

Figure 3C is a cross sectional view taken along section line 3C-3C of Figure 3A;

Figure 3D is an enlarged view taken along line 3D of Figure 3A;

10 Figure 3E is a cross sectional view taken along section line 3E-3E of Figure 3A;

Figure 3F is a cross sectional view taken along section line 3F-3F of Figure 3A;

5 Figure 4A is a schematic plan view of an antenna component of the signal transmission system;

Figure 4B is a schematic elevation view of the antenna component;

10 Figure 5 is an electrical schematic of a receiver-control circuit component of the signal transmission system;

Figure 6A is a schematic cross sectional view of a transmitter component of the signal transmission system;

Figure 6B is a cross sectional view taken along section line 6B-6B of Figure 6A;

15 Figure 6C is an electrical schematic of a transmitter circuit of the signal transmission system;

Figures 7A and 7B are schematic cross sectional views of a perforating system in a subterranean well which incorporates the signal transmission system;

20 Figures 8A and 8B are schematic cross sectional views of a packer system in a subterranean well which incorporates the signal transmission system; and

25 Figures 9A and 9B are schematic cross sectional view of a sensing and monitoring system in a subterranean well which incorporates the signal transmission system.

Detailed Description of the Preferred Embodiment

Referring to Figure 2, a signal transmission system 40 constructed in accordance with the invention is illustrated. The system 40 includes a metal tubular 42, a non magnetic metal section 30 44 attached to the metal tubular 42, and an antenna 46 on the outside of the non magnetic metal section 44.

35 The system 40 also includes a transmitter device 48 inside the metal tubular 42 configured to emit electromagnetic signals, and a receiver-control circuit 50 configured to detect, amplify, filter and tune the electromagnetic signals, and to transmit signals in response, for controlling devices and operations 51 associated with the metal tubular 42.

40 The receiver-control circuit 50 can also be configured to emit signals for reception by the transmitter device 48, such that bi-directional data transfer through the non magnetic metal section 44

5 can be achieved. In this case the transmitter device 48 can be configured to transmit data to another location, such as a surface control panel, or to store data for subsequent retrieval.

The devices and operations 51 of the signal transmission system 40 are schematically represented by a block. Representative devices
10 include perforating devices, packer devices, valves, sleeves, sensors, fluid analysis sensors, formation sensors and control devices. Representative operations include perforating operations, packer operations, valve operations, sleeve operations, sensing operations, monitoring operations, fluid analysis operations, formation operations
15 and control operations.

For simplicity, the metal tubular 42 is shown as being located on only one side of the non magnetic metal section 44. However, in actual practice the non magnetic metal section 44 would likely be located at a mid point of the metal tubular 42, such that segments of
20 the metal tubular 42 are on opposing ends of the non magnetic metal section 44. The metal tubular 42, and the non magnetic metal section 44, thus form a fluid tight conduit for transmitting fluids, such as oil and gas from a subterranean well.

In the illustrative embodiment, the metal tubular 42 comprises
25 lengths of pipes or tubes attached to one another by joining members (not shown), such as collars, couplings, mating threads or weldments. The metal tubular 42 has a generally cylindrical configuration, and includes an inside portion 52, a sidewall portion 54, and an outside portion 56. In addition, the metal tubular 42 includes a female pipe
30 thread 58 configured to threadably engage a male pipe thread 60 on the non magnetic metal section 44. Further, the non magnetic metal section 44 includes a female pipe thread 62, and the metal tubular 42 includes a segment (not shown) threadably attached to the female pipe thread 62.

35 Referring to Figures 3A-3F, the non magnetic metal section 44 is illustrated in greater detail. In the illustrative embodiment, the non magnetic metal section 44 comprises a metal tubular segment, that is similar in size and shape to the metal tubular 42, but which is made of a non magnetic metal.

40 As shown in Figure 3B, the non magnetic metal section 44 includes an inside portion 64, a sidewall portion 66, and an outside

5 portion 68. The inside diameter of the inside portion 64, the thickness
of the sidewall portion 66, and the outside diameter of the outside
portion 68 vary along the length of the non magnetic metal section 44
to accommodate various features thereof. In the illustrative
embodiment, the inside diameter of the inside portion 64, and the
10 outside diameter of the outside portion 68, are approximately equal to
the inside diameter and the outside diameter of the metal tubular 42.

In accordance with the invention, the material, treatment,
alloying and geometry of the non magnetic metal section 44 are
selected to optimize signal transmission through the non magnetic
15 metal section 44. As used herein the term "signal transmission
through the non magnetic metal section 44" means the
electromagnetic signals are electrically conducted through the sidewall
66 of the non magnetic metal section 44. In this regard, the non
magnetic metal section 44 is selected to have a high electrical
20 conductivity such that the electromagnetic signals are efficiently
conducted through the sidewall 66 without a substantial loss of power.

In the illustrative embodiment, the non magnetic metal section
44 comprises a non magnetic stainless steel. One suitable stainless
steel is "Alloy 15-15LC", which comprises a nitrogen strengthened
25 austenitic stainless steel available from Carpenter Technology
Corporation of Reading, PA. This stainless steel has a strength which
meets or exceeds that of the metal tubular 42, such that the strength
of the metal tubular 42, or a tubing string formed by the metal tubular
42, is not compromised. Other suitable alloys for the non magnetic
30 metal section 44 include various "Inconel" alloys (Inc 600, 625, 725,
825, 925) available from Inco Alloys International LTD., of Canada, and
"Hastelloy" alloys (C-276, G22) available from Haynes International,
Inc. of Kokomo, IN.

Also in the illustrative embodiment, the non magnetic metal
35 section 44 includes a segment 80 proximate to the antenna 46 having
a thickness T and an outside diameter OD. The thickness T, and the
outside diameter OD of the segment 80 (along with the length L of
the antenna 46), are selected to optimize signal transmission from the
transmitter device 48 to the antenna 46. A representative range for
40 the thickness T can be from about 5 mm to 10 mm. A representative

5 range for the outside diameter OD can be from about 5 cm to 40 cm depending on tubing, casing and bore hole sizes.

As also shown in Figure 3C, the non magnetic metal section 44 includes a circumferential flat 70, and male threads 72 on the outside portion 68 thereof. The circumferential flat 70 and the male threads
10 72, are configured for mounting a y-block member 74, which is configured to house and seal the antenna 46 and the receiver-control circuit 50. The y-block member 74 includes female threads 76, configured to threadably engage the male threads 72 on the non magnetic metal section 44.

15 As shown in Figure 3C, the y-block member 74 has a generally asymmetrical Y shape with a variable thickness. As shown in Figure 3D, the non magnetic metal section 44 also includes pairs of grooves 77 and sealing members 78, such as o-rings, which function to seal one end of the antenna 46 from the outside. As shown in Figure 3A,
20 other pairs of sealing members 78 on the Y-block member 74 are located proximate to an opposing end of the antenna 46, such that the antenna 46 is sealed on both ends.

The y-block member 74 can be formed of the same non magnetic material as the non magnetic metal section 44. Alternately,
25 the y-block member 74 can be formed of a different magnetic or non magnetic material. Suitable materials for the y-block member 74 include steel and stainless steel.

As shown in Figure 3E, the y-block member 74 is shaped to form a sealed space 82 wherein the antenna 46 is located. As shown in
30 Figure 3A, the y-block member 74 includes an opening 84 to the sealed space 82. In addition, the y-block member 74 includes a threaded counterbore 86, and a threaded nipple 88 threadably attached to the counterbore 86. Wires 90 extend through the opening 84, through the counterbore 86 and through the threaded
35 nipple 88. In addition, the wires 90 are electrically connected to the antenna 46 and to the receiver-control circuit 50. The y-block member 74 also includes a cap member 92, which along with the threaded nipple 88, is configured to house and seal the receiver-control circuit 50.

40 Referring to Figures 4A and 4B, the antenna 46 is shown separately. The antenna 46 includes a wire coil 94 wrapped around a

5 non conductive sleeve member 96. The wire coil 94 terminates in wire
ends 98, which are placed in electrical communication with the wires
90 and the receiver-control circuit 50 (Figure 2). The antenna 46 is
configured to receive (or detect) electromagnetic signals emitted by
the transmitter device 48, or secondary fields associated with the
10 electromagnetic signals. In addition, the length L of the wire coil 94 is
selected to optimize reception of the electromagnetic signals from the
transmitter device 48. In particular the length L is optimized based on
data transmission speed, volume of data, and relative velocity of the
transmitter device 48 relative to the antenna 46. A representative
15 range for the length L can be from about 1 mm to 30 mm. In the case
of bi directional data transfer, the antenna 46 can be configured to
transmit electromagnetic signals from the receiver-control circuit 50
to the transmitter device 48.

The sleeve member 96 of the antenna 46 comprises a non
20 conductive material, such as paper, plastic, fiberglass or a composite
material. In addition, the sleeve member 96 has an inside diameter ID
which is approximately equal to, or slightly larger than, the outside
diameter OD (Figure 3E) of the segment 80 of the non magnetic metal
section 44.

25 Referring to Figure 5, elements of the receiver-control circuit 50
are shown in an electrical schematic. The receiver-control circuit 50
detects, amplifies, filters and decodes electromagnetic signals received
(or detected) by the antenna 46. The receiver-control circuit 50
includes an antenna control circuit 100, and a detector circuit 103,
30 both of which are in electrical communication with the antenna 46.
The detector circuit 103 is configured to detect and decode the
electromagnetic signals transmitted by the transmitter device 48
through segment 80 of the non magnetic metal section 44 to the
antenna 46. The electromagnetic signals, although minute, can be
35 directly radiated through the non magnetic section 44 and detected
by the antenna 46 and the detector circuit 103. Alternately, the
electromagnetic signals can produce a secondary field on the outside
of the non magnetic section 44 due to the secondary effect of reverse
currents. The detector circuit 103 and the antenna 46 can also be
40 configured to detect such a secondary field.

5 The receiver-control circuit 50 also includes a processing-
memory circuit 102 configured to process the electromagnetic signals
in accordance with programmed information, or remote
contemporaneous commands from an outside device (not shown).
The receiver-control circuit 50 also includes a device control circuit
10 104 configured to control the devices and operations 51 responsive to
the signals and programmed information. The receiver-control circuit
50 also includes a battery 105 or other power source, and can include
electronic devices such as resistors, capacitors, and diodes arranged
and interconnected using techniques that are known in the art.

15 In addition, the receiver-control circuit 50 can range from
discrete components to a highly integrated system on a chip type
architecture. As such, the design can consist of many discrete
components to a highly integrated design involving software with
digital signal processors and programmable logic. In the illustrative
20 embodiment, the overall function of the receiver-control circuit 50 is
to decode the electromagnetic signals and extract the binary
information therefrom. However, the receiver-control circuit 50 can
also be configured to generate electromagnetic signals from devices
such as sensors. In this case the receiver-control circuit 50 can be
25 configured to transmit signals to the transmitter device 48 or to
another device, such as a control panel.

Referring to Figures 6A and 6B, the transmitter device 48 is
shown separately. The transmitter device 48 includes a housing 106,
and a transmitter circuit 110 mounted within the housing 106. The
30 housing 106 includes a generally cylindrical body 112 having a sealed
inner chamber 116 wherein the transmitter circuit 110 is mounted.
The housing 106 also includes a generally conically shaped nose
section 114, which threadably attaches to the body 112. In addition,
the housing 106 includes a base section 118 which threadably
35 attaches to the body 112. Suitable materials for the housing include
fiberglass composite, ceramic, and non-conductive RF and magnetic
field permeable materials.

The housing 106 also includes a wire line pig 108 attached to
the base section 118. The wire line pig 108 allows the transmitter
40 device 48 to be attached to a wire line (not shown), or a slick line (not
shown), and moved through the metal tubular 42, and through the non

5 magnetic metal section 44 proximate to the antenna 46. In addition, the wire line pig 108, and associated wire line (not shown), can be configured to conduct signals from the transmitter device 48 to another location, such as a surface control panel.

10 The wire line pig 108 can be in the form of a wireline fish neck, a wire line latching device, or a pump down pig. In addition, the wire line pig 108 can be used as a parachute to slow the drop of the transmitter device 48 (as shown in Figure 2), or alternately can be reversed and the cup shape at one end used to pump the transmitter device 48 into a horizontal well bore. Rather than the wire line pig
15 108, the transmitter device 48 can be configured for movement through the metal tubular 42 and the non magnetic metal section 44 using any suitable propulsion mechanism such as pumping, gravity, robots, motors, or parachutes.

20 Referring to Figure 6C, the transmitter circuit 110 is shown in an electrical schematic diagram. The transmitter circuit 110 includes a transmitter coil-capacitor 120 in electrical communication with a signal drive circuit 122, and with an oscillator 124 which is configured to modulate the electromagnetic signals. The transmitter circuit 110 also includes a command control circuit 126 configured to control signal
25 transmission to the transmitter coil-capacitor 120. The transmitter circuit 110 also includes a battery 128 (or other power source) configured to power the components of the transmitter circuit 110.

30 The transmitter circuit 110 can also include electronic devices (not shown) such as resistors, capacitors and diodes arranged and interconnected using techniques that are known in the art. Further, the transmitter circuit 110 can include electronic devices, such as memory chips, configured to store data for subsequent retrieval. As another alternative, the transmitter circuit 110 can include electronic devices configured to transmit data to a remote location, such as a
35 surface control panel.

Although any type of electromagnetic signals can be employed, in the illustrative embodiment the electromagnetic signals are modulated signals. As such, any suitable modulation format can be used to transmit a series of binary information representative of
40 commands. Representative modulation formats include PSK (phase shift keying), FSK (frequency shift keying), ASK (amplitude shift

5 keying), QPSK (quadrature phase shift keying), QAM (quadrature
amplitude modulation), and others as well, such as spread spectrum
techniques. In addition, any modulation technique using various
combinations of modulating phase frequency or amplitude can be used
to transmit a binary data sequence or other information. Further, even
10 the presence of a non-modulated specific signal or frequency could be
used to trigger a command or a device. In this case no modulation is
necessary, only the presence or absence of a specific signaling means
or signal pattern.

For practicing the method of the invention, the tubular 42 is
15 provided with the non magnetic metal section 44 having the antenna
46 and the receiver-control circuit 50 configured as previously
described. The transmitter device 48 is also provided as previously
described, and is moved through the tubular 42 by a suitable propulsion
mechanism, such as a wire line or a slick line. During movement
20 through the tubular 42, the transmitter device 48 can continuously
transmit electromagnetic signals. As the transmitter device 48
approaches and moves through the non magnetic metal section 44,
the electromagnetic signals radiate through the non magnetic metal
section 44, and are detected by the antenna 46 and the detector
25 circuit 103 of the receiver-control circuit 50. Alternately, the
electromagnetic signals can cause a secondary field on the outside of
the non magnetic metal section 44, which can be detected by the
antenna 46 and the detector circuit 103 of the receiver-control circuit
50. The receiver-control circuit 50 then amplifies, filters and tunes the
30 electromagnetic signals, and transmits appropriate control signals to
the devices and operations 51. Alternately for bi directional data
transfer the receiver-control circuit 50 can be configured to transmit
data back to the transmitter device 48, or to another element such as
a control panel.

35 Referring to Figures 7A and 7B, a perforating system 132 which
incorporates the signal transmission system 40, is illustrated in a
subterranean well 130, such as an oil and gas well. The well 130
extends from an earthen surface (not shown) through different
geological formations within the earth, such as geological Zone A and
40 geological Zone B. The well 130 includes the metal tubular 42 having
the inside portion 52 configured as a fluid tight conduit for

5 transmitting fluids into and out of the well 130. The well 130 also includes a well bore 136, and concrete 138 in the well bore 136 surrounding the outer portion 56 of the metal tubular 42.

The signal transmission system 40 is located at a middle portion of the metal tubular 42, and within Zone A, substantially as previously
10 described. The perforating system 132 also includes a perforating device 144 in Zone B, configured to perforate the metal tubular 42 and the concrete 138, to establish fluid communication between Zone B and the inside portion 52 of the metal tubular 42. A control conduit 146 establishes signal communication between the receiver-control
15 circuit 50 of the system 40 and the perforating device 144. In addition, the exterior of the system 40 and the perforating device 144 are embedded in the concrete 138.

As shown in Figure 7A, the transmitter device 48 of the system 40 is moved through the metal tubular 42 by a wire line 134 (or a slick
20 line), as indicated by directional arrow 142. As the transmitter device 48 moves through the metal tubular 42 electromagnetic signals 140 are continuously (or intermittently) emitted, substantially as previously described. As shown in Figure 7B, when the transmitter device 48 comes into proximity to the antenna 46, the electromagnetic signals
25 140 are detected by the antenna 46. Upon detection of the electromagnetic signals 140, the receiver-control circuit 50 amplifies, filters and tunes the signals and sends control signals to actuate the perforating device 144. Actuation of the perforating device 144 then forms perforations 148 in the metal tubular 42 and in the concrete
30 138. In this embodiment the perforating system 132 and the signal transmission system 40 can be used to improve production from the well 130.

Referring to Figures 8A and 8B, a packer system 150 which incorporates the signal transmission system 40 is illustrated in a
35 subterranean well 158, such as an oil and gas well. The well 158 is substantially similar to the previously described well 130. However, the well 158 includes a well casing 152 embedded in concrete 138, and the metal tubular 42 is located within an inside diameter 154 of the casing 152. The packer system 150 also includes a packer device
40 156 connected to the metal tubular 42. The packer device 156 is configured for actuation by the receiver-control circuit 50 from the

5 uninflated condition of Figure 8A to the inflated condition of Figure 8B. In the inflated condition of Figure 8B the packer device 156 seals the inside diameter 154 of the casing 152 but allows fluid flow through the metal tubular 42. The packer device 156 is controlled by the signal transmission system 40 substantially as previously described for
10 the perforating system 132 (Figures 7A-7B).

Referring to Figures 9A and 9B, a sensing and monitoring system 160 which incorporates a bi-directional signal transmission system 40B is illustrated in a subterranean well 162, such as an oil and gas well. The well 162 is substantially similar to the previously described well
15 158 (Figure 8A). The sensing and monitoring system 160 includes a sensing device 166 within the inner diameter 154 of the casing 152. The sensing device 166 is configured to detect some parameter within the casing such as temperature, pressure, fluid flow rate, or chemical content. In addition, a receiver-control circuit 50B is in electrical
20 communication with the sensing device 166 and is configured to emit electromagnetic signals 164 through an antenna 46B, which are representative of the parameters detected by the sensing device 166.

The sensing and monitoring system 160 also includes a transmitter device 50B configured to emit electromagnetic signals 140
25 to the antenna 46B, substantially as previously described. In addition, the transmitter device 50B is configured to receive the electromagnetic signals 164 generated by the receiver-control circuit 50B and transmitted through the antenna 46B. Further, the transmitter device 50B is in electrical communication with a control
30 panel 168 at the surface which is configured to display or store data detected by the sensing device 166. Alternately, the transmitter device 50B can be configured to store this data for subsequent retrieval.

Thus the invention provides a method and a system for
35 transmitting signals through a metal tubular. While the invention has been described with reference to certain preferred embodiments, as will be apparent to those skilled in the art, certain changes and modifications can be made without departing from the scope of the invention as defined by the following claims.

What is Claimed is:

1. A method for transmitting signals through a tubular comprising:
transmitting electromagnetic signals through a non-magnetic metal section in the tubular; and
selecting a material, a geometry, a treatment and an alloying of the non magnetic section to optimize the transmitting step.
2. The method of claim 1 wherein the tubular comprises a metal.
3. The method of claim 1 wherein the tubular is contained within a subterranean well.
4. The method of claim 1 further comprising detecting the electromagnetic signals during the transmitting step.
5. The method of claim 1 further comprising detecting a field produced by the electromagnetic signals during the transmitting step.
6. The method of claim 1 further comprising controlling or monitoring a device or an operation associated with the tubular responsive to the transmitting step.
7. The method of claim 1 wherein the non magnetic metal section comprises a tubular segment having an inside, a sidewall and an outside.
8. The method of claim 1 wherein the non magnetic metal section comprises a stainless steel tubular segment.
9. The method of claim 1 wherein the electromagnetic signals comprise an element selected from the group consisting of radio frequency (rf) signals, electric field signals, electromagnetic field signals and magnetic field signals.

10. A method for transmitting signals in a metal tubular having a non magnetic metal tubular section comprising:

transmitting electromagnetic signals from an inside of the non magnetic metal tubular section, through a sidewall of the non magnetic metal tubular section, to an antenna positioned on an outside of the non magnetic metal tubular section;

the antenna detecting the electromagnetic signals, or a secondary field associated with the electromagnetic signals.

11. The method of claim 10 further comprising controlling or monitoring a device or an operation associated with the metal tubular responsive to the detecting step.

12. The method of claim 10 further comprising transmitting electromagnetic signals from a sensing device associated with the metal tubular from the outside of the non magnetic metal tubular section, through the sidewall of the non magnetic tubular section.

13. The method of claim 10 wherein the non magnetic metal tubular section comprises austenitic stainless steel.

14. The method of claim 10 wherein the non magnetic metal tubular section comprises nitrogen strengthened austenitic stainless steel.

15. The method of claim 10 wherein the antenna comprises a wire coil mounted to the outside of the non magnetic metal tubular section.

16. The method of claim 10 wherein the signals comprise electromagnetic signals.

17. The method of claim 10 wherein the electromagnetic signals comprise a signal selected from the group consisting of radio frequency signals, electric field signals, electromagnetic field signals and magnetic field signals.

18. The method of claim 10 wherein the metal tubular is contained in a subterranean well.
19. The method of claim 18 wherein the method is used to improve production from the well.
20. A method for transmitting signals in a metal tubular having a non magnetic metal tubular section comprising:
 - moving a transmitter device configured to emit electromagnetic signals through the metal tubular and through the non magnetic metal tubular section;
 - emitting the electromagnetic signals during the moving step; and
 - detecting the electromagnetic signals, or a secondary field associated with the electromagnetic signals, using an antenna positioned proximate to the non magnetic metal tubular section.
21. The method of claim 20 further comprising controlling or monitoring a device or an operation associated with the metal tubular responsive to the detecting step.
22. The method of claim 20 further comprising transmitting signals through the non magnetic metal tubular section during the detecting step.
23. The method of claim 20 further comprising monitoring a sensor responsive to the detecting step.
24. The method of claim 20 wherein the non magnetic metal tubular section includes a y-block and the antenna is sealed in the y-block.
25. The method of claim 20 wherein the electromagnetic signals comprise modulated electromagnetic signals in a format selected from the group consisting of PSK (phase shift keying), FSK (frequency shift keying), ASK (amplitude shift keying), QPSK (quadrature

phase shift keying), QAM (quadrature amplitude modulation), and spread spectrum techniques.

26. The method of claim 20 wherein the moving step is performed using a wire line, a slick line, a parachute or a robot.

27. A signal transmission system comprising:
a metal tubular;
a non magnetic metal section on the metal tubular; and
an antenna outside the tubular proximate to the non magnetic metal section configured to receive electromagnetic signals transmitted through the non magnetic metal section.

28. The system of claim 27 wherein the non magnetic metal section comprises a tubular member.

29. The system of claim 27 wherein the non magnetic metal section comprises a stainless steel tubular member.

30. The system of claim 27 further comprising a transmitter device inside the metal tubular configured to emit the electromagnetic signals.

31. The system of claim 27 wherein the non magnetic metal section has an outside diameter and the antenna comprises a coiled wire on the outside diameter.

32. The system of claim 27 further comprising a receiver-control circuit outside of the metal tubular in electrical communication with the antenna configured to control or monitor a device or operation associated with the metal tubular.

33. The system of claim 27 wherein the metal tubular is contained in a subterranean well.

34. A signal transmission system comprising:
a metal tubular having a non magnetic metal section;
a transmitter device configured to move through the metal tubular and the non magnetic metal section and to emit electromagnetic signals through the non magnetic metal section; and
an antenna outside the non magnetic metal section configured to detect the electromagnetic signals or a secondary field associated with the electromagnetic signals.
35. The system of claim 34 wherein a material, a geometry, a treatment, and an alloying of the non magnetic metal section are selected to optimize signal transmission therethrough.
36. The system of claim 34 wherein the non magnetic metal section has a thickness T and the antenna has a length L selected to optimize signal transmission through the non magnetic metal section.
37. The system of claim 34 further comprising a control circuit outside of the metal tubular in signal communication with the antenna configured to control or monitor a device or operation associated with the metal tubular responsive to the electromagnetic signals.
38. The system of claim 34 further comprising a y-block on the non magnetic metal section configured to house and seal the antenna.
39. The system of claim 34 wherein the non magnetic metal section comprises stainless steel.
40. The system of claim 34 wherein the non magnetic metal section comprises nitrogen strengthened austenitic stainless steel.
41. A signal transmission system in a metal tubular comprising:
a transmitter device inside the metal tubular configured to emit electromagnetic

signals;

a non magnetic metal tubular section on the metal tubular configured to transmit the electromagnetic signals;

an antenna outside the metal tubular proximate to the non magnetic metal tubular section configured to receive the electromagnetic signals or a secondary field associated with the electromagnetic signals; and

a receiver-control circuit outside the metal tubular in electrical communication with the antenna configured to detect the electromagnetic signals or the secondary field, and to control or monitor a device or operation associated with the metal tubular.

42. The system of claim 41 wherein the device comprises a sensor device.

43. The system of claim 41 wherein the metal tubular comprises a component of an oil and gas well.

44. The system of claim 41 wherein the non magnetic metal tubular section comprises austenitic stainless steel.

45. The system of claim 41 wherein the non magnetic metal tubular section comprises nitrogen strengthened austenitic stainless steel.

46. The system of claim 41 wherein the electromagnetic signals comprise modulated electromagnetic signals selected from the group consisting of radio frequency (rf) signals, electric field signals, electromagnetic field signals and magnetic field signals.

47. A signal transmission system in a metal tubular comprising:

a non magnetic metal tubular section on the metal tubular having a sidewall;

an antenna proximate to the non magnetic metal tubular section;

a transmitter device inside the metal tubular configured to transmit electromagnetic signals through the sidewall of the non magnetic metal tubular section to the antenna; and

a circuit in signal communication with the antenna configured to detect, amplify, filter

and tune the electromagnetic signals, or a secondary field associated with the electromagnetic signals.

48. The system of claim 47 wherein the antenna comprises a generally cylindrical non conductive core mounted to an outside diameter of the non magnetic metal tubular section, and a metal wire wrapped around the core.

49. The system of claim 47 further comprising a y-block on the non magnetic metal tubular section configured to seal the antenna and house the circuit.

50. The system of claim 47 wherein the electromagnetic signals comprise modulated electromagnetic signals in a format selected from the group consisting of PSK (phase shift keying), FSK (frequency shift keying), ASK (amplitude shift keying), QPSK (quadrature phase shift keying), QAM (quadrature amplitude modulation), and spread spectrum techniques.

51. The system of claim 47 further comprising a device outside of the metal tubular in signal communication with the circuit, and wherein the circuit is configured to transmit control signals to the device.

52. The system of claim 47 further comprising a sensing device outside of the metal tubular in signal communication with the circuit configured to detect a parameter, and wherein the circuit is configured to transmit signals representative of the parameter through the non magnetic metal tubular section.

53. The system of claim 47 wherein the transmitter device includes a housing, a coil in the housing and an oscillator in signal communication with the coil.

54. A method for improving production in an oil and gas well having a metal tubular with a non magnetic metal section comprising:

moving a transmitter device through the metal tubular and the non magnetic metal

section while emitting electromagnetic signals therefrom;

transmitting the electromagnetic signals through the non magnetic metal section;

detecting the electromagnetic signals transmitted through the non magnetic metal section; and

controlling or monitoring a device or an operation associated with the well responsive to the detecting step.

55. The method of claim 54 wherein the detecting step is performed using an antenna outside of the non magnetic metal section configured to detect the electromagnetic signals or a secondary field associated with the electromagnetic signals.

56. The method of claim 54 wherein the non magnetic metal section comprises a stainless steel tubular segment.

57. The method of claim 54 wherein the device comprise an element selected from the group consisting of perforating devices, packer devices, valves, sleeves, sensors, fluid analysis sensors, formation sensors and control devices.

58. The method of claim 54 wherein the antenna is located in a first zone of the well and the device is located in a second zone of the well.

59. A method for transmitting signals in a metal tubular having a non magnetic metal tubular section comprising:

moving a transmitter device configured to emit electromagnetic signals through the metal tubular and through the non magnetic metal tubular section;

emitting the electromagnetic signals during the moving step;

detecting the electromagnetic signals, or a secondary field associated with the electromagnetic signals, using an antenna positioned proximate to the non magnetic metal tubular section; and

detonating a perforating device responsive to the detecting step.

60. A method for transmitting signals in a metal tubular having a non magnetic metal tubular section comprising:

moving a transmitter device configured to emit electromagnetic signals through the metal tubular and through the non magnetic metal tubular section;

emitting the electromagnetic signals during the moving step;

detecting the electromagnetic signals, or a secondary field associated with the electromagnetic signals, using an antenna positioned proximate to the non magnetic metal tubular section; and

actuating a packer device responsive to the detecting step.

61. A method for transmitting signals in a metal tubular contained in a subterranean well and having a non magnetic metal tubular section comprising:

moving a transmitter device configured to emit electromagnetic signals through the metal tubular and through the non magnetic metal tubular section;

emitting the electromagnetic signals during the moving step;

detecting the electromagnetic signals, or a secondary field associated with the electromagnetic signals, using an antenna positioned proximate to the non magnetic metal tubular section, said detecting step being used to improve production from the well.

62. A signal transmission system in a metal tubular comprising:

a transmitter device inside the metal tubular configured to emit electromagnetic signals;

a non magnetic metal tubular section on the metal tubular configured to transmit the electromagnetic signals;

a non magnetic metal tubular section on the metal tubular configured to transmit the electromagnetic signals;

an antenna outside the metal tubular proximate to the non magnetic metal tubular section configured to receive the electromagnetic signals or a secondary field associated with the electromagnetic signals; and

a receiver-control circuit outside the metal tubular in electrical communication with the antenna configured to detect the electromagnetic signals or the secondary field, and to control or monitor a perforating device or operation associated with the metal tubular.

63. A signal transmission system in a metal tubular comprising:
- a transmitter device inside the metal tubular configured to emit electromagnetic signals;
 - a non magnetic metal tubular section on the metal tubular configured to transmit the electromagnetic signals;
 - a non magnetic metal tubular section on the metal tubular configured to transmit the electromagnetic signals;
 - an antenna outside the metal tubular proximate to the non magnetic metal tubular section configured to receive the electromagnetic signals or a secondary field associated with the electromagnetic signals; and
 - a receiver-control circuit outside the metal tubular in electrical communication with the antenna configured to detect the electromagnetic signals or the secondary field, and to control or monitor a packer device or operation associated with the metal tubular.
64. A method for transmitting signals in a subterranean well having a metal tubular with a non magnetic metal section comprising:
- moving a transmitter device through the metal tubular and the non magnetic metal section while emitting electromagnetic signals therefrom; and
 - controlling or monitoring a device or an operation associated with the well responsive to the detecting the electromagnetic signals that are transmitted through the non magnetic metal section.

1/10

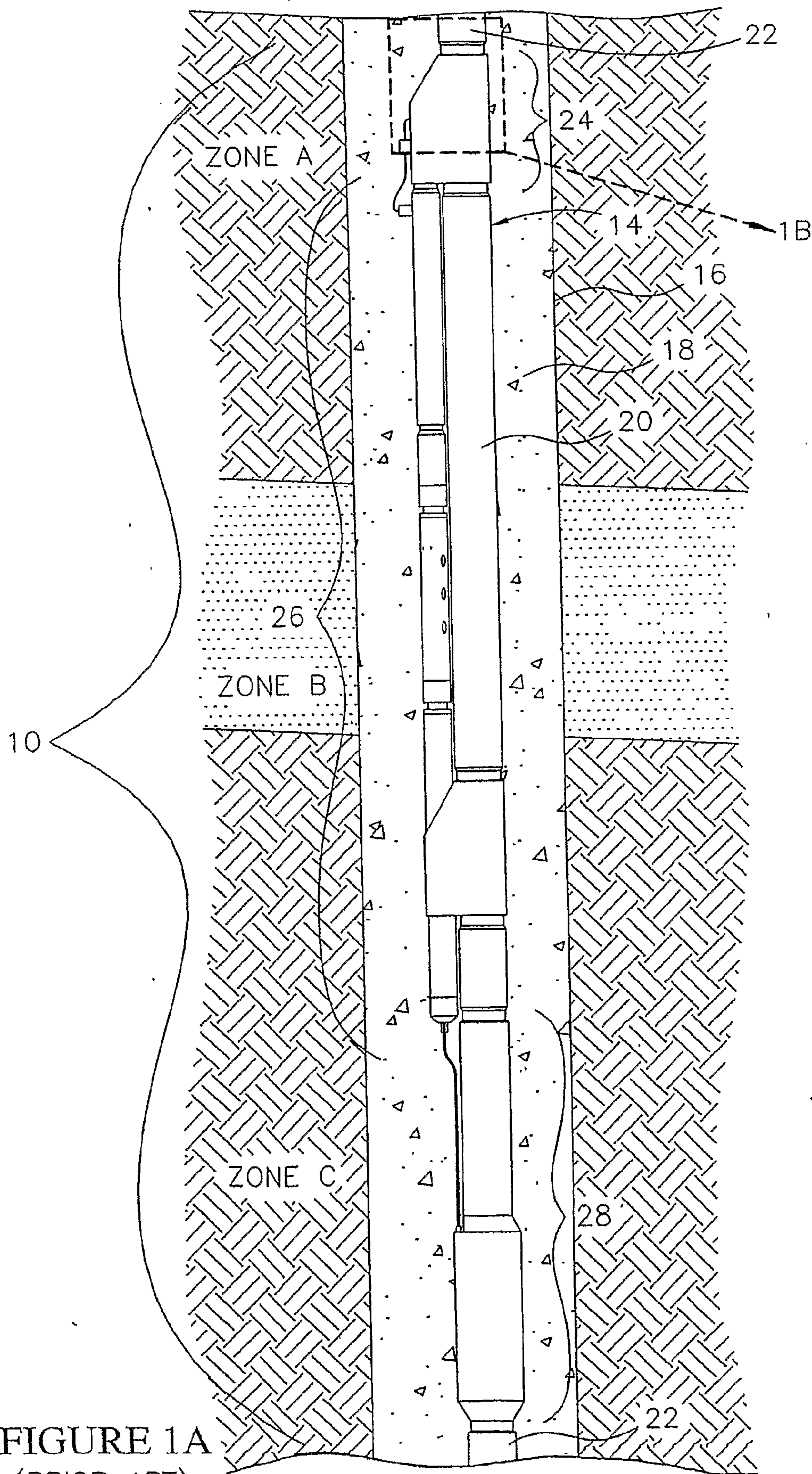

FIGURE 1A
(PRIOR ART)

2/10

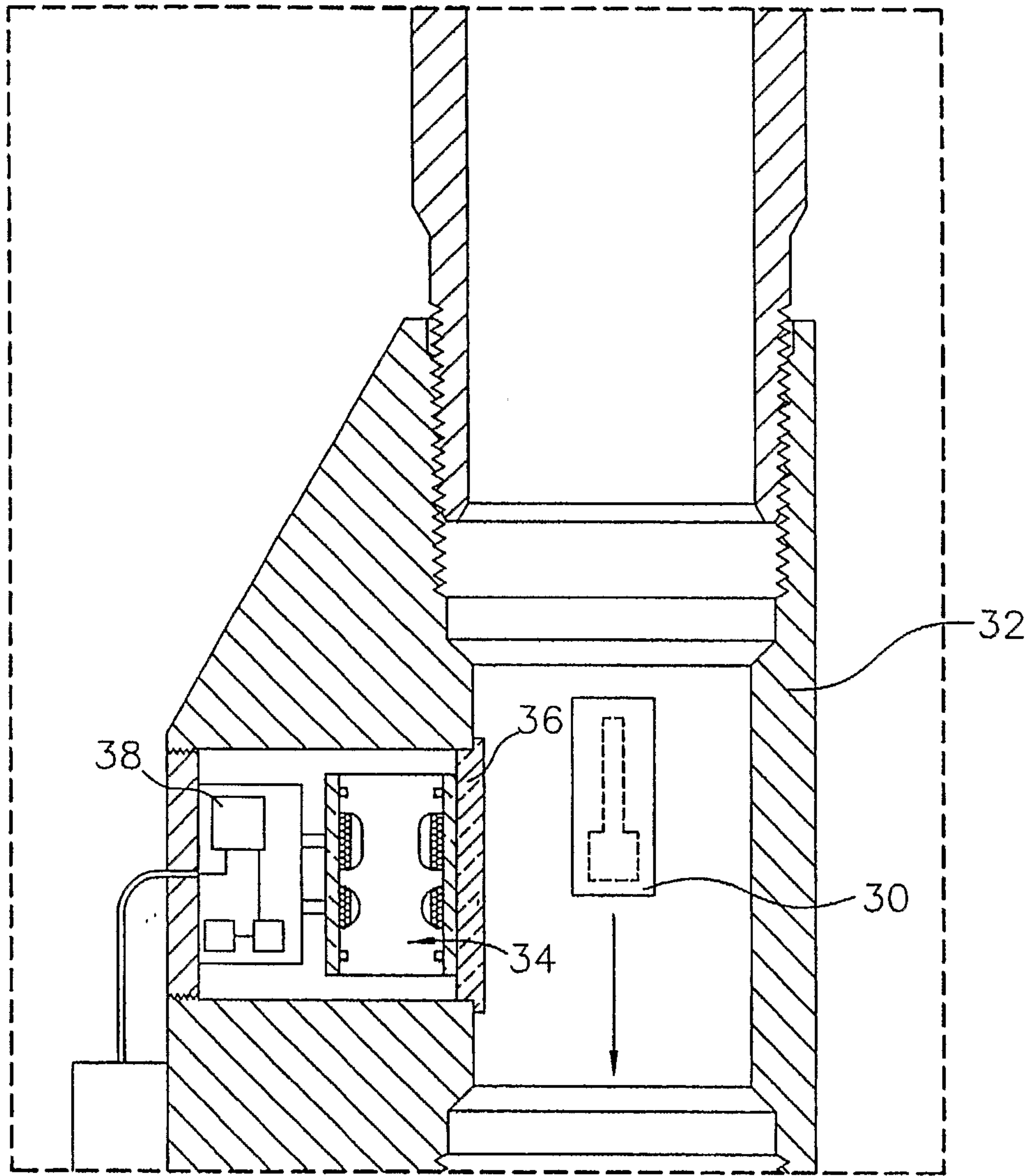

FIGURE 1B
(PRIOR ART)

3/10

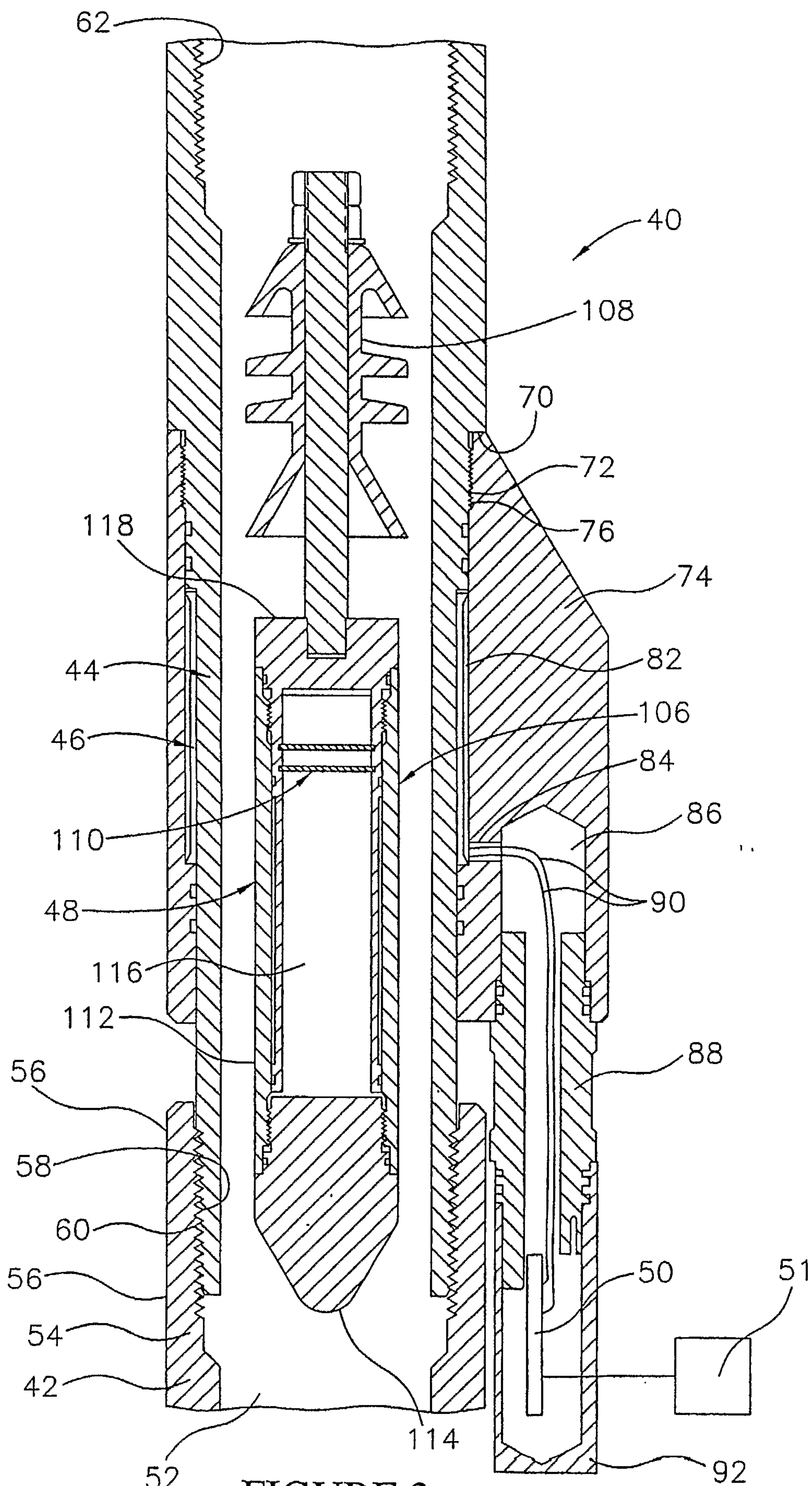

FIGURE 2

SUBSTITUTE SHEET (RULE 26)

4/10

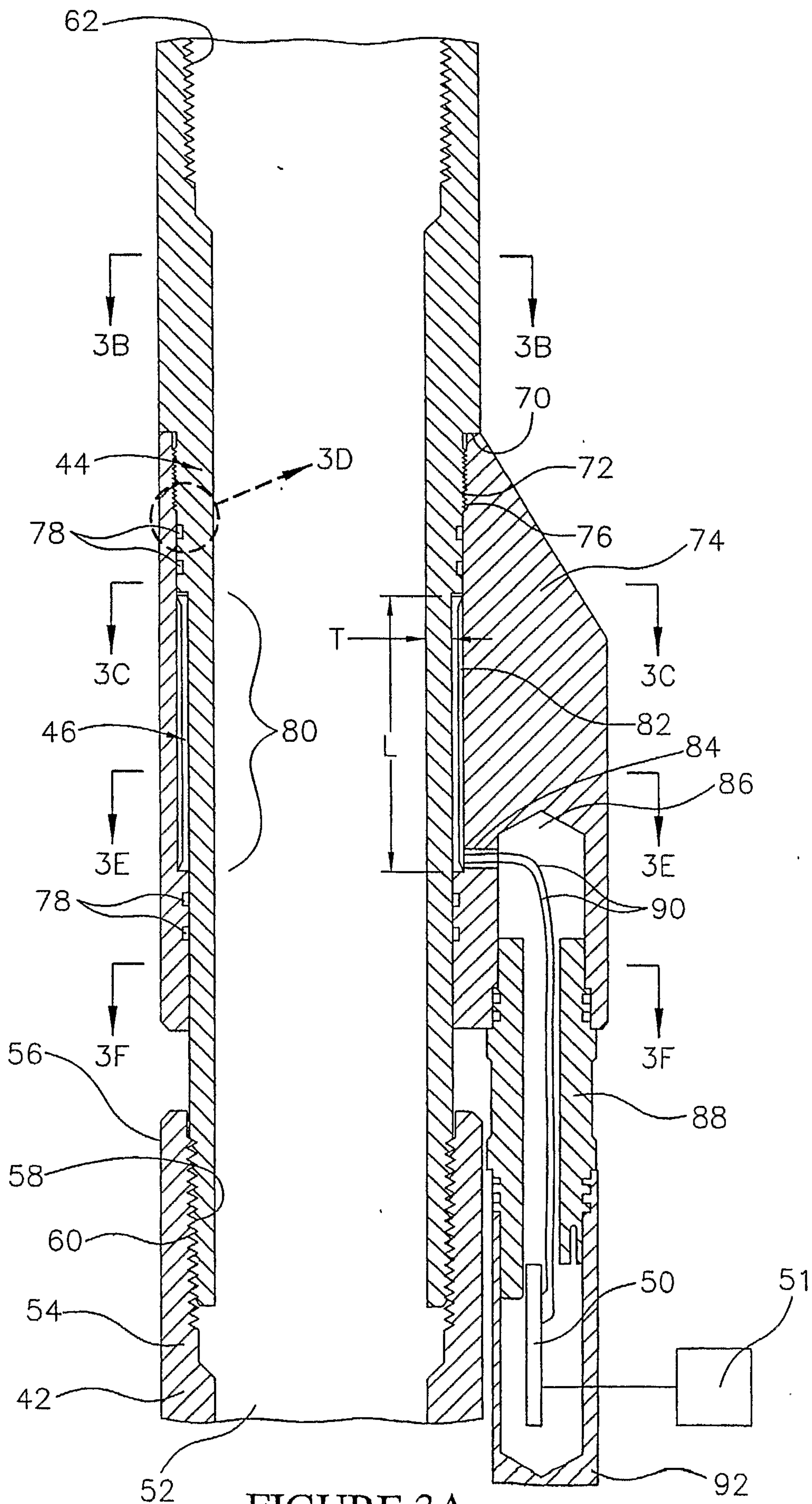

FIGURE 3A

SUBSTITUTE SHEET (RULE 26)

5/10

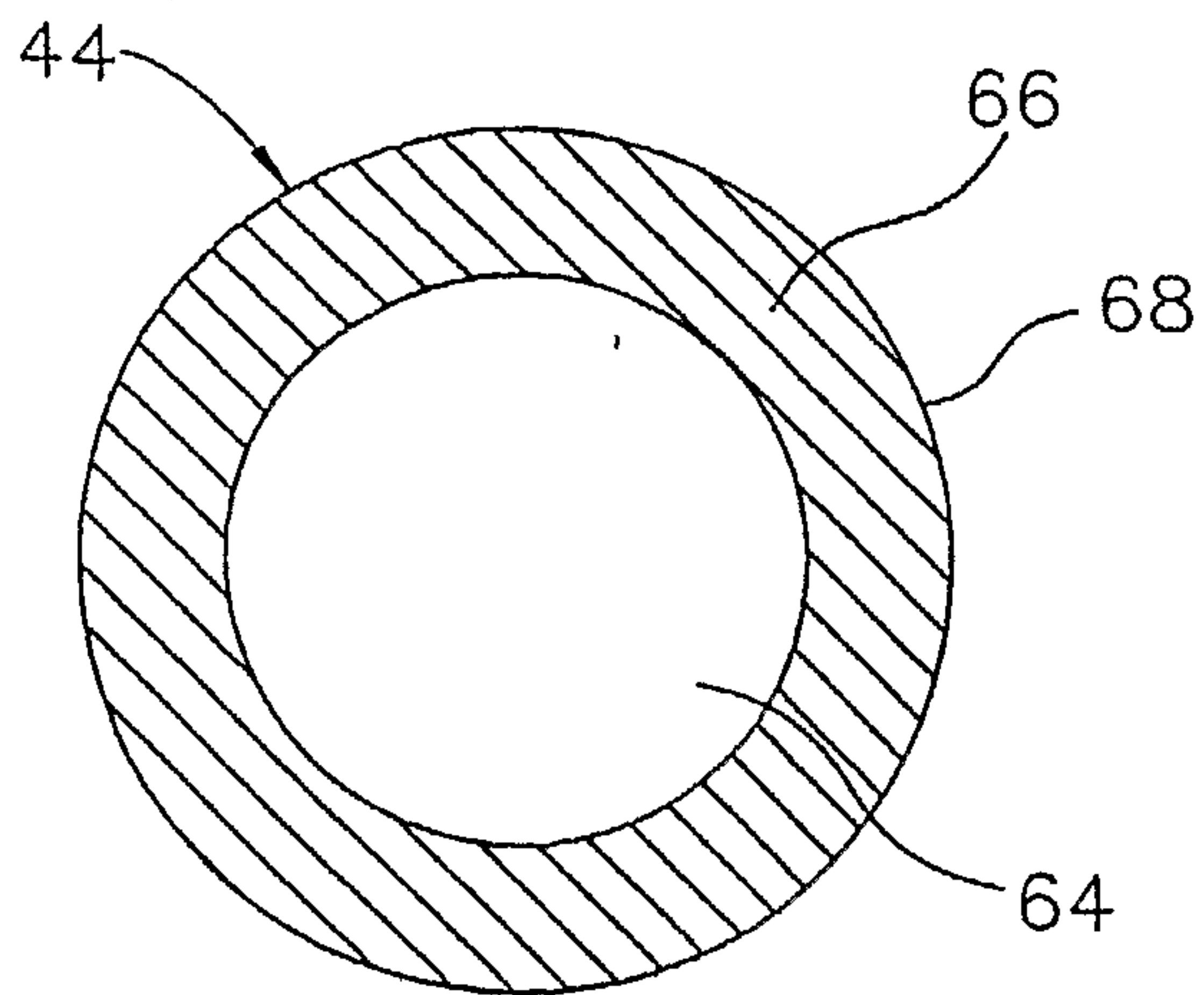

FIGURE 3B

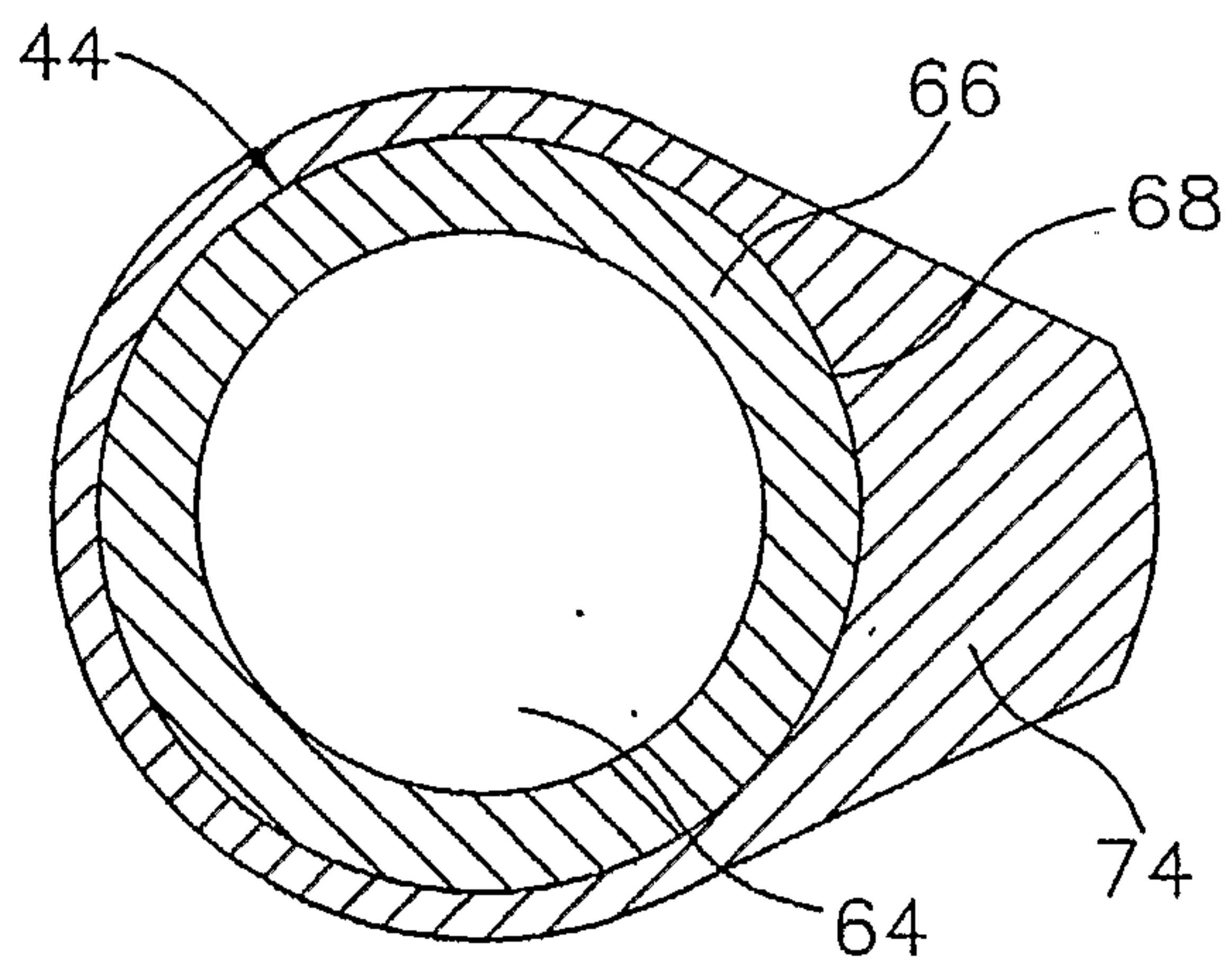

FIGURE 3C

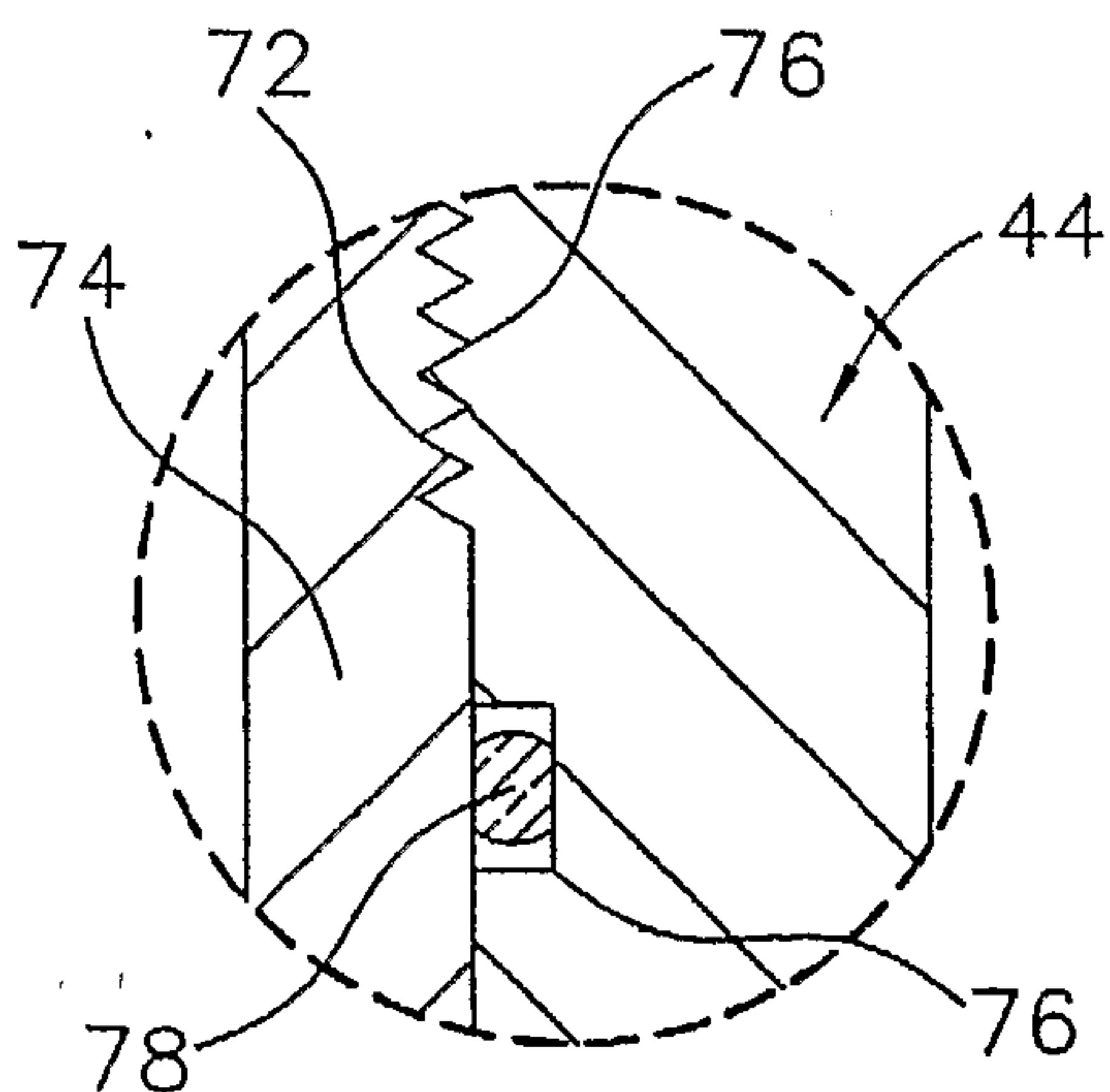

FIGURE 3D

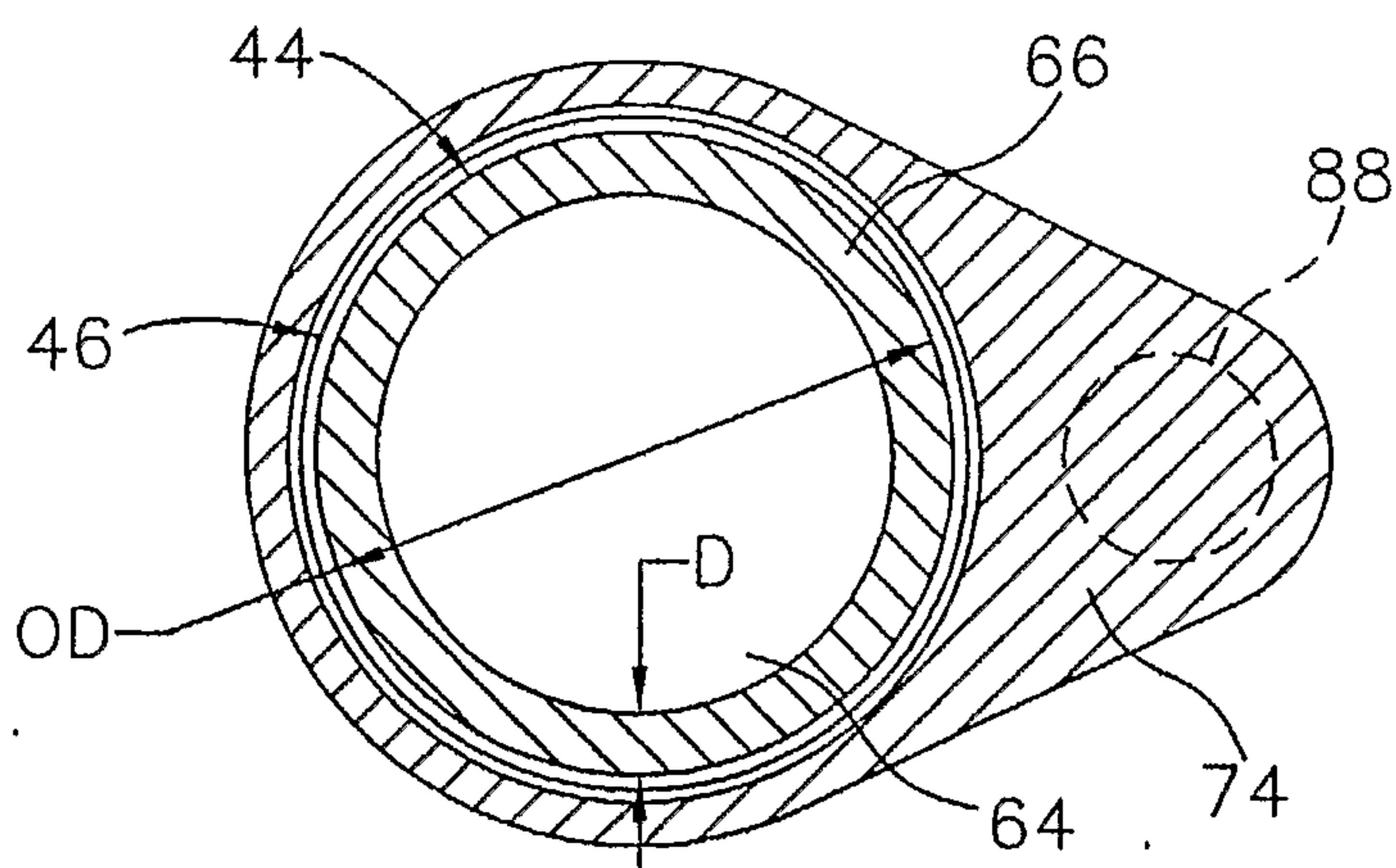

FIGURE 3E

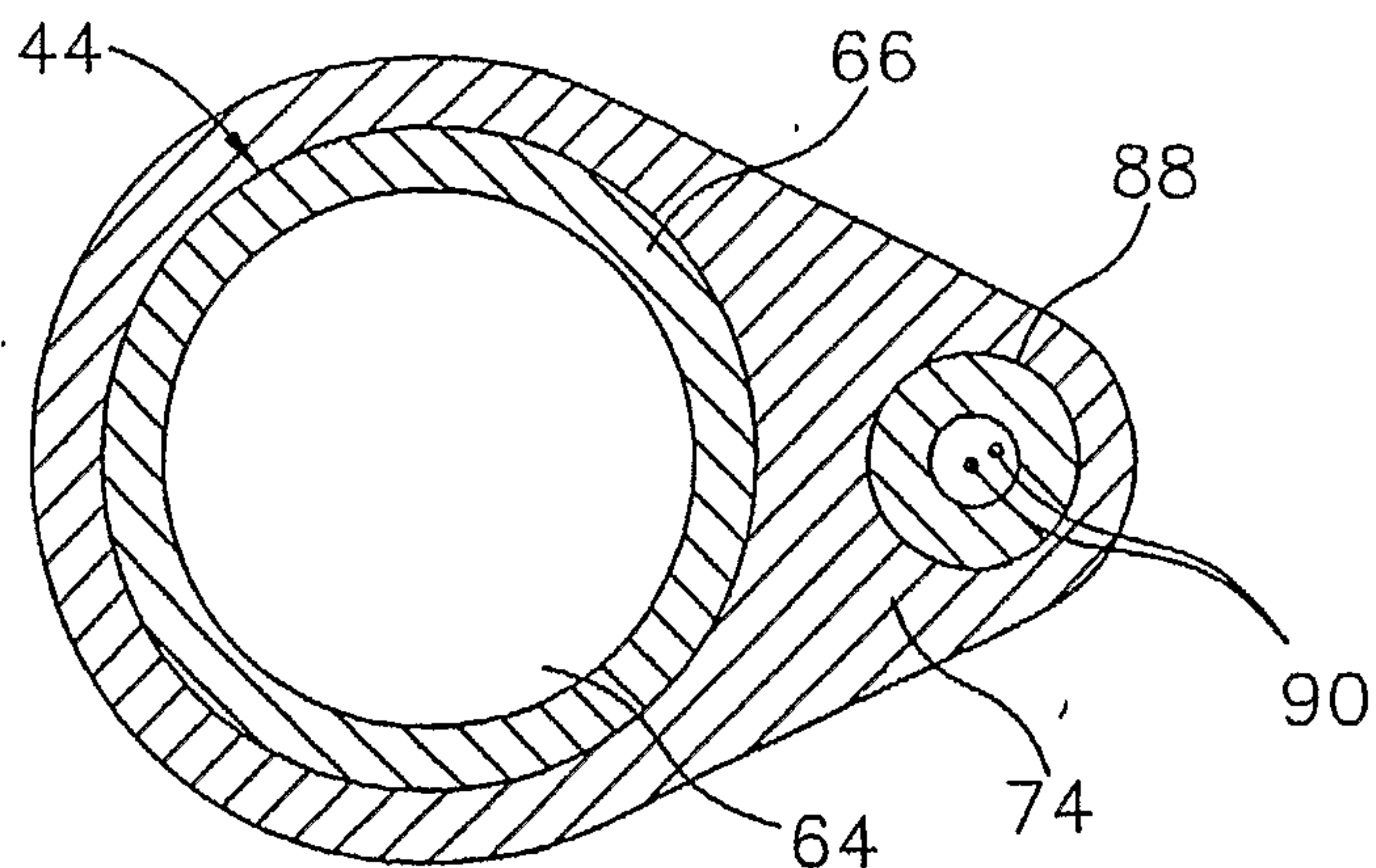

FIGURE 3F

6/10

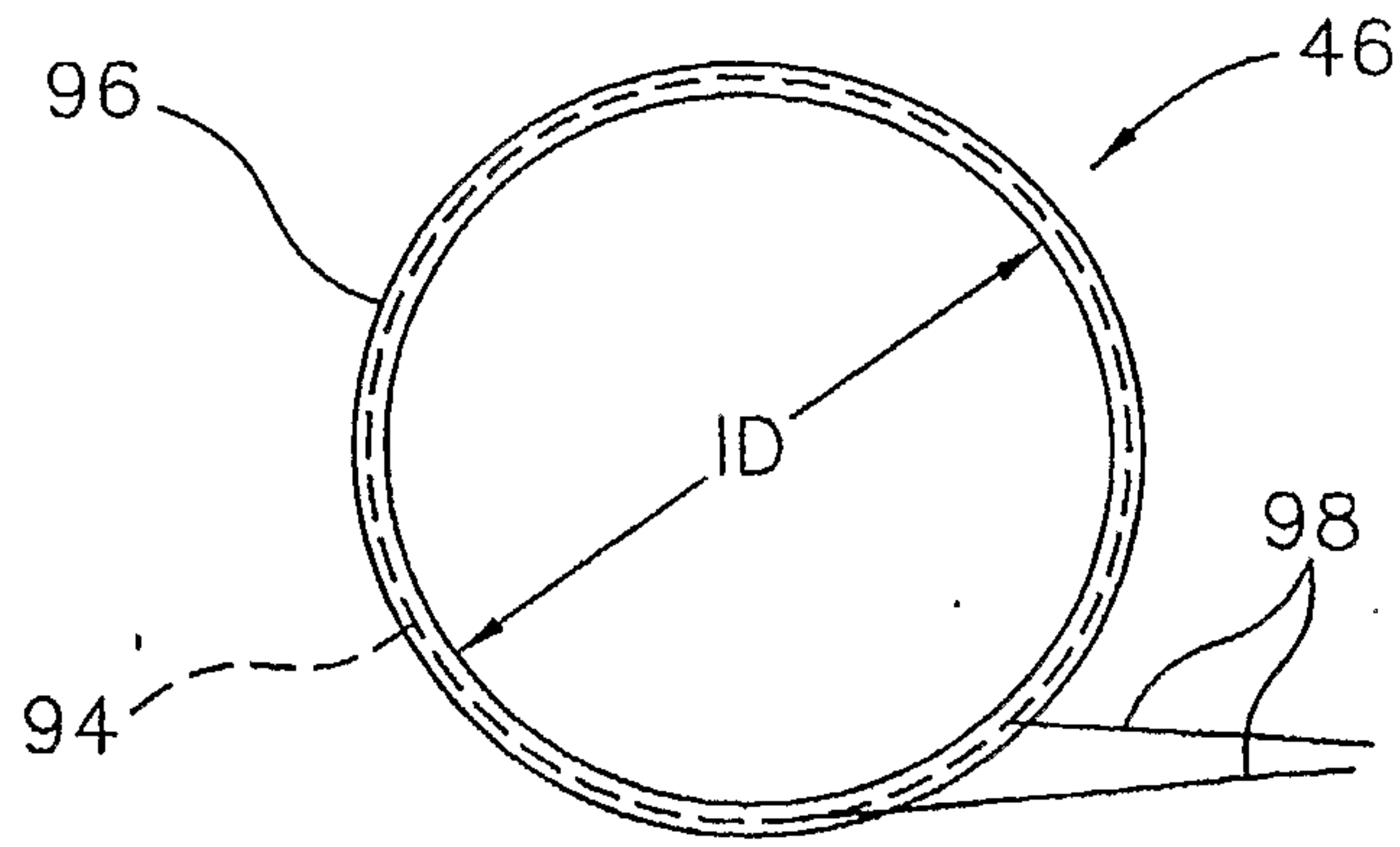

FIGURE 4A

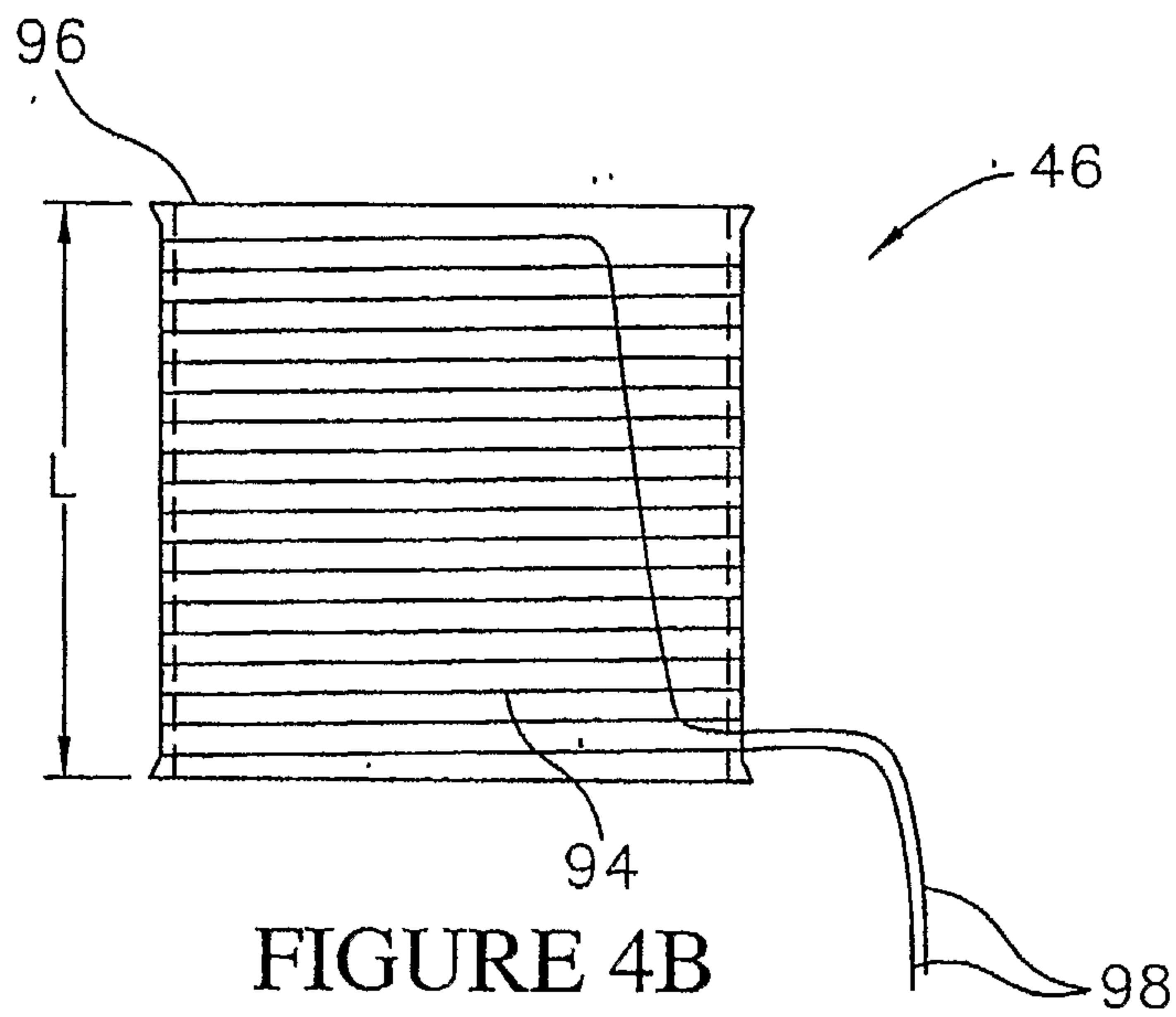

FIGURE 4B

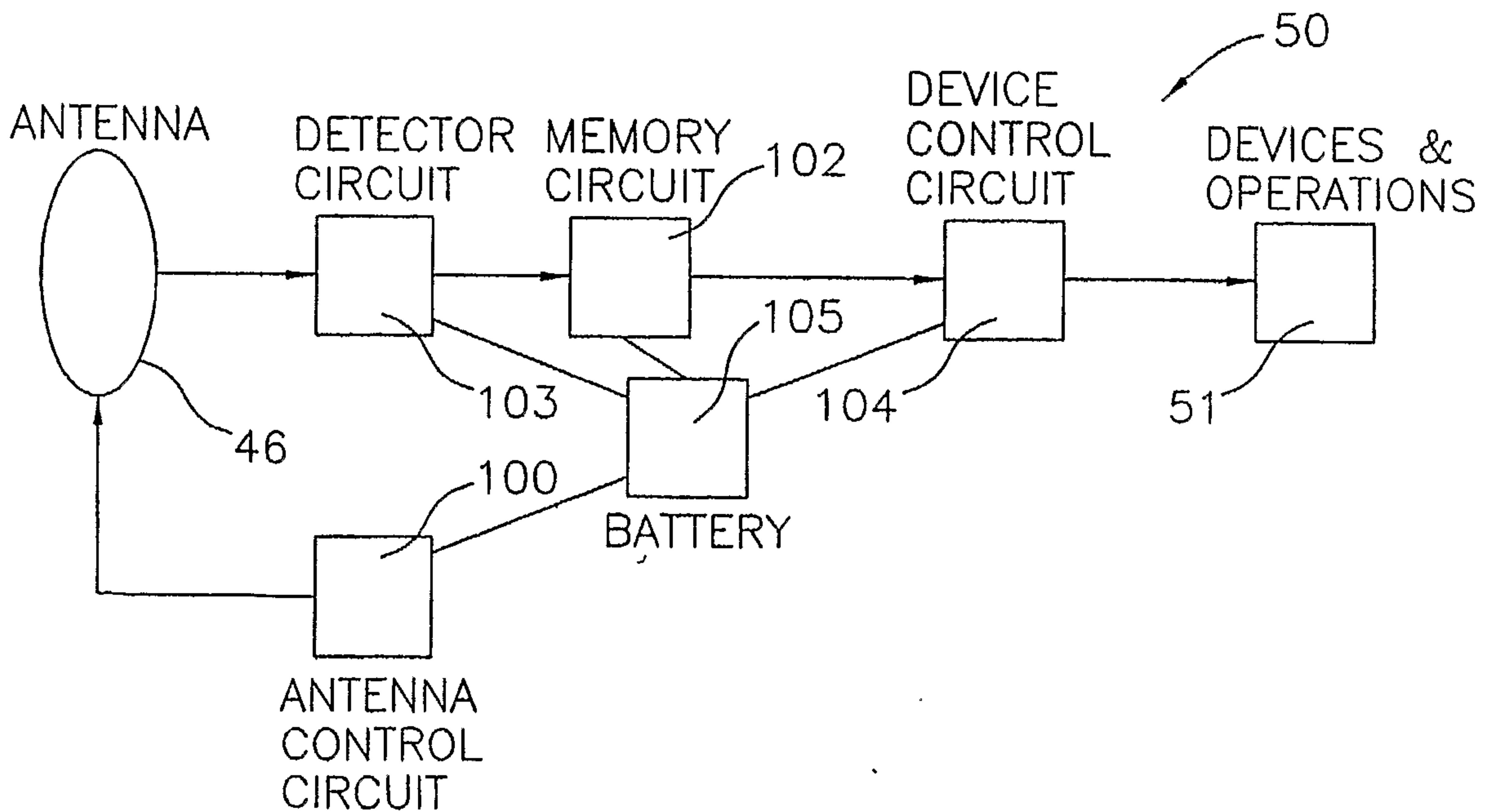

FIGURE 5

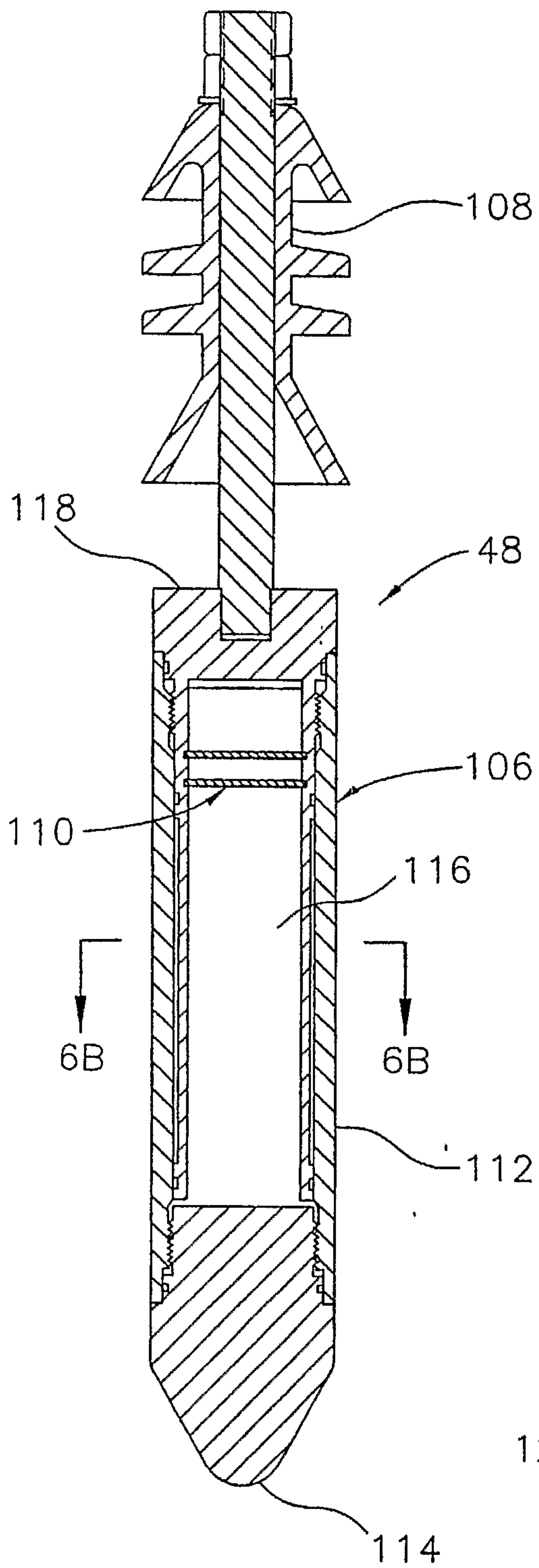

FIGURE 6A

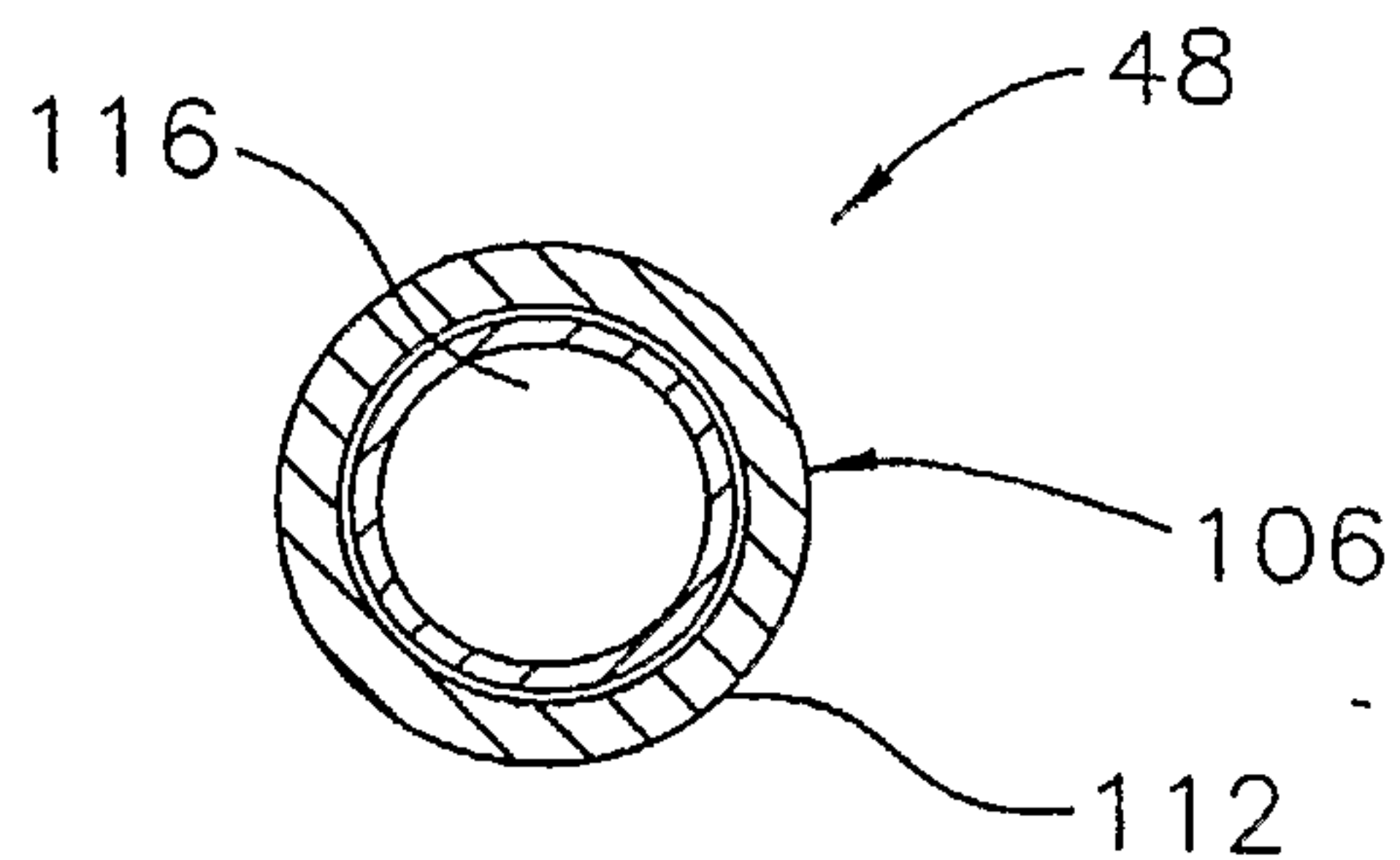

FIGURE 6B

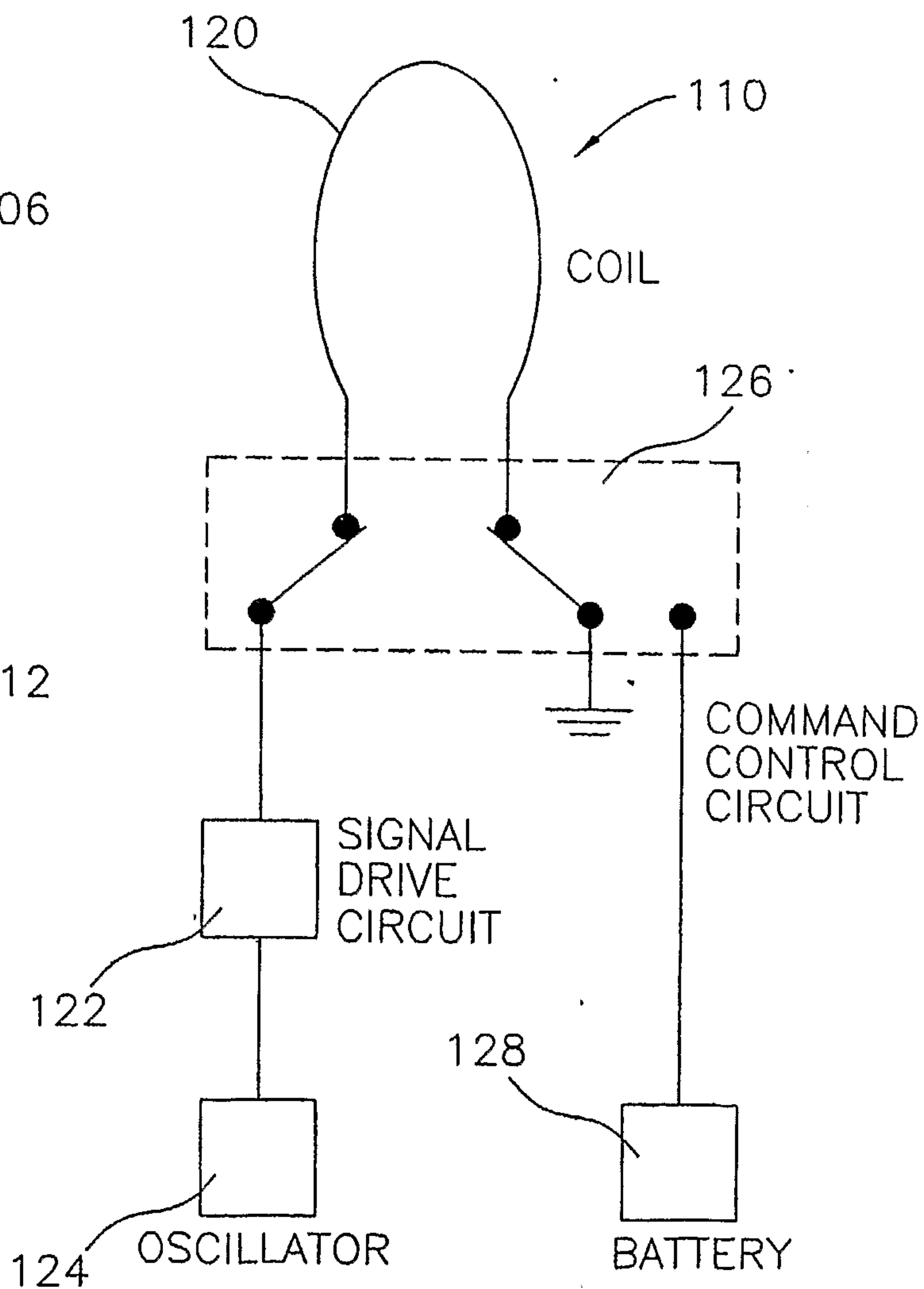

FIGURE 6C

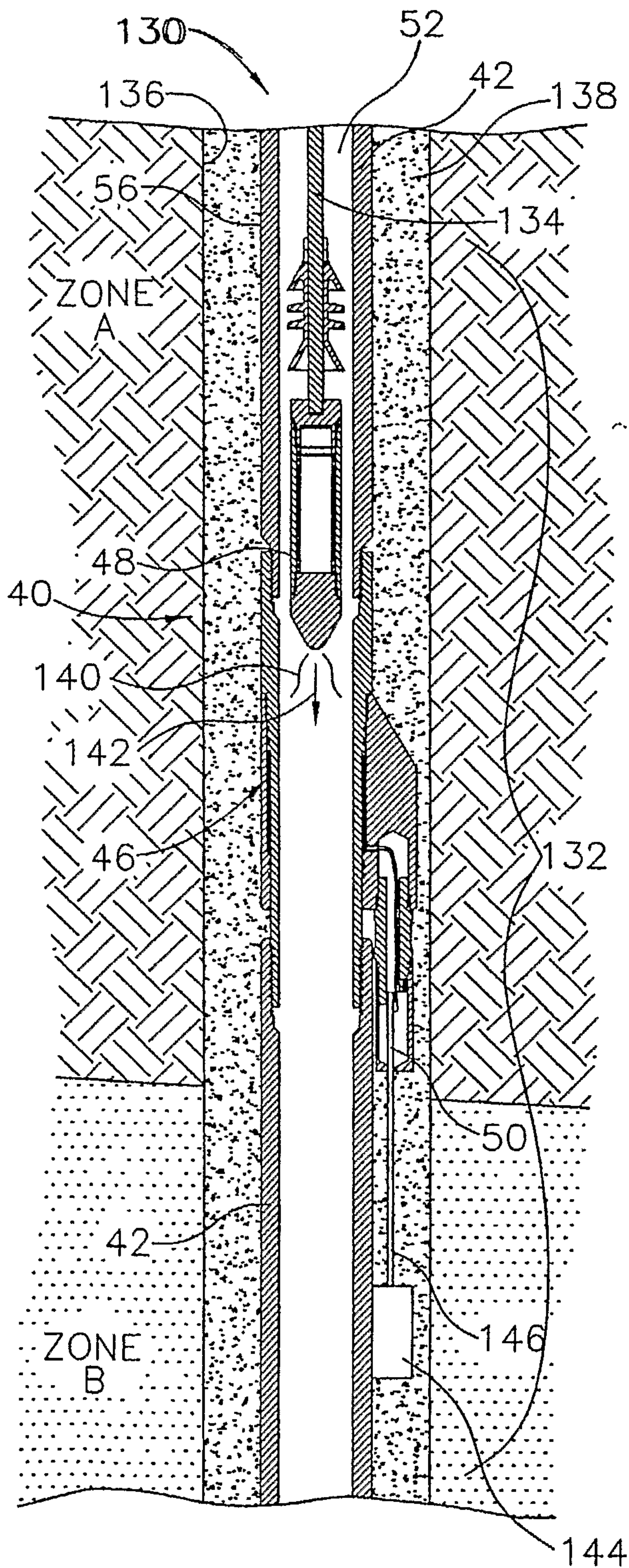

FIGURE 7A

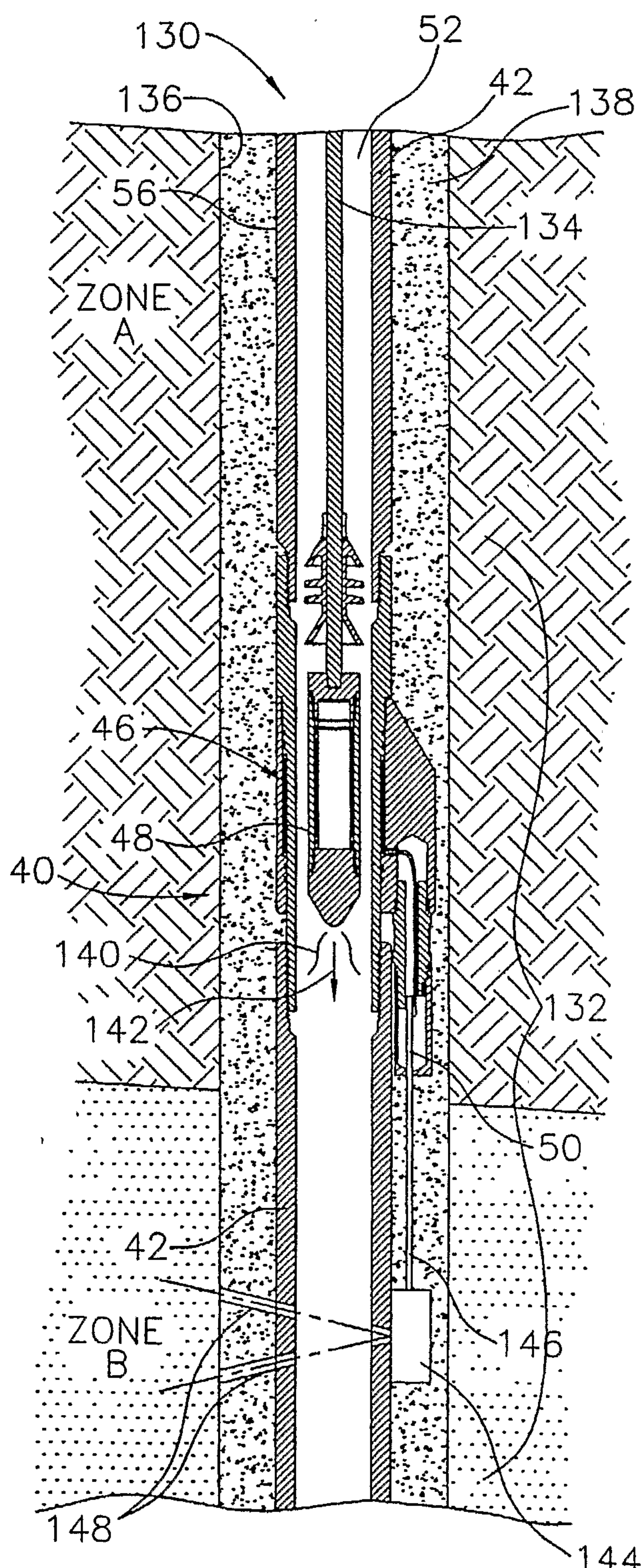

FIGURE 7B

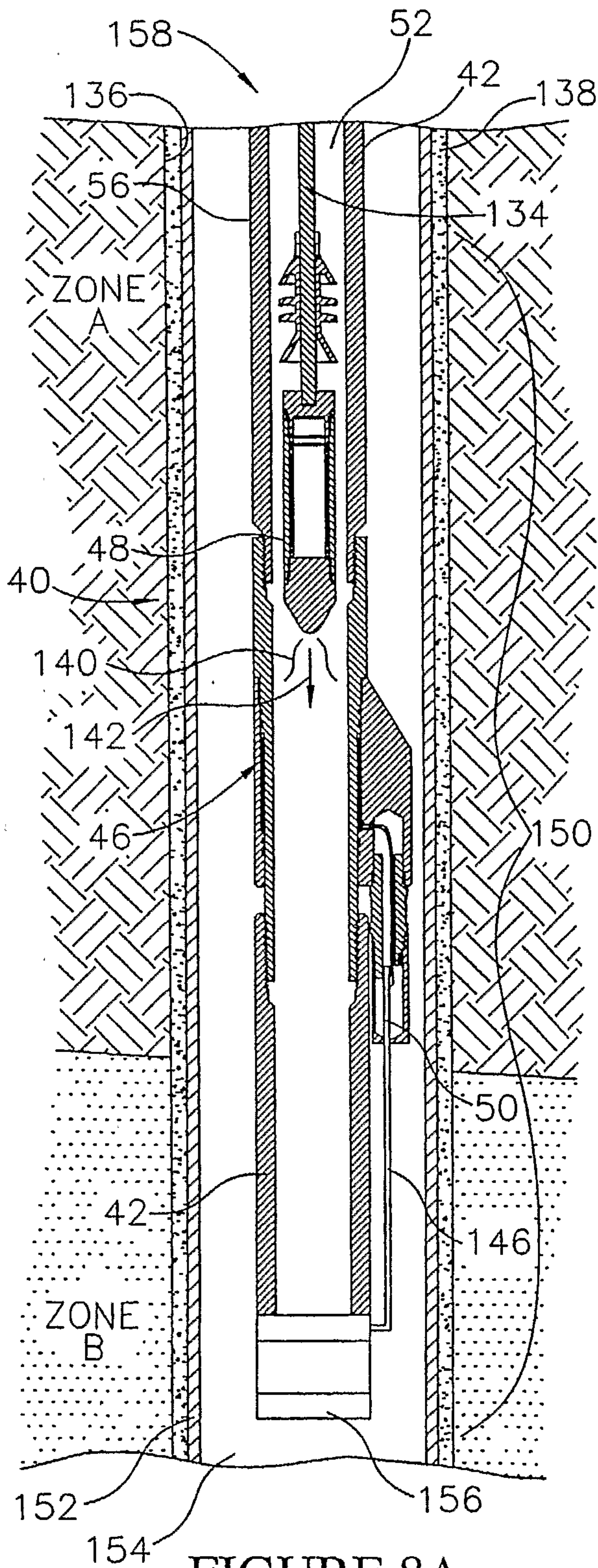

FIGURE 8A

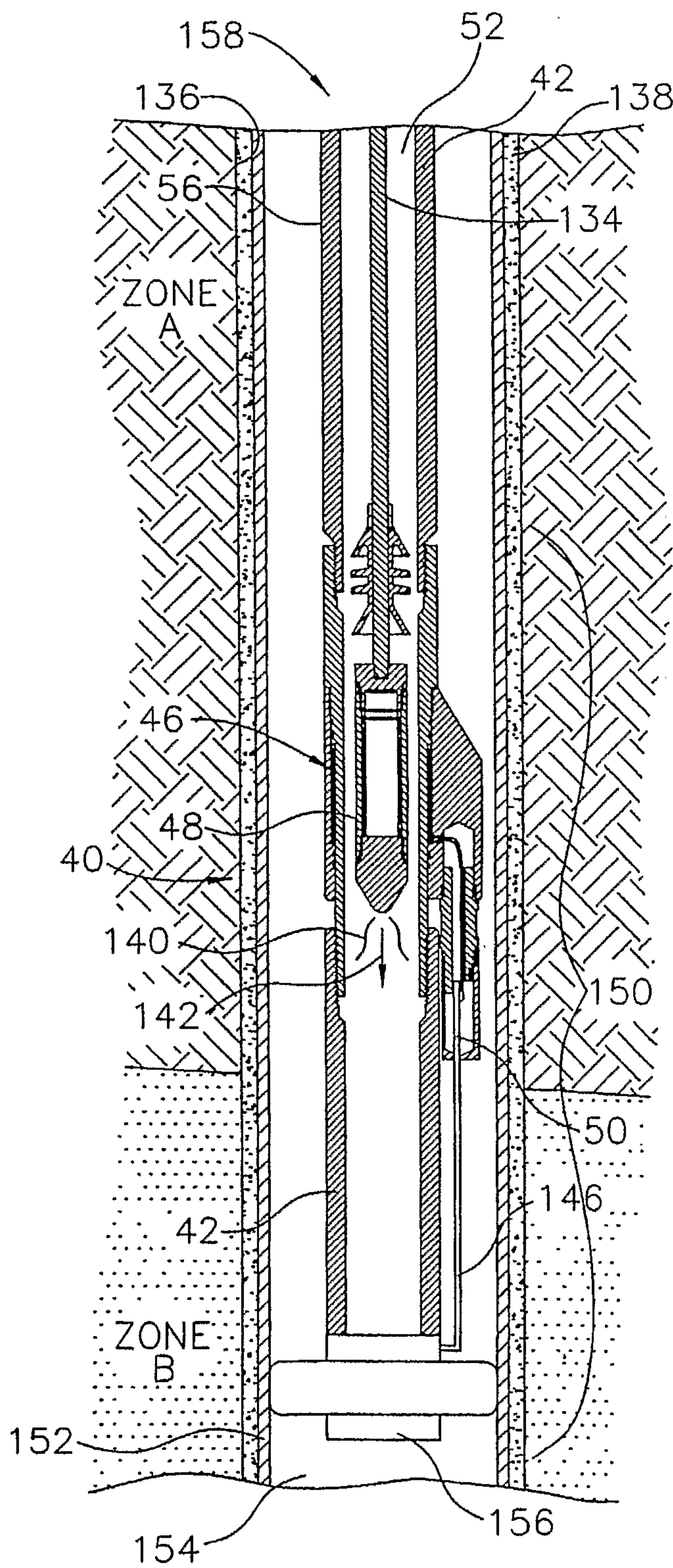

FIGURE 8B

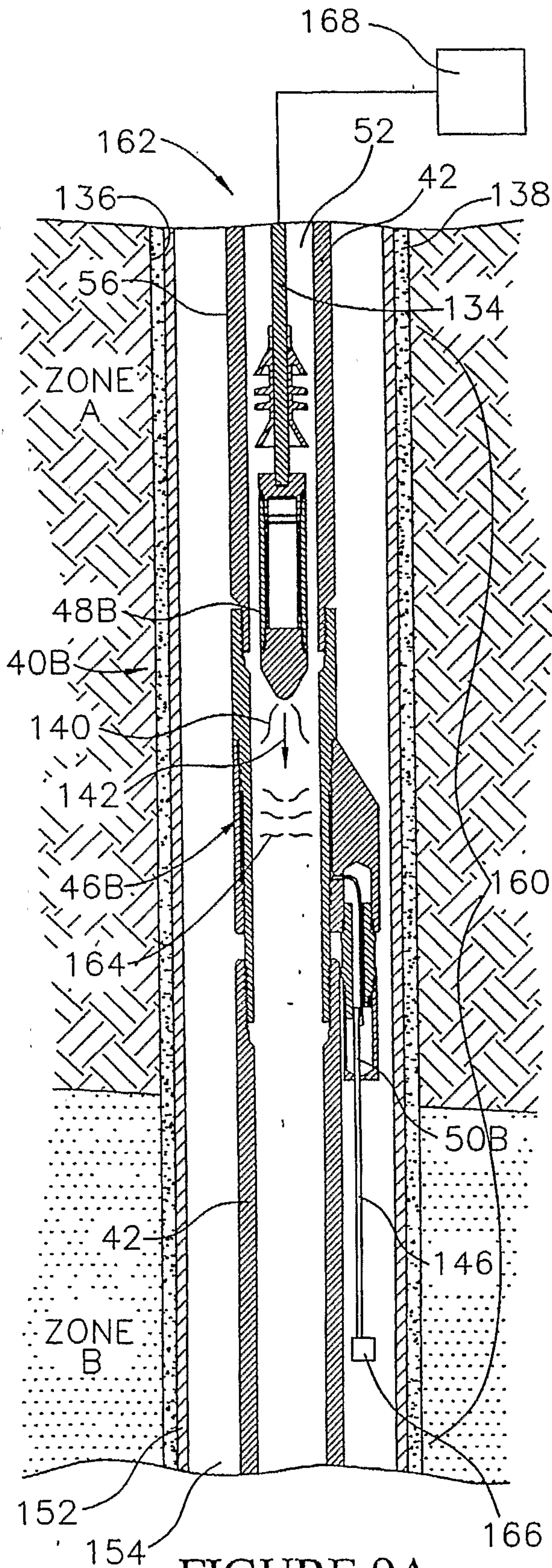

FIGURE 9A

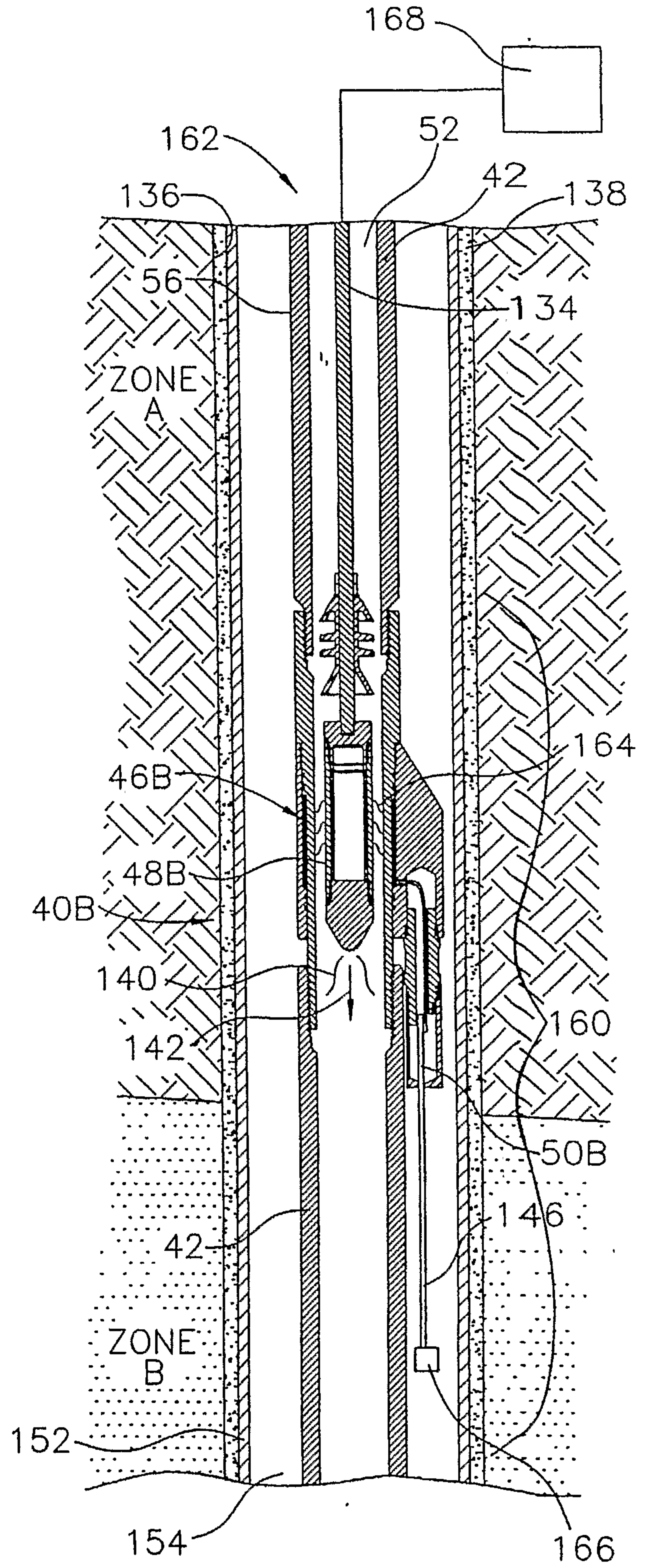

FIGURE 9B

