

(19) World Intellectual Property
Organization
International Bureau



(43) International Publication Date
29 December 2004 (29.12.2004)

PCT

(10) International Publication Number
WO 2004/113902 A1

(51) International Patent Classification⁷: **G01N 27/30**,
C12Q 1/00

(21) International Application Number:
PCT/US2004/019687

(22) International Filing Date: 18 June 2004 (18.06.2004)

(25) Filing Language: English

(26) Publication Language: English

(30) Priority Data:
60/480,397 20 June 2003 (20.06.2003) US

(71) Applicant (for DE only): **ROCHE DIAGNOSTICS
GMBH** [DE/DE]; Sandhofer Strasse 116, D-68298
Mannheim (DE).

(71) Applicant (for all designated States except DE, US): **F.
HOFFMANN-LA ROCHE AG** [CH/CH]; Grenzacher-
strasse 124, CH-4070 Basel (CH).

(72) Inventors; and

(75) Inventors/Applicants (for US only): **BURKE, David, W.**
[US/US]; 8951 Riverbend Court, Carmel, IN 46250 (US).
MARQUANT, Michael [DE/DE]; Ida-Dehmel-Ring

84, D-68309 Mannheim (DE). **ZAPF, Udo** [DE/DE];
Ludwigstrasse 36, 67346 Speyer (DE). **FRITZ, Michael**
[DE/DE]; Gross-Rohrheimer-Strasse 19, 68647 Biblis
(DE). **MOSOIU, Dan** [DE/DE]; Albert Einstein Allee 33,
67117 Limburgerhoff (DE). **WILSEY, Christopher, D.**
[US/US]; 516 Oak Drive, Carmel, IN 46032 (US).

(74) Agents: **BARTOL, Michael, C.** et al.; Woodard, Emhardt,
Moriarty, Mcnett & Henry LLP, Bank One Center/Tower,
Suite 3700, 111 Monument Circle, Indianapolis, IN 46204
(US).

(81) Designated States (unless otherwise indicated, for every
kind of national protection available): AE, AG, AL, AM,
AT, AU, AZ, BA, BB, BG, BR, BW, BY, BZ, CA, CH, CN,
CO, CR, CU, CZ, DE, DK, DM, DZ, EC, EE, EG, ES, FI,
GB, GD, GE, GH, GM, HR, HU, ID, IL, IN, IS, JP, KE,
KG, KP, KR, KZ, LC, LK, LR, LS, LT, LU, LV, MA, MD,
MG, MK, MN, MW, MX, MZ, NA, NI, NO, NZ, OM, PG,
PH, PL, PT, RO, RU, SC, SD, SE, SG, SK, SL, SY, TJ, TM,
TN, TR, TT, TZ, UA, UG, US, UZ, VC, VN, YU, ZA, ZM,
ZW.

(84) Designated States (unless otherwise indicated, for every
kind of regional protection available): ARIPO (BW, GH,

[Continued on next page]

(54) Title: REAGENT STRIPE FOR TEST STRIP

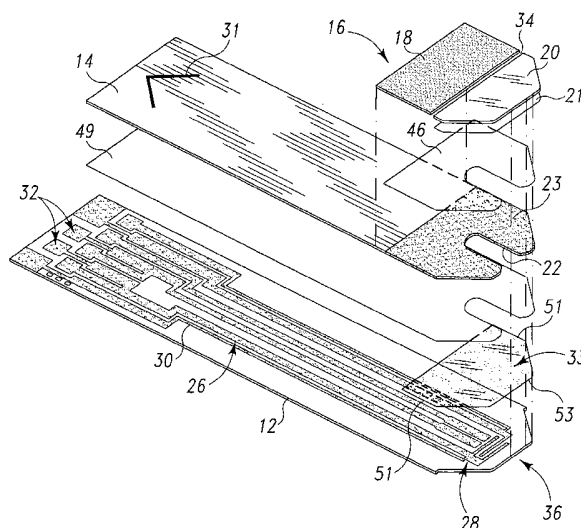

(57) Abstract: A test strip (10) having a small sample-receiving chamber on the order of less than 1 microliter includes a reagent layer (33) that extends across the width of the test strip and also extends to the sample-receiving end (36), such that the edges of the reagent layer are aligned with the side and dose receiving edges of the test strip. The hydrophilic reagent extending to the dosing edge of the strip promotes wicking of the sample into the test strip. The end and side edges of the reagent layer are preferably formed as part of a cutting process that forms individual test strips from a larger web, which results in a smooth and thin reagent layer with a uniform thickness, substantially covering the entire floor of the sample-receiving chamber. The inventive mass production process helps improve the reproducibility of the quantity, location, thickness and other properties of the reagent layer, which in turn improves the accuracy of the test result.

WO 2004/113902 A1



GM, KE, LS, MW, MZ, NA, SD, SL, SZ, TZ, UG, ZM, ZW), Eurasian (AM, AZ, BY, KG, KZ, MD, RU, TJ, TM), European (AT, BE, BG, CH, CY, CZ, DE, DK, EE, ES, FI, FR, GB, GR, HU, IE, IT, LU, MC, NL, PL, PT, RO, SE, SI, SK, TR), OAPI (BF, BJ, CF, CG, CI, CM, GA, GN, GQ, GW, ML, MR, NE, SN, TD, TG).

— *before the expiration of the time limit for amending the claims and to be republished in the event of receipt of amendments*

Published:

— *with international search report*

For two-letter codes and other abbreviations, refer to the "Guidance Notes on Codes and Abbreviations" appearing at the beginning of each regular issue of the PCT Gazette.

REAGENT STRIPE FOR TEST STRIP

RELATED APPLICATIONS

5 This application claims priority to U.S. Provisional Patent Application Serial
No. 60/480,397, filed June 20, 2003. This application is related to a commonly
assigned application entitled "Method and Reagent for Producing Narrow,
Homogeneous Reagent Stripes" (hereinafter "Homogeneous Reagent Stripes
application"), filed on even date herewith and incorporated herein by reference in its
10 entirety.

FIELD OF THE INVENTION

 The present invention relates generally to the testing of body fluids for
15 concentration of analytes and more particularly to a test strip or biosensor for such
testing.

BACKGROUND

 Test strips are often used to measure the presence and/or concentrations of
20 selected analytes in test samples. For example, a variety of test strips are used to
measure glucose concentrations in blood to monitor the blood sugar level of people
with diabetes. These test strips include a reaction chamber into which a reagent
composition has been deposited. Current trends in test strips require smaller test
samples and faster analysis times. This provides a significant benefit to the patient,
25 allowing the use of smaller blood samples that can be obtained from less sensitive
areas of the body. Additionally, faster test times and more accurate results enable
patients to better control their blood sugar level.

 In connection with smaller sample volumes, it is known to provide test strips
having a sufficiently small reaction chamber such that sample fluid is drawn therein
30 by capillary action, which is a phenomenon resulting from the surface tension of the
sample fluid and the thermodynamic tendency of a liquid to minimize its surface

area. For example, U.S. Patent No. 5,141,868 discloses a test strip having a cavity sized sufficiently small to draw sample liquid therein by capillary action. The cavity is defined by two parallel plates spaced about 1 mm apart by two epoxy strips extending lengthwise along lateral sides of the plates. The cavity is open at both
5 ends, one of which receives the sample, and the other of which allows air to escape. The cavity includes an electrode structure and carries a coating of a material appropriate to the test to be performed by the test strip.

Numerous variations of the reagent coating are possible depending upon the specific analyte(s) to be tested, and there are typically numerous chemistries
10 available for use with each of the various analytes. Generally speaking, however, it is desirable to form the reagent layer in the test strip or biosensor as thin and as uniform as possible. For example, as sample volumes and thus the size of the sample-receiving chamber continue to get smaller, variations in thickness of the reagent layer increasingly affect the accuracy of the test result. Further, in test strips
15 having smaller cavities, the reagent layer must be thinner in order to leave ample space in the chamber to receive the sample. Additionally, a thinner layer will hydrate more quickly and will therefore produce a quicker test result.

While forming a thin and uniform reagent layer that hydrates quickly in an extremely small volume is desirable, it is not easily obtained because of the
20 difficulties in working with very small volumes of liquid reagent. For example, one prior art approach to forming the reagent layer is to deposit the same into the sample-receiving chamber after the latter is formed in the test strip. However, this can result in a more uneven reagent layer due to phenomena such as the formation of a meniscus at the perimeter of the chamber, which in turn results in the reagent
25 having a different thickness adjacent to the side walls of the chamber than in the interior portion. This can cause inconsistency in the filling of the chamber, prolonged dissolution intervals, and inconsistent mixing of the reagent with the sample fluid, and, ultimately, poor test results.

It is known to provide elongated webs of test strip material on which a
30 continuous stripe of reagent is deposited. The test strips are then cut from the elongated web, the cuts extending through the reagent layer. Typically in such test strips so formed, the sample-receiving chamber has a floor with two different levels,

a lower level provided by a base substrate material, and an elevated level provided by the reagent layer. The discontinuities in the floor of the chamber can be problematic. First, since the top of the reagent layer must be spaced typically a minimum distance from the ceiling or top of the chamber to allow ample space for sample, the lower height of the base substrate undesirably creates wasted chamber space.

Second, the edges of the reagent layer that are formed by the reagent stripe will likely be uneven in thickness and width. For example, the width of the reagent stripe can vary substantially as it is applied to a long web of material, which in turn results in some strips having more reagent than others after the strips are cut from the web. Further, the edge quality of the reagent stripe is highly variable, depending upon many factors, such as the means used to apply the stripe, its viscosity and the like. These inhomogeneities can lead to inaccuracies in determining analyte concentration.

It is an object of the present invention to form a test strip having a small sample-receiving chamber but including a reagent layer therein that avoids the drawbacks discussed above.

SUMMARY OF THE INVENTION

The present invention provides a test strip having a small sample-receiving chamber less than 1 microliter, preferably less than 0.5 microliter. The sample-receiving chamber includes a uniform reagent layer that avoids the undesirable edge and meniscus effects described above. The present invention further provides a cost-effective method for mass-producing these inventive test strips.

In one form thereof, the present invention provides a test strip having meter insertion and sample-receiving ends, first and second sides, and a central longitudinal axis that is oriented substantially parallel to the two sides. The test strip defines a downstream direction from the sample-receiving end to the meter insertion end. The test strip includes a base substrate having an electrode formed thereon. A spacing layer overlies the base substrate and has a void or cavity that at least partially defines the sample-receiving chamber. The reagent layer is disposed in the sample-receiving chamber and covers a portion of the base substrate and the electrode. The reagent layer is sandwiched between the spacing layer and the base substrate and extends to the first and second sides of the base substrate and also extends to the sample-receiving end of the test strip.

In a preferred form, the sample-receiving chamber defines a channel aligned with the longitudinal axis and has a sample-receiving opening disposed at the sample-receiving end. Thus, the reagent layer extends to the sample-receiving opening. The advantage of this arrangement is that an even and smooth reagent layer coats most or all of the floor of the sample-receiving chamber, thereby avoiding edge discontinuities, meniscus effects and other inhomogeneities in the reagent layer. Instead, the present invention provides a reagent layer with a thin, uniform surface extending across the floor of the sample-receiving chamber, providing a highly accurate test strip.

The test strip preferably includes a covering layer overlying the spacing layer. The covering layer includes a vent opening that communicates with the sample-receiving chamber, thereby allowing air to escape the chamber as fluid enters it. More preferably, the reagent layer extends in the downstream direction all

the way to the vent opening, if not slightly beyond it. In this manner, as the sample fluid is drawn into the sample-receiving chamber by capillary action, it experiences a uniform and thin reagent layer until it stops at the vent opening, which is preferably provided as a slot with one side thereof being hydrophobic, thereby
5 effectively halting movement of the sample beyond it.

In another preferred form, the electrodes on the base substrate include a working electrode and a counter electrode, both of which are covered by the reagent layer. The reagent layer extends in the downstream direction beyond the electrodes.

The reagent layer preferably defines first and second reagent layer side edges
10 that are substantially aligned with the first and second sides of the test strip. The reagent layer also forms a reagent layer end edge that is aligned with the sample-receiving end of the test strip. As described below, the reagent layer edges are formed as part of the die cutting process that forms individual test strips from a larger web, and this provides a smooth and even edge that avoids the undesirable
15 edge effects noted above.

In another preferred form, the test strip includes an adhesive layer sandwiched between the spacing layer and the base substrate. As described herein, as part of the mass-production process, the adhesive layer is formed having an edge profile that is aligned with the peripheral edge of the sample-receiving chamber. In
20 preferred embodiments, the adhesive forms a seal around the periphery of the sample-receiving chamber, thereby preventing sample fluid from wicking laterally outside of the chamber and spreading under the spacing layer.

In another form thereof, the present invention provides a method of mass producing the novel test strips described above. In this inventive method, a web of
25 base substrate material is provided that has first and second web edges. A plurality of spaced electrode sets are formed on the web. A stripe of reagent material is applied to the web and covers at least one electrode of the electrode sets. The stripe is oriented substantially parallel to the first web edge. The inventive test strips are then cut from the web. The cuts made to the web define the first and second sides
30 and the sample-receiving end of the test strip. Further, during the cutting process, a portion of the reagent stripe is cut and separated from the sample-receiving end of the test strip. This results in test strips with reagent layers that extend to the sample-

receiving end as well as the first and second sides of the test strips. Since the reagent is hydrophilic, having it extend to the dosing end of the strip advantageously promotes wicking of the blood sample into the capillary chamber and avoids dose hesitation.

5 In a preferred form, before the test strips are cut, a web of spacing material having a series of spaced cavities is provided. The cavities are aligned with the longitudinal axes of the test strips that are to be cut from the web, and then the spacing material is laminated to the web. Preferably, the spacing material includes an adhesive on the bottom side thereof which serves to adhere the web of spacing
10 layer material to the web of base substrate. More preferably, after laminating the web of spacing layer material, a web of covering layer material is aligned and then laminated over the web of spacing layer material. In this manner, each cavity defines a sample-receiving chamber.

The inventive reagent layer formed by this method has several advantages.
15 Since it is very thin, the reagent layer can be made homogenous in thickness. Further, thin reagent layers contain only small amounts of reagent which in turn leads to fast reaction times. The reactions only have short diffusion times, and the thin reagent layers are quickly soluble and therefore lead to quick reagent availability and a rapid equilibration of the matrix after sample rehydration of the
20 reagent stripe, which in turn leads to fast measurements.

The inventive reagent layers can not only be made very thin but also show a high homogeneity down and across the web in the reaction area. The reagent layer in the test area or sample receiving chamber is flat and uniform in thickness. Thickness variations in the coated stripe occur preferably only on the outer 0.2 cm
25 (or less) edges of the stripe. In preferred embodiments, however, these areas advantageously are either covered by the spacing layer or trimmed from the dosing end of the strip in the final assembly process.

Further, since the reagent layer is applied wet and then dried before laminating the spacing layer to the test strip, the reagent layer can thus be formed
30 smooth, thin and with uniform thickness, substantially covering the entire floor of the sample-receiving chamber. This inventive process helps improve the

reproducibility of the quantity, location, thickness and other properties of the reagent layer, which in turn improves the accuracy of the test result.

The present invention provides a very easy-to-dose test strip and provides a robust but flexible manufacturing process. The various other features that
5 characterize the invention are pointed out with particularity in the attached claims. For a better understanding of the invention, its advantages, and objectives obtained therefrom, reference should be made to the drawings and to the accompanying description, in which there is illustrated and described preferred embodiments of the invention.

BRIEF DESCRIPTION OF THE DRAWINGS

Referring now to the drawings, wherein like reference numerals and letters indicate corresponding structure throughout the several views:

5 FIG. 1 is a perspective view of a test strip or biosensor in accordance with the present invention.

 FIG. 2 is an exploded, perspective view of the biosensor of FIG. 1.

 FIG. 3 is a cross-sectional view of a portion of the biosensor of FIG. 1, additionally illustrating adhesive layers that have been omitted from FIGS. 1-2.

10 FIG. 4 is a top, plan view of a portion of the biosensor of FIG. 1, with portions broken away to show underlying details.

 FIGS. 5 and 5A show a process flow diagram for a method for producing a biosensor in accordance with the present invention.

 FIG. 6 is a perspective view showing the reel-to-reel processing and cutting
15 of a web material useful in forming the bottom substrate of the biosensor of the present invention.

 FIG. 7 is a perspective view of a portion of a webbing, showing an exemplary pattern of electrical components on the base substrate.

 FIG. 8 is a perspective view of a portion of the webbing of FIG. 7 and
20 including a reagent composition coated thereon.

 Fig. 8A is a diagrammatic view illustrating the slot-die coating process that produces the reagent illustrated in FIG. 8.

 FIG. 9 is an exploded, perspective view showing a spacing layer and the associated adhesive layers and release liners.

25 FIG. 10 is an exploded perspective view of a portion of the spacing layer with pre-capillary chambers cut out and the spacing layer being aligned for lamination to a base substrate having electrode patterns thereon.

 FIG. 11 is a perspective view of an assembly of the base substrate with the spacing layer.

30 FIG. 12 is an exploded, perspective view showing the combination of the body and chamber covers for assembly onto the base substrate and spacing layer.

FIG. 13 is a perspective view of a portion of an assembly including the several layers comprising the biosensor.

FIG. 14 is a perspective view of a portion of webbing including several detachable biosensors.

5 FIG. 15 is a perspective view of a single biosensor separated from the assembled webbing.

DESCRIPTION OF THE PREFERRED EMBODIMENTS

For the purposes of promoting an understanding of the principles of the invention, reference will now be made to the specific embodiments illustrated herein and specific language will be used to describe the same. It will nevertheless be understood that no limitation of the scope of the invention is thereby intended. Any alterations and further modifications in the described processes or devices, and any further applications of the principles of the invention as described herein, are contemplated as would normally occur to one skilled in the art to which the invention relates.

System

The present invention relates to a system that is useful for assessing an analyte in a sample fluid. The system includes devices and methods for evaluating the sample fluid for the target analyte. As more fully described hereafter, the evaluation may range from detecting the presence of the analyte to determining the concentration of the analyte. The analyte and the sample fluid may be any for which the test system is appropriate. For purposes of explanation only, a preferred embodiment is described in which the analyte is glucose and the sample fluid is blood or interstitial fluid. However, the present invention clearly is not so limited in scope.

Sensor

One component of the system is an electrochemical sensor including a sample-receiving chamber for the sample fluid, and a suitable reagent for producing an electrochemical signal in the presence of the test analyte. The sensor preferably comprises a disposable test strip, particularly one having a laminar construction providing an edge opening which communicates with the sample-receiving chamber. The reagent is disposed within the sample-receiving chamber in position to provide the electrochemical signal to a working electrode also positioned within the chamber. In appropriate circumstances, such as for glucose detection, the reagent may contain an enzyme and optionally a mediator.

Meter

The sensor is used in combination with a meter for determination of the analyte in the sample fluid. The meter conventionally includes a connection with the electrodes of the sensor and circuitry to evaluate the electrochemical signal corresponding to the concentration of the analyte. The meter may also include
5 means for determining that the sample fluid has been received by the sensor, and that the amount of sample fluid is sufficient for testing. The meter typically will store and display the results of the analysis, or may alternatively provide the data to a separate device.

Analyte – Characteristic

10 The system can provide either a qualitative or quantitative indication for the analyte. In one embodiment, the system indicates simply the presence of the analyte in the sample fluid. The system may also provide a reading of the quantity or concentration of the analyte in the sample fluid. In a preferred embodiment, it is a feature of the present invention that a highly accurate and precise reading of the
15 analyte concentration is quickly obtained from a small volume of sample fluid.

Analyte – Type

The system is useful for the determination of a wide variety of analytes. The test strip, for example, is readily adapted for use with any suitable chemistry that can be used to assess the presence of the analyte. Most preferably, the system is
20 configured and used for the testing of an analyte in a biological fluid. Such analytes may include, for example, glucose, cholesterol, HDL cholesterol, triglycerides, lactates, lactate dehydrogenase, alcohol, uric acid, and 3-hydroxybutyric acid (ketone bodies). Commensurate modifications to the system will be apparent to those skilled in the art. For purposes of explanation, and in a particularly preferred
25 embodiment, the system is described with respect to the detection of glucose in a biological fluid.

Interferants

Test methodologies may be variously affected by the presence of interferants in the sample fluid. For example, the testing for glucose in a blood sample may be
30 impacted by such factors as oxygen, bilirubin, hematocrit, uric acid, ascorbate, acetaminophen, galactose, maltose, and lipids. The present system is adaptable to minimize or eliminate the adverse effects of interferants that may also be present in

the sample fluid. These effects may be addressed by appropriate selection of test materials and parameters, such as by the selection of chemistries that are known to be impacted less, or not at all, by possible interferants. As is known in the art, other steps may also be taken to address possible interferant effects, such as the use of
5 coatings or films that prevent the interferant from entering the test zone. In addition, modifications to the electrode configurations or interrogation methods can be used to minimize the effect of interferants.

Fluid Type

The system is useful with a wide variety of sample fluids, and is preferably
10 used for the detection of analytes in a biological fluid. In this context, the term “biological fluid” includes any bodily fluid in which the analyte can be measured, for example, interstitial fluid, dermal fluid, sweat, tears, urine, amniotic fluid, spinal fluid and blood. The term “blood” in the context of the invention includes whole blood and its cell-free components, namely plasma and serum. In addition, the
15 system is useful in connection with control fluids that are used in conventional fashion to verify the integrity of the system for testing.

In a preferred embodiment, the system is employed for the testing of glucose. The sample fluid in this instance may specifically include, for example, fresh capillary blood obtained from the finger tip or approved alternate sites (e.g.,
20 forearm, palm, ear lobe, upper arm, calf and thigh), fresh venous blood, and control solutions supplied with or for the system.

The fluid may be acquired and delivered to the test strip in any fashion. For example, a blood sample may be obtained in conventional fashion by incising the skin, such as with a lancet, and then contacting the test strip with fluid that appears
25 at the skin surface. It is an aspect of the present invention that the test strip is useful with very small fluid samples. It is therefore a desirable feature of the invention that only a slight incising of the skin is necessary to produce the volume of fluid required for the test, and the pain and other concerns with such method can be minimized or eliminated.

30 It is also well known that different locations on the skin will produce more or less amounts of blood upon lancing. The finger tip, for example, is a commonly used site for obtaining a blood sample because it produces a relatively large amount

of blood upon lancing. However, it is also known that areas that produce larger volumes of blood are generally associated with greater degrees of pain for the user. It is therefore an additional advantage of the present system that the required volume of sample fluid is sufficiently small that the test strip is useful with the amount of blood typically obtained upon lancing less productive, but also less painful, areas of the skin, such as the palm and upper arm. The use of these locations to obtain sample fluids for testing is sometimes referred to as "alternate site testing". The present invention is particularly well suited to use with sample fluids, e.g., blood or interstitial fluid, obtained at these alternate sites.

10 Test Strip – General

Introduction.

The test strip includes several basic components. The strip comprises a small body defining a chamber in which the sample fluid is received for testing. This "sample-receiving chamber" is filled with the sample fluid by suitable means, preferably by capillary action, but also optionally assisted by pressure or vacuum. The sample-receiving chamber includes electrodes and chemistry suitable for producing an electrochemical signal indicative of the analyte in the sample fluid.

Basic Description.

Referring in particular to the drawings, there is shown a preferred embodiment of a test strip useful in accordance with the present invention. The test strip 10 includes a base substrate 12, a spacing layer 14 and a covering layer 16 comprising body cover 18 and chamber cover 20. The spacing layer 14 includes a void portion 22 to provide a sample-receiving chamber 24 extending between the base substrate 12 and the covering layer 16.

The base substrate 12 carries an electrode system 26 including a plurality of electrodes 28 and electrode traces 30 terminating in contact pads 32. The electrodes are defined as those portions of electrode traces 30 that are positioned within the sample-receiving chamber 24. Various configurations of the electrode system 26 may be used, as set forth hereafter. A suitable reagent system 33 overlies at least a portion of the electrodes or electrode pairs 28 within the sample-receiving chamber.

The body cover 18 and the chamber cover 20 overlying the spacing layer 14 define a slot 34 therebetween, the slot defining a vent opening communicating with

the sample-receiving chamber to allow air to escape the chamber as a sample fluid enters the chamber from the edge opening or fluid receiving opening 35. The test strip therefore includes a dosing end 36 and a meter insertion end 38. The shape of the dosing end is typically distinguishable from the meter end so as to aid users. In addition, strip graphics are preferably used to further improve the intuitiveness of the strip design; e.g., arrow 31 indicates the direction of insertion of the strip into the meter.

General Dimensions.

The test strip is a relatively small device that is dimensioned for compactness and ease of storage and use. In a typical embodiment, the strip length is on the order of 20 to 50 mm, preferably about 33 to about 38 mm, in length, and 5 to 15 mm, preferably about 7 to about 9 mm, in width. The distance from the slot or vent opening 34 to the edge of the meter is sized to provide a "grab area" where there is no blood present, and to guard against blood contamination of the meter contact area, and therefore may be in the range of 5 to 35 preferably ≥ 13 mm. The length of the test strip portion (from the meter insertion end 38) that is inserted into the meter is preferably ≤ 6.0 mm along the long axis of the test strip.

The preferred laminar construction of the test strip also provides a device that is relatively thin. The minimal thickness of the strip allows ready packaging of the strip in appropriate containers that are convenient for the user. For example, the overall thickness of the test strip may be about 500 to 525 μm . The thickness of the test strip portion that is inserted into the meter contact may be about 250 μm .

Substrate

The test strip includes a base substrate 12 which comprises an insulating material supporting the electrode system and other components. Typically, plastics such as vinyl polymers, polyimides, polyesters, and styrenes provide the electrical and structural properties which are required. Further, because the test strip is preferably mass producible from rolls of material, it is desirable that the material properties be appropriate to have sufficient flexibility for roll processing, while also giving a useful stiffness to the finished strip. The base substrate can be selected as a flexible polymeric material such as polyester, especially high temperature polyester

materials; polyethylene naphthalate (PEN); and polyimide, or mixtures of two or more of these. Polyimides are available commercially, for example under the trade name Kapton®, from E.I. duPont de Nemours and Company of Wilmington, DE (duPont). A particularly preferred base substrate material is MELINEX® 329
5 available from duPont.

Electrodes

Type.

The invention relates to an “electrochemical sensor”, which is a device configured to detect the presence of, and/or measure the concentration of, an analyte
10 by way of electrochemical oxidation and reduction reactions within the sensor. These reactions are transduced to an electrical signal that can be correlated to an amount or concentration of the analyte. The test strip therefore includes an electrode system 26 comprising a set of measuring electrodes, e.g., at least a working electrode and a counter electrode, within the sample-receiving chamber. The
15 sample-receiving chamber is configured such that sample fluid entering the chamber is placed in electrolytic contact with both the working electrode and the counter electrode. This allows electrical current to flow between the measuring electrodes to effect the electrooxidation or electroreduction of the analyte.

In the context of the present invention, a “working electrode” is an electrode
20 at which analyte is electrooxidized or electroreduced with or without the agency of a redox mediator. The term “counter electrode” refers herein to an electrode that is paired with the working electrode and through which passes an electrochemical current equal in magnitude and opposite in sign to the current passed through the working electrode. The term “counter electrode” is meant to include counter
25 electrodes which also function as reference electrodes (i.e., counter/reference electrodes).

Electrode material.

The working and counter electrodes, and the remaining portions of the electrode system, may be formed from a variety of materials, as known in the art.
30 The electrodes should have a relatively low electrical resistance and should be electrochemically inert over the operating range of the test strip. Suitable conductors for the working electrode include gold, palladium, platinum, carbon,

titanium, ruthenium dioxide, and indium tin oxide, and iridium, as well as others. The counter electrode may be made of the same or different materials, e.g., silver/silver chloride. In a preferred embodiment, the working and counter electrodes are both gold electrodes.

5

Electrode application.

The electrodes may be applied to the base substrate in any fashion that yields electrodes of adequate conductivity and integrity. Exemplary processes are well known in the art, and include, for example, sputtering, printing, etc. In a preferred embodiment, gold electrodes are provided by coating the base substrate and then removing selected portions of the coating to yield the electrode system. A preferred removal method is laser ablation, and more preferably broad field laser ablation, as disclosed in United States Patent Application, Serial No. 10/601,144, filed on June 20, 2003, entitled Method of Making a Biosensor, the disclosure of which is hereby incorporated by reference.

10
15

Laser ablative techniques typically include ablating a single metallic layer or a multi-layer composition that includes an insulating material and a conductive material, e.g., a metallic-laminate of a metal layer coated on or laminated to an insulating material (discussed below). The metallic layer may contain pure metals, alloys, or other materials, which are metallic conductors. Examples of metals or metallic-like conductors include: aluminum, carbon (such as graphite), cobalt, copper, gallium, gold, indium, iridium, iron, lead, magnesium, mercury (as an amalgam), nickel, niobium, osmium, palladium, platinum, rhenium, rhodium, selenium, silicon (such as highly doped polycrystalline silicon), silver, tantalum, tin, titanium, tungsten, uranium, vanadium, zinc, zirconium, mixtures thereof, and alloys or solid solutions of these materials. Preferably, the materials are selected to be essentially unreactive to biological systems; such materials include: gold, platinum, palladium, iridium, silver, or alloys of these metals or indium tin oxide. The metallic layer may be any desired thickness. In a preferred embodiment, the thickness is about 500 nm.

20
25
30

Configuration.

The electrode system may have a variety of configurations suited to the operation of the test strip and meter. For any embodiment, the working and counter electrodes preferably are positioned and dimensioned to minimize the volume of sample fluid required to cover them. It is also preferable that the electrodes be
5 configured to maintain a current flux of sufficient magnitude as to be measurable using a relatively inexpensive hand-held meter.

By way of further example, a preferred embodiment includes a counter electrode which extends around both sides of the working electrode. The counter electrode therefore has two elements, one in front of the working electrode and the
10 other behind the working electrode, as the sample fluid enters the sample-receiving chamber. More specifically, the counter electrode includes elements 40 and 42 which extend across the sample-receiving chamber. Each of these elements is about 250 μm wide. The working electrode element 44 has a width of about 250 μm , and is spaced from each of the two counter electrode elements by about 255 μm . It will
15 be appreciated that this is only one of a number of configurations for the measuring electrodes.

The traces 30 and the contact pads 32 may be provided in a variety of fashions consistent with their intended function relative to the test strip. These components of the electrode system are preferably composed of the same material as
20 the electrodes, and are preferably applied to the base substrate in the same manner and simultaneously with the application of the electrodes. In a preferred embodiment, the traces and contact pads are gold, and are formed by laser ablation, particularly as described in United States Patent Application, Serial No. 10/601,144, which was incorporated by reference hereinabove. However, alternate materials and
25 methods of application may be employed.

Chemistry

Reagent Composition.

The test strip includes a chemical reagent within the sample-receiving chamber for reacting with the test analyte to produce the electrochemical signal that
30 represents the presence of the analyte in the sample fluid. The reagent layer can include a variety of active components selected to determine the presence and/or

concentration of various analytes. The test chemistry is therefore selected in respect to the analyte to be assessed. As is well known in the art, there are numerous chemistries available for use with each of various analytes. For example, in one preferred embodiment, the test strip of the present invention can include one or more enzymes, co-enzymes, and co-factors, which can be selected to determine the presence of glucose in blood. The selection of an appropriate chemistry is therefore well within the skill in the art, and further description herein is not required in order to enable one to make and use the test strips with various analytes.

Adjuvants.

10 In conventional fashion, the reagent chemistry may include a variety of adjuvants to enhance the reagent properties or characteristics. For example, the chemistry may include materials to facilitate the placement of the reagent composition onto the test strip and to improve its adherence to the strip, or for increasing the rate of hydration of the reagent composition by the sample fluid. 15 Additionally, the reagent layer can include components selected to enhance the physical properties of the resulting dried reagent layer, and the uptake of a liquid test sample for analysis. Examples of adjuvant materials to be used with the reagent composition include thickeners, viscosity modulators, film formers, stabilizers, buffers, detergents, gelling agents, fillers, film openers, coloring agents, and agents 20 endowing thixotropy.

In a preferred embodiment of the test sample, the majority of the chamber is hollow before use. In the very small sample chamber of the test strips according to the present invention, it is preferable that the reagent layer be thin and uniform. Since the sample-receiving chamber is very small, less than about 1 μ l, the depth or 25 vertical height of the chamber is small. Consequently, the reagent layer should not occupy the majority of the internal cavity of the chamber. The reagent layer should be sufficiently thin to leave ample space for the test sample in the chamber. Further, the liquid test sample will hydrate or dissolve the thin reagent layer more quickly. As discussed in the above reaction scheme, the mediator and mediator redox 30 products diffuse through and within the reagent layer/gradient to the electrodes. The reactive components and intermediates will have a short distance to diffuse through

a thin reagent, therefore, diffusion to the electrodes will occur in less time.

Additionally, the capture efficiency of mediator redox products at an electrode will be greater for a thin layer of enzyme than a thick layer.

Conversely, a thick reagent layer will take more time for the liquid test
5 sample to hydrate or dissolve, and a thick reagent layer will increase the time that it takes for the mediator/mediator redox products to approach the electrodes. This can delay the time to determine the analyte concentration and introduce errors into the determination.

It is preferred that the reagent layer have a uniform thickness. Thickness
10 inhomogeneity can lead to variability in determining the analyte concentration. In a preferred embodiment, the reagent layer has a uniform thickness throughout the entire sample receiving chamber. In this preferred embodiment, the reagent layer is not thicker around the perimeter of the sample receiving chamber adjacent the vertical side walls that define the chamber than in the central portion of the chamber.
15 Consequently, the reagent layer does not exhibit a meniscus profile.

The reagent composition is formulated as a viscous solution that can be deposited in a thin, uniform layer on the base layer. The reagent composition includes thickeners and thixotropic agents to enhance the physical properties of the reagent layer. The thickeners are selected to provide a thick, liquid matrix having
20 the remaining components homogeneously dispersed therein. The thickening and thixotropic agents also inhibit the liquid or semi-paste material from running or spreading over the surface of the base layer after it has been deposited and before it dries. After the reagent composition is deposited, it quickly dries to a readily hydratable matrix.

25 The reagent composition is provided to dry rapidly either with air drying or heat drying. After drying, the deposited reagent layer exhibits a thickness of between about 1 micron and about 20 microns. More preferably, the dried reagent layer exhibits a thickness of between about 2 microns and about 6 microns.

The reagent composition can be deposited on the test strip surface using a
30 variety of coating methods including curtain coating, hot melt coating, rotary screen coating, doctor blade or air knife coating, Meyer bar coating, and reverse roll coating techniques. These techniques are known to those skilled in the art.

Preferably, the reagent composition is applied to the web by a slot-die coating process that is described in more detail below. Preferably, the reagent layer is deposited on the flexible web as a wet composition at a thickness of between about 40 μm and about 100 μm . More preferably, the reagent composition is deposited as
5 a wet composition at a thickness of between about 60 μm and about 80 μm . The composition may be applied as a uniformly thin layer of a reagent directly on top of the measuring electrodes and along the length of a web of multiple test strips, as a continuous narrow band. In preferred embodiments, the narrow band has a width of between about 7 mm and 8 mm and a dry thickness of between about 3 μm and
10 about 20 μm . The composition may also be applied onto other electrodes that may reside in the sample-receiving chamber, depending on the desired functionality of such extraneous electrodes.

Spacing Layer

Configuration.

15 The test strip includes a spacing layer 14 which overlies the base substrate and which in part defines the sample-receiving chamber. In particular, the spacing layer 14 includes a void portion 22 substantially defining the height and the perimeter of the sample-receiving chamber 24. The void portion 22 is conveniently placed to have an edge opening whereby the sample fluid is contacted with the edge
20 opening to enter into the sample-receiving chamber. The edge opening preferably is located at the end of the test strip, although it will be appreciated that placement on a side edge is also useful.

Materials.

25 The spacing layer 14 may be made of any material useful for fabrication with the test strip. Because the spacing layer partially defines the height of the sample-receiving chamber, the material should have sufficient strength at thicknesses appropriate to the desired height of the chamber. Another function of the spacing layer is to protect the electrode traces that extend along the upper surface of base
30 substrate 12. The material should also be readily attached to the base substrate and the cover materials, either by heat-sensitive or pressure-sensitive adhesives, or other

means such as heat or laser welding. Examples of suitable materials include a 100 μm PET, PEN foil coated or combined with adhesives such as ARCare 90132 from Adhesives Research Inc.

Covering Layer

5 Configuration.

A covering layer 16 is received over and attached to the spacing layer 14. One function of the covering layer is to form the top surface of the sample-receiving chamber. Another function is the provision of a hydrophilic surface to aid in acquisition of the test sample. In addition, the covering layer 16 preferably defines a
10 vent opening 34 that allows air to escape from the interior of the chamber as the sample fluid enters and moves into the sample-receiving chamber.

Preferably, body cover 18 and chamber cover 20 comprise two separate members for ease in fabrication and in forming the vent opening. Body cover 18 and chamber cover 20 are both disposed in substantially the same horizontal plane.
15 The chamber cover 20 substantially covers the void portion 22 of the spacing layer, and forms the top of the sample-receiving chamber. The chamber cover preferably includes a hydrophilic coating or treatment 21 on its underside, as described in more detail below. The body cover and the chamber cover are positioned end to end in the lengthwise direction along the test strip and include slot 34 therebetween as
20 shown in FIG. 1. The slot is located adjacent the interior end of the void portion 22 of the spacing layer and forms a small gap that spaces chamber cover 20 from body cover 18.

The slot is located at a position relative to the sample-receiving chamber that is interior of the location of the electrode system 26. Sample fluid entering the
25 sample-receiving chamber will progress as far as the vent opening, but no further. When viewed from the top, the slot provides a visual indication of a "fill-line," as described herein. The placement of the vent opening therefore assures that sufficient sample fluid can be received to fully cover the electrode system. At the same time, the placement of the vent opening will inhibit continued wicking of the sample fluid
30 beyond the region of the electrode system.

At the same time, the vent construction may be made in a manner to inhibit the wicking of sample fluid laterally along the slot beyond the middle area that

overlies the sample receiving chamber 24. For example, the body cover is preferably secured to the spacing layer by means of an adhesive 46, as shown in FIG. 3. The use of a hydrophobic adhesive will inhibit blood, interstitial fluid, and other aqueous liquids from moving along the laterally-extending slot by capillary action. The entire body cover, or portions adjacent to the vent opening, may also be hydrophobic to inhibit wicking. Materials and methods for providing hydrophobic properties for a surface of a material are well known in the art. The chamber cover may be secured to the spacing layer by the same or different adhesive than adhesive 46, as explained below.

Adhesive 49 secures the spacing layer to the base substrate 12. Adhesive 46, as well as adhesive 49 and the material for spacing layer 14, are all formed of hydrophobic material in the illustrated embodiment. As such the vertical walls of the capillary chamber formed in strip 10 are hydrophobic. By contrast, the floor of the chamber is covered with a hydrophilic reagent and the underside of layer 20 is coated with a hydrophilic coating 21 (FIG. 2). In other words, the horizontal surfaces in the capillary are hydrophilic while the vertical surfaces are hydrophobic. This has been found to promote good wicking of the sample into the capillary chamber, yet prevents unwanted migration of the sample laterally from the chamber, e.g., between the spacer layer and the base substrate.

Materials.

The body cover and chamber cover may be made of any materials useful for fabrication with the test strip. The materials for the body cover and the chamber cover may be the same or different. The materials should be readily attached to the spacing layer, either by heat-sensitive or pressure-sensitive adhesives, or other means such as heat or laser welding. Examples of suitable materials for both the chamber cover and body cover include approximately 127 μm thick foil of PET. The chamber cover preferably includes a hydrophilic layer 21 as disclosed in WO 02/085185, ARFlow® 90191 from Adhesives Research Inc.

The covering layer 16 may also be used to facilitate viewing of the sample fluid as it enters the sample-receiving chamber. This is accomplished by providing a

contrast in color or shading between the chamber and the surrounding area. For example, in one approach the portion of the spacing layer 14 that surrounds void 22 is provided with a color that contrasts with the color of the bottom of the sample-receiving chamber, e.g., the color of the chemical reagent layer positioned at the bottom of the chamber. This contrasting color may be provided, for example, by the application of an ink or other coloring agent to the portions of the spacing layer adjacent the sample-receiving chamber. A colored section 23 of layer 14 is pictured in FIG. 2. The chamber cover 20 is then provided as a transparent or translucent material that allows the user to view the chamber and the adjacent spacing layer. As sample fluid enters from the edge of the test strip, the user is able to observe its progress as it moves by capillary action toward the vent opening. This type of feature is further described in US Patent No. 5,997,817, issued to Crismore et al. on December 7, 1999, and is hereby incorporated by reference.

Capillary

The sample-receiving chamber formed by the base substrate, spacing layer and chamber cover essentially comprises several sections into which the sample fluid will travel. A first, entry section 48 extends from the edge opening to the area of the measuring electrode system. A second, test section 50 extends through the area of the electrode system. A third section 52 extends from the measuring electrode system to the vent opening. It will be appreciated that the testing of the sample fluid occurs in the area of the electrode system in the test section. However, the sample fluid will also fill the other sections of the chamber in the course of filling the test strip.

Dimensions.

The height and width of the sample-receiving chamber are selected based upon a variety of considerations, including the fluid being tested and the analyte at issue. For example, the chamber dimensions are preferably sized to promote capillary flow of the test fluid into the chamber. Preferred chamber heights for use with blood, for example, are from about 50 μm to about 200 μm , and most preferably from 120 to 180 μm . In a preferred embodiment, the chamber height is about 150 μm . The width of the chamber may similarly be selected to match a desired sample fluid and analyte. For example, the chamber should be sufficiently

wide to expose a desired amount of the working and counter electrodes, and should be narrow enough to avoid the requirement of an undue amount of sample fluid for testing. The width of the sample-receiving chamber and the width of the working electrode define the area of the working electrode. The area represents a further design consideration as it relates to signal amplitude and instrumentation design.

5 Volume.

The sample-receiving chamber is preferably provided as having a minimal volume, in order to reduce the amount of sample fluid needed for conducting a test. The overall sample-receiving chamber, including all of the three sections extending from the edge opening to the vent opening, has a total volume that can be considered to be a factor of the area of the chamber from the edge to the vent, and the height of the chamber from the base substrate to the chamber cover 20. However, the "net chamber volume" comprises the volume of sample fluid required to fill this space. The net chamber volume of the sample-receiving chamber will be the equivalent of the total chamber volume less the volume occupied by the electrodes, the reagent,

15 and perhaps other items such as a sorbent material, if included.

As previously indicated, the volume of the overall sample-receiving chamber is comprised of the volumes attributable to the three sections of the chamber. Each of the sections is generally sized to be as small as practical for the operation of the test strip. However, there are considerations, and possibly other functions, that will impact on the size of each section.

20

The chamber volumes are a factor of both height and area. The height is a result of the thickness of the spacing layer and the thickness of the adhesives used to secure the spacing layer to the other layers. For example, the base substrate and the chamber cover are attached to opposite sides of the spacing layer. One method of attachment is the heat or laser sealing of the materials. It is preferred, however, to attach these layers by the use of suitable adhesives, such as heat-sensitive or pressure-sensitive adhesives. In this approach, the height of the sample-receiving chamber, i.e., the distance between the facing surfaces of the bottom substrate and the chamber cover, will be impacted by the thickness of the adhesive layers. As shown in FIG. 3, chamber 24 is bounded on its bottom side by reagent layer 33 and

25
30

its top side by chamber cover 20. However, adhesive layers 46 and 49 as well as spacing layer 14 define the total height of chamber 24.

Further, in a preferred embodiment, the reagent layer 33 extends between base substrate 12 and spacing layer 14 and indeed extends the entire width of the test strip, as described below. The height of the chamber may therefore also be increased due to the presence of the reagent layer underlying the spacing layer. In this embodiment, and if adhesive is employed, it has been found that the adhesive may combine with the test reagent, at least to an extent that causes the adhesive to fill somewhat into and around the reagent. The heights of the reagent and adhesive layers therefore are not necessarily additive in the final test strip. Rather, the height of the resulting space between the base substrate and the spacing layer is somewhat less than the combination of the heights of the separate reagent and adhesive layers prior to lamination.

It has also been found that the combination of the adhesive and the reagent advantageously helps to create a seal along the edge of the sample-receiving chamber. This inhibits sample fluid from wicking into the reagent material present in the space between the base substrate and the spacing layer in the time frame necessary for performing a test.

The first entry section is available to receive the sample fluid and direct it to the measuring electrodes. This section can be quite small in size, and may comprise only a short segment of the chamber. The length of this section is preferably less than 1200 μm .

The second testing section includes the test or measuring electrodes, and is also sized to require a minimal volume of sample fluid. A primary factor controlling the size of this second section will be the type, number, size, signal strength, and configuration of the measuring electrodes. The length of this section is preferably about 1260 μm . A preferred volume is about 0.265 μL , based on a capillary height of 0.15mm, and a capillary width of 1.4 mm.

The sample fluid moves past the measuring electrodes and into the third section. This provides assurance, and preferably allows for specific confirmation, that the measuring electrodes are properly wetted. This confirmation may be by visual observation by the user, or by automatic detecting means. For example, dose

sufficiency electrodes may be placed in this section to detect when the sample fluid has progressed into this section to a point that the wetting of the measuring electrodes is assured. This can be used as a trigger for initiating the application of the potential to the electrodes. The length of this section is preferably 50 to 500 μm , and more preferably 255 to 400 μm . The volume is preferably 0.01 to 0.1 μL , and more preferably 0.05 to 0.08 μL .

In a preferred embodiment, the overall net chamber volume of the sample-receiving chamber is less than about 1 μL , and is more preferably less than about 0.5 μL . Desirable ranges for the net chamber volume of the sample-receiving chamber include volumes from about 0.15 to about 1.4 μL , more preferably from about 0.4 to about 0.7 μL .

Sorbent.

The sample chamber may be otherwise empty, which is preferred, or may alternatively include a sorbent material. Suitable sorbent materials include polyester, nylon, cellulose, and cellulose derivatives such as nitrocellulose. A sorbent material could be included to facilitate the uptake of the sample fluid by assisting in wicking the fluid into the chamber. The use of a sorbent material would also serve to further reduce the void volume of the sample-receiving chamber for reception of the sample fluid.

Fill Method.

The preferred method of filling the sample chamber is by capillary action. In addition, the filling of the test strip can be augmented by other means, such as applying a pressure on the sample fluid to push it into the sample chamber, and/or creating a vacuum on the sample chamber to pull the sample fluid into the chamber.

Hydrophilic coating.

For purposes of capillary filling of the sample-receiving chamber, various approaches are available to facilitate the movement of the sample fluid into the chamber. For example, any or all of the surfaces defining the chamber may be selected or treated to improve hydrophilicity. Such treatment may comprise the use of known hydrophilic materials, application of a hydrophilic material onto the surface, or treatment of the surfaces to increase hydrophilicity, as described below.

In addition, the reagent composition may be formulated to be readily hydrated and to encourage filling of the sample-receiving chamber. As previously indicated, a sorbent may also be used.

Testing for Analyte

5 The electrochemical sensor is operated by applying a suitable potential or series of potentials across the working and counter electrodes, and across the dose sufficiency electrodes. When a mediator is used, the magnitude of the required potential across the working and counter electrodes will be dependent on the redox mediator. Moreover, the potential at the electrode where the analyte is electrolyzed
10 is typically large enough to drive the electrochemical reaction to or near completion, but the magnitude of the potential is preferably not large enough to induce significant electrochemical reaction of interferants. For glucose, for example, an applied potential difference typically is between about +100 mV and about +550 mV when using a DC potential. When using AC potentials these can be typically be 5 to
15 100 mV RMS.

A potential may be applied before or after the sample begins to enter the sample-receiving chamber. However, a potential is preferably applied after the sample has entered the chamber, and more preferably after it has been determined that there is a sufficient amount of sample in the sample-receiving chamber for
20 conducting a test. The timing of the application of a potential may be triggered in a variety of fashions, including visual observation by the user, a time delay following sampling of the fluid to the test strip, or upon electrical or other automated detection of a sufficient amount of sample fluid in the chamber. The visual and electrical alternatives also may act as redundant failsafes to assure proper operation of the
25 device. Preferably, the test strip and system utilize separate detecting means, such as dose sufficiency electrodes, for determining when the fluid sample has sufficiently filled the chamber.

When a potential is applied and the sample fluid is in the sample-receiving chamber, an electrical current will flow between the working electrode and the
30 counter electrode. The current can be a result of the electrolysis of the analyte in the sample fluid when a potential of sufficient magnitude is applied. In this case electrochemical reaction occurs via the redox mediator, generally as previously

described. In the case where small amplitude potential is applied, particularly in the case of AC potentials, the current is produced not necessarily by electrolysis, but by ionic motion and response of the dielectric in the sample chamber. Those skilled in the art will recognize that there are many different reaction mechanisms that will
5 achieve the same result.

Control solution

A test may be applied to the test strip after dosing to confirm that a control solution, and even that the correct control solution, has been administered. The control solutions aid the user in confirming that the entire system is functioning
10 within design specifications, and that the test strips have not been stored improperly or otherwise mistreated. Acceptable strips will recover values within specified tolerance ranges for the particular strip lot being tested. The tolerance ranges in question will be published for each strip lot on the container label.

Method of Making Strip

15 In a preferred embodiment, the sensor comprises a multi-layered, laminate test strip 10. As previously described, the laminate includes a base substrate 12, a spacing layer 14, and a covering layer 16. These components may be assembled in various ways. For example, the components may be assembled by use of adhesives, heat sealing, laser welding, and a variety of other suitable techniques appropriate for
20 securing the adjacent materials. The test strips are preferably assembled in a large number on a single sheet or web, and the strips are thereafter separated for storage and use.

The laminate test strip may be assembled sequentially by successively laying down one layer at a time. Alternatively, the test strip can be prepared by assembling
25 and processing individual components or layers, which are then laminated together to provide the functional test strip. In one preferred form, two or more basic components of the test strip are prepared simultaneously. Then in one or a series of assembly or laminating steps, the basic components are combined to produce the test strip, which may or may not require further processing. In a preferred embodiment,
30 the test strip is assembled from three basic components: a metallized substrate preferably with a reagent layer coated on metallic electrodes defined on the

substrate, a spacing layer having a cavity preformed therein, and one or more top or cover layers.

With such small dimensions for the sample-receiving chamber, the characteristics of the reagent layer can have a significant impact on the operation of the test strip, particularly in view of hydration and mixing characteristics. The reproducibility of the quantity, location, thickness and other properties of the reagent layer is therefore important. It is therefore desirable for the composition to include materials which specifically enhance the physical characteristics, such as the uniformity and flatness, of the applied layer.

In one particular aspect, the test strip includes a unique manner of incorporating the reagent. The reagent is placed in the sample-receiving chamber at least on the working electrode, and preferably also on the counter electrode. The reagent may be applied to the test strip in a variety of fashions as is well understood in the art. In a preferred embodiment, the reagent composition is applied as a thin coating over the electrodes supported on the base substrate.

More particularly, the reagent is placed onto the base substrate in a manner that positions the reagent composition between the base substrate and the spacing layer. This manner of application helps to make the reagent layer more flat and uniform in thickness. In contrast, a procedure of the prior art has been to first prepare the reaction well or cavity, and to then fill the reagent into the well. However, this can result in a more uneven reagent layer due to phenomena such as the formation of a meniscus at the perimeter of the well. This in turn can cause the reagent to have a different thickness adjacent to the side walls of the reaction well than in the interior portion, which can cause inconsistency in the filling of the chamber, prolonged dissolution intervals, and inconsistent mixing of the reagent with the sample fluid, and the ultimate test results. By placing the reagent onto the base substrate before the spacing layer is added, there is no meniscus effect to disrupt the even layering of the reagent as it dries on the base substrate. In addition, this method of application facilitates the mass production of the test strips.

Referring to the drawings, the test strip 10 is shown as including a reagent layer 33 that extends between the bottom substrate 12 and the spacing layer 14. More particularly, the reagent forms a layer 33 which covers both the top surface of

the bottom substrate 12 and the electrodes 28. The reagent covers at least the working electrode, and preferably also the counter electrode. In the most preferred embodiment, the reagent layer extends the full width of the test strip. The reagent layer also preferably extends from the end edge to the vent opening. The reagent layer thus extends under the spacing layer and is sandwiched between the spacing layer and the base substrate. In the illustrated embodiment, the reagent layer extends to both side edges and the dosing edge of the test strip 10.

As described in further detail below, during the manufacturing process, test strips 10 are cut from a web of material having an elongated, continuous "reagent stripe." The cutting process cuts through the reagent layer on two sides and on its end, such that each test strip so formed has a reagent layer that defines reagent layer side edges and an end edge. The reagent layer side edges are aligned with the side edges of the test strip while the reagent layer end edge is aligned with the end edge of the test strip. In other words, the reagent layer edges are coextensive with the edges of the test strip. Having the reagent layer extend to the dosing edge (which can be a side or end edge of the strip) helps promote wicking of the sample fluid into the sample receiving chamber, since the reagent is hydrophilic. Having the reagent layer extend to the sides of the strip advantageously provides a smooth substrate to which the spacing layer is laminated.

The reagent composition is applied to the bottom or base substrate in any suitable fashion that provides a desired and uniform layer which will ultimately extend under the spacing layer. The reagent is preferably applied in a continuous coating directly onto the bottom substrate, and onto the electrodes received thereon. As described hereafter, the reagent composition is most preferably applied in the course of producing a large quantity of test strips on a webbing of material. In this manner, the reagent may be applied in the way of a continuous stripe of material that extends over a substrate roll that is later separated into individual test strips. The reagent composition is allowed to dry or otherwise set up and the spacing layer is applied thereover.

In a related aspect, a preferred manner of securing the spacing layer to the bottom substrate is the use of an adhesive. In addition to securing the layers together, it has been found that the adhesive will sufficiently engage with the reagent

composition as to help to seal the space between the bottom substrate and the spacing layer. The adhesives preferably placed on the spacing layer, which is laminated onto the base substrate. The adhesive thereby contacts the portion of the reagent which extends under the spacing layer.

5 In a further aspect, a preferred embodiment is described in which the analyte is glucose. In the case of glucose, the active components of the reagent composition will typically include an oxidoreductase, such as an enzyme for glucose; optionally a co-enzyme or co-factor; and a redox mediator. These components are typically dissolved or suspended in a matrix. The liquid test sample hydrates or dissolves the
10 matrix, and the analyte diffuses through the matrix to react with one or more of the active components. Typically, the enzyme oxidizes the glucose in the test sample to gluconolactone and/or gluconic acid. The mediator, in turn, reacts with or oxidizes the reduced enzyme, and consequently the mediator is reduced in the process. The reduced mediator can be detected at one of the electrodes on the test strip.

15 In a specific example of an oxidation/reduction reaction scheme useful for detecting glucose in human blood, a test sample containing glucose reacts with an enzyme such as Glucose-Di-Oxidoreductase (Gluc-Dor), and optionally a co-enzyme or cofactor such as pyrrolo-quinoline-quinone (PQQ), in the presence of a redox mediator. The mediator may include, for example, benzoquinone, transition
20 metal complexes, e.g., potassium ferricyanide, osmium derivatives (e.g., osmium bipyridyl complexes such as described in WO 98/35225) and nitrosoaniline derivatives (see U.S. Patent No. 5,286,362). This produces the oxidized form of the analyte, gluconolactone, and the reduced form of the redox mediator. The mediator thereafter shuttles the redox equivalent of mediator product, the reduced mediator, to
25 the electrode surface by diffusion. There the mediator is oxidized quantitatively at a defined anodic potential, and the resulting current is related to the apparent glucose concentration.

A representation of the reaction sequences for this reaction system using a nitrosoaniline derivative is provided below in Equation 1.

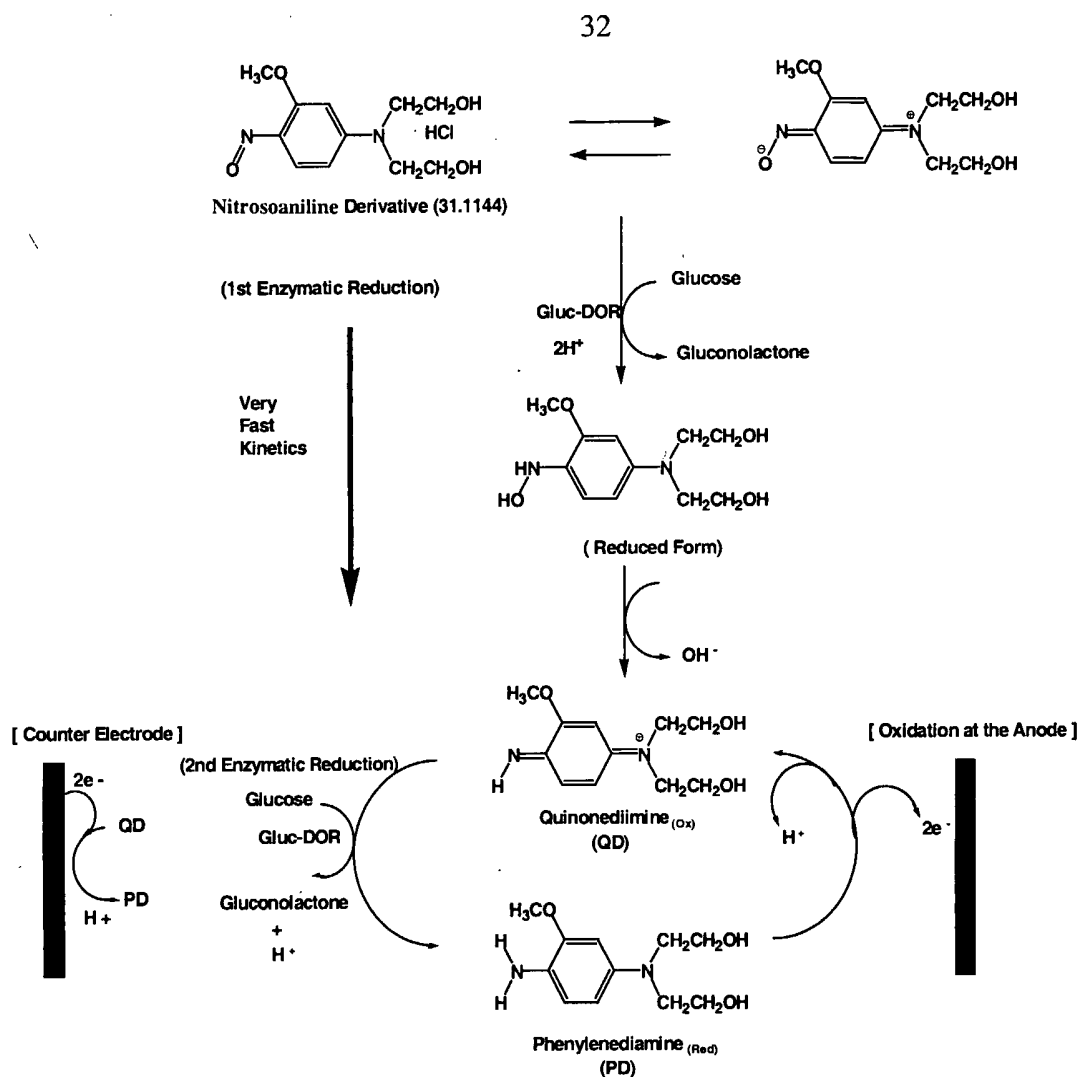

File = Mediator 311144 RXN Rev 09092002-Text.CDX

Synthesis of *o*-methoxy-[*N,N*-bis-(2-hydroxyethyl)]-*p*-nitrosoaniline

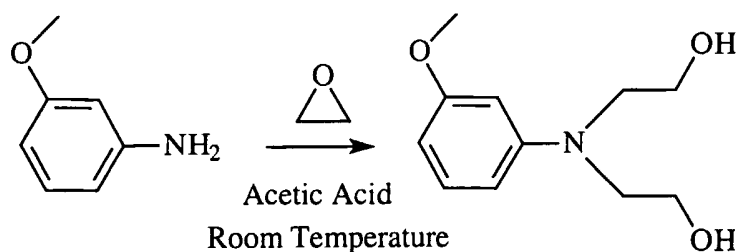

The compound is synthesized by methods known in the art. (See, e.g., U. S. Patent No. 5,286,362). To synthesize the intermediate *m*-methoxy (N, N-bis (2-hydroxyethyl)] aniline shown above, *m*-methoxy-aniline is dissolved in 500 ml 4N acetic acid. The mixture is cooled with a cold bath to 0°C while stirring, and 70.5 g, 5 i.e., ca. 79 ml (1.6 moles) of ethylene oxide is added drop-wise within five minutes at 0°-10°C. After leaving the mixture stand for 12 hours at room temperature, 500 ml water is added and the solution is neutralized by stirring and carefully adding a total of 200g NaHCO₃ in small portions.

Afterwards, the liberated base is extracted with 500 ml of methylene 10 chloride, shaken again three times with 250 ml methylene chloride each time. The organic phases are combined, dried over sodium sulphate, aspirated and concentrated in a vacuum. The intermediate is obtained by Thin Layer Chromatography (TLC) silica gel 60 plate from Merck. The mobile phase is toluene/acetone in a ratio of 5:2.

15 Synthesis and recovery of the final product.

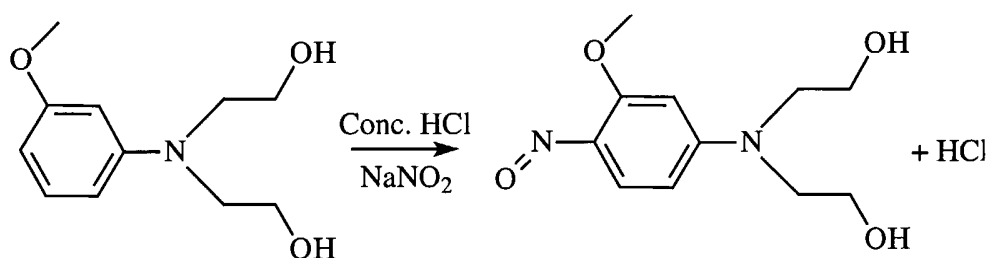

Next, 140 ml of concentrated hydrochloric acid and 140 ml of water are filled into a 2-l three-neck flask equipped with a stirrer, dropping funnel and thermometer. The flask and contents are cooled to about -5°C with a dry ice bath, 20 and about 0.8 moles of the intermediate is then added to the flask drop-wise. The

intermediate (*m*-methoxy (N, N-bis (2-hydroxyethyl)] aniline) is added within a ten-minute period and the temperature is held constant over the entire time. The mixture is stirred for an additional 15 minutes. Next, a solution of about 0.87 moles of sodium nitrite in a volume of 120-ml water is added to the mixture at 0°C.

5 The mixture is stirred for an additional 30 minutes at 0°C. Subsequently, the mixture is diluted by the addition of 500 ml of water; then 218 ml of concentrated aqueous ammonia solution is added drop-wise while cooling on ice. The temperature of the mixture is not allowed to rise above 15°C while the ammonia is being added. Liberated nitroso base is extracted five times with 400 ml of n-butanol
10 and the solvent is distilled off in a rotary evaporator until an oily compound is obtained.

The oil is mixed with a mixture of 250 ml toluene/acetone=1:1 in order to remove inorganic products. The insoluble portion is aspirated and washed with 50 ml toluene/acetone=1:1. The inorganic material remains as a residue. The filtrate is
15 purified chromatographically on a silica gel 60 column (7.5 cm in diameter, filling level 90 cm, separating fluid toluene/acetone=1:1). A nitroso base in the form of an oil is obtained. This is dissolved in 600 ml of acetone and reacted drop-wise with 250 ml of saturated ethereal hydrochloric acid. After stirring for 30 minutes while cooling on ice the crystals which form are aspirated, washed three times with 100 ml
20 acetone and dried in a vacuum at room temperature over diphosphorus pentoxide.

The purity of the named compound is determined by TLC using a silica gel 60 plate from Merck. The mobile phase is toluene/acetone (1:1). The final product may also be further purified to analytical-reagent purity by means of re-

crystallization out of a small quantity of hydrochloric-acid water solution at low temperature.

As shown, the nitrosoaniline derivative, *o*-methoxy-[N,N-bis-(2-hydroxyethyl)]-*p*-nitrosoaniline, initially exists as a mixture of two isomers, or
5 tautomers, in equilibrium with each other. Reaction of Gluc-Dor with glucose in the test sample yields gluconolactone and the reduced form of Gluc-Dor (Gluc-Dor·2H⁺). The reduced form of Gluc-Dor (Gluc-Dor·2H⁺) reacts rapidly with the nitrosoaniline derivative, which is reduced and which regenerates Gluc-Dor. The reduced nitrosoaniline derivative then undergoes hydrolysis to form quinonediimine
10 (QD). In a second enzymatic, redox reaction, Gluc-Dor reacts with glucose to yield another molecule of Gluc-Dor·2H⁺ and gluconolactone. The Gluc-Dor·2H⁺ reacts with (is oxidized by) quinonediimine to regenerate Gluc-Dor, and produces a phenylene diamine derivative (PD). PD is then oxidized at the working electrode to produce a current related to glucose concentration. Additionally, at the counter
15 electrode QD can be reduced to PD.

Adjuvants.

With such small dimensions for the sample-receiving chamber, the characteristics of the reagent layer can have a significant impact on the operation of the test strip, particularly in view of hydration and mixing characteristics. The
20 control and reproducibility of the quantity, location, width, thickness, and other properties of the reagent layer become more important as the chamber volume decreases and test time diminishes. It is therefore desirable for the composition to include materials that specifically enhance the physical characteristics, such as the uniformity and flatness, of the applied layer. Additionally, the method of
25 application can impact the physical characteristics, control, and reproducibility of the reagent layer.

The reagent composition can therefore also include a variety of adjuvants to enhance the reagent properties or characteristics. For example, the composition may include adjunct materials to facilitate the placement of the reagent composition onto
30 the test strip and to improve its adherence to the strip. The composition can also include materials to increase its rate of hydration and/or its increase its influence on

the capillary action to fill the chamber with the test sample. Examples of adjunct materials to be used with the reagent composition include thickeners, viscosity modulators, film formers, stabilizers, buffers, detergents, gelling agents, fillers, film opening agents, coloring agents, and agents endowing thixotropy.

5 The adjuvant materials or components can impact the application, reproducibility and physical properties of the reagent layer. The adjunct materials can include one or more of the following:

 Thickeners may include, for example, (1) starches, gums (e.g., pectin, guar gum, locust bean (carob seed) gum, konjac gum, xanthan gum, alginates, and agar),
10 casein, gelatin, and phycocolloids; (2) cellulose and semi-synthetic cellulose derivatives (carboxymethyl-cellulose, methyl cellulose, hydroxymethylcellulose, hydroxyethylcellulose, methylhydroxyethylcellulose); (3) polyvinyl alcohol and carboxy-vinylates; and (4) bentonite, silicates, and colloidal silica. Preferred
15 thickeners include a combination of a xanthan gum sold under the trade name Keltrol F by CP Kelco US, Inc., and carboxymethyl cellulose sold under the trade
name AQUALON® CMC 7F PH by Hercules Inc., Aqualon Division.

 Film forming and thixotropic agents useful in the reagent composition include polymers and silica. Preferred thixotropic agents include silica sold under the trade name Kieselsäure Sipernate FK 320 DS by Degussa AG. Preferred film
20 forming agents include polyvinylpyrrolidone, sold under the trademark polyvinylpyrrolidon Kollidon 25, by BASF, and polyvinyl propionate dispersion.

 Stabilizers for the enzyme in the reagent can be selected from sacchhrides and mono-or di-fatty acid salts. Preferred stabilizers include trehalose sold under the trade name D-(+)-Trehalose dihydrate by Sigma Chemical Co. and sodium
25 succinate.

 Detergents can be selected from water-soluble soaps, as well as water-soluble synthetic surface-active compounds such as alkali, earth alkali or optionally substituted ammonium salts of higher fatty acids, e.g., oleic or stearic acid, mixtures of natural fatty acids, for example, from coconut or tallow oil, fatty sulphates, esters
30 of sulphonic acids, salts of alkyl sulphonic acids taurine salts of fatty acids, fatty acid amides, and ester amides. Preferred detergents for the present invention include

an ester amide, *n*-octanoyl-*N*-methylglucamide, sold under the trade name Mega-8 by Dojindo Molecular Technologies, Inc., and a fatty acid salt, *N*-methyl oleyl taurate sodium salt, sold under the trade name Geropon T77 by Rhodia HPCII (Home, Personal Care and Industrial Ingredients).

- 5 It should be understood that one or more of the specific additives above described can exhibit additional properties and consequently could be categorized in one or more of the classes above noted.

Mediator.

- 10 A mediator for use in the reagent composition can be selected as any chemical species (generally electroactive) which can participate in a reaction scheme involving an enzyme, an analyte, and optionally a cofactor, and reaction products thereof, to produce a detectable electroactive reaction product. Typically, participation of the mediator in the reaction involves a change in its oxidation state (e.g., a reduction), upon interaction with any one of the analyte, the enzyme, or a
- 15 cofactor, or a species that is a reaction product of one of these (e.g., a cofactor reacted to a different oxidation state). A variety of mediators exhibit suitable electrochemical behavior. A mediator can preferably also be stable in its oxidized form, may optionally exhibit reversible redox electrochemistry, can preferably exhibit good solubility in aqueous solutions, and preferably reacts rapidly to produce
- 20 an electroactive reaction product. Examples of suitable mediators include benzoquinone, meldola blue, other transition metal complexes, potassium ferricyanide, osmium derivatives (see WO 98/35225) and nitrosoaniline-based mediators (see US Patent 5,286,362). In a preferred embodiment, the reagent composition utilizes a nitrosoaniline-based chemistry.

- 25 Preferred mediators include *N*-(2-hydroxyethyl)-*N'*-*p*-nitrosophenyl-piperazine, *N,N*-bis-(2-hydroxyethyl)-*p*-nitrosoaniline, *o*-methoxy-[*N,N*-bis-(2-hydroxyethyl)]-*p*-nitrosoaniline, *p*-hydroxynitrosobenzene, *N*-methyl-*N'*-(4-nitrosophenyl)-piperazine, *p*-quinone dioxime, *N,N*-dimethyl-*p*-nitrosoaniline, *N,N*-diethyl-*p*-nitrosoaniline, *N*-(4-nitrosophenyl)-morpholine, *N*-benzyl-*N*-(5'-
- 30 carboxypentyl)-*p*-nitrosoaniline, *N,N*-dimethyl-4-nitroso-1-naphthylamine, *N,N*,3-trimethyl-4-nitrosoaniline, *N*-(2-hydroxyethyl)-5-nitrosoindoline, *N,N*-bis-(2-hydroxyethyl)-3-chloro-4-nitrosoaniline, 2,4-dimethoxy-nitrosobenzene, *N,N*-bis-(2-

methoxyethyl)-4-nitrosoaniline, 3-methoxy-4-nitrosophenol, N-(2-hydroxyethyl)-6-nitroso-1,2,3,4-tetrahydroquinoline, N,N-dimethyl-3-chloro-4-nitrosoaniline, N,N-bis-(2-hydroxyethyl)-3-fluoro-4-nitrosoaniline, N,N-bis-(2-hydroxyethyl)-3-methylthio-4-nitrosoaniline, N-(2-hydroxyethyl)-N-(2-(2-methoxyethoxy)-ethyl)-4-nitrosoaniline, N-(2-hydroxyethyl)-N-(3-methoxy-2-hydroxy-1-propyl)-4-nitrosoaniline, N-(2-hydroxyethyl)-N-(3-(2-hydroxyethoxy)-2-hydroxy-1-propyl)-4-nitrosoaniline, N-(2-hydroxyethyl)-N-(2-(2-hydroxyethoxy)-ethyl)-4-nitrosoaniline. Particularly preferred mediators according to the present invention include N,N-bis-(2-hydroxyethyl)-*p*-nitrosoaniline, *o*-methoxy-[N,N-bis-(2-hydroxyethyl)]-*p*-nitrosoaniline, and N-(2-hydroxyethyl)-N-(2-(2-hydroxyethoxy)-ethyl)-4-nitrosoaniline.

An exemplary reagent composition is listed below in Table I. Other exemplary compositions are disclosed in the Homogeneous Reagent Stripes application, which was incorporated by reference above.

Table I

Components	Function	Amount Abs.	%solids w/w.	Note.
Keltrol F	Thickener	11.60 g	0.24%	
Carboxy methylcellulose	Thickener	27.24 g	0.57%	
Kieselsäure Sipernat 320 DS	Film Opener	97.01 g	2.01%	
Polyvinylpyrrolidone PVP K25	Film Former	89.33 g	1.85%	
Propiofan	Film Former	257.09	5.34%	
GlucDOR	Apo-Enzyme	19.127 g	0.40%	0.673 MU/g
pyrrolo-quinoline quinine (PQQ)	Co-Factor	0.5329 g	0.01%	
Na-Succinate	Stabilizer	23.23 g	0.48%	
Trehalose	Stabilizer	23.6 g	40.49%	
KH ₂ PO ₄	Buffer	12.02 g	0.39%	
K ₂ HPO ₄ x 3 H ₂ O	Buffer	43.43 g	0.90%	
Nitrosoaniline	Mediator	41.26 g	0.86%	
Mega 8	Detergent	13.23 g	0.27%	
Geropon T77	Detergent	1.405 g	0.03%	
KOH 5N	Adjust Buffer	36.47 g	0.76%	
Water total		4114.52 g		
Sum		4817.80 g		
Solids			14.6%	

Mixing.

The components of the reagent composition are admixed with water to provide a homogeneous, viscous suspension. The order of addition is not critical for the invention. A sufficient amount of the buffer solution is added to maintain the reagent composition at a pH of about 7. Typically the selected components are pre-mixed with water to provide a variety of stock solutions that can be combined to yield the final reagent composition. For example, a buffer solution can be prepared by combining the phosphate salts and, optionally, the sodium succinate. Other stock solutions include: the thickening agents, i.e., Keltrol F and the carboxymethyl cellulose; the surfactants, i.e., Geroxon T77 and Mega 8; the enzyme and co-enzyme or cofactor; and the mediator.

The following provides an example of the preparation of a reagent composition. The reagent composition can be prepared by first preparing the following stock solutions:

Buffer Solution	pH 6.9 to 7.1
	Amount (gm)
H ₂ O	1214.62
KH ₂ PO ₄	18.27
K ₂ HPO ₄	43.43
Na succinate	23.23

Keltrol F Solution	
	Amount (gm)
H ₂ O	287.06
Buffer Solution	101.35
Keltrol F	11.60

Carboxymethylcellulose (CMC) Solution

	Amount (gm)
H ₂ O	1334.76
Na CMC ¹	27.24

1. Na CMC is a sodium salt of carboxymethyl cellulose sold by Hercules Inc.,

Aqualon Division

Silica Suspension

	Amount(gm)
H ₂ O	722.99
Sipernat 320 ¹	

¹ Kieselsäure Sipernat 320 DS (Silica) sold by Degussa AG.

Polyvinylpyrrolidone (PVP) Solution

	Amount (gm)
Buffer Solution	226.03
Mega 8 ¹	13.23
Geropon T77 ²	1.405
PVP ³	89.33

- 5 1. Mega 8 is n-octanoyl-N-methylglucamide sold by Dojindo Molecular Technologies Inc.
2. Geropon T77 is N-methyl oleyl taurate sodium salt sold by Rhodia HPCII.
3. PVP is Polyvinylpyrrolidone K25 sold by BASF.

10 Trehalose Solution¹

	Amount (gm)
H ₂ O	36.4
Trehalose	23.6

¹ This trehalose solution is used only in preparing the "Enzyme Solution" listed below.

PQQ Solution

	Amount (gm)
Buffer Solution 1 st addition	101.59
PQQ	0.533
Buffer Solution 2 nd addition	30.0

Enzyme Solution	
	Amount (gm)
PQQ Solution	132.12
Gluc-Dor (673 U/mg Ly)	19.13
Trehalose Solution	58.75
Mediator Solution	
	Amount (gm)
Buffer Solution	782.27
Mediator	41.26
5 N KOH	36.47

- 5 The buffer solution, Keltrol F solution, CMC solution, and the Silica suspension were prepared a day before. These solutions can then be combined as listed below to prepare the reagent composition.

Final Reagent Composition

Thickener I (Keltrol F solution)	331.51 g
Thickener II (CMC Solution)	1262.9 g
PVP Solution	315.05 g
Silica suspension	762.3 g
Propiofan solution	257.09 g
Mediator Solution	855.84 g
Enzyme Solution	196.65 g
5N KOH	as required to achieve final pH of 6.9 to 7.1
Water (bidistilled)	518.69 g

- 10 For this reagent prior to coating, the final pH was 6.96 and did not need adjustment with 5N KOH solution. The measured viscosity was 111 mPas, which is in the correct range for coating of 105 to 115 mPas.

- 15 FIGS. 5 and 5A present a flow chart illustrating a preferred process 100 for preparing a test strip useful in accordance with the present invention. Process 100 begins in the central process line 101 at stage 102 with selection of a film material for the base layer or base substrate. In a preferred embodiment, the film is provided as a continuous roll having a width and length suitable for fabricating a large

number of test strips. In subsequent finishing steps, the processed film can be subdivided to provide a single strip or web having a width that approximates the length of the test strip and includes a series of test strips, or can be die cut to provide individual test sensors.

5 From stage 102, the film proceeds to stage 104 where it is pretreated to receive a metal coating and is coated with the metal in one continuous process. The pretreatment can be used to clean or modify the surface to provide a uniform coating thickness and better adhesion of the subsequent metallized layer. The pretreatment can include subjecting the film to corona discharge or Argon plasma. Immediately
10 after this pre-treatment, a uniform conductive coating is applied to the film as shown at 106. Alternatively, suitable substrates with metal coatings can be obtained commercially.

The metallic layer may contain pure metals, alloys, or other materials, which are metallic conductors. Examples of metals or metallic-like conductors include:
15 aluminum, carbon (such as graphite), cobalt, copper, gallium, gold, indium, iridium, iron, lead, magnesium, mercury (as an amalgam), nickel, niobium, osmium, palladium, platinum, rhenium, rhodium, selenium, silicon (such as highly doped polycrystalline silicon), silver, tantalum, tin, titanium, tungsten, uranium, vanadium, zinc, zirconium, mixtures thereof, and alloys or solid solutions of these materials.
20 Preferably, the materials are selected to be essentially unreactive to biological systems; such materials include: gold, platinum, palladium, iridium, or alloys of these metals. The metallic layer may be any desired thickness.

The conductive coating is preferably a metal layer that is applied by a variety of methods, including but not limited to sputtering, physical vapor deposition
25 (PVD), plasma assisted vapor deposition (PAVD), chemical vapor deposition (CVD), electron beam physical vapor deposition (EBPVD), and/or metal-organic chemical vapor deposition (MOCVD). Vapor deposition is typically performed under vacuum. These techniques are well known in the art and can be used to selectively provide a uniformly thin coating of metal onto a substrate. The resulting
30 metallized film can be inspected to ensure that the metal coating is uniform and free of material defects.

The roll of metallized film next encounters stage 108 where it is subdivided and/or sized to provide webs having a width that approximates the final length of an individual test strip. The slicing can be accomplished using fixed-knife slitting equipment well-known in the art.

5 A single web proceeds to stage 110 for patterning the electrodes, traces, and contacts or pads. At this stage, the electrodes, traces, and contact pads are formed by removing metal from the surface of the web strip. The excess metal can be removed using a variety of techniques well known in the art. At this stage, one or more indexing or registration marks can be formed either on a first edge proximate
10 to the electrodes, the opposite second edge proximate to the electrode pad, on both edges or anywhere in between. The indexing marks, particularly those at an edge, can be used in subsequent operations to align layered components prefabricated in separate operations.

In a preferred method, the metal is laser ablated to eliminate undesired
15 portions of the metal and leave the desired electrical components. In accordance with this method, selected areas are laser etched simultaneously, in a "broad field", as opposed to using linear movement of a focused laser beam. This broad field laser ablation method provides a precise metal pattern rapidly and at reduced cost as compared to other approaches. Corona treatment of the patterned substrate is then
20 conducted at stage 111.

The patterned web continues on to stage 112, where a reagent layer is deposited onto the electrodes. In a preferred embodiment, the reagent layer is deposited as a continuous elongate stripe extending adjacent or close to the first edge, and overlying the measuring electrodes formed on the patterned web. As
25 previously noted, the reagent is consequently located across the full width of the test strip, including the area laterally outside of the sample-receiving chamber and between the base substrate and the spacing layer. Also as noted, this will facilitate the drying of the reagent without discontinuities, edge effects, or other variances that would detract from providing a thin, flat, uniform reagent layer within the sample-
30 receiving chamber. The reagent includes a combination of components, and is formulated to dry rapidly with minimal or no running after deposition.

This stripe may be applied in any suitable fashion which provides the desired extent and uniformity of thickness, precision of the stripe edge, homogeneity, and the like. Preferred methods are capable of applying the desired coating at relatively high speed and high batch size. Suitable methods of application are well known in the art and therefore are not detailed herein.

Preparing the Spacing Layer

Referring now to process line 114, a process flow for preparing the spacing layer is illustrated. Beginning at stage 116, a material is selected to prepare a spacing layer for laminating on top of the reagent coated web prepared at stage 112.

10 The base film for the substrate can be selected from a variety of materials. The spacing layer material, similar to the base layer, can be provided as an elongate roll which can be conveniently processed rapidly and with high efficiency. Preferred materials include a polyester film sold under the trade name MELINEX® by DuPont. Other materials suitable for use in the present invention could include

15 PEN. The spacing layer material has a thickness specifically selected to provide a desired chamber depth (or height) in each of the test strips when combined with the thicknesses of any joining layers that are used to laminate the spacer to the other strip components. In preferred embodiments, the spacing layer is selected to have a thickness between about 75 μm and about 150 μm , more preferably from about 100

20 μm to about 125 μm . As noted above, the spacing layer can be formed of a double-sided adhesive.

The spacing layer is preferably formed as a continuous film having a series of gaps that will align with the electrodes on the bottom substrate webbing. The manner of joining the spacing layer and bottom substrate will impact the method for

25 preparing the spacing layer. For example, if the spacing layer is to be heat welded to the bottom substrate, then the spacing layer may simply be die cut to provide the appropriately spaced chamber gaps. However, a preferred method is the use of thin, non-interfering adhesives that join the adjacent layers. In accordance with this preferred method, a spacing layer is prepared for combination with the previously

30 described substrate webbing as set forth hereafter.

The spacing layer film is prepared having the desired width for combination with the remainder of the test strip components. The spacing layer film may include an opaque portion, e.g., a section 23 of it is printed blue or another color for use in visualizing the sample-receiving chamber, as described elsewhere. The
5 spacing layer film is laminated on the bottom side with a combination adhesive and release liner, and on the top side with a similar combination adhesive and liner.

At stage 118, two transfer adhesives are laminated to the spacing layer material: the first transfer adhesive is laminated to the top surface of the spacing layer, and the second transfer adhesive is laminated to the bottom surface of the
10 spacing layer. Preferably, the transfer adhesives are the same adhesive; however, in alternative embodiments, the first and second transfer adhesives can be different from each other. In preferred embodiments, the transfer adhesives are selected from commonly used and known adhesives, including pressure sensitive adhesives. Preferred adhesives exhibit sufficient hydrophobicity to prevent or inhibit the test
15 sample in the chamber from wicking out between the spacing layer and the reagent layer or base substrate. An example of a suitable sensitive adhesive is ARCare 90132 from Adhesives Research Inc. The adhesives are provided with a release liner to prevent premature adhesion of the spacing layer during processing. The release liners are disposed on the exterior surface of the first and second transfer
20 adhesives, facing outward from the spacing layer material.

The spacing layer with the adhesive release liners on the top and bottom surfaces progresses to stage 120. At stage 120, the cavity which will form the sample-receiving chamber is punched in the spacing layer. In one embodiment, the cavity is punched using a "kiss cut" method. The kiss cut method cuts through the
25 upper release liner, the upper adhesive, the spacing layer, and the lower adhesive, but not through the lower release liner. In subsequent operations, simply removing the lower release liner will then remove the punched out portions of the lower adhesive, the spacing layer, the upper adhesive, and the upper release liner from the punched spacing layer. In other embodiments, the cavity can be punched through
30 with a hollow die. The hollow die completely punches or cuts through the spacing layer, the two adhesives, and the two release liners, with the punched out portion subsequently removed in the hollow die. The spacing or pitch between each cavity

is determined and accurately controlled to allow accurate mating of the punched spacing layer over the electrodes using one or both of the indexing marks patterned in the reagent-coated web.

At stage 122, the lower release liner on the spacing layer is removed, taking
5 with it the kiss cut portions and exposing the adhesive on the underside surface of the spacing layer. Proceeding on to stage 124 in process line 101, the spacing layer is laminated over the reagent-coated web using one or more of the indexing marks previously patterned on the web to correctly align each cavity formed in the punched spacing layer directly on top of an electrode set to provide a web-spacing layer
10 laminate. At stage 126 in the central process line 101, the upper release liner covering the upper adhesive on the web-spacing layer laminate is removed in preparation for attaching the cover layer.

Laminating on the Cover Portions

At stage 128, a material for a body cover is introduced into the process. In
15 preferred examples, the material is a flexible polymeric material and may be selected, for example, MELINEX 454 or MELINEX 339 from du Pont. The material for the body cover is sized to have a width sufficient to overlay at least a portion of the electrode traces in the sample-receiving chamber of the test strip.

Referring now to process line 130, beginning at stage 131, a film material is
20 selected to provide a chamber cover over the cavity, reagent, and measuring electrodes on the web-spacing layer laminate. In preferred embodiments, the chamber cover material is provided as a clear poly(ethylene-terephthalate) (PET) or poly(ethylene-naphthalate) (PEN) film having a thickness between about 100 μm and about 200 μm . The coating may preferably include a release liner, which can be
25 removed immediately prior to laminating over the web-spacing layer. The chamber cover is preferably made from a hydrophilic material or the bottom surface of the chamber cover may be treated or coated to make it hydrophilic as indicated at 134. At stage 138, the film material can be sized to a desired width sufficient to form the chamber cover to overlay the cavity and electrodes.

30 Proceeding to stage 140, the body cover from stage 128 and the chamber cover from stage 138 are laminated to the web-spacing layer laminate. In preferred

embodiments, the body cover and chamber cover are simultaneously laminated with the web-spacing layer laminate. The body cover is positioned over a portion of the electrode traces proximate to the electrodes formed on the base substrate. The chamber cover is positioned over the cavity, reagent, and measuring electrodes on
5 the web-spacing layer laminate. The body cover and chamber cover are separated by a gap to form a vent at the interior end of the cavity formed in the test strip.

As described, the chamber cover is placed near the edge of the strip to overlie the cut out portion of the spacing layer, leaving the innermost portion of the cut out uncovered. As just described, this chamber cover preferably includes a
10 hydrophilic underside to promote the wicking of fluid into the reagent chamber. The chamber cover is spaced slightly from the body cover to form a gap which thereby communicates with the sample-receiving chamber and serves as a vent opening for air to escape as fluid enters the chamber, as described above.

The opacity of the spacing layer and the transparency of the chamber cover
15 cooperate to allow a user of the final test strip to better view the progress of a test. As constructed, the bottom substrate or reagent layer coated thereon is visible through the cut out in the spacing layer and through the transparent chamber cover. The bottom substrate and/or reagent has a light color, e.g., bright yellow, which contrasts with the opaque coloring of the spacing layer. Therefore, the progress of a
20 fluid through the capillary channel can be easily monitored by the person using the test. Further, since the slot 34 is configured to be hydrophobic on the body cover side and hydrophilic on the chamber cover side, fluid will abruptly stop when it reaches the slot, thus presenting a sharply defined fill-line which in turn provides a
25 clear indication to the user that sufficient fluid sample has been received into the chamber.

Separating the Test Strips

From stage 140, the finish processing steps for the fabrication of test strips are performed. At stage 142, a decision is made whether to manufacture a single, die-cut test strip similar to the single test strip 10 above discussed. If so, then the
30 multi-layered laminate from stage 142 proceeds to stage 144 to be die cut into single test strips.

Alternatively, the multi-layered laminate from stage 142 proceeds to stage 148, where it is kiss cut to define individual test strips and to perforate or weaken the boundaries between adjacent test strips on the ribbon. Additionally, at stage 149 the ends of the test strips are die cut along the laminated ribbon. One end of the web is
5 cut to form the fluid receiving end of the test sensor with a Y-shaped opening leading into the cavity. The test strips may be divided into cards comprising a number, e.g., 25, of strips which are only fence cut and then folded to be stacked in a vial or dispenser.

Proceeding out of either stage 144 or 149, the processed strips or ribbon of
10 strips are inspected and ultimately packaged for use by the consumer at stage 146 or 150, respectively.

FIGS. 6-16 illustrate in greater detail some of the components and/or process stages previously described with respect to FIGS. 5 and 5A. FIG. 6 illustrates a perspective view of one embodiment of a base film for use in forming the test strip.
15 Base film 160 is preferably provided as a flexible film or web material that is rolled onto one or more rollers 162 with processes 164, 166 proceeding on the material between the rollers.

The pretreated upper surface of the film is metallized using a sputtering, PVD, CVD, EBPVD, MOCVD or another suitable process, illustrated by reference
20 number 166 and described more fully above, to deposit a uniform coating of a metal or metal alloy. The processes can use a single or multiple target source for the metallic layer. The metallized film 168 can then be sectioned or subdivided into a plurality of metallized films, e.g., 170a, 170b, and 170c, by cutting or slicing the film as illustrated by reference number 172. Each separated roll of the conductive,
25 metallized film 170 can then be rolled upon a single core or upon a plurality of different cores as preferably desired.

The electrical components are formed from the conductive film, as shown in one embodiment in FIG. 7. The metallic surface of film 170 is treated to remove any metallic component that is not desired to form the electrodes, traces, contact
30 pads, or other intended features. This process can be precisely controlled using laser ablation or other technology. The process provides a plurality of sets of electrodes 182, traces 184, and contact pads 186. The process can also provide a plurality of

indexing or registration marks 176 along a first edge 178 and/or similar registration marks 177 along the opposite edge 180. As shown in FIG. 7, repeating features of the electrode pattern form registration markings 177. Preferably, each set of electrodes and/or contacts is associated with at least one index or registration mark, 5 176 and 177, respectively. After the electrode patterns are formed, the web can be rewound onto a roll for further processing, as described below.

FIG. 8 illustrates a portion of a reagent-coated web 188. The reagent composition is deposited on the surface of the flexible web material. The reagent layer 190 is deposited using a variety of coating methods including curtain coating, 10 hot melt coating, rotary screen coating, doctor blade or air knife coating, Meyer bar coating, and reverse roll coating techniques. Preferably, the reagent layer is deposited on the flexible web as a wet composition at a thickness of between about 50 μm and about 100 μm , more preferably, between about 60 μm and about 80 μm . Web 188 can be provided by coating a uniformly thin layer of reagent 190 directly 15 on top of electrode sets 182 and along the length of web 188 as a continuous narrow band 192. In preferred embodiments, the narrow band 192 has a width of between about 5 mm and 9 mm and a dry thickness of between about 2 μm and about 10 μm . As depicted in FIG. 8, the reagent layer 190 is translucent.

The reagent layer is preferably coated by a slot-die coating technique 20 illustrated in FIG. 8A, and also described in the Homogeneous Reagent Stripes application, incorporated by reference hereinabove. The polymer web 300 (Melinex® 329, DuPont) is moved into the coating area 302, containing a slot-die head 304 and a back up roller 306. A slot-die head suitable with the illustrated embodiment is available from Troller Schweizer Engineering (TSE), Murgenthal, 25 Switzerland, Part No. 113-10xx, although other slot-die heads could be used. In the illustrated embodiment, the slot-die head defines a rectangular channel through which the reagent is dispensed. The channel in the illustrated embodiment has a height of about 250 microns, a length of about 40mm, and a width of about 7mm. The angle α is about 35 degrees and the slot-die head is angled slightly with respect 30 to web 300 as shown by angle β . The angle α is determined experimentally and is a function of the degree of wrap of the web around the roller, coating characteristics,

and an optimum position for stable coating flow out of the slot-die head used. Preferably, the carriage that holds the slot-die head is positioned at either 35 degrees above the centerline of the back up roller or 55 degrees below the centerline of the back up roller on the coating system. As just mentioned, a second angle β angles an upstream land 305 and a downstream land 307 of the slot-die head 304 relative to the tangent to the back up roller 306. The second angle β is adjusted for optimum flow of the reagent coating out of the slot-die head 304. The preferred gap W between the slot-die head and the web is determined using TopCoat software from RheoLogic Ltd., Leeds, United Kingdom, which determines a coating window based upon rheology, coat weight, surface tension, desired web speed, back up roller radius, slot-die upper and lower land lengths, slot-die inlet gap and inlet length, and the angle of the upstream land relative to the downstream land.

In the illustrated embodiment, the slot-die head is zeroed to the web surface and adjusted to a slot to web gap shown as W in FIG. 8A of $74 \mu\text{m}$. Web speed is ramped up from 0 to 38 m/min for deposition of the coating onto the web. While in the illustrated embodiment only the web moves, it should be understood that the slot-die coating process could be reconfigured such that the slot-die head moves instead of or in addition to the web. The process could also be reconfigured such that α is 90 degrees and the reagent is dispensed downward onto the web. The reagent matrix can be delivered to the slot-die head 304 using a variety of means including gear pumps, pistons, syringes, bladder systems as are known in the art. The reagent delivery system is adjusted to a water flow of 13.58 ml/min to deliver a coat weight of 53 g/m^2 through the coating head. The width of the resulting coated stripe 192 (FIG. 8) is $7.0 \pm 0.3 \text{ mm}$. The coating is dried in the heated drying zone or dryer 308 (length 15 m, temperature $110 \text{ }^\circ\text{C}$, speed 38 m/min) and rewound on a spool 310 at the rewind station 312.

FIG. 9 is an exploded view of a spacing layer assembly 194, which can be assembled in accordance with the present invention. Spacing layer assembly 194 comprises a spacing layer 196 preferably formed of a polymeric material. Spacing layer 196 includes a band or section 197 that is colored (corresponding to section 23, FIG. 2). In the manufacturing process, spacing layer 196 is provided in a roll 198 and is then overcoated with adhesives on top and bottom.

The top adhesive is provided in a roll 200 which further comprises a top or “tight” release liner 202, which is adapted to withstand further processing, an adhesive 204, and a lower or “easy” release liner 206. Preferred adhesives 204 for use in the present invention include a pressure-sensitive adhesive sold under the trade name ARCare 90132 by Adhesives Research Inc. During assembly, bottom release liner 206 is removed and the resulting adhesive 208 having the top release liner 202 still present is adhered to spacing layer 196 as indicated in the top of FIG. 9.

Similarly, the bottom adhesive is provided in a roll 210 which further comprises a top or “tight” release liner 212, which is adapted to withstand further processing, an adhesive 214, and a lower or “easy” release liner 216. Preferred adhesives 214 for use in the present invention include a pressure-sensitive adhesive sold under the trade name ARCare 90132 by Adhesives Research Inc. During assembly, bottom release liner 216 is removed and the resulting adhesive 218 having its top release liner 212 facing away from spacing layer 196 is adhered to spacing layer 196 as indicated in FIG. 9. It should be understood that adhesive 204 can be the same or different from adhesive 214.

FIG. 10 illustrates spacing layer 196 that has been die cut to form pre-capillaries 220a, 220b, 220c, etc., and is ready to be laminated to a web of base substrate material 188 as described with reference to FIG. 8. Pre-capillaries 220 can be formed using a “kiss-cut” technique in which a die cuts through the top release liner 202, adhesive 204, spacing layer 196, and adhesive 214, but not release liner 212, which, as noted above, faces away from spacing layer 196. Release liner 212 is then removed along with portions of the top release liner 202, adhesive 204, spacing layer 196, and adhesive 214 that had been cut through. These portions that are cut through comprise “capillary trim,” i.e., a sandwich of layers shaped like pre-capillaries 220. This “trim” is removed along with release liner 212, leaving the cavities 220 devoid of any material. As release liner 212 is removed, it can be inspected to ensure that it always contains the capillary trim just described. The resulting series of cavities 220 are spaced from each other a desired distance selected to position each one of the channels of the series of channels 220 directly over a measuring electrode set in the test strip. The spacing layer 196 having its lower

adhesive exposed can then be aligned with web 188 by means of indexing marks 176 and laminated thereto. Each capillary channel of the series of channels 220 overlays one set of measuring electrodes 182.

FIG. 11 illustrates an assembly 230 formed by the lamination of spacing layer 196 to web 188. In FIG. 11, the upper release liner 202 has been removed from the top adhesive 208, which makes assembly 230 ready for assembly of additional material thereto. As shown in FIG. 12, a web 240 of chamber covering layer material and a web 234 of body covering material are aligned over the exposed upper adhesive 208 of assembly 230 and are ready to be adhered thereto. As depicted in FIG. 12, chamber covering layer 240 is clear and includes a hydrophilic coating (see coating 21, FIG. 2) on at least the side that faces cavities 220. This facilitates wicking or transport of the liquid sample into the sample-receiving chamber and over the electrodes and reagent layer. Body cover 234 is opaque, is colored as shown, and is preferably hydrophobic. Covering layer 240 and body cover 234 can be provided on reels like those described above with reference to FIG. 9. Preferably, chamber covering material 240 is slightly thinner than body covering material 234.

Assembly 260 shown in FIG. 13 is produced by laminating webs 234 and 240 to the assembly 230 shown in FIG. 12 and then trimming the end of the web to form dosing edge 250. Dosing edge 250 is preferably formed by a shear cut in which the cutting blade moves across the end of the web as indicated by arrow 252. By contrast, it is more difficult to use a die punching technique without damaging the capillaries. The shear cut along dosing edge 250 also cuts away a portion of the pre-capillaries 220 and defines the final volume of capillaries 222. Capillaries 222 preferably include a flared or Y-shaped opening as shown. Preferably, a gap 262 is formed between the chamber covering web and the body covering web and this gap will ultimately provide a vent opening in the individual test strips. In preferred embodiments, the gap has a width of between 1.0 mm and about 1.6 mm.

With further reference to FIG. 13, assembly 260 is ready for further processing as indicated by dashed lines 262 and 264. In FIG. 14 there is shown the kiss-cut strip 276 having a plurality of individual test strips, e.g., 278a, 278b, and 278c, detachably connected together. It can be observed that kiss-cut strip 276 has

been trimmed or cut at its upper end along lines 262 in FIG. 13 to have a profile and/or configuration suitable to facilitate capturing a very small fluid sample in each of the series of capillary channels 222. In the illustrated embodiment, kiss-cut strip 276 has a flat working end 280 exposing the end of the sets of Y-cut capillary channels 222. The resulting configuration of second edge 282 can be provided to facilitate insertion of a single strip into a meter (not shown). For example, the second edge 282 can have a registration mark and/or tabs, cut slots, or other configurations designed to allow insertion of a single strip into the meter in only one direction. For example, with reference to FIG. 13, the edges 177 of contact pads 288 are spaced by a constant pitch, "P" as shown, and edges 177 can therefore be used as registration marks. As in other processing steps, the indexing or registration marks 176 and 177 on either the first edge and/or the second edge can be used to accurately "kiss cut" and trim the individual test strips from the laminated structure 260.

FIG. 15 is a perspective view of one embodiment of a punched cut test strip 290 formed by cutting through the dashed lines 264 shown in FIGS. 13 and 14. Strip 290 illustrated in FIG. 15 has been substantially described above as test strip 10. Strip 290 is provided as an individual test strip separate from any other test strip.

Example

By way of specific example, a test strip is formed based on the described method and using materials as follows. The bottom substrate is surface coated with a 50 nm layer of gold, and is slit to widths of 43-45 mm. Laser ablation (308 nm) is performed using a field size of approximately 40 mm x 10 mm. The spacing layer assembly includes a spacing layer film of white Melinex™ 339, and a thickness of 0.1016 or 0.127 mm (4 or 5 mil). The bottom and top adhesives are an Adhesive Research Arcare 90132 adhesive at 0.0254 or 0.0127 mm (1 or ½ mil), sandwiched between release liners having a thickness of 0.0508mm (2 mil). The capillary channels are formed with a width of 1.500 mm, +/- 0.050 mm, and a pitch (spacing) of 9 mm, +/- 0.150 mm.

The body cover 18 comprises a strip of Melinex 454, 453 or 339 material, 0.127 mm (5 mil) thick. The chamber cover 20 comprises a polyester or polyethylene naphthate material formed, for example, from Melinex 454 or 453, 0.1016 mm (4 mil) thick. As indicated, the chamber cover may be preferably treated

or coated to have a hydrophilic underside adjacent to the capillary channel to promote wicking of the blood specimen into the channel. In a preferred embodiment, a Melinex 453 foil (4 mil) for chamber cover 20 is coated on its underside with a hydrophilic material 21, ARCare 90037 from Adhesives Research
 5 Inc. Preferably the chamber cover material is initially formed as a wider material, and is slit to the desired width after preparation.

Test Strip Examples

The following materials will be used in the strip:

	Base substrate layer 12	Melinex 329-9 mil or 329 – 10 mil
10	Conductive Layer 26	Sputtered gold – 50 nm
	Lower Adhesive Layer 49	AR ARCare 90132 PSA – 1 to 0.5 mil
	Spacing layer 14	Melinex 329 or 339 – 4 to 5 mil
	Adhesive Layer 46	AR ARCare 90132 PSA – 1 to 0.5 mil
	Body Cover 18	Melinex 339 or 329 or 454 – 5 mil
15	Chamber Cover 20	Melinex 339 or 329 or 454 – 4 mil
	Hydrophilic foil 21	ARCare 90037

Storage of Strips

Strips may be packaged in a variety of ways. For example, strips may be packaged into flip-top plastic vials (e.g., 10, 25 or 50 count). All containers include
 20 desiccant materials necessary to ensure acceptable shelf-life. Test strips preferably display a minimum shelf life of 18 months when stored between 4° - 32°C in tightly closed containers as provided.

While preferred embodiments incorporating the principles of the present invention have been disclosed hereinabove, the present invention is not limited to
 25 the disclosed embodiments. Instead, this application is intended to cover such departures from the present disclosure as come within known or customary practice in the art to which this invention pertains and which fall within the limits of the appended claims.

WHAT IS CLAIMED IS:

1. A test strip, comprising:
 - a base substrate having a working electrode and a counter electrode
 - 5 formed thereon and having two side edges and an end edge;
 - a spacing layer overlying the base substrate and having a void that at least partially defines a sample-receiving chamber;
 - a covering layer overlying the spacing layer; and
 - a reagent layer disposed in the sample-receiving chamber and
 - 10 covering a portion of the base substrate and at least one of the electrodes, the reagent layer extending under the spacing layer to the two side edges and being sandwiched between the spacing layer and the base substrate.
2. The test strip of claim 1, wherein the reagent layer extends to the end
- 15 edge of the base substrate.
3. The test strip of claim 2, wherein the reagent layer defines a reagent layer end edge that is aligned with the end edge of the base substrate.
- 20 4. The test strip of claim 2, wherein a sample-receiving opening of the sample-receiving chamber is disposed at the end edge of the base substrate.
5. The test strip of claim 1, wherein the reagent layer defines two reagent layer side edges that are aligned with the side edges of the test strip.
- 25 6. The test strip of claim 1, wherein the spacing layer comprises a unitary spacing layer.
7. The test strip of claim 1, wherein the spacing layer comprises an
- 30 adhesive material.

8. The test strip of claim 1, further comprising an adhesive layer disposed between the spacing layer and the base substrate.
- 5 9. The test strip of claim 8, wherein the adhesive layer is sandwiched between the spacing layer and the base substrate, the adhesive layer having an edge profile that is aligned with a peripheral edge of the sample-receiving chamber.
- 10 10. The test strip of claim 9, wherein the adhesive layer forms a seal around the periphery of the sample-receiving chamber.
- 15 11. The test strip of claim 1, wherein the test strip defines a central longitudinal axis and the sample-receiving chamber forms a channel oriented substantially parallel to the central longitudinal axis.
- 20 12. The test strip of claim 11, wherein the covering layer comprises a vent opening in communication with the sample-receiving chamber, the vent opening being positioned over a downstream portion of the sample-receiving chamber.
- 25 13. The test strip of claim 12, wherein the reagent layer extends to the downstream portion of the sample-receiving chamber over which the vent opening is positioned.
- 30 14. The test strip of claim 13, wherein the reagent layer extends beyond the downstream portion of the sample-receiving chamber over which the vent opening is positioned.
15. The test strip of claim 1, wherein the reagent layer has a thickness of between about 1 and 20 microns.

16. The test strip of claim 15, wherein the reagent layer has a thickness of between about 2 and 6 microns.
- 5 17. The test strip of claim 1, wherein the sample-receiving chamber has a height from about 50 μm to about 200 μm .
18. The test strip of claim 17, wherein the sample-receiving chamber has a height from about 120 μm to about 180 μm .
- 10 19. The test strip of claim 1, wherein the sample-receiving chamber has a volume of less than 1.0 μl .
20. The test strip of claim 1, wherein the sample-receiving chamber has a volume of less than 0.5 μl .
- 15 21. The test strip of claim 1, wherein the sample-receiving chamber has a volume from about 0.15 μl to about 1.4 μl .
22. The test strip of claim 21, wherein the sample-receiving chamber has a volume from about 0.4 μl to about 0.7 μl .
- 20 23. The test strip of claim 1, wherein the reagent layer has a uniform thickness, substantially devoid of a meniscus.
- 25 24. The test strip of claim 1, wherein the reagent layer includes one or more thickeners, viscosity modulators, film formers, stabilizers, buffers, detergents, gelling agents, fillers, film opening agents, coloring agents, and thixotropic agents.
- 30 25. The test strip of claim 1, wherein the reagent layer includes silica.

26. A test strip, comprising:
a test strip body having meter-insertion and sample-receiving ends,
first and second sides, and a central longitudinal axis disposed substantially
parallel to the two sides, the test strip body defining a downstream direction
from the sample-receiving end to the meter-insertion end;
5 a base substrate defining the bottom of the test strip body and having
an electrode formed thereon, the base substrate having edges aligned with the
sample-receiving end and the first and second sides of the test strip body;
a spacing layer overlying the base substrate and having a void that at
10 least partially defines a sample-receiving chamber; and
a reagent layer disposed in the sample-receiving chamber and
covering a portion of the base substrate and the electrode, the reagent layer
being sandwiched between the spacing layer and the base substrate and
extending to the first and second sides and the sample-receiving end of the
15 test strip body.
27. The test strip of claim 26, wherein the sample-receiving chamber
defines a channel aligned with the longitudinal axis, the channel terminating
at a sample-receiving opening disposed at the sample-receiving end, whereby
20 the reagent layer extends to the sample-receiving opening.
28. The test strip of claim 27, further comprising a covering layer
overlying the spacing layer, the covering layer comprising a vent opening in
communication with the sample-receiving chamber, the vent opening aligned
25 with the sample-receiving chamber at a location downstream of the sample-
receiving opening.
29. The test strip of claim 28, wherein the vent opening comprises a slot
formed in the covering layer.
30. The test strip of claim 28, wherein the reagent layer extends in the
30 downstream direction to the vent opening.

31. The test strip of claim 30, wherein the reagent layer extends in the downstream direction beyond the vent opening.
- 5 32. The test strip of claim 30, wherein the reagent layer extends in the downstream direction beyond the electrode.
33. The test strip of claim 32, wherein the electrode comprises a counter electrode and a working electrode.
- 10 34. The test strip of claim 26, wherein the reagent layer defines first and second reagent layer side edges that are substantially aligned with the first and second sides of the test strip and a reagent layer end edge that is aligned with the sample-receiving end of the test strip.
- 15 35. The test strip of claim 26, wherein the spacing layer comprises a unitary spacing layer.
36. The test strip of claim 26, further comprising an adhesive layer
20 disposed between the spacing layer and the base substrate.
37. The test strip of claim 36, wherein the adhesive layer is sandwiched between the spacing layer and the base substrate, the adhesive layer having an edge profile that is aligned with a peripheral edge of the sample-receiving
25 chamber.
38. The test strip of claim 37, wherein the adhesive layer forms a seal around the periphery of the sample-receiving chamber.
- 30 39. The test strip of claim 26, wherein the reagent layer has a thickness of between about 1 and 20 microns.

40. The test strip of claim 39, wherein the reagent layer has a thickness of between about 2 and 6 microns.

41. The test strip of claim 26, wherein the reagent layer includes silica.

5

42. A method of manufacturing a test strip having first and second sides, sample-receiving and meter insertion ends, and a central longitudinal axis extending between the two ends, the method comprising:

- 10 (a) providing a web of base substrate material having first and second web edges;
- (b) forming an electrode set on the web;
- (c) applying a stripe of reagent material to the web and covering at least one electrode of the electrode set with the stripe, the stripe being oriented substantially parallel to the first web edge; and
- 15 (d) cutting the test strip from the web, the cutting defining the first and second sides and the sample-receiving end of the test strip, wherein during the cutting a portion of the reagent stripe is cut and removed from the sample-receiving end of the test strip and further wherein the test strip comprises a reagent layer extending to the sample-receiving end and the first
- 20 and second sides of the test strip.

43. The method of claim 42, further comprising, after step (c):
providing a web of spacing material having a cavity formed therein;
aligning the cavity with the central longitudinal axis of the test strip
25 and then laminating the spacing material to the web of base substrate material; and

then performing step (d), wherein the cavity at least partially defines a sample-receiving chamber.

30 44. The method of claim 43, wherein an adhesive is used for the laminating of the web of spacing material to web of base substrate material.

45. The method claim 43, further comprising, after laminating the web of spacing layer material, aligning and then laminating a web of covering layer material over the web of spacing layer material.

5 46. The method of claim 45, wherein the covering layer material forms a vent opening that communicates with the sample-receiving chamber.

10 47. The method of claim 46, wherein the electrode set comprises a plurality of spaced electrode sets, the cavity comprises a plurality of spaced cavities, the central longitudinal axis comprises a plurality of spaced central longitudinal axes, and step (d) comprises making a plurality of cuts to form a plurality of the test strips.

15 48. The method of claim 47, wherein the cutting in step (d) further comprises forming sample-receiving openings on the sample-receiving ends, each sample-receiving opening leading into a respective cavity, the reagent layer of each test strip extending to the sample-receiving opening.

20 49. The method of claim 43, wherein the electrode set comprises a plurality of spaced electrode sets, the central longitudinal axis comprises a plurality of spaced central longitudinal axes; and step (d) comprises making a plurality of cuts to form a plurality of test strips.

25 50. The method of claim 43, wherein the reagent stripe is deposited on the web of base substrate as a wet composition at a thickness of between about $50\mu\text{m}$ and about $100\mu\text{m}$.

30 51. The method of claim 50, wherein the reagent stripe is deposited on the web of base substrate as a wet composition at a thickness of between about $60\mu\text{m}$ and about $80\mu\text{m}$.

52. The method of claim 50, wherein the reagent stripe dries to a thickness of between about $3\mu\text{m}$ and about $20\mu\text{m}$.

53. The method of claim 42, wherein step (c) comprises applying the reagent stripe by a slot-die coating process.

54. The method of claim 42, wherein the electrode set comprises a counter electrode and a working electrode, both of which are covered by the reagent stripe.

55. The method of claim 42, wherein the reagent stripe is continuous.

56. The method of claim 42, wherein the meter insertion end is located proximate the second edge of the web of base substrate material.

57. A test strip, comprising:
a base substrate having a reagent layer disposed thereon;
a covering layer overlying the base substrate; and
a sample receiving chamber disposed between the base substrate and the covering layer, the sample receiving chamber terminating in a sample receiving opening located at a dosing edge of the test strip; and
wherein the reagent layer extends beyond a periphery of the sample receiving chamber and extends to the dosing edge of the test strip.

58. The test strip of claim 57, wherein the dosing edge comprises an end of the test strip.

59. The test strip of claim 57, wherein the dosing edge comprises a side of the test strip.

60. The test strip of claim 57, wherein the covering layer comprises a

chamber cover and a body cover having a slot therebetween, the slot being in communication with the sample receiving chamber and defining a vent opening in the covering layer that allows air to escape as fluid enters the sample receiving chamber.

5

61. The test strip of claim 60, wherein the slot comprises a gap which spaces the body cover from the chamber cover.

10

62. The test strip of claim 61, wherein the gap extends across the width of the covering layer.

63. The test strip of claim 60, wherein the slot overlies the reagent layer.

15

64. The test strip of claim 57, further comprising an electrode disposed in the sample receiving chamber, the electrode being covered by the reagent layer.

20

65. The test strip of claim 57, further comprising a spacing layer disposed between the covering layer and the base substrate, the spacing layer defining a void portion that further defines the height and perimeter of the sample receiving chamber between the base and the covering layer.

25

66. The test strip of claim 65, wherein the reagent layer is sandwiched between the base substrate and the spacing layer.

67. The test strip of claim 66, wherein the reagent layer extends to a side edge and an end edge of the test strip.

30

68. The test strip of claim 57, wherein the dosing edge comprises an end of the test strip, and the reagent layer extends to both sides of the test strip.

69. The test strip of claim 57, wherein the reagent layer has a thickness of between about 2 and 6 microns.
- 5 70. The test strip of claim 57, wherein the sample-receiving chamber has a volume of less than 1.0 μl .
71. The test strip of claim 57, wherein the sample-receiving chamber has a volume of less than 0.5 μl .
- 10 72. The test strip of claim 57, wherein the sample-receiving chamber has a volume from about 0.15 μl to about 1.4 μl .
73. The test strip of claim 57, wherein the sample-receiving chamber has a volume from about 0.4 μl to about 0.7 μl .
- 15 74. The test strip of claim 57, wherein the reagent layer defines a reagent layer edge that is aligned with the dosing edge.
75. The test strip of claim 74, wherein the dosing edge comprises a side edge of the test strip.
- 20 76. The test strip of claim 74, wherein the dosing edge comprises an end edge of the test strip.

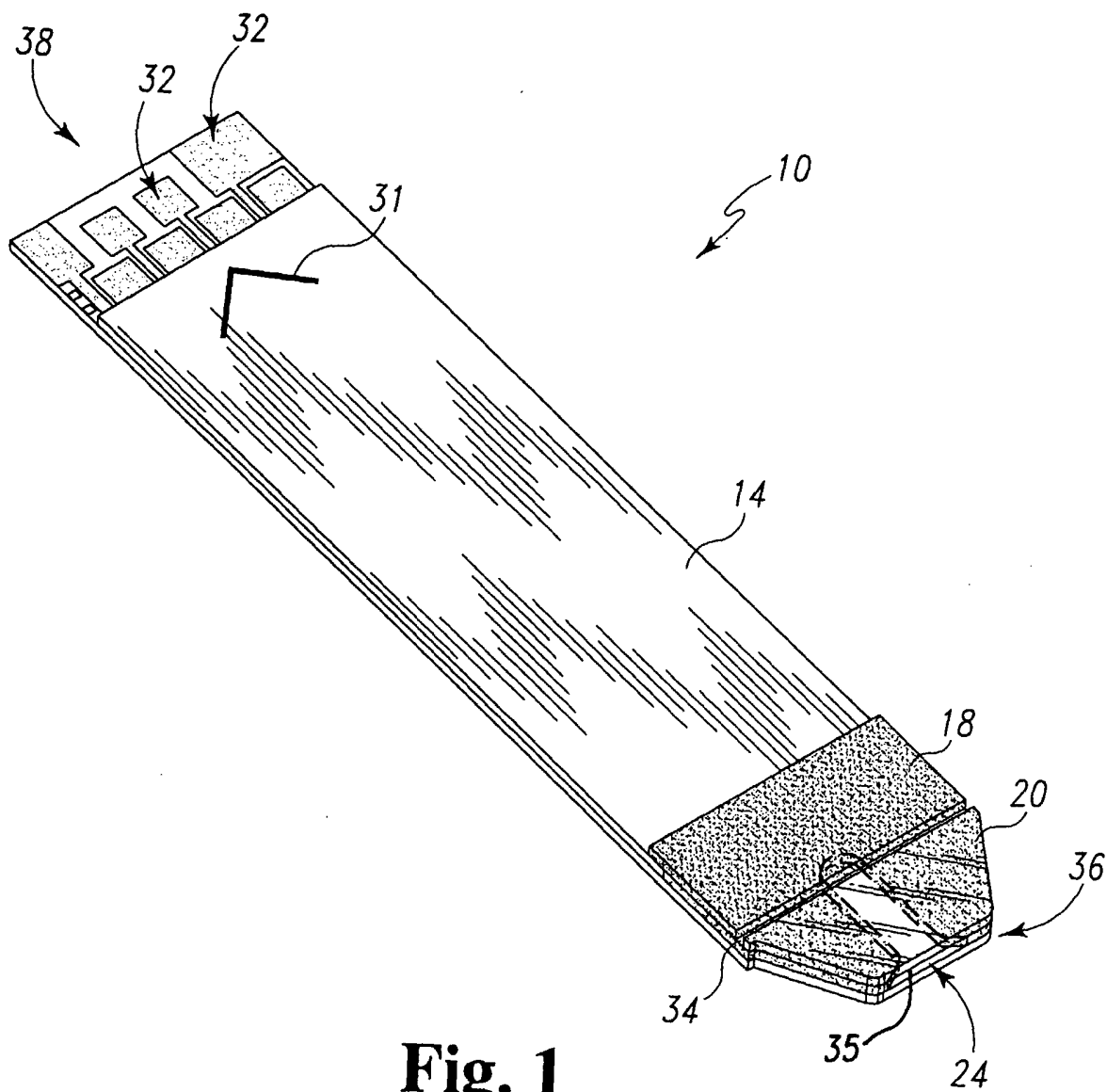

Fig. 1

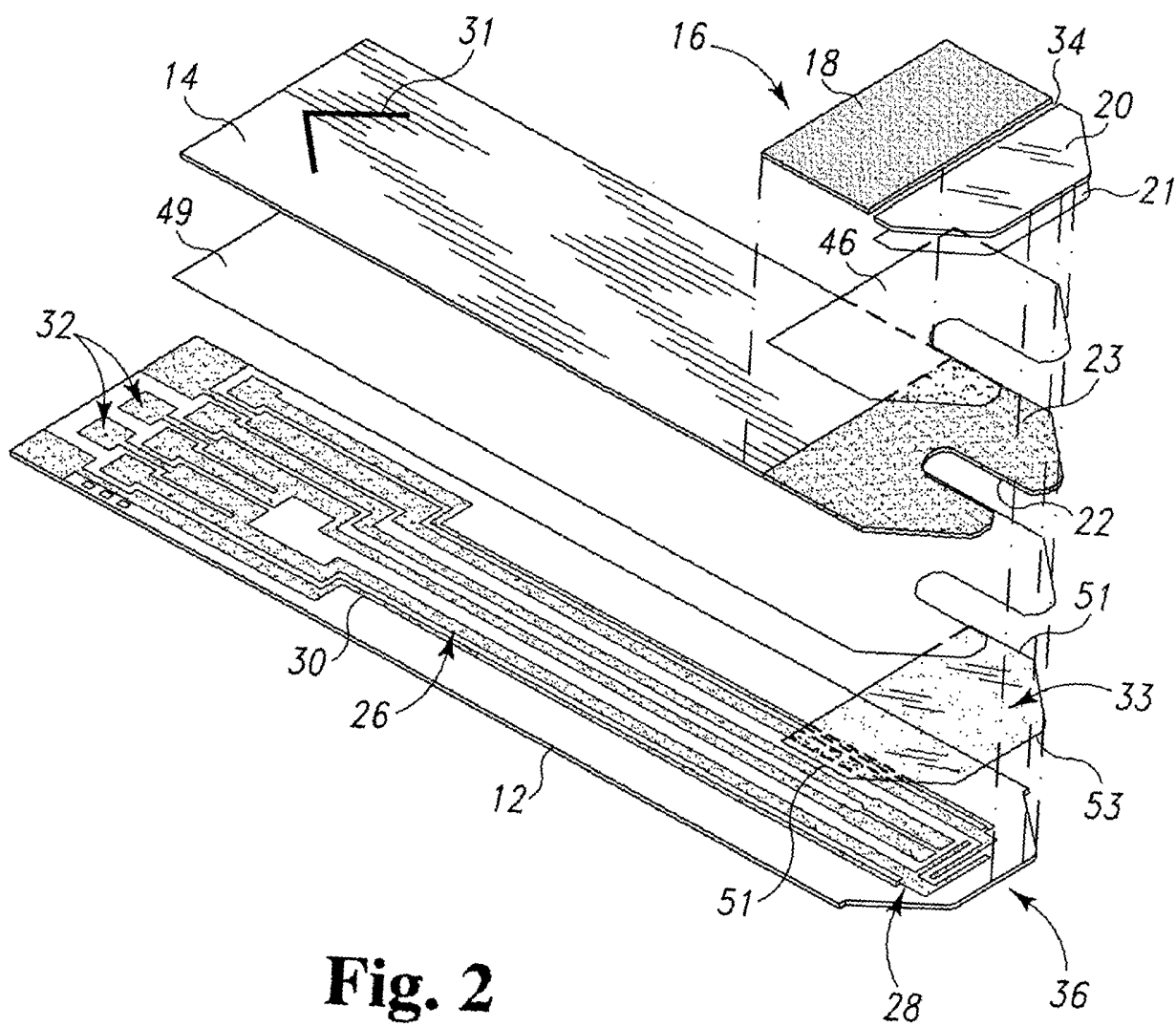

Fig. 2

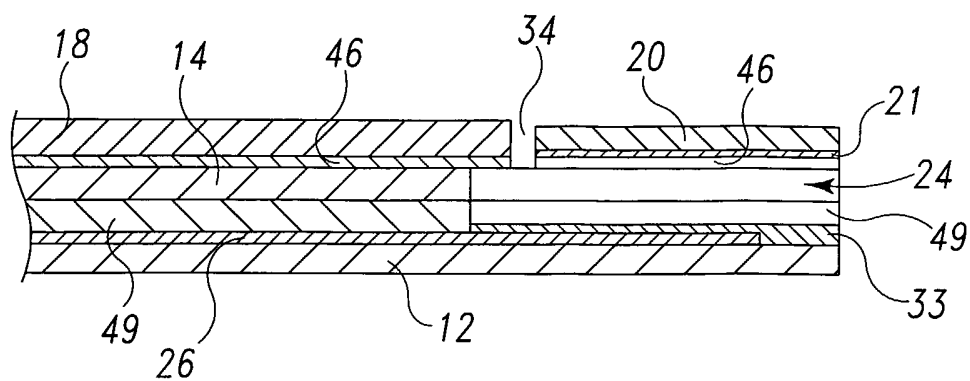

Fig. 3

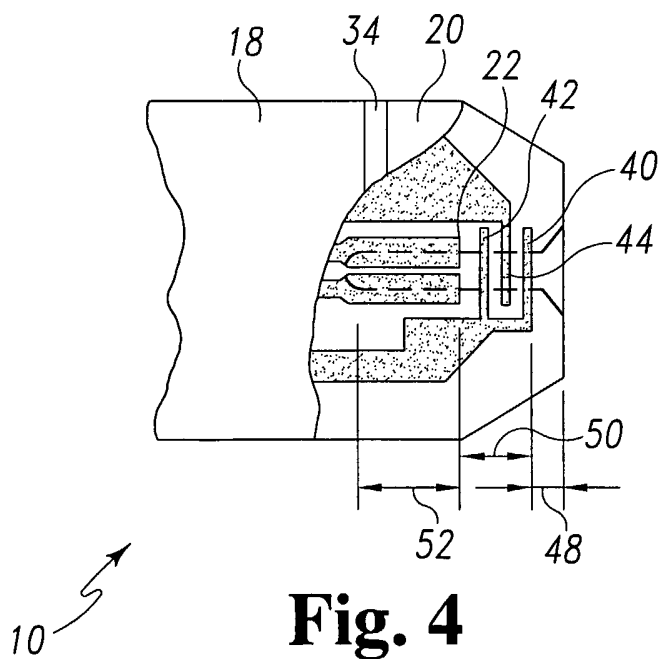

Fig. 4

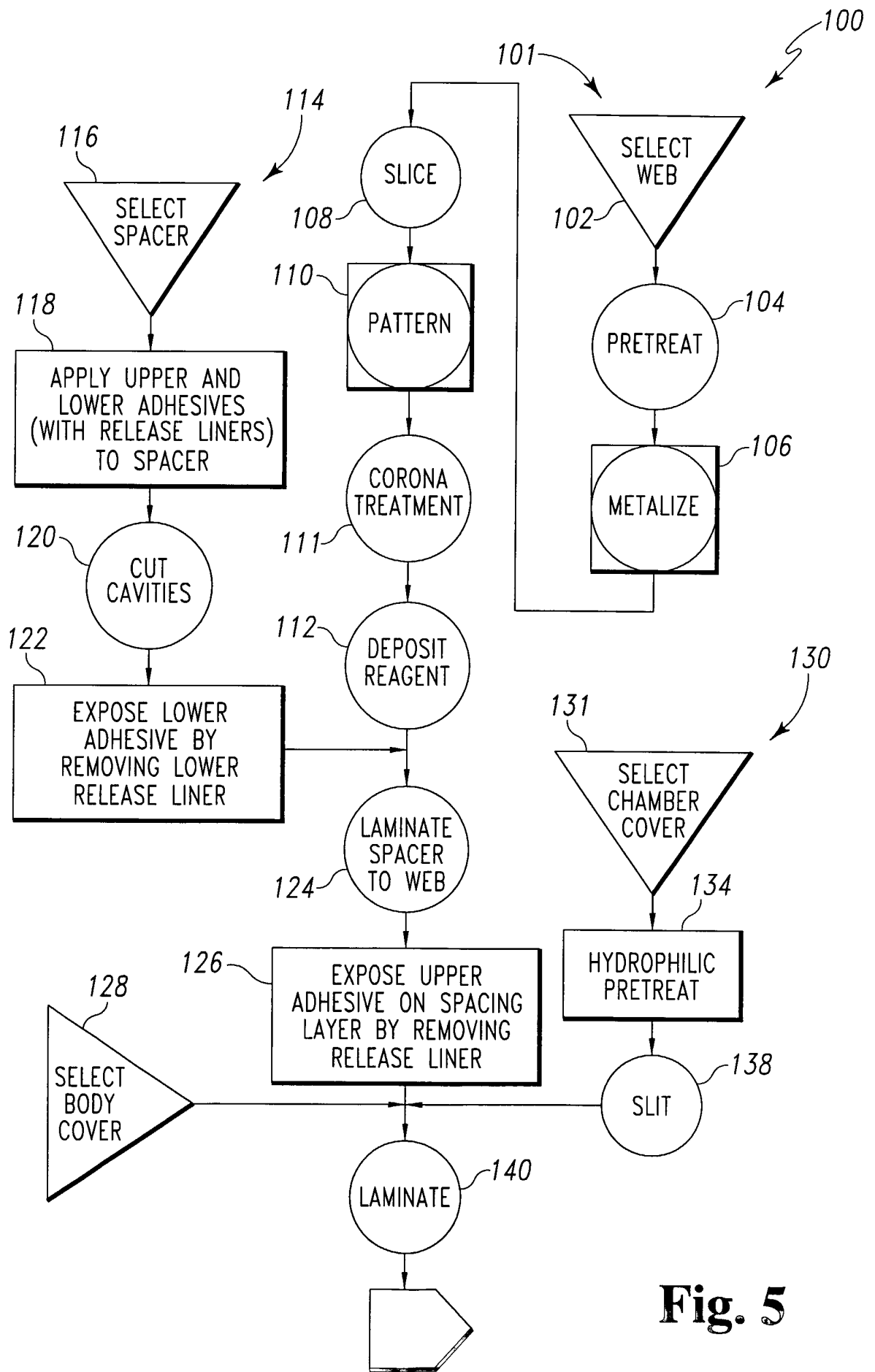

Fig. 5

100 (cont.)

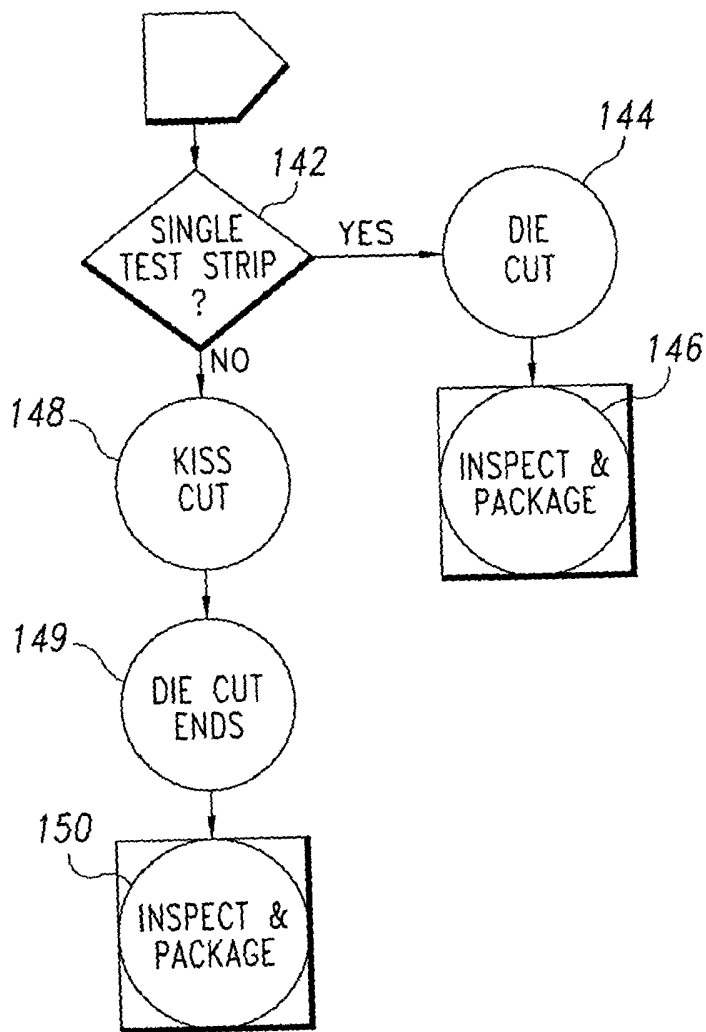
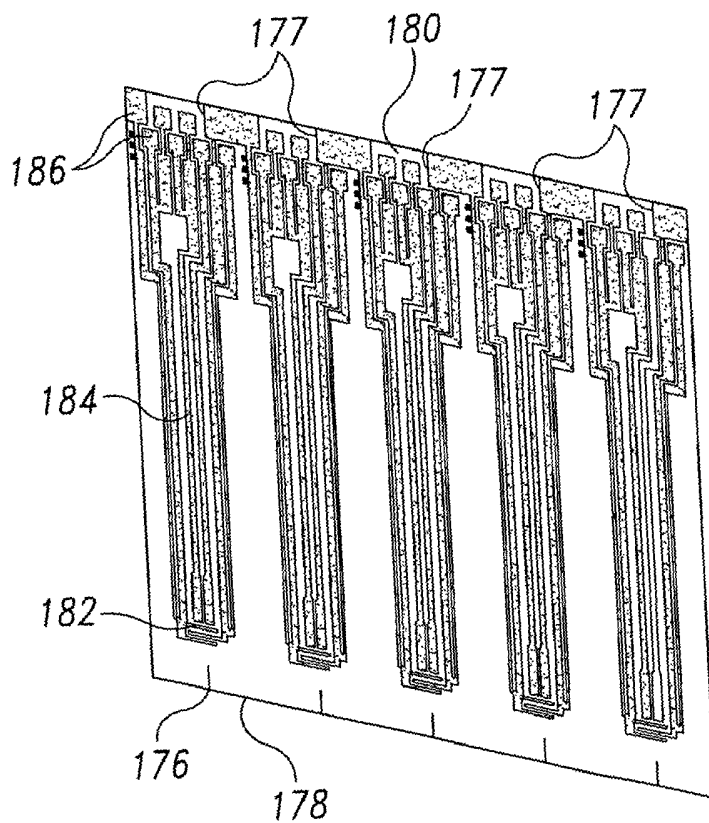
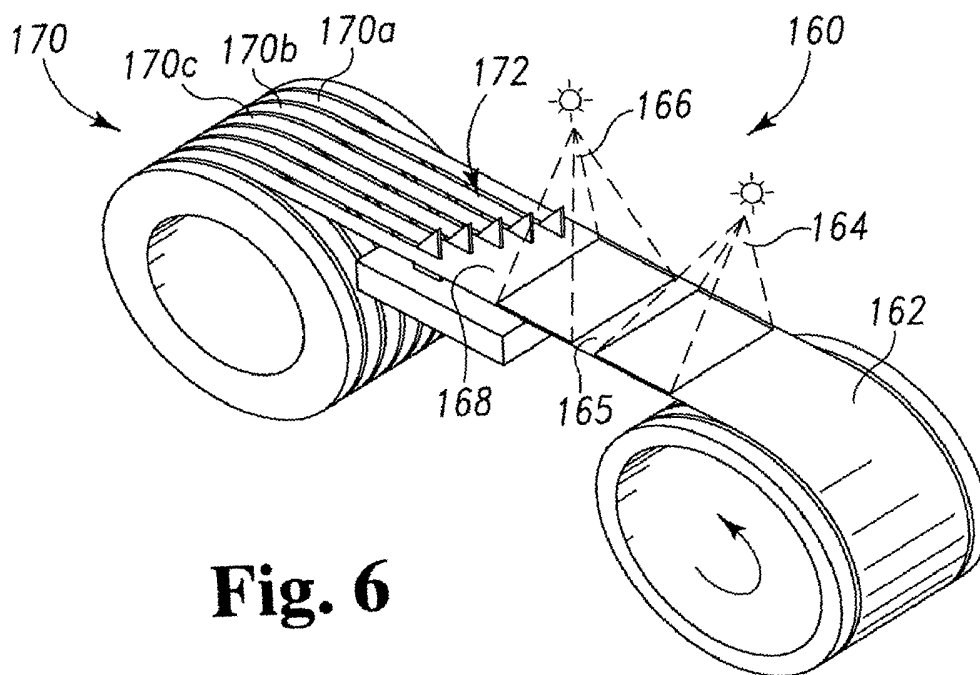

Fig. 5A



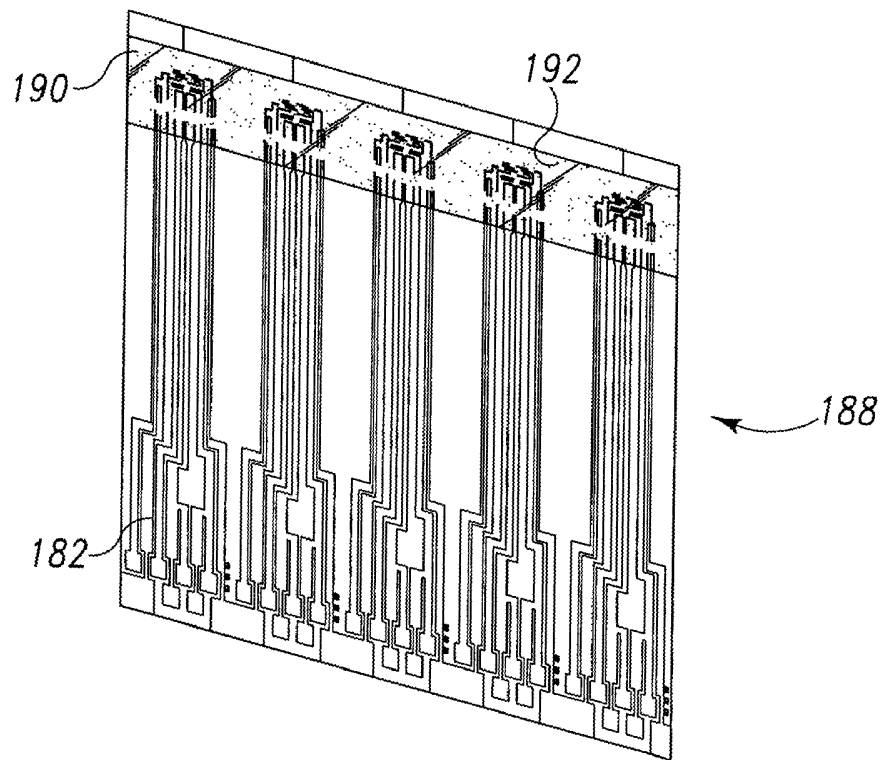

Fig. 8

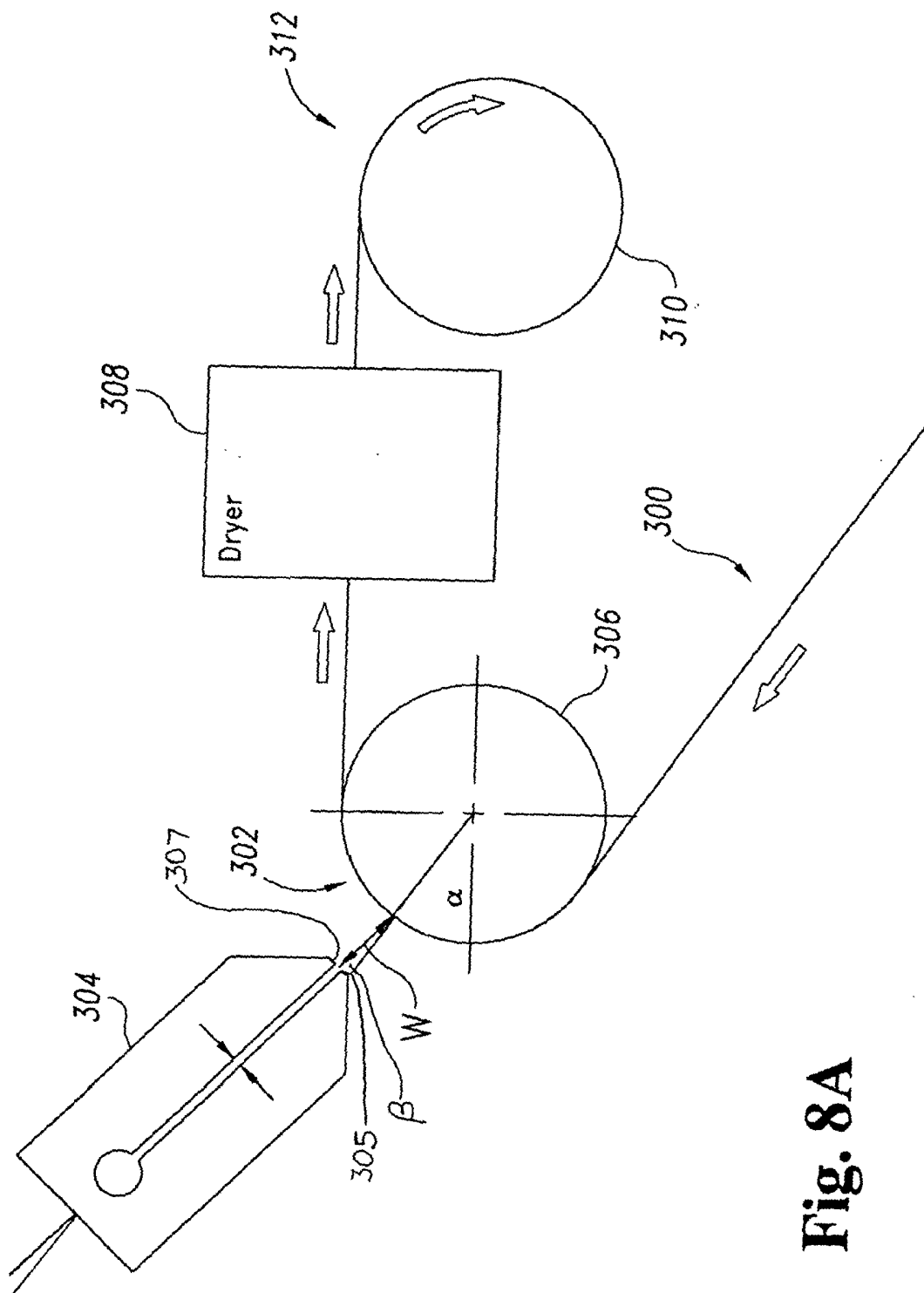

Fig. 8A

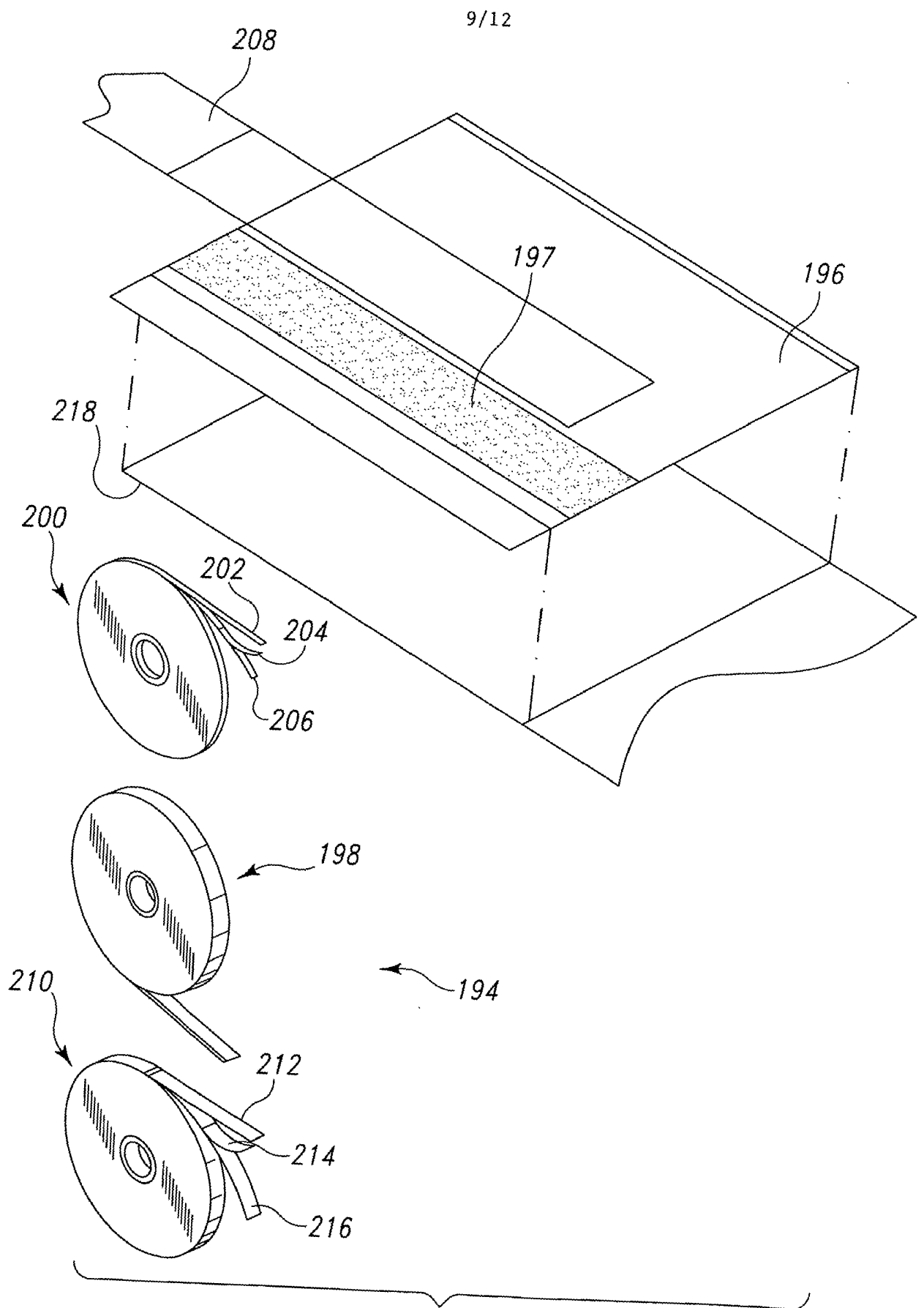

Fig. 9

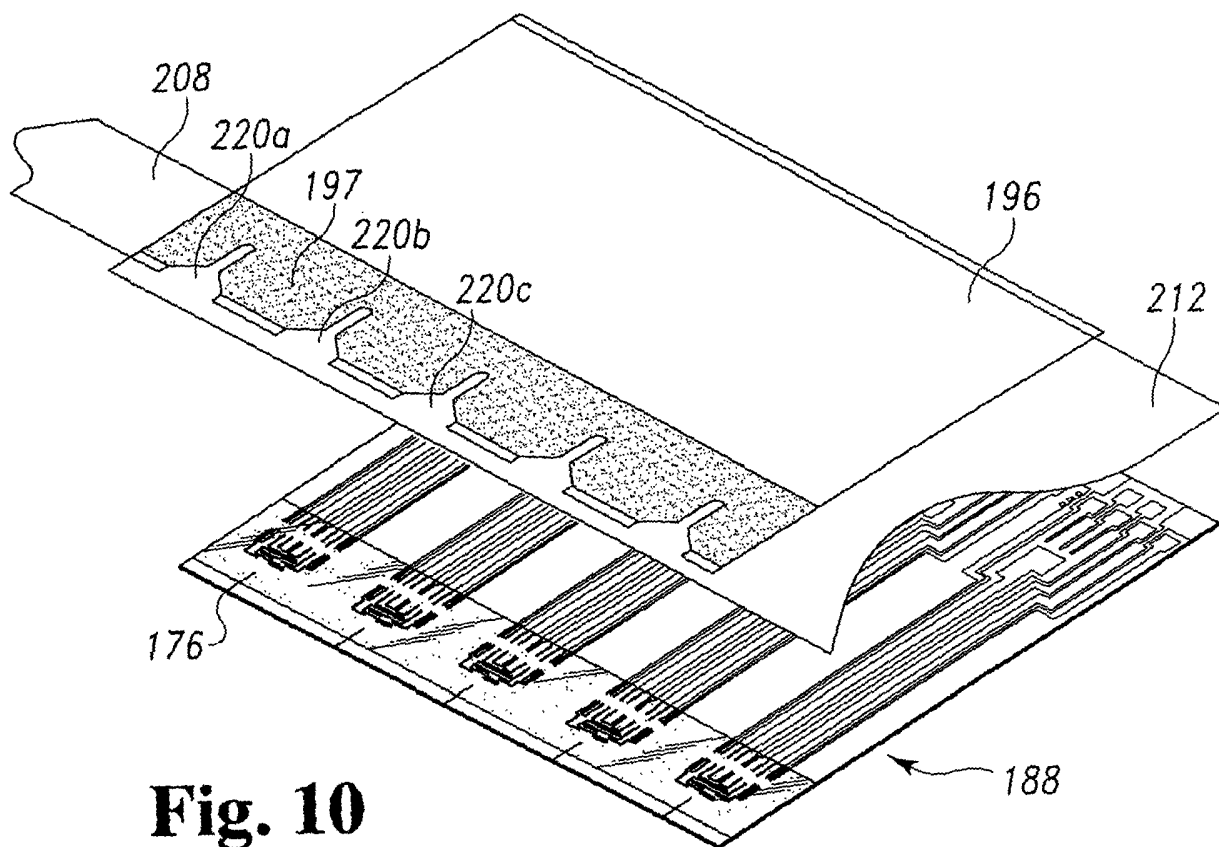

Fig. 10

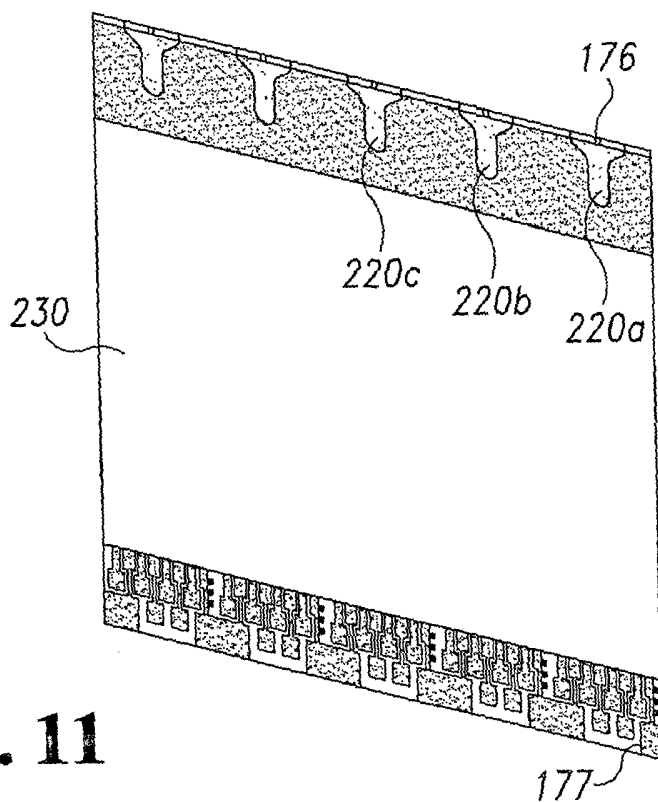

Fig. 11

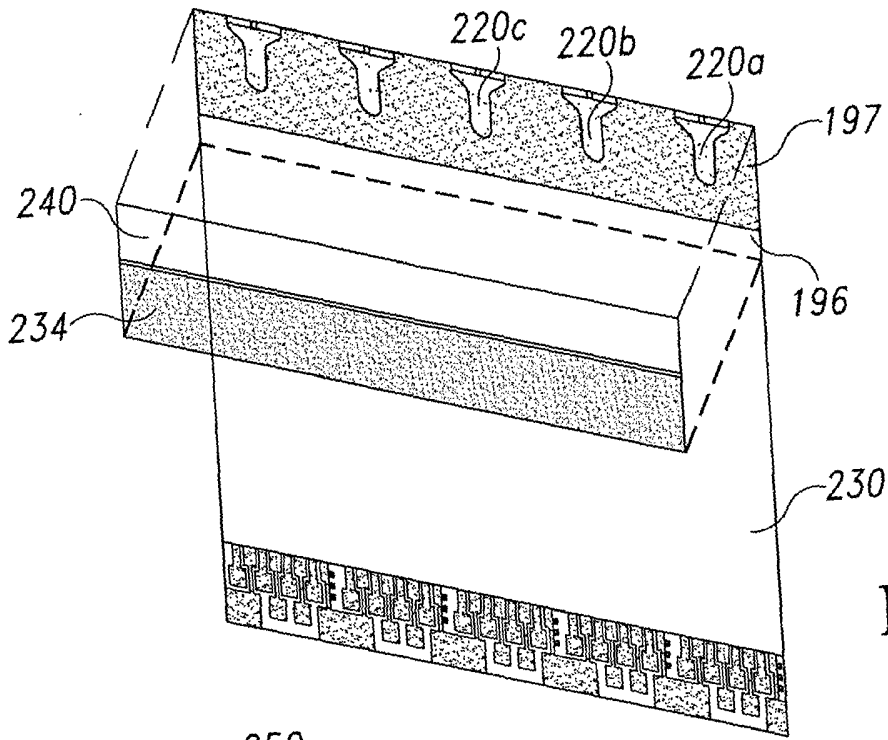

Fig. 12

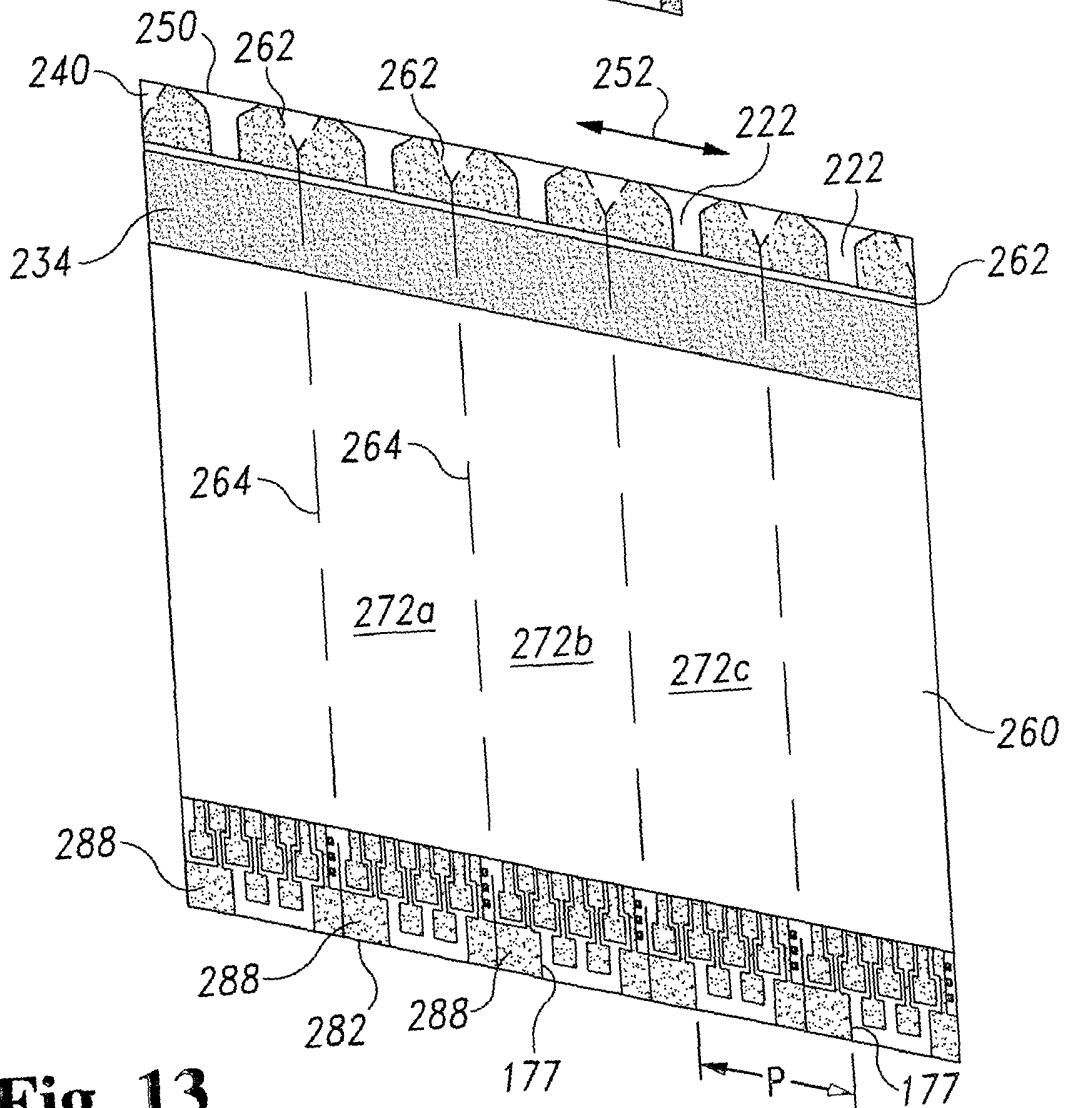

Fig. 13

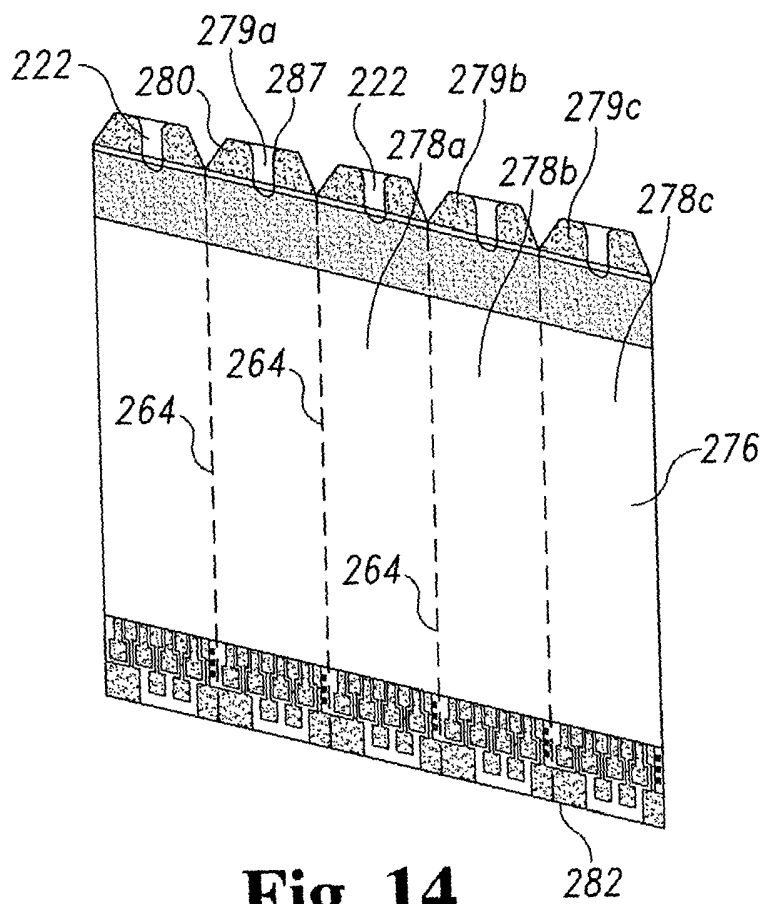
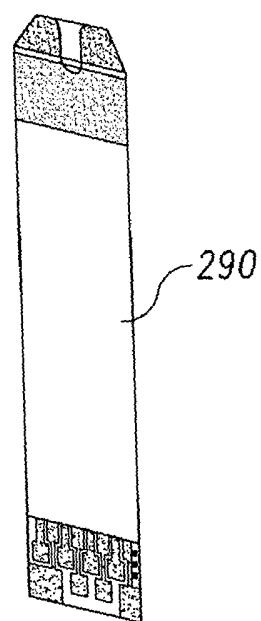

Fig. 14

Fig. 15



INTERNATIONAL SEARCH REPORT

International Application No
PCT/US2004/019687

A. CLASSIFICATION OF SUBJECT MATTER
IPC 7 G01N27/30 C12Q1/00

According to International Patent Classification (IPC) or to both national classification and IPC

B. FIELDS SEARCHED

Minimum documentation searched (classification system followed by classification symbols)
IPC 7 G01N C12Q

Documentation searched other than minimum documentation to the extent that such documents are included in the fields searched

Electronic data base consulted during the international search (name of data base and, where practical, search terms used)

EPO-Internal, WPI Data, PAJ

C. DOCUMENTS CONSIDERED TO BE RELEVANT

Category °	Citation of document, with indication, where appropriate, of the relevant passages	Relevant to claim No
	-/--	

Further documents are listed in the continuation of box C

Patent family members are listed in annex.

° Special categories of cited documents

- *A* document defining the general state of the art which is not considered to be of particular relevance
- *E* earlier document but published on or after the international filing date
- *L* document which may throw doubts on priority claim(s) or which is cited to establish the publication date of another citation or other special reason (as specified)
- *O* document referring to an oral disclosure, use, exhibition or other means
- *P* document published prior to the international filing date but later than the priority date claimed

- *T* later document published after the international filing date or priority date and not in conflict with the application but cited to understand the principle or theory underlying the invention
- *X* document of particular relevance, the claimed invention cannot be considered novel or cannot be considered to involve an inventive step when the document is taken alone
- *Y* document of particular relevance, the claimed invention cannot be considered to involve an inventive step when the document is combined with one or more other such documents, such combination being obvious to a person skilled in the art.
- *Z* document member of the same patent family

Date of the actual completion of the international search

23 November 2004

Date of mailing of the international search report

02/12/2004

Name and mailing address of the ISA
European Patent Office, P.B. 5818 Patentlaan 2
NL - 2280 HV Rijswijk
Tel (+31-70) 340-2040, Tx 31 651 epo nl,
Fax (+31-70) 340-3016

Authorized officer

Johnson, K

INTERNATIONAL SEARCH REPORT

International Application No

PCT/US2004/019687

C.(Continuation) DOCUMENTS CONSIDERED TO BE RELEVANT		
Category °	Citation of document, with indication, where appropriate, of the relevant passages	Relevant to claim No
X	EP 1 260 589 A (ROCHE DIAGNOSTICS) 27 November 2002 (2002-11-27)	1-5, 7-12, 26-30, 33,34, 36-38, 42-49, 54-58, 60-68, 74,76
Y		15-25, 39-41, 50-53, 69-73
A	paragraph '0009! - paragraph '0037!; figures	6,13,14, 31,32, 35,39, 40, 50-52, 59, 69-73,75
Y	----- WO 98/30904 A (MERCURY DIAGNOSTICS INC ; DOUGLAS JOEL S (US); GLEISNER JOHN M (US)) 16 July 1998 (1998-07-16)	23-25, 41,53
A	page 8, line 11 - page 13, line 17; figure 1	42
A	----- US 6 036 919 A (KNAPPE WOF GANG-REINHOLD ET AL) 14 March 2000 (2000-03-14) figure 2; example 1	25,41
A	----- US 2003/024811 A1 (DAVIES OLIVER WILLIAM HARDWICK ET AL) 6 February 2003 (2003-02-06)	42-46
Y	paragraph '0020! - paragraph '0042!; figures 1-3,8A-8C	15-22, 39,40, 50-52, 69-73
X	----- PATENT ABSTRACTS OF JAPAN vol. 2000, no. 03, 30 March 2000 (2000-03-30) & JP 11 337514 A (OMRON CORP), 10 December 1999 (1999-12-10)	26-30, 32-38, 57-68, 74-76
A	paragraph '0054! - paragraph '0070! paragraph '0091! - paragraph '0105!; figures 1,7,8	1-14,23, 24
	----- -/--	

INTERNATIONAL SEARCH REPORT

International Application No
PCT/US2004/019687

C.(Continuation) DOCUMENTS CONSIDERED TO BE RELEVANT		
Category °	Citation of document, with indication, where appropriate, of the relevant passages	Relevant to claim No.
P, X	EP 1 391 716 A (LIFESCAN INC) 25 February 2004 (2004-02-25) paragraph '0020! - paragraph '0029! paragraph '0040! - paragraph '0048!; figures 3-5 -----	57, 58, 65-74

INTERNATIONAL SEARCH REPORT

Information on patent family members

International Application No

PCT/US2004/019687

Patent document cited in search report		Publication date	Patent family member(s)	Publication date
EP 1260589	A	27-11-2002	US 2002192115 A1	19-12-2002
			CA 2387283 A1	25-11-2002
			EP 1260589 A2	27-11-2002
			JP 2003014687 A	15-01-2003
WO 9830904	A	16-07-1998	AU 5820798 A	03-08-1998
			CA 2277306 A1	16-07-1998
			DE 19880001 T0	18-03-1999
			EP 0977986 A1	09-02-2000
			GB 2323442 A ,B	23-09-1998
			JP 2001518179 T	09-10-2001
			US 5876957 A	02-03-1999
			WO 9830904 A1	16-07-1998
			US 6121011 A	19-09-2000
US 6036919	A	14-03-2000	DE 19629656 A1	29-01-1998
			AT 225937 T	15-10-2002
			AU 702224 B2	18-02-1999
			AU 2866197 A	05-02-1998
			CA 2210770 A1	23-01-1998
			CN 1176389 A ,B	18-03-1998
			CZ 9702275 A3	15-07-1998
			DE 59708414 D1	14-11-2002
			DK 821234 T3	10-02-2003
			EE 9700162 A	16-02-1998
			EP 0821234 A2	28-01-1998
			ES 2184013 T3	01-04-2003
			HK 1008566 A1	20-02-2004
			HR 970401 A1	30-04-1998
			HU 9701272 A2	28-08-1998
			IL 121353 A	31-08-2000
			JP 3394892 B2	07-04-2003
			JP 10078430 A	24-03-1998
			KR 220659 B1	15-09-1999
			NO 973381 A	26-01-1998
NZ 328376 A	23-12-1998			
PL 321252 A1	02-02-1998			
PT 821234 T	28-02-2003			
RU 2192641 C2	10-11-2002			
SK 99197 A3	11-01-1999			
TW 514727 B	21-12-2002			
ZA 9706465 A	22-01-1999			
US 2003024811	A1	06-02-2003	AU 4960101 A	08-10-2001
			CA 2403646 A1	04-10-2001
			CN 1439057 T	27-08-2003
			EP 1311702 A2	21-05-2003
			JP 2003529061 T	30-09-2003
			WO 0173109 A2	04-10-2001
US 2004026243 A1	12-02-2004			
JP 11337514	A	10-12-1999	NONE	
EP 1391716	A	25-02-2004	US 2003150745 A1	14-08-2003
			CA 2437998 A1	23-02-2004
			EP 1391716 A2	25-02-2004
			JP 2004132966 A	30-04-2004