



(86) Date de dépôt PCT/PCT Filing Date: 2002/12/17  
 (87) Date publication PCT/PCT Publication Date: 2003/07/03  
 (85) Entrée phase nationale/National Entry: 2004/06/11  
 (86) N° demande PCT/PCT Application No.: US 2002/040058  
 (87) N° publication PCT/PCT Publication No.: 2003/054439  
 (30) Priorité/Priority: 2001/12/20 (10/028,126) US

(51) Cl.Int.<sup>7</sup>/Int.Cl.<sup>7</sup> G06F 15/16  
 (71) Demandeur/Applicant:  
 QUESTRA CORPORATION, US  
 (72) Inventeurs/Inventors:  
 BALLER, ERIC HENRY, US;  
 CANOSA, JOHN THOMAS, US;  
 COOK, JOHN MAITLAND, III, US;  
 HART, DAVID PATRICK, US;  
 KUNTZ, CHRISTOPHER JAMES, US;  
 TAYLOR, JOHN LOUIS, US;  
 PSARROS, DIMITRIOS, US;  
 RAMAN, RAJEEV, US;  
 CHIARELLA, THOMAS, US

(74) Agent: NELLIGAN O'BRIEN PAYNE LLP

(54) Titre : PROCEDE ET APPAREIL DE GESTION DE BIENS INTELLIGENTS DANS UN ENVIRONNEMENT REPARTI  
 (54) Title: METHOD AND APPARATUS FOR MANAGING INTELLIGENT ASSETS IN A DISTRIBUTED ENVIRONMENT

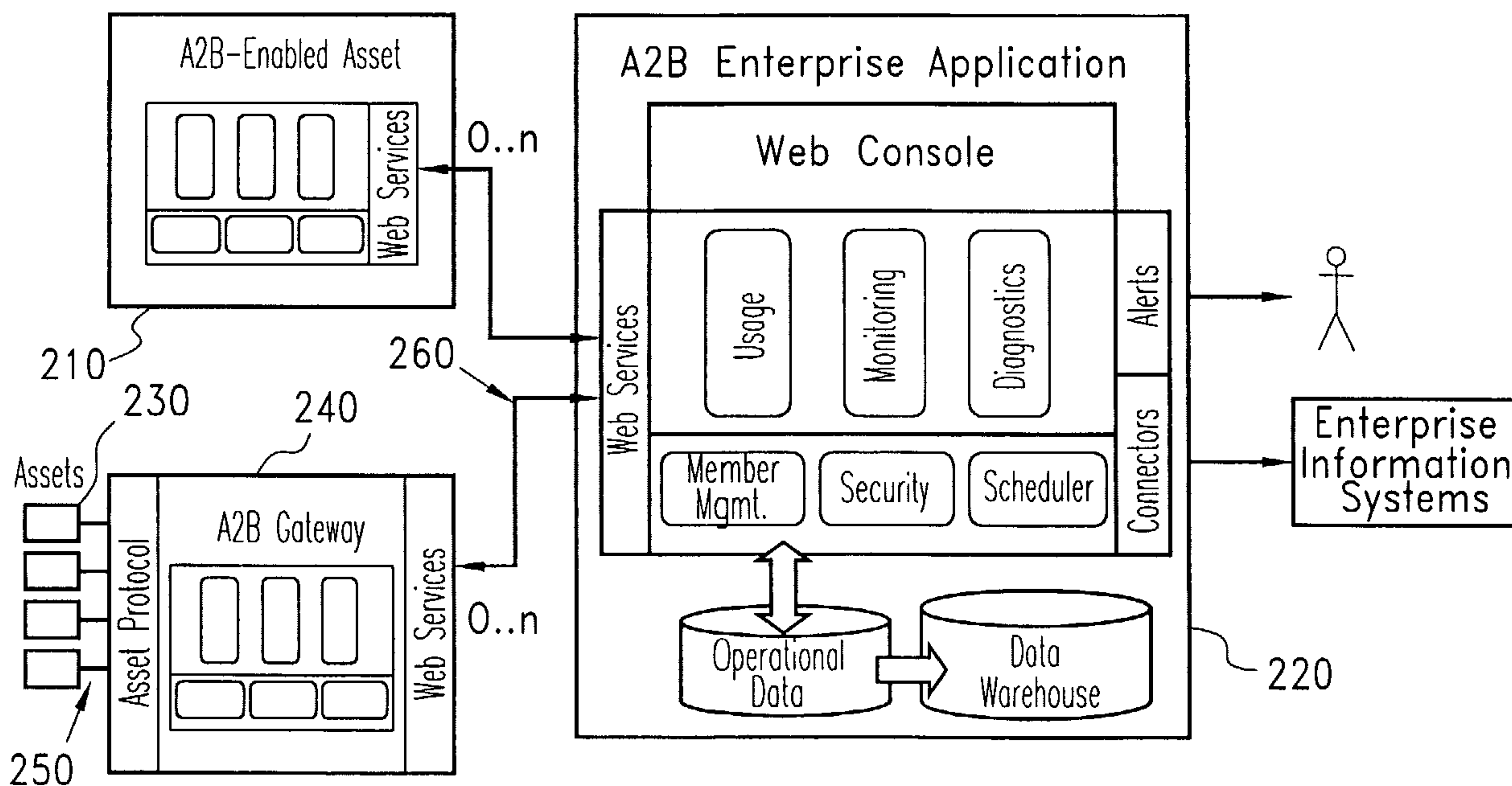

(57) **Abrégé/Abstract:**

A method is described which provides for managing intelligent equipment that is deployed remotely. The capabilities of managing such distributed assets include both infrastructural capabilities to establish and maintain connection through a variety of wired and wireless mechanisms and application modules that provide distributed asset management capabilities. The system allows for enterprise application (220) to interact with and enabled asset (210). Assets can connect to the enterprise by passing through a gateway (240).

(12) INTERNATIONAL APPLICATION PUBLISHED UNDER THE PATENT COOPERATION TREATY (PCT)

(19) World Intellectual Property Organization  
International Bureau



(43) International Publication Date  
3 July 2003 (03.07.2003)

PCT

(10) International Publication Number  
WO 03/054439 A3

(51) International Patent Classification<sup>7</sup>: G06F 15/16

(21) International Application Number: PCT/US02/40058

(22) International Filing Date:  
17 December 2002 (17.12.2002)

(25) Filing Language: English

(26) Publication Language: English

(30) Priority Data:  
10/028,126 20 December 2001 (20.12.2001) US

(71) Applicant: QUESTRA CORPORATION [US/US]; 350 Linden Oaks, Rochester, NY 14625 (US).

(72) Inventors: BALLER, Eric, Henry; 544 Forest Lawn Road, Webster, NY 14580 (US). CANOSA, John, Thomas; 31 High Point Drive, Spencerport, NY 14559 (US). COOK, John, Maitland, III; 1007 Silvercrest Drive, Webster, NY 14580 (US). HART, David, Patrick; 26 Lincolnshire Road, Webster, NY 14580 (US). KUNTZ, Christofer, James; 169 Millford Crossing, Penfield, NY 14526 (US). TAYLOR, John, Louis; 42 St James Drive, Webster, NY 14580 (US). PSARROS, Dimitrios;

781 Elmwood Terrace, Rochester, NY 14620 (US). RAMAN, Rajeev; 20118 Forest Avenue, Cupertino, CA 95014 (US). CHIARELLA, Thomas; 398 Upland Road, Redwood City, CA 94062 (US).

(74) Agents: SALAI, Stephen, B. et al.; Harter, Secrest & Emery LLP, 1600 Bausch & Lomb Place, Rochester, NY 14604-2711 (US).

(81) Designated States (national): AE, AG, AL, AM, AT, AU, AZ, BA, BB, BG, BR, BY, BZ, CA, CH, CN, CO, CR, CU, CZ, DE, DK, DM, DZ, EC, EE, ES, FI, GB, GD, GE, GH, GM, HR, HU, ID, IL, IN, IS, JP, KE, KG, KP, KR, KZ, LC, LK, LR, LS, LT, LU, LV, MA, MD, MG, MK, MN, MW, MX, MZ, NO, NZ, OM, PH, PL, PT, RO, RU, SD, SE, SG, SK, SL, TJ, TM, TN, TR, TT, TZ, UA, UG, UZ, VN, YU, ZA, ZM, ZW.

(84) Designated States (regional): ARIPO patent (GH, GM, KE, LS, MW, MZ, SD, SL, SZ, TZ, UG, ZM, ZW), Eurasian patent (AM, AZ, BY, KG, KZ, MD, RU, TJ, TM), European patent (AT, BE, BG, CH, CY, CZ, DE, DK, EE, ES, FI, FR, GB, GR, IE, IT, LU, MC, NL, PT, SE, SI, SK, TR), OAPI patent (BF, BJ, CF, CG, CI, CM, GA, GN, GQ, GW, ML, MR, NE, SN, TD, TG).

[Continued on next page]

(54) Title: METHOD AND APPARATUS FOR MANAGING INTELLIGENT ASSETS IN A DISTRIBUTED ENVIRONMENT

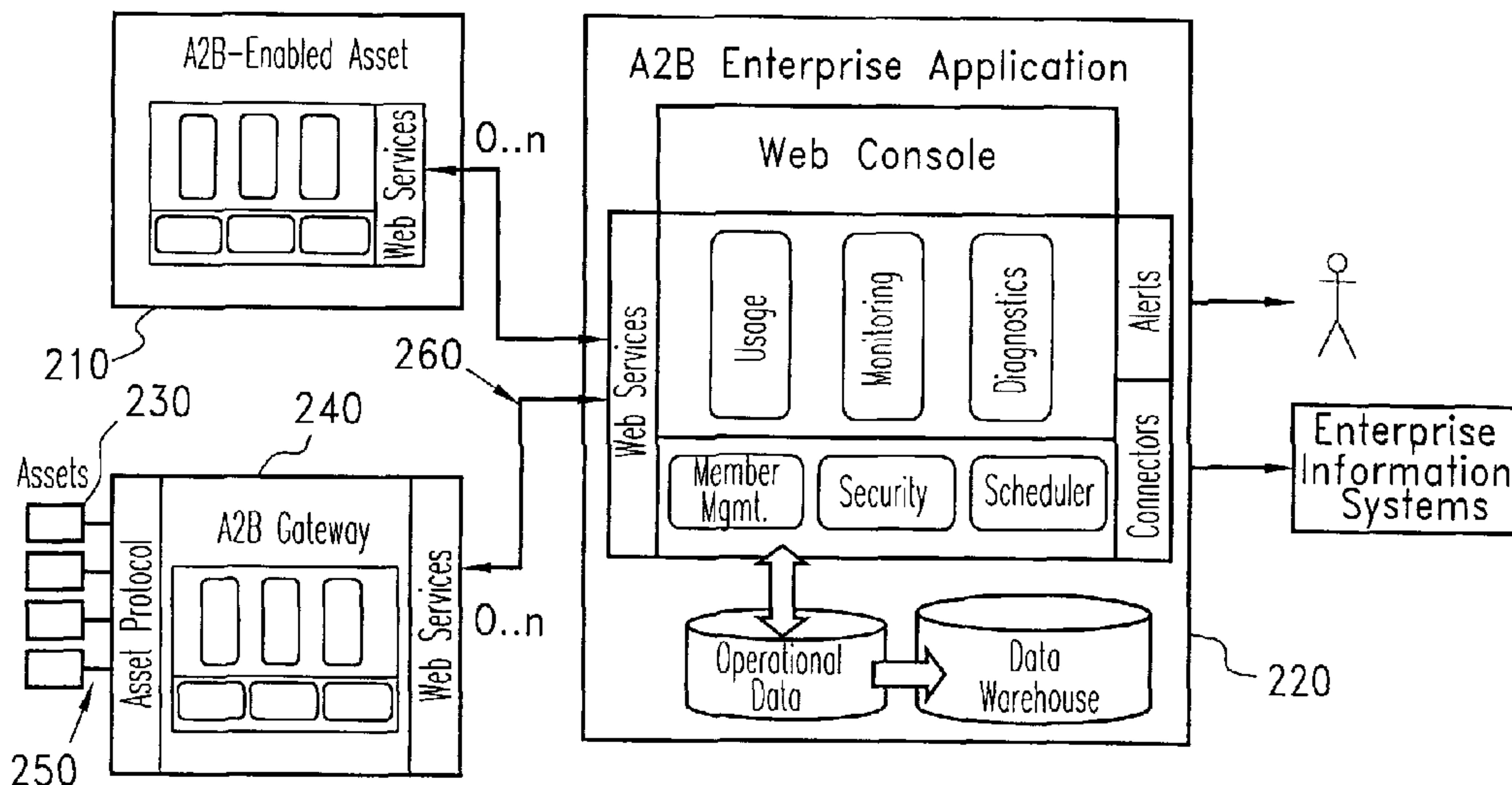

(57) Abstract: A method is described which provides for managing intelligent equipment that is deployed remotely. The capabilities of managing such distributed assets include both infrastructural capabilities to establish and maintain connection through a variety of wired and wireless mechanisms and application modules that provide distributed asset management capabilities. The system allows for enterprise application (220) to interact with and enabled asset (210). Assets can connect to the enterprise by passing through a gateway (240).

WO 03/054439 A3

**WO 03/054439 A3**



**Declarations under Rule 4.17:**

- *as to applicant's entitlement to apply for and be granted a patent (Rule 4.17(ii)) for all designations*
- *as to the applicant's entitlement to claim the priority of the earlier application (Rule 4.17(iii)) for all designations*

**Published:**

- *with international search report*
- *before the expiration of the time limit for amending the claims and to be republished in the event of receipt of amendments*

**(88) Date of publication of the international search report:**  
24 December 2003

*For two-letter codes and other abbreviations, refer to the "Guidance Notes on Codes and Abbreviations" appearing at the beginning of each regular issue of the PCT Gazette.*



a second input signal indicative of utilization associated with each user at each copying machine. These data signals are stored and later transmitted to a central managing unit. The terminal receives a signal from the copying machine to which it is connected representing the number of copies made by the copying machine and which user made  
5 the copies. This information is transmitted to a central unit at a later date. One of the disadvantages of this system is that it does not monitor operating malfunctions of the copier or notify a service center when preventive maintenance is required.

Another monitoring system is known in the art from U.S. Pat. No. 5,077,582. This counter counts the number of papers processed by the copier producing a count  
10 signal. A monitoring system computer receives the count signal and increments a count value over a predetermined period. An interface circuit monitors the operation of the copier by monitoring the internal diagnostic signals of the copier as displayed on a photocopier display device associated with each copier. The interface circuit signals a central station when a malfunction of the copier has occurred, indicating the nature of  
15 the problem by translating the diagnostic signal and transmitting a translated diagnostic signal. A modem receives the accumulative count and diagnostic signals from the monitoring system computer and transmits each signal to the appropriate party at the central station.

The disadvantage of this prior art is its reliance on the mechanical counter  
20 interface and capturing the signals intended for the photocopier display device. In modern digital copy / print / fax / scan devices, commonly referred to as multi-function devices, these mechanical and display device interfaces are either non-existent or grossly inadequate to accurately capture performance and usage information from the device. The present invention overcomes this disadvantage by providing a direct digital  
25 interface through software, able to access device status, fault, usage, and log information that is not available mechanically.

As depicted in Fig. 1, the A2B software includes a Device Framework component [110 and 120] that can be connected through a digital interface to the device [Adjacent Deployment – 130] or installed directly on the processor within the device to  
30 be monitored [Embedded Deployment – 140] . A centralized Enterprise System [150]

coordinates activities and provides user access to asset management applications. Communications between components occur through a variety of media, including wired Internet, dial-up telecommunications, and wireless.

Intelligent devices have grown in their own ability to self-diagnose and alert  
5 local users to fault situations through a control panel. In most cases, though, this information is only available to users or repair technicians physically at the location of the device. In U.S. Pat. No. 6,317,848, a system is described for recording data within the asset. Upon reaching a trigger point, an email is automatically sent to a number of  
10 email addresses containing a specially formatted data record of data that was previously recorded. The shortcomings of this approach include the limited flexibility in data retrieved, scheduling of transmissions, and reliance on email. The present invention allows for dynamic changes to the information retrieved, allowing greater or lesser visibility in to the functioning of the asset – saving data transmission costs when not necessary and providing additional detail when required. The current invention allows  
15 this to be configured from a centralized enterprise system and then directed to the specific asset without human interaction with that specific asset. In addition, the prior art established these parameters on the asset, requiring a physical presence at the asset to make changes. The current invention again allows a centralized enterprise system to control and update these parameters at any time.

20 For some recent computer-based equipment, remote computer control software has been used to allow the console of the equipment to be remotely located. This has progressed through the prior art from rudimentary text-based dialup terminal emulation to more sophisticated remote control systems that include the capability for graphics. *Carbon Copy 32* from Compaq and *LapLink* from Traveling Software utilize "hooks" in  
25 the display subsystem of the remote computer to capture drawing requests and enabling a graphical user interface of the remote computer to be displayed at a user's local computer. *PCAnywhere* produced by Symantec of Cupertino, Calif. is an additional remote control program requiring server software on the remote computer in order to transfer graphics between computers of the same operating system. U.S. Pat. No.  
30 5,732,212 discloses a system in which the video, keyboard and mouse ports of a remote

computer are connected to a host unit and the video raster signal is converted to digital form. U.S. Pat. No. 6,304,895 discloses a system to provide control of a remote computer independent of the operating system by capturing the signals sent to and from peripheral devices such as the keyboard and display. In all of these previous cases, the  
5 intent of the invention was to allow a *user* to have access to a remote *PC*. The present invention does not require the presence of a user in order for monitoring information to be collected, transmitted, analyzed, and acted upon. It also does not require the remote access to be a personal computing device but instead has been designed to operate on a wide variety of specific operating systems, including Windows, Unix, and embedded  
10 real-time operating systems.

For computer to computer interaction that does not require a user to be present, the prior art includes the concept of a Remote Procedure Call (RPC) mechanism to communicate the invocation of server procedures. This approach worked well within the bounds of a business because the network communications were all trusted. To  
15 communicate with other businesses, or to communicate in any way across the public Internet, required a special security setup to create “holes” in the firewall protecting information systems. Most firewalls do permit HTTP traffic, the protocol used by browsers to retrieve web pages. This has given rise to a new model of RPC, known as Web Services. Based on text messages formatted with eXtensible Markup Language  
20 (XML), a new standard has emerged to package requests as messages. These standards, including WSDL (Web Service Description Language), SOAP (Simple Object Access Protocol), and XML, are gaining popularity for the interconnection of business systems – B2B (Business to Business) commerce – but have not been applied to the interconnection of individual intelligent assets.

25

#### DISCLOSURE OF INVENTION

This invention provides a means of establishing a direct computer-based connection to remote equipment through Internet standard protocols. It provides both the underlying infrastructure for this interaction and the set of capabilities required to  
30 remotely monitor, control, diagnose, and manage remote equipment.

By taking advantage of the processing power within the remote equipment itself or an accompanying module, as minimal as it may be, we provide a direct link to the intelligence within the equipment. Access to equipment status, usage counts, diagnostic utilities, and other features are provided programmatically, as a system-to-system  
5 connection, unlike previous solutions that required a user to manually initiate action. This provides significantly more capability than simply allowing a local console user to be at a remote location.

Additional flexibility is provided through a mechanism for scheduling interactions between the asset and the centralized server. In cases where  
10 communications is impeded by wireless links or firewalls, an asynchronous messaging and polling mechanism is provided.

#### BRIEF DESCRIPTION OF DRAWINGS

Fig. 1 is a block diagram showing the high-level conceptual architecture of a  
15 system in accordance with the invention.

Fig. 2 is a block diagram showing the logical system architecture, including application modules.

Fig. 3 is a diagrammatic illustration of an embodiment of the invention with a gateway.

20 Fig. 4 is a detailed representation of the structure of a SOAP Encoded a2bML message.

Figs. 5a-c are listings showing an a2bML message in various forms.

Fig. 6 is a diagrammatic view of an embodiment of the invention showing the typical action of a firewall to prohibit direct external access to internal resources.

25 Fig. 7 is a diagram that illustrates the basic steps of a polling sequence to communicate Web Service requests through one-way filters such as a firewall.

Fig. 8 is a diagrammatic view of an embodiment of the invention that includes a Proxy server.

Fig. 9 is a diagrammatic view of a Wireless embodiment of the invention.

Fig. 10 is a block diagram that illustrates the tiers of an application server in accordance with the invention.

Fig. 11 is a block diagram view in to the software components within a  
5 centralized server.

#### BEST MODE(S) FOR CARRYING OUT THE INVENTION

The present invention solves a Distributed Asset Management (DAM) problem. Inexpensive and somewhat ubiquitous communications capabilities have created the  
10 environment whereby nearly any smart device, machine or piece of equipment, no matter how small or remote, can be hooked up and monitored. Today, assets as diverse as vending machines, leased tractors and oil-well pumps can be electronically monitored in a simple and cost-effective manner.

This invention provides both an infrastructure through which any device can  
15 interact with any enterprise system and it provides the *solution* for DAM.

The Distributed Asset Management space is, by its nature, heavily distributed. The enterprise and the assets being managed share in the responsibility of providing the required business logic. This invention not only provides the enterprise software to enable communication with a wide range of assets, but also provides robust support for  
20 the embedded systems residing in assets.

#### System Architecture

A fundamental aspect of A2B is the mechanism(s) used to communicate between assets and the A2B Enterprise Application. Key to this interaction is the ability to perform distributed communication across the Internet. The system-level architecture  
25 focuses on addressing the interaction between assets and the enterprise application.

Fig. 2 illustrates that an A2B-Enabled Asset [210] interacts with the A2B Enterprise Application 220. Web Services (based on SOAP/XML, URL encoding, WSDL, etc) provide for the required capability of doing distributed computing between

these two components. Many assets can be natively enabled, via Qestra's embedded platform, to communicate with the enterprise using A2B Web Services.

Alternately, assets [230] can connect to the enterprise by passing through an A2B Gateway 240. The A2B Gateway masquerades for a set of assets [230], translates  
5 addresses, and provides any necessary protocol conversions needed to "speak the native language of the enterprise" (i.e., Web Services).

The A2B Gateway 240 can be implemented on an embedded system, connected directly to the assets through asset protocols such as BACnet (Building Automation and Control network), Modbus, proprietary protocols, etc., or connected indirectly to the  
10 asset by connecting sensors, monitoring contact points, etc.

A2B Gateway software can be implemented on enterprise class computing systems when the need for horizontal scalability is required. Such gateways can be deployed inside of a corporation's firewall. For example, if the assets [230] use Simple Network Management Protocol (SNMP) on the internal network [250], the Gateway  
15 240 can also provide an additional layer of security (e.g., SSL) for transmission across a less secure network [260] such as the Internet.

Alternatively, Fig. 3 illustrates that the gateway software [310] can also be deployed to deal with asset communication and control networks that are either non-TCP/IP or using messaging other than a2bML such as a wireless provider [330]. This  
20 allows the centralized server [320] to remain insulated from the specifics of the protocol used on the remote network [340]. The Gateway provides any necessary address translation and protocol translation, similar to the capability to the gateway cited in Fig. 2, but it is located on the enterprise side of the wireless connection – typically located at the wireless NOC or the enterprise server site, adjacent to the centralized  
25 server [320]. Note that the actual software deployed to provide the gateway capability may be deployed on a separate machine, as shown in the diagram, or as a module on the centralized server.

Fields in the A2B headers are used for handling scenarios where intermediaries are involved in the path of a message from the originator to the final destination.

The following sections provide greater detail on the communication between assets and the enterprise, including discussion of Web Services, Gateways, and Application Modules.

### A2bML

5

A *Web Service* is a software program that provides a business service and is accessible over the Internet. An architecture that is based on Web Services is the evolution from a system of distributed object-oriented components to a network of services, providing a loosely couple infrastructure that enable cross-enterprise  
10 integration.

The *a2bML* defines the message that the enterprise server software will operate on. The a2bML is an XML based meta-language the enables cross-platform data interchange using a standard method for encoding and formatting information related to A2B services.

15

The a2bML consists of both message header information used to process messages and a message body used to communicate the specifics of the message. The header typically includes information for security and routing of requests. Examples of objects and their methods included in the body of a message are: Registration (register device, register user), Security (logon, logoff), Remote Monitoring (submit current  
20 value, update schedule), Usage Metering (submit current reading, initialized meter), and so on. A2bML is represented by XML Schema and WSDL specifications. Each a2bML message includes a namespace URI specifying the version of the a2bML language.

### SOAP Encoding

A2B messaging leverages SOAP as an open and simple solution for invoking  
25 A2B services across the Internet. A standard A2B message is shown in Fig. 4 and consists of:

- (a) Outer Communication Protocol Envelope [410] (HTTP, MIME, SMTP, etc.)

(b) Inner “communication protocol independent” SOAP Message Envelope 420 that serves as a container for the two main parts of the SOAP Message.

(c) SOAP Header container [430] used to envelop one a2bML Header Document containing 0, 1, or several header elements 440.

5 (d) SOAP Body container [450] used to envelop the a2bML document containing the message name and data. Specifically, the body contains 0, 1, or several A2B method names and associated parameters [460].

Note that by de-coupling the header information from the a2bML message body, modifications to the header will not impose on the A2B service developer. The body  
10 contains only the data/information for that specific A2B request message.

Fig. 5a shows a sample of a SOAP-encoded message that would be transmitted over a standard communications protocol. The protocol envelope is not visible in this text, but the following elements described for Fig. 4 are apparent here:

(a) Inner “communication protocol independent” SOAP Message Envelope  
15 [520].

(b) SOAP Header container [530]

(c) One a2bML Header Document [540].

(d) SOAP Body container [550]

(e) A2B method names and associated parameters [560].

## 20 URL Encoding

As an efficient alternative to SOAP encoding, this invention includes a means to encode the invocation of Web Services through HTTP’s POST method. This overcomes situations in which SOAP is impractical, such as:

(a) A device-side SOAP encoder is not technically viable due to the device  
25 platform’s lack of resources

(b) The message size of the SOAP message is prohibitive due to networking costs and limitations (SMS networks, for instance)

(c) A political barrier to the use of SOAP technology cannot be overcome

Complex, structured data can be sent via URL encoding by using a dot notation on the URL attribute names. Fig. 5b shows the URL encoded data of Fig. 5a. This mapping is accomplished through a combination of:

(a) standard hex encoding of data, such as converting <space> to <%20>

(b) automatically rooting the body contents at the operation named in the header

(c) indicating tag parameters with '@'

(d) indicating tag nesting with '.'

#### Compact URL

As a further means of economizing the message size, this invention covers a further encoding of the message data. This includes compression techniques and encoding techniques, such as abbreviating each tag with the minimal initial characters required to uniquely identify it. Fig. 5c provides an example of such an encoding scheme, though other algorithms could be applied.

#### Multi-Part Mime (Attachments)

An extension applicable to both SOAP and URL encoding is the use of multipart MIME (a main message with attachments). The attachments (when using MIME as part of an HTTP request) can include a binary encoded message.

#### Security

Many parties can access data transfer over the Internet, and sensitive data must be protected. The A2B request message header supports credentials for authentication and authorization, and includes an authentication token element obtained when a session is established. This token provides a means to authorize a particular client's invocation of the requested service.

SSL, digital signatures, and private key encryption are alternative implementations of security that can be applied to the message.

#### Firewalls, Dial-up Connections, and non-Public IP Addresses

While many DAM services are initiated by the asset, there are also many cases  
5 where the enterprise is the initiator and the asset must provide a response. This invention accomplishes that by allowing the device to act as a server, accessible from the Enterprise Application via a Web Service proxy.

This section outlines the strategies for supporting assets that need to receive unsolicited communications (typically from the centralized server). Among the  
10 challenges are:

(a) Firewalls – Fig. 6 illustrates the actions of most corporate firewalls [610] to allow client connections from elements inside the firewall [620] (think of your web browser), but to deny external connections to an entity inside the firewall by an entity on the outside [630]. Due to security considerations it is unlikely that a corporation will  
15 allow a “hole” in the firewall to be opened to allow connections to devices that are inside the corporate firewall. Therefore, this invention utilizes whichever port is open, typically port 80 for web traffic. Corporate proxy servers create similar issues.

(b) Dial-up Connections - Dial-up connections from a device elicit a similar problem as described above regarding firewalls. Typically, the only way to  
20 communicate with the device using dial-up is when the device initiates a connection with the server (regardless of standard firewall configurations).

(c) Non-public IP Addresses - Many assets are deployed with non-Public IP addresses (typically via a Network Address Translation (NAT) router, and in conjunction with a firewall). NAT routers are often not configured to create links from  
25 the Internet to any computer on the LAN. All assets behind such a router are hidden and inaccessible (i.e., not routable).

### Polling Servers for Web Services

A polling server gives an Internet client the ability to process unsolicited requests. In a polling server scenario, the client (usually the asset in an A2B system) periodically polls the server for any messages that are queued for the asset. This  
5 alleviates the problem presented by an unreachable IP addresses, but leads to a lack of responsiveness on the part of the asset as well as additional network traffic. Fig. 7 shows a polling server in action between an asset behind a firewall [710] and a centralized server [720].

This invention includes the application of polling servers to Web Services. Two  
10 separate messages are required to accomplish this through HTTP, which is an inherently request/response protocol. The first message is the request, which must be queued by the server for later deliver to the asset (we will assume the asset is unreachable through a firewall for this discussion, but that is only for purposes of the example). When the asset polls for messages, the first message is sent as the polling reply. Once the asset has  
15 completed the request and is ready to respond, such as with the current meter reading, the asset formats a second message to be sent to the server. Therefore, the response to this request for information from the asset is returned asynchronously and must be matched to the first message. This invention includes a tracking mechanism to log outgoing requests, reconcile incoming messages, and report timeout situations. This is  
20 preferably embodied in a database within the enterprise software, but could be tracked with other means.

Note that the amount of time between the message being queued for delivery to the device and the device processing the message is dependent on the polling interval on the device, leading to a degree of latency.

25 A slight improvement over the above sequence is for the asset to request a queued message rather than ask if any messages are available (of course, lack of a return message indicates that no messages are queued for the asset).

If the asset does receive a message, it should continue requesting messages until the server-side queue is exhausted. Note that a request for messages may return all messages that are queued.

5 An extension of this approach is to utilize a “keep-alive” connection to maintain an active communications path between asset and enterprise. This creates a channel through which real-time interaction can occur, such as Remote Diagnostics, from outside the corporate firewall.

### Adaptive Polling

10 An optimization to the polling server adds the ability to speed up the polling interval due to situational conditions. Consider the following use case relating to remote diagnostics:

- (a) Asset submits problem report
- (b) Technician is notified of the problem
- (c) Technician contacts the asset and performs remote diagnostics (either by  
15 querying asset properties, such as temperature and airflow, or by instructing the asset to execute internal diagnostics routines).

For example, an asset may be setup with a polling interval of once per day. If a problem is reported in the middle of the day and the technician desires to run a diagnostic test, the diagnostic command would wait in the polling queue until the end of  
20 the day when the asset polls again. Instead, this invention adapts the polling interval based on the situation. In this example, the fault notification causes the polling interval to shorten, perhaps to once per minute for 60 minutes. This allows the technician to have near real-time response to diagnostic requests for the expected duration of the diagnostic session.

25 The polling schedule change can be statically defined in the schedule for the asset (e.g. once per day; once per minute for 60 minutes upon fault) or dynamically changed based on the enterprise response (e.g. the fault message generates a reply from the enterprise server which contains an updated polling schedule such as once per

minute for 20 minutes). Note that a possible scenario is that the polling server is inactive until a situation requires polling (a trade-off for operational costs).

### Integrated Polling

5 What we call “integrated polling” is the ability for *any* communication from the asset to return information about queued data available for the asset. That is, every interaction with the enterprise is inherently a polling request. This represents an efficiency over the standard polling server in that communications from the asset that fall inside of a polling interval are sometimes more immediately available to the asset.

10 Note that the integrated polling server can be used either in conjunction with or in lieu of the standard polling server. A device that already has regularly scheduled communications with the server (e.g., heartbeats) can piggyback polling server capability. This makes it possible, for example, for a registration request from an asset to cause an update to the asset schedule – that is, an asset-initiated interaction can still cause an enterprise-initiated request to be processed.

### 15 Inquiry or Poll

The delivery of the queued message from the server to the asset may occur in a two-step process. The polling inquiry (an explicit poll or an integrated polling message) may cause the server to indicate in the response that a message is queued for that asset. This may be implemented as a flag in the response header or in other ways, to indicate 20 that a request for a pending message should be initiated by the asset. A further optimization on this solution is for the actual request that is queued for the asset to be returned as part of the asset-initiated communication.

### Internet Proxies

25 An alternative to the polling server in the case of firewalls (although not applicable for dial-up connections and non-public IP addresses) is the use of a proxy deployed at the corporation housing the asset(s). This is depicted as the “Gateway” in Fig. 2. Fig. 8 provides a more focused view of the proxy [810] that manages all communications with assets behind the firewall [820, 821, 822]. This single point of

contact allows communications to be closely monitored, and provides for additional on-site management of deployed assets.

The instance where the proxy is most desirable is in the case of a retrofit scenario, interfacing with an SNMP system for instance, where multiple devices are accessible on a LAN or with factory automation assets available over a serial connection. The proxy can also provide filtering and additional security, such as not forwarding patient-identifiable information that flows among medical devices on a Laboratory Information Management System.

Supporting SSL on the gateway is an attractive strategy in the proxy scenario given security concerns and the horsepower of the proxy. This added security allows fully encrypted communications over the Internet, while allowing standard sockets-based communications inside the firewall.

#### Dealing with Alternate Communication Mechanisms

##### Inherently Asynchronous Networks

Some networks are inherently asynchronous – as used herein, asynchronous means a network connection in which either end can open a connection, but neither can keep it open. Certain two-way paging wireless networks (Reflex, for instance) provide examples of such networks. Fig. 9 depicts a representative system in which requests meant for the end device [910] are sent to a wireless Network Operations Center (NOC) 920, where they are queued for delivery. Any response to the request is delivered asynchronously from the asset [910] via the NOC 920 to the server [940] via the Internet [930].

Requiring support for these types of networks requires the ability on the Enterprise to correlate requests and responses, as well as manage timeouts and status queries of responses. It also demands that any asset that handles incoming requests where a response is required must be able to send the response asynchronously.

Note that this same requirement is present when implementing a polling server, where the asset receives a request via polling and so must respond asynchronously.

### Active and Passive Communication

A critical capability is the ability to schedule communications with the device. There are basically two types of scheduled communications:

- 5           (1)     Active – The server initiates communication with the asset, *pulling* information from it. Note that the returned information can be returned synchronously (the most desirable in terms of performance and network traffic) or asynchronously (necessary to support certain networks, as described above, or to support communications that are inherently  
10           asynchronous, such as the scheduling of a long duration remote diagnostics routine).
- (2)     Passive – The asset maintains the schedule, and *pushes* information to the server based on that schedule or conditions within the asset. This is particularly useful when the asset is behind a firewall and can only  
15           initiate actions, but also may use a means such as the polling server discussed earlier to provide updates to the schedule.

### Application Modules

The Application Module (AM) is fundamental to the architecture of the A2B Application. Application Modules implement A2B business  
20     logic on both the enterprise and on the asset, as well as handle the Web Service interface between assets and the enterprise.

### The Enterprise Architecture

The invention utilizes a multi-tier distributed application software model. This consists of a *client tier*, a *middle tier*, and a *backend tier*.  
25     Fig. 10 illustrates this tiered architecture as follows.

The *client tier* [10] supports a variety of client types, both outside and inside of corporate firewalls. Typically, communication occurs across the Internet, whether from assets or human users, via the client

tier, including for example: users with web browsers; assets with components of this invention; and external applications using a Web Services integration model.

5 The *middle tier* [11] contains the application logic that provides the services requested by the client tier. Preferably, this is implemented with Enterprise JavaBeans (EJB) software components. Other software component models may be used as an alternative to EJBs.

10 The *backend tier* [12] supports access to existing information systems by means of standard APIs. A typical use is for access to a relational database.

### Runtime Environment

The invention also incorporates a Web Services runtime environment, as depicted in Fig. [11].

15 A client application 20 that wishes to use the functionality of an A2B Service creates a request message [21] that is sent over the network to a predefined Uniform Resource Locator (URL). The A2B Web Service broker 22 is associated with the URL and handles incoming requests.

20 When a request is received the protocol handler [23] is responsible for parsing the incoming data stream and constructing the appropriate message object for the protocol that is being used by the client. From the message, the destination Web Service is determined based on the contents of the SOAP message (see Fig. 4 for an example). The Web Service Registry is queried to find the class name that provides  
25 the implementation of the service 24. The default implementation of the Registry uses an XML based document named *wsdd.xml* (WSDD stands for “Web Services Deployment Descriptor”) that contains the mapping between a Web Service and the implementation class name. Other application server environments may use a different means of mapping a

Web Service to implementation software. The runtime will create a new instance of the service object, if it is not available in the cache of instantiated web services, and forward the message to the service for processing.

5           The invention also employs a custom-built Web Service  
Interceptor model [25] that can be configured to provide add-on services  
to support such things as logging and security transparent to a Web  
Service. Interceptors are invoked by the runtime both before and after a  
message is consumed, and can be configured either globally or on a per-  
10   service basis. This allows the software providing the service to be  
independent of how a particular implementation chooses to do security  
and logging.

Security is provided both through credentials (such as a UserID  
and Password) and through authentication token. The authentication  
15   token is generated upon a successful login and can then be used in  
subsequent transactions to reduce the security overhead. Other  
approaches to security are also covered, including digital certificates,  
private key pairs, and public/private keys.

#### Embedded Architecture

20           While the enterprise software for A2B provides full standalone  
application functionality, the embedded software strives to provide  
useful infrastructure for assets that communicate with the A2B enterprise  
application. This is because the main purpose of the asset collaborating  
in an A2B system is not typically A2B (a network printer's main  
25   purpose, for instance, is to make prints, not to provide remote  
diagnostics). Even embedded A2B gateways tend to be specific to the  
assets monitored (and/or the asset's native networks and protocols).

Providing a useful solution relevant for embedded systems is complicated by the heterogeneous nature of assets, with wide variability in the following areas:

- 5 (a) **Operating systems:** There are dozens of commercial operating systems available, including VxWorks, embedded Linux, Nucleus, OS/9, EPOC, Windows CE, custom (homegrown) RTOSes, and many more.
- (b) **Resource availability:** RAM/ROM constraints, power considerations, availability of non-volatile storage, etc. vary widely.
- 10 (c) **Processing capability:** ranging from 8-bit microcontrollers to [32]-bit microprocessors with Memory Management Units.
- (d) **User input capability:** ranging from reduced to none.
- (e) **Connectivity options:** potentially limited bandwidth (with varying pricing models). Ranging from tethered, untethered, dial-up, and full wireless.
- (f) **Programming language availability:** Java, C++, and C.
- 15 (g) **Existing software base:** existing web servers, XML parsers, and SNMP agents.

Because of these issues, the embedded software needs to be highly configurable as to which pieces of the solution are applicable to a given asset. Sometime we will only be able to provide very basic  
20 building blocks for A2B connectivity. In other cases (i.e., higher-end assets) we will be able to deliver robust application level support at both the Web Services layer and in application module functionality described as a microServer.

#### Framework vs. SDK

25 The distinction between an SDK (a.k.a. "toolbox") and a framework is important because a framework provides more capabilities

to the programmer. The A2B Device Framework not only provides a set of routines that provide functionality, but also provides the orchestration of those functions to solve a bigger problem.

5 A programmer can quickly use a handful of the SDK functions to create a “do something” application. To make that application solve a more complicated problem, though, the programmer spends much more time and requires understanding of a huge number of these API calls, and a bunch of code to actually call them. The framework has already solved many of these aspects of Web Service applications and supports a  
10 framework and philosophy for developing new applications. Specifically, the application-independent portion of the problem is solved in the framework, and need not be solved again.

A logical and convenient way to provide a framework is through an object oriented software design and implementation, using  
15 inheritance.

An example of this breakdown is the A2B protocol stack. The abstraction of a protocol stack is represented in C++, and provides a highly flexible mechanism for building, configuring, and using a protocol stack. The “guts” of the layers are written in C. The HTTP layer  
20 of the protocol stack is represented by a C++ class that adheres to the A2B protocol model, and is implemented using a library of C calls relying on “buffer-in” and “buffer-out”. These C calls can then be optimized and used by an asset relying solely on the SDK.

ANSI C and C++ have been chosen as the implementation  
25 language for A2B embedded systems support. Developing an object-oriented framework can be done more easily in C++ than in C, and elements of the framework that lean more toward “framework” than “SDK” are accomplished using C++. The C++ framework relies on a “toolbox” of code written in C. This C code can then be used in assets  
30 that do not support C++ (e.g. most 8-bit microcontroller-based assets).

## CLAIMS

1. Apparatus for connecting a remote machine to a central system by way of a network comprising:

a message generator for creating a message for transmission over the network,  
5 the message comprising information identifying the type of machine;  
a receiver for receiving and storing a unique identifier from a central system,  
the message generator subsequently creating messages using the unique  
identifier.

2. The apparatus of claim 1 in which the network is a TCP/IP network.

10 3. The apparatus of claim 1 in which the network is a wireless network.

4. The apparatus of claim 1 in which the connection is established through a gateway device that provides protocol or address translation.

5. The apparatus of claim 1 comprising memory in the central system for storing the unique identifier and information identifying the type of machine.

15 6. The apparatus of claim 1 in which the message is a registration message.

7. The apparatus of claim 6 in which the registration message includes: identifying information; information on the type of asset (e.g. Manufacturer, Product, Model, Version); network address and accessibility.

20 8. The apparatus of claim 6 comprising memory for storing a token indicating that the machine is registered, and inhibiting subsequent sending of registration messages.

9. The apparatus of claim 6 in which the registration message includes a non-unique identifier and the response from the server includes a unique identifier to be  
25 used by the asset in subsequent messages.

10. Apparatus for connecting a remote machine to a central system comprising:

a message generator for sending a registration message to a central system, the registration message including a unique identifier;

30 memory for storing a schedule;

a scheduler for periodically activating the message generator according to the stored schedule;

a receiver, activated for a predetermined time after the message generator is activated for receiving messages from the central system.

5           11.       The apparatus of claim 9 comprising a receiver for receiving an acknowledgement of the registration message and storing a token indicating that the machine is registered.

          12.       The apparatus of claim 11 comprising a controller for inhibiting the sending of subsequent registration messages in response to the token.

10          13.       The apparatus of claim 10 in which the receiver receives a schedule from a central system and stores the schedule in the memory.

          14.       The apparatus of claim 13 in which the receiver receives a schedule from a central system in response to a registration message.

15          15.       The apparatus of claim 10 in which the remote machine is a gateway device that provides protocol or address translation to further machines.

          16.       The apparatus of claim 15 in which the gateway maintains the schedule and interacts with the further machines as required to satisfy the schedule.

          17.       Apparatus for connecting a remote machine to a central system through a firewall that prevents incoming connections to the machine comprising:  
20           a message generator for sending a registration message to a central system;  
          memory for storing a schedule;  
          a scheduler for periodically activating the message generator according to the stored schedule for creating a temporary two way connection to a central system.

25          18.       The apparatus of claim 17 comprising a listener responsive to messages from the central system.

          19.       The apparatus of claim 18 in which the apparatus receives a schedule from the central system and stores the schedule in the memory.

30          20.       Apparatus for connecting a remote machine to a central system through a system that establishes solely transient connections to the machine and the central system comprising:

          a message generator for sending a registration message to a central system;

memory for storing a schedule;

a scheduler for periodically activating the message generator according to the stored schedule for sending messages to the central system, each message including a message identifier;

5 a listener receiving messages from the central system, each received message including a message identifier corresponding to the message identifier of one sent message

21. Apparatus for connecting a remote machine to a central system through a system that establishes solely transient connections to the machine and the  
10 central system comprising:

a message generator for sending a registration message to a central system;

a listener receiving messages from the central system, each received message including a message identifier

the message generator sending responsive messages to the central system, each  
15 responsive message including a message identifier corresponding to the message identifier of one received message;

22. A method of communicating between a server and an asset comprising the steps of:

queueing one or more request messages on the server;

20 logging the one or more request messages on the server;

sending a polling message from the asset to the server;

sending one of the one or more request messages to the asset in response to the  
polling message;

sending a responsive message from the asset to the server;

25 receiving the responsive message at the server and reconciling the responsive message with the logged request;

continuing to send request messages to the asset until the queue is empty.

23. The method of claim 22 in which the step of sending a polling message comprises sending polling messages at a predetermined interval.

30 24. The method of claim 22 comprising:

detecting an event at the asset requiring interactivity; and

sending one or more polling messages to the server in response to the fault.

25. The method of claim 24 in which the step of sending one or more polling messages comprises sending one or more polling messages at a second interval shorter than the predetermined interval.

5 26. The method of claim 25 in which the second predetermined interval is set by the server.

27. The method of claim 22 in which the server sends one or more of the queued messages to the asset in response to any message from the asset received by the server.

10 28. The method of claim 22 in which the server sends an indication of a queued message to the asset in response to various messages from the asset received by the server.

29. The method of claim 22 in which the message from the server includes a request for establishing an interactive session and the responsive message from the asset  
15 establishes an open connection through which subsequent messages are sent.

30. The apparatus of claim 22 in which the remote machine is a gateway device that provides protocol or address translation to further machines.

31. The apparatus of claim 30 in which the gateway maintains the schedule and interacts with the further machines as required to satisfy the schedule.

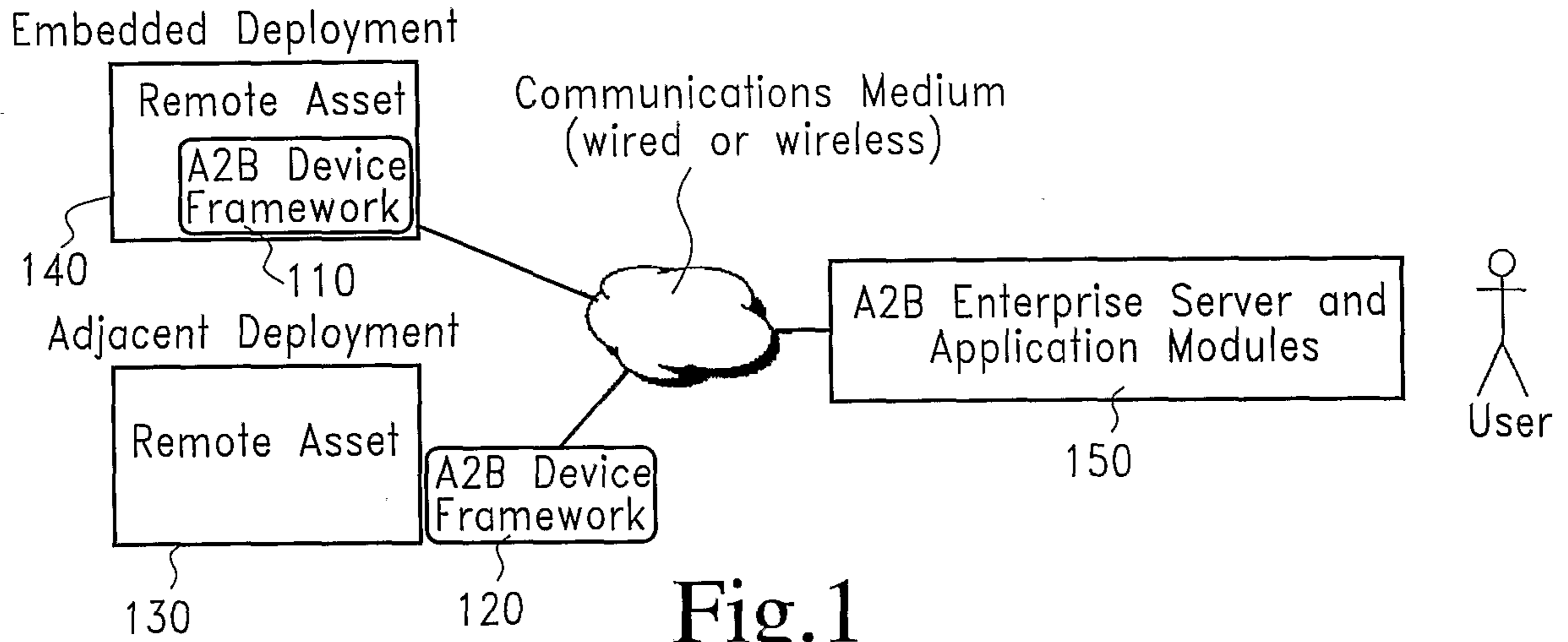

Fig. 1

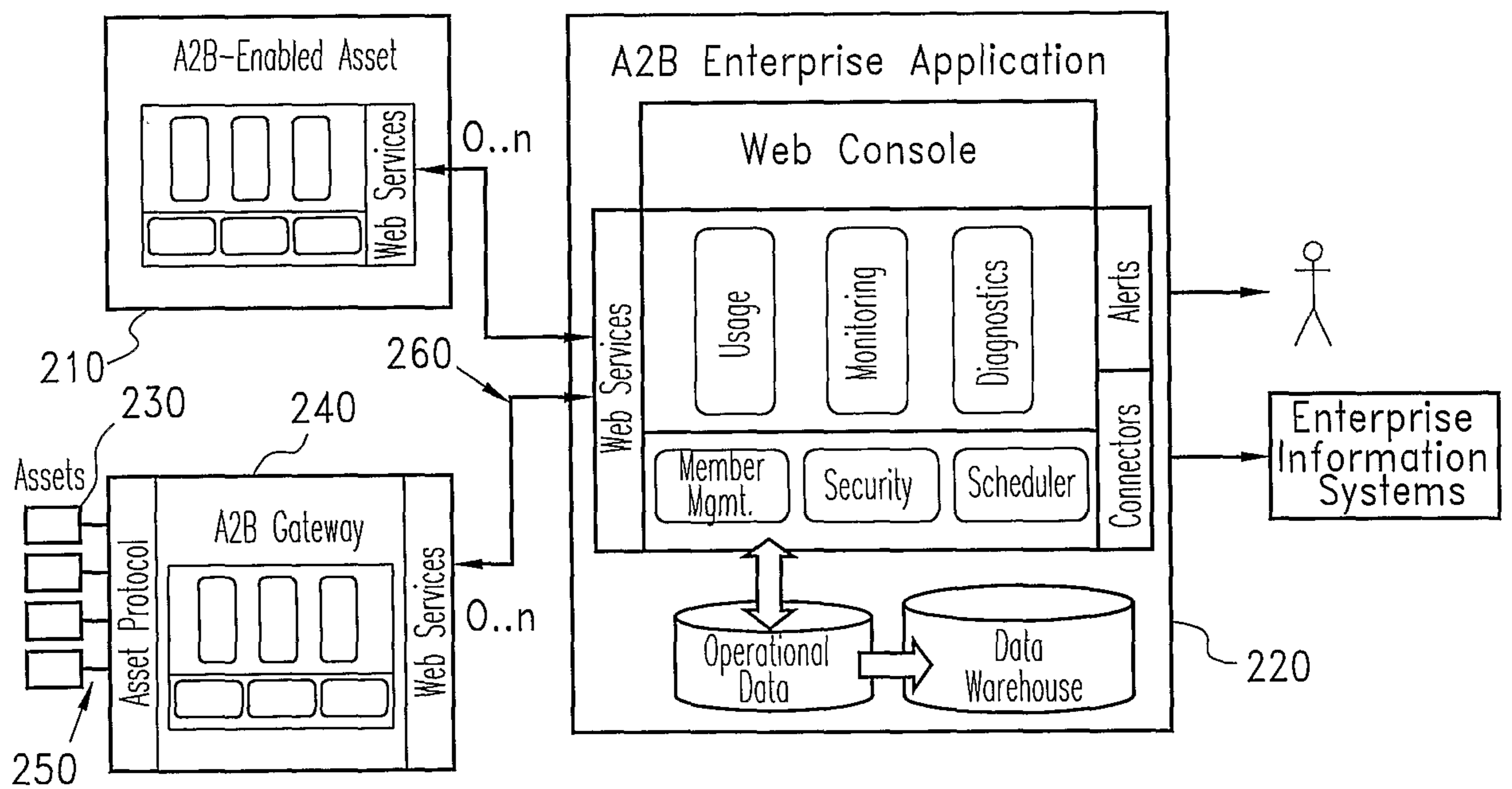

Fig. 2

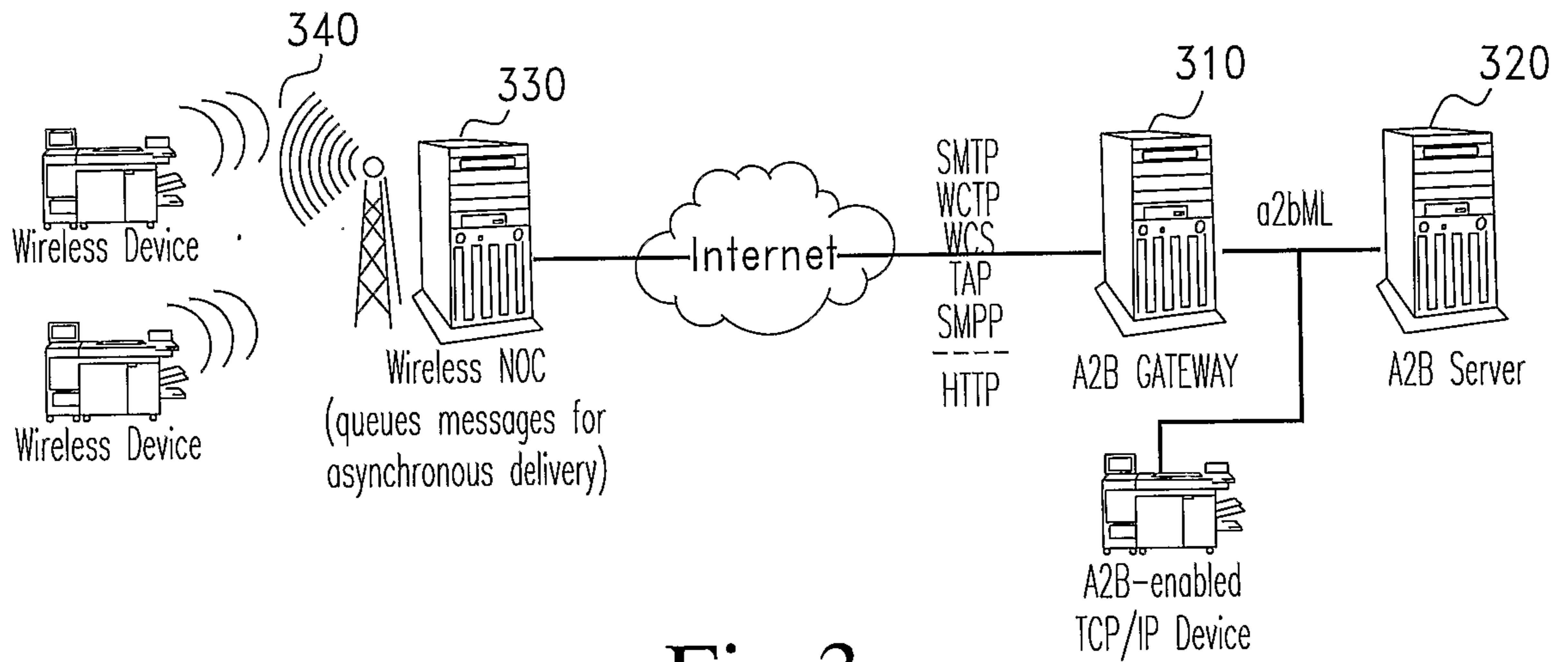

Fig.3

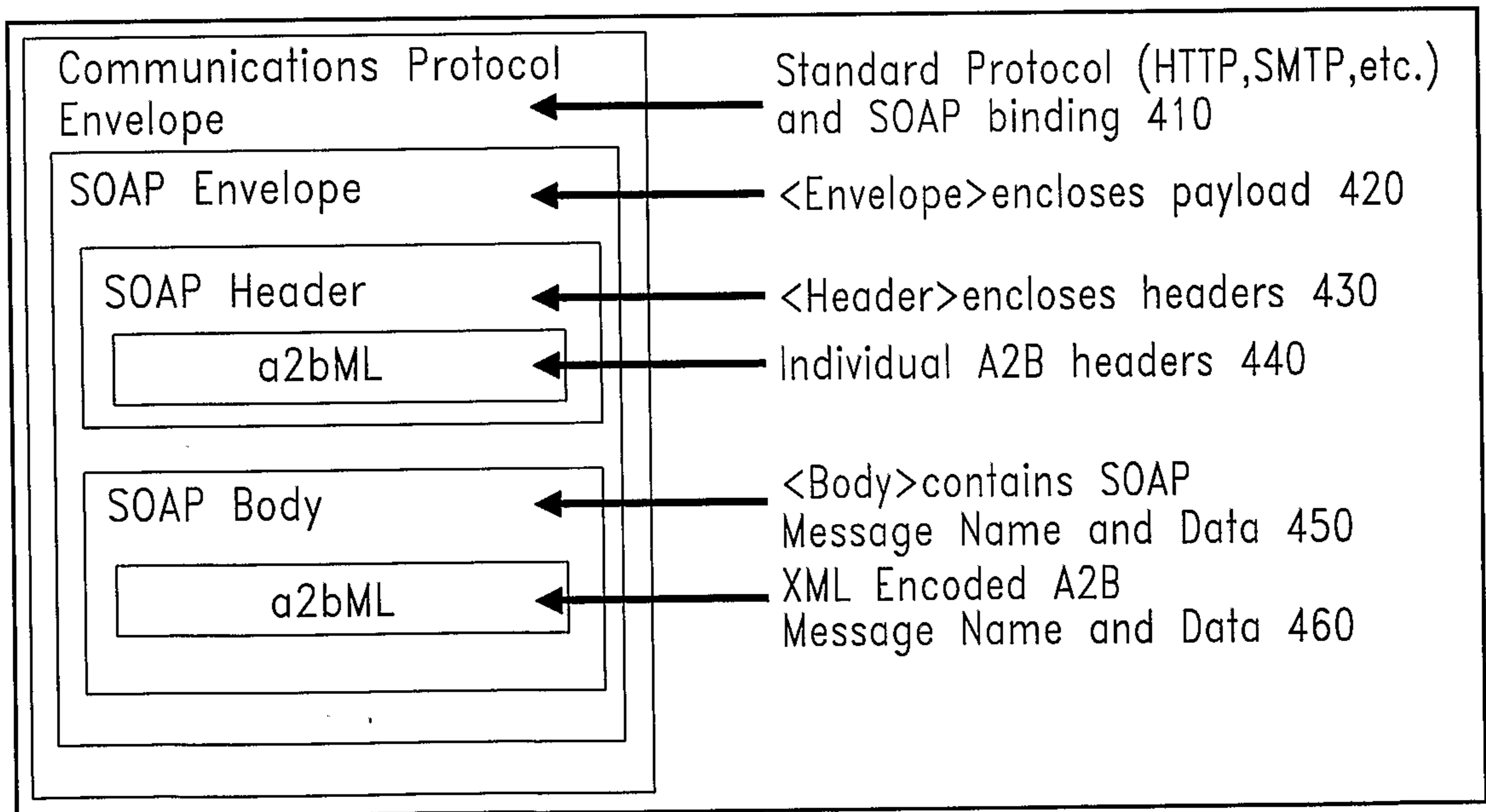

Fig.4

3/6

```

<SOAP-ENV:Envelope 520
  xmlns:SOAP-ENV=http://schemas.xmlsoap.org/soap/envelope/
  xmlns:xsd=http://www.w3.org/1999/XMLSchema/
  xmlns:xsi="http://www.w3.org/1999/XMLSchema/instance/">
  <SOAP-ENV:Header> 530
    <RequestHeader> 540
      <Operation>getProperties</Operation>
      <ServiceName>RemoteControlManagement</ServiceName>
      <SecurityContext>
        <AuthenticationToken>NTk1NDkTE2A6LTdmZlwmTA=</AuthenticationToken>
      </SecurityContext>
    </RequestHeader>
  </SOAP-ENV:Header>

  <SOAP-ENV:Body> 550
    <getProperties> 560
      <MemberId>a2bdevice2</MemberId>
      <WebServiceType>RemoteDiagnostics</WebServiceType>
      <PropertyNames>
        <Property name="Fan_Speed_1"></Property>
      </PropertyNames>
    </getProperties>
  </SOAP-ENV:Body>

</SOAP-ENV:Envelope>

```

**Fig.5a**  
**SOAP-Encoded Data**

getProperties.MemberId=a2bdevice2&getProperties.webServiceType=RemoteDiagnostics&getProperties.PropertyNames.Property@name=Fan%20Speed%201

**Fig.5b**  
**URL-Encoded Data**

g.M=a2bdevice2&g.W=RemoteDiagnostics&g.P.P@n=Fan%20Speed%201

**Fig.5c**  
**Compact-URL encoded data**

4/6

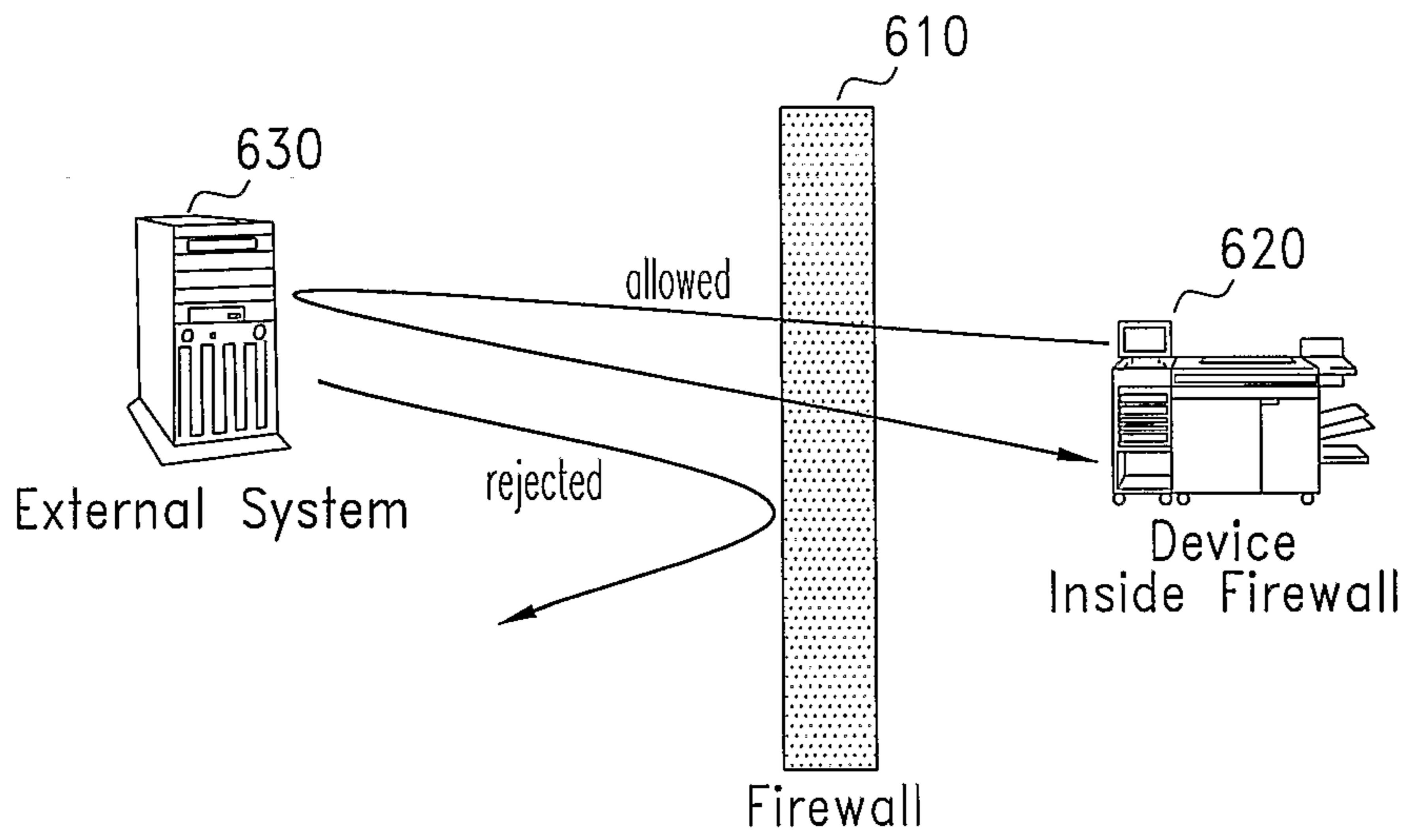

Fig.6

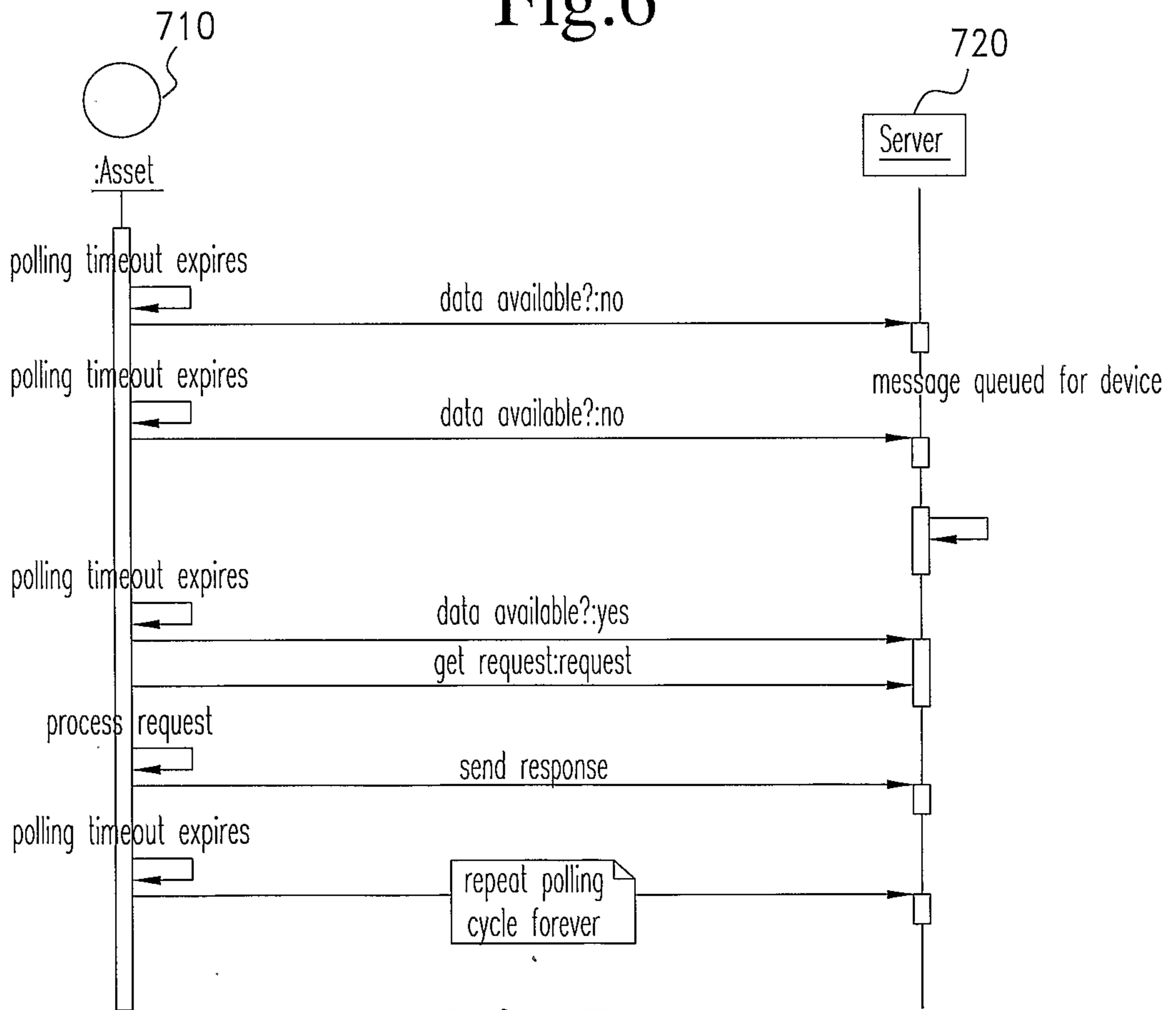

Fig.7

5/6

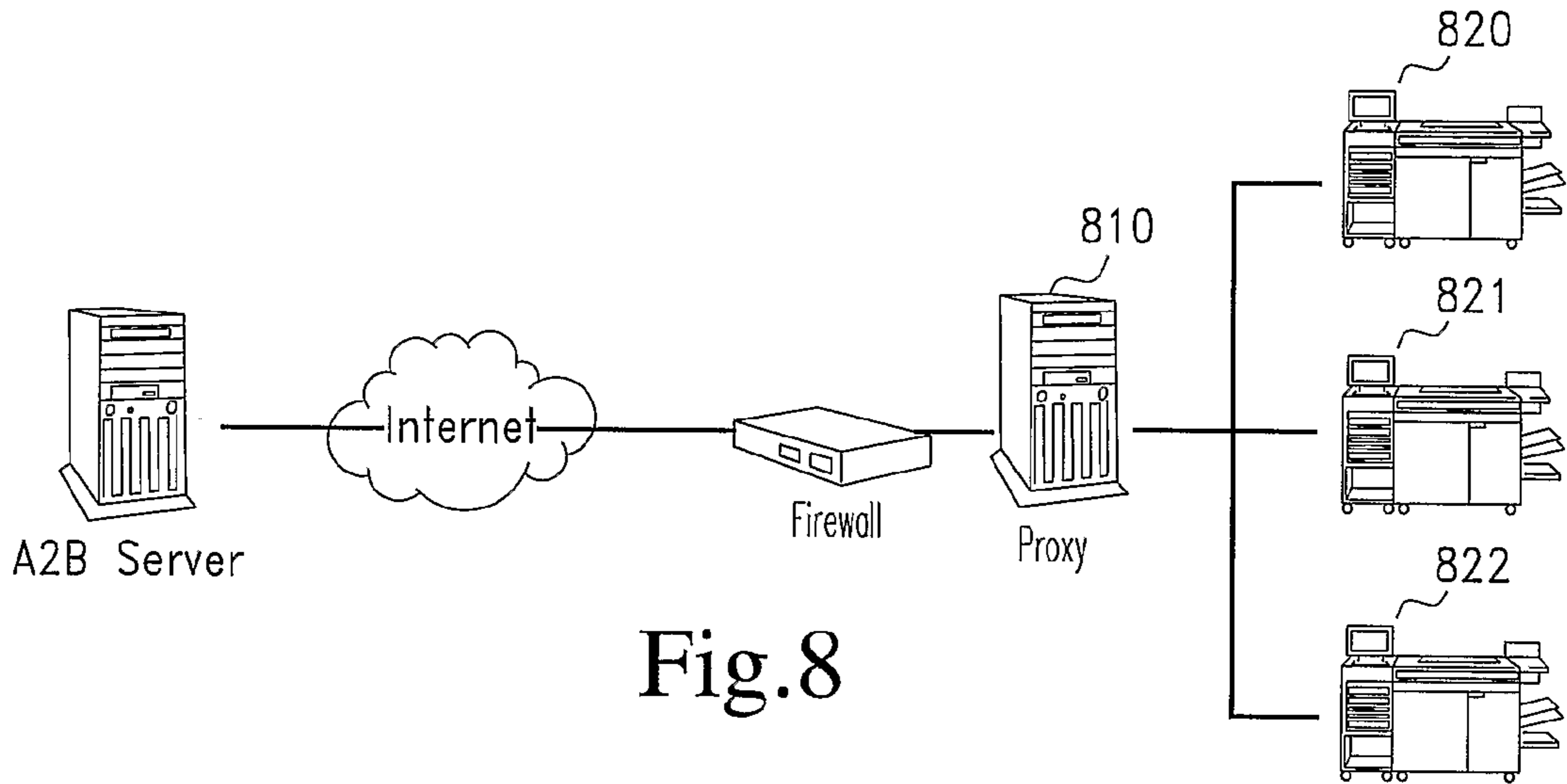

Fig.8

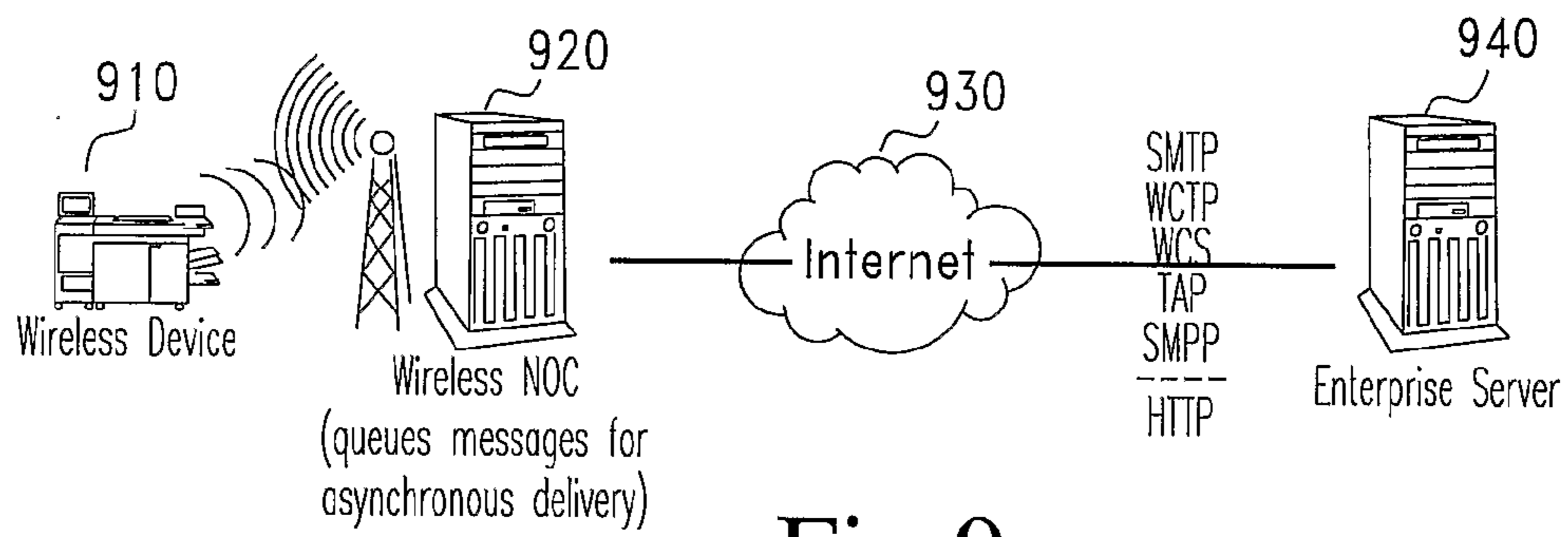

Fig.9

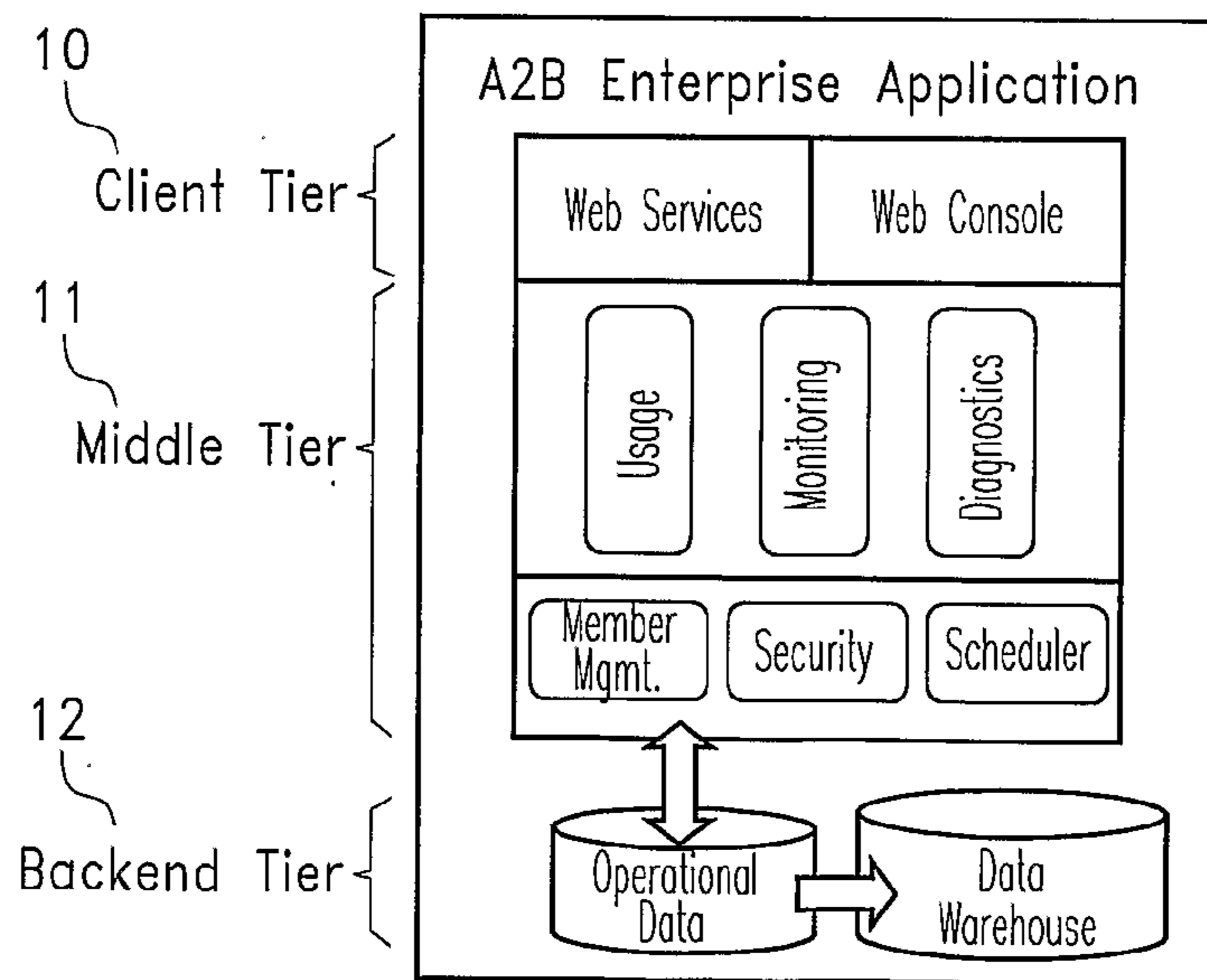

Fig.10

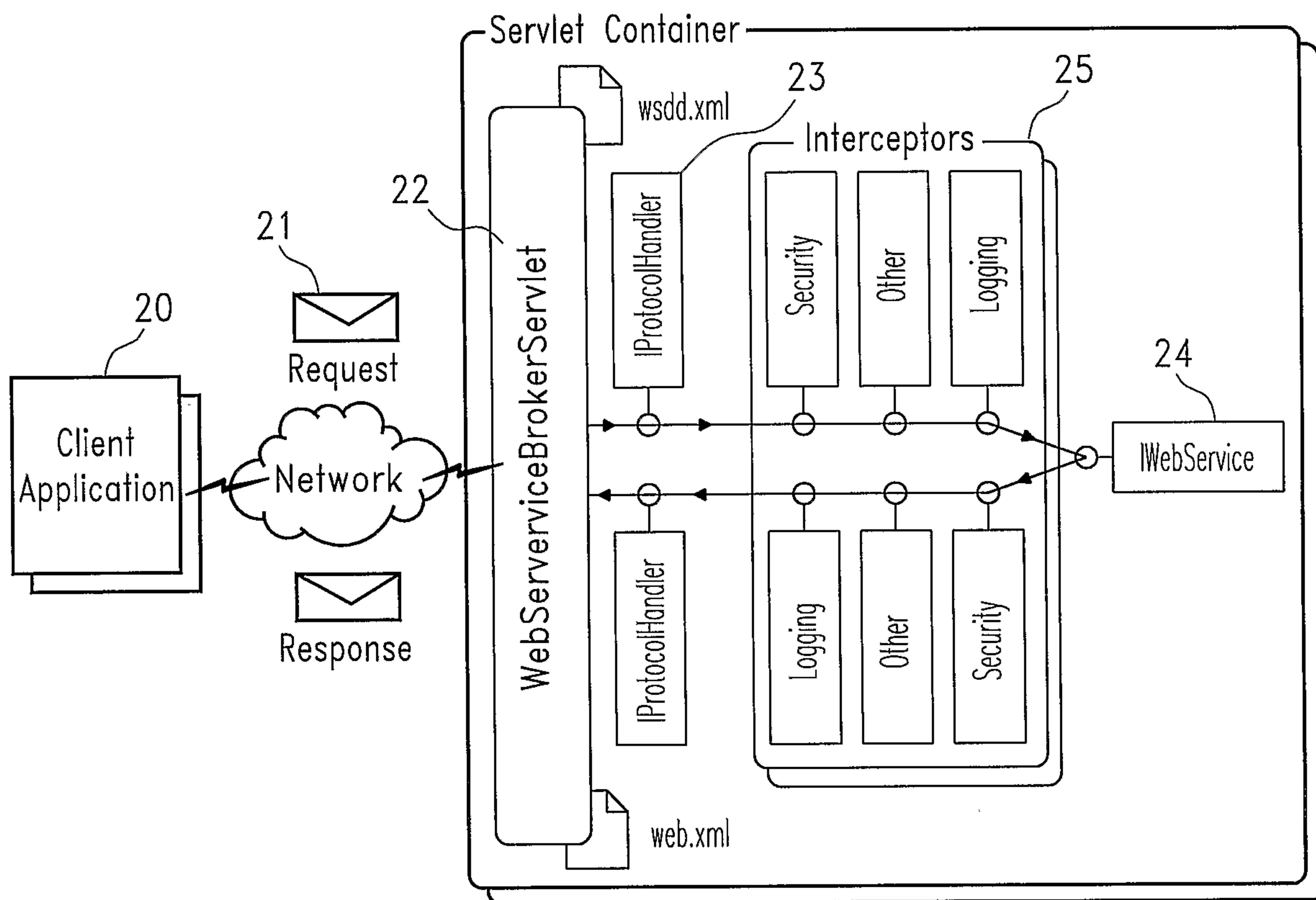

Fig. 11

