

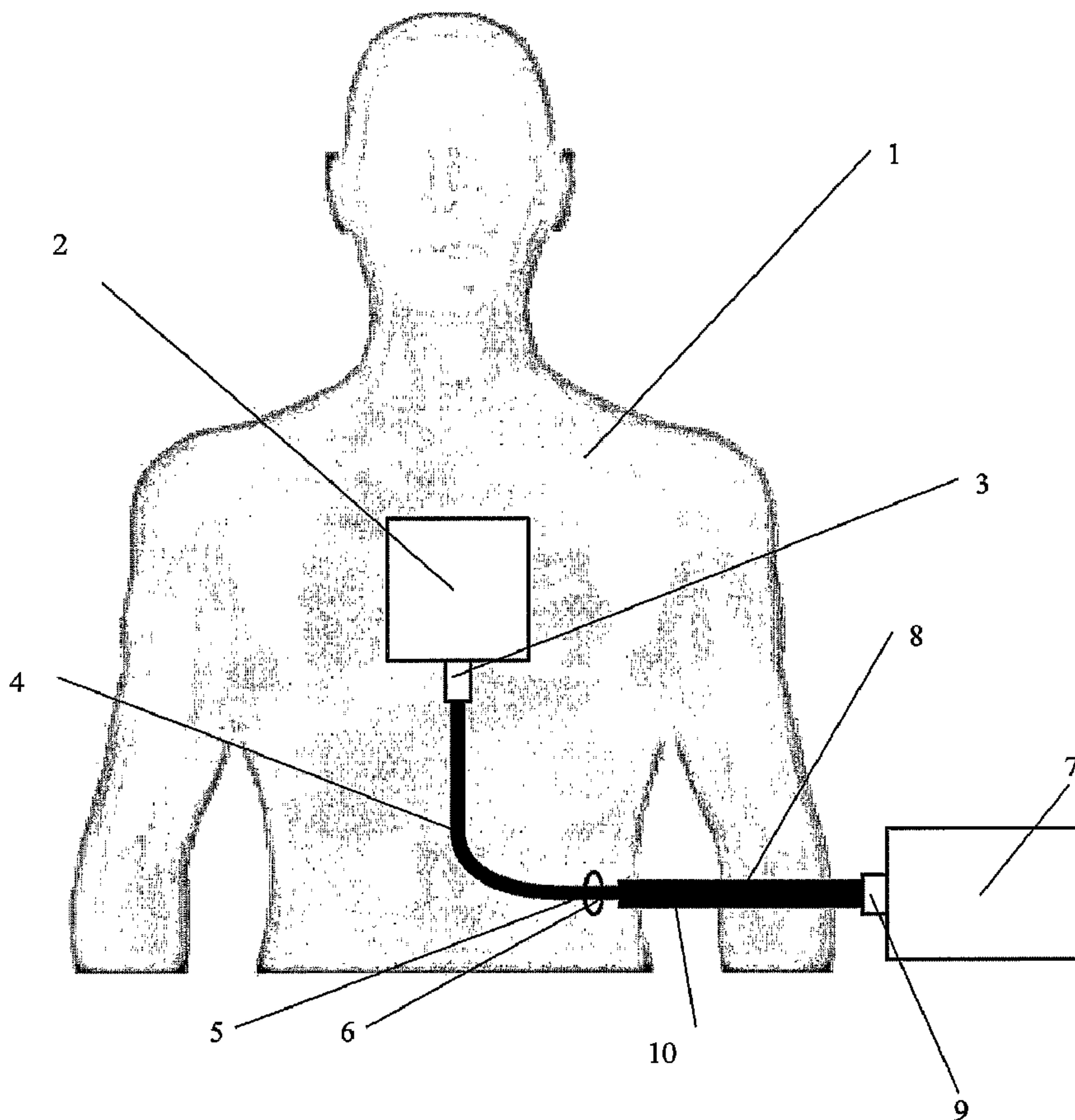

(86) Date de dépôt PCT/PCT Filing Date: 2005/02/02
 (87) Date publication PCT/PCT Publication Date: 2005/08/18
 (85) Entrée phase nationale/National Entry: 2006/08/03
 (86) N° demande PCT/PCT Application No.: AU 2005/000135
 (87) N° publication PCT/PCT Publication No.: 2005/075017
 (30) Priorité/Priority: 2004/02/04 (AU2004900538)

(51) Cl.Int./Int.Cl. *A61N 1/05* (2006.01),
A61F 2/48 (2006.01)
 (71) Demandeur/Applicant:
VENTRACOR LIMITED, AU
 (72) Inventeurs/Inventors:
AYRE, PETER JOSEPH, AU;
WOODARD, JOHN CAMPBELL, AU;
BEGG, JOHN DONALD, AU
 (74) Agent: MACRAE & CO.

(54) Titre : CONDUCTEUR PERCUTANE AMELIORE
 (54) Title: AN IMPROVED PERCUTANEOUS LEAD



(57) Abrégé/Abstract:

A percutaneous lead assembly (10) for supplying electrical signals to a medical device (2) implanted within a body of a patient (1). The lead assembly comprising a flexible elongate member having a first portion (8) adapted to remain external to the body of a

(57) **Abrégé(suite)/Abstract(continued):**

patient. The first portion having a first diameter and a second portion (4) joined to the first portion and adapted to extend through a hole (5) in a skin layer of the body of the patient. The second portion having a second diameter which is substantially smaller than the first diameter.

(12) INTERNATIONAL APPLICATION PUBLISHED UNDER THE PATENT COOPERATION TREATY (PCT)

(19) World Intellectual Property
Organization
International Bureau



(43) International Publication Date
18 August 2005 (18.08.2005)

PCT

(10) International Publication Number
WO 2005/075017 A1

- (51) International Patent Classification⁷: **A61N 1/05**, A61F 2/48
- (54) Agent: **HODGKINSON McINNES PAPPAS**; Level 3, 20 Alfred Street, Milsons Point, NSW 2061 (AU).
- (21) International Application Number: PCT/AU2005/000135
- (22) International Filing Date: 2 February 2005 (02.02.2005)
- (25) Filing Language: English
- (26) Publication Language: English
- (30) Priority Data:
2004900538 4 February 2004 (04.02.2004) AU
- (71) Applicant (for all designated States except US): **VENTRACOR LIMITED** [AU/AU]; 126 Greville Street, Chatswood, NSW 2067 (AU).
- (72) Inventors; and
- (75) Inventors/Applicants (for US only): **AYRE, Peter, Joseph** [AU/AU]; 31A Devonshire Street, Crows Nest NSW 2065, Australia (AU). **WOODARD, John, Campbell** [AU/AU]; 27 Wareemba Avenue, Thornleigh, NSW 2120 (AU). **BEGG, John, Donald** [AU/GB]; 1 Loveday Close, Chrishall nr Royston, Herts SG8 8UA (AU).
- (81) Designated States (unless otherwise indicated, for every kind of national protection available): AE, AG, AL, AM, AT, AU, AZ, BA, BB, BG, BR, BW, BY, BZ, CA, CH, CN, CO, CR, CU, CZ, DE, DK, DM, DZ, EC, EE, EG, ES, FI, GB, GD, GE, GH, GM, HR, HU, ID, IL, IN, IS, JP, KE, KG, KP, KR, KZ, LC, LK, LR, LS, LT, LU, LV, MA, MD, MG, MK, MN, MW, MX, MZ, NA, NI, NO, NZ, OM, PG, PH, PL, PT, RO, RU, SC, SD, SE, SG, SK, SL, SY, TJ, TM, TN, TR, TT, TZ, UA, UG, US, UZ, VC, VN, YU, ZA, ZM, ZW.
- (84) Designated States (unless otherwise indicated, for every kind of regional protection available): ARIPO (BW, GH, GM, KE, LS, MW, MZ, NA, SD, SL, SZ, TZ, UG, ZM, ZW), Eurasian (AM, AZ, BY, KG, KZ, MD, RU, TJ, TM), European (AT, BE, BG, CH, CY, CZ, DE, DK, EE, ES, FI, FR, GB, GR, HU, IE, IS, IT, LT, LU, MC, NL, PL, PT, RO, SE, SI, SK, TR), OAPI (BF, BJ, CF, CG, CI, CM, GA, GN, GQ, GW, ML, MR, NE, SN, TD, TG).
- Published:
— with international search report

[Continued on next page]

(54) Title: AN IMPROVED PERCUTANEOUS LEAD

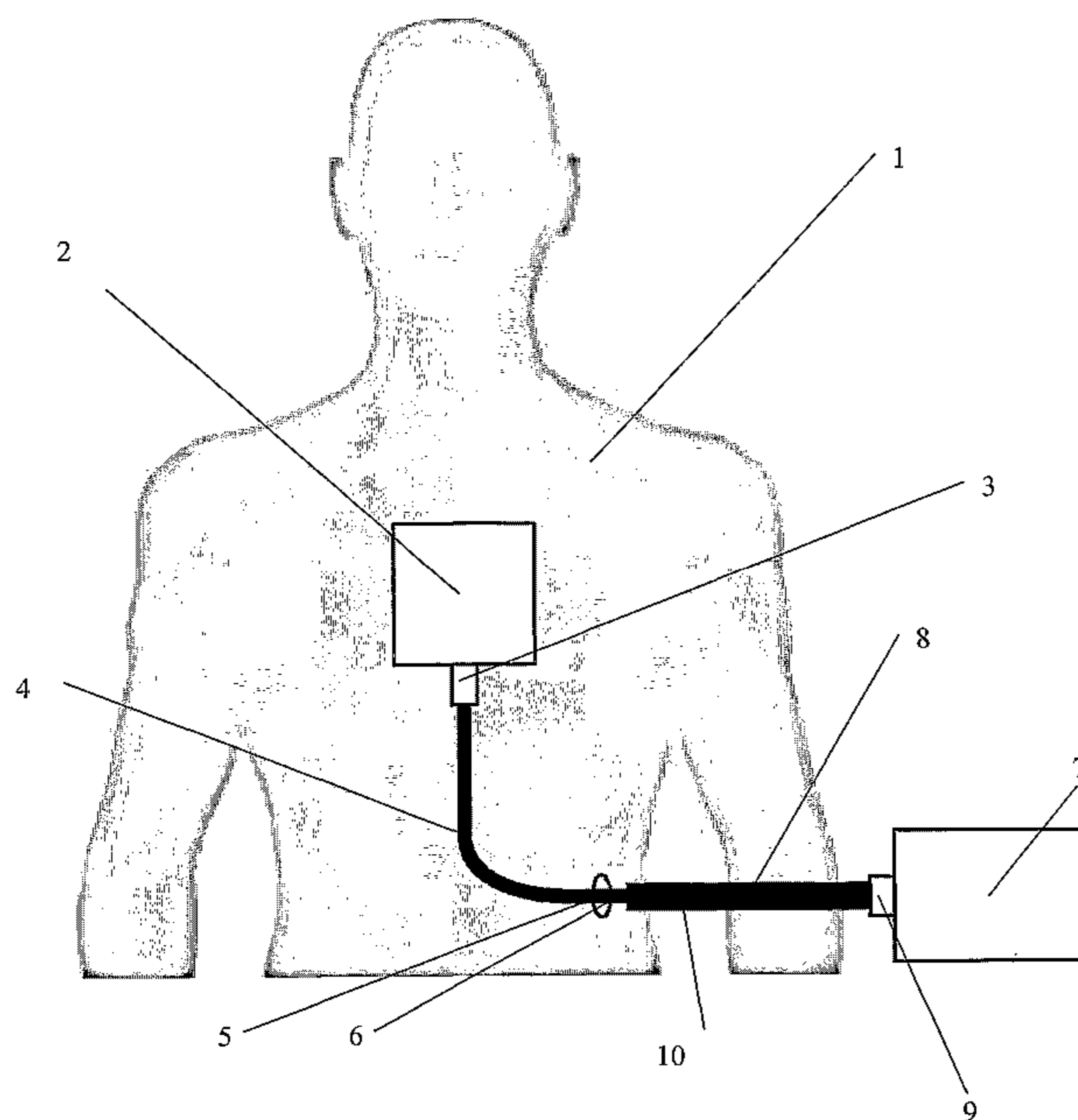

(57) Abstract: A percutaneous lead assembly (10) for supplying electrical signals to a medical device (2) implanted within a body of a patient (1). The lead assembly comprising a flexible elongate member having a first portion (8) adapted to remain external to the body of a patient. The first portion having a first diameter and a second portion (4) joined to the first portion and adapted to extend through a hole (5) in a skin layer of the body of the patient. The second portion having a second diameter which is substantially smaller than the first diameter.

WO 2005/075017 A1

WO 2005/075017 A1



For two-letter codes and other abbreviations, refer to the "Guidance Notes on Codes and Abbreviations" appearing at the beginning of each regular issue of the PCT Gazette.

AN IMPROVED PERCUTANEOUS LEAD

Field of Invention

The present invention relates to an improved percutaneous lead and improved
5 means of implanting said lead for use with implantable medical devices.

Background

A substantial amount of medical research is currently being aimed at treating
disease by the use of implantable medical assist devices. Some of these implantable
10 medical assist devices passively assist patient's body functions. Examples of passive
medical devices include: artificial cannulation to replace or assist failing arteries or
veins; and various artificial implants such as artificial blood implants. Other
implantable medical devices are called active implantable medical devices. These
active implantable medical devices generally require a power source or supply to
15 function or aid the patient's normal bodily functions. These active implantable medical
devices may include pacemakers, implantable pumps, neuro-stimulators, and cochlear
implants.

There has been a long felt need to be able to safely and reliably implant active
medical assist devices and to avoid long term patient problems associated with the use
20 of such devices. One of the common problems encountered with the use of these
devices is that a substantial proportion of these generally require a means of
communicating electrical information, data, and/or power with the external environment
outside the body of a patient, when implanted.

The traditional solution for this problem is to connect the implanted active
25 medical device to a percutaneous lead. This lead preferably extends from the implanted

device within the patient's body, through the skin layer of a patient then to a controller, computer or power circuit (external to the patient's body). This traditional configuration may lead to increased risk of bacterial infection and reduced quality of life for the patient. Additionally there is a risk that said lead may be accidentally
5 severed by the patient and this raises safety and reliability concerns relating to the traditional use of percutaneous leads.

In the past, there have been other inventions aimed at reducing or eliminating the need for a permanent wound at the lead's exit site in the patient's skin layer. These other inventions used RF transceiver devices mounted internally and externally in
10 relation to the patient to relay electrical signals without the need for a hole in the patient's skin. These RF transceiver devices may cause significant damage or physical harm to the patient due to: adverse heating events to the patient's internal organs, reductions in a patient's quality of life, burns, discomfort and also transmission efficiency problems with the quality of the data and power transceived by such systems.
15 All of these problems lead to inevitable safety and reliability relating to use of such systems by patients.

The present invention aims at addressing or ameliorating at least some of the aforementioned problems of the prior art.

20 **Brief description of the invention**

The present invention, in a broad form, provides a percutaneous lead assembly for supplying electrical signals to a medical device implanted within a body of a patient, said lead assembly comprising a flexible elongate member having a first portion adapted to remain external to the body of a patient, said first portion having a first
25 diameter; and a second portion joined to said first portion and adapted to extend through

a hole in a skin layer of the body of the patient, and wherein said second portion having a second diameter which is substantially smaller than said first diameter.

Preferably, said first portion may include a shielding layer. Additionally, at least a segment of said second portion may be covered with a textured surface.

5 Preferably, said first portion and said second portion may be joined by connectors and said percutaneous lead assembly may include a lead restraint.

According to a further broad form of the present invention, an external lead restraint for use with a percutaneous lead, wherein said lead is implanted within a body of a patient and extends through a hole in the patient's skin and characterised in that an
10 excess length of lead is releasably secured near to the hole by releasable securing means affixed to the patient's skin.

In another broad form of the present invention, a percutaneous lead assembly for supplying electrical signal to a medical device implanted within a body of a patient, wherein said lead assembly has a flexible elongate member including a first unshielded
15 portion that extends through a hole in a skin layer of the body of the patient; and a second shielded portion which is joined to said first unshielded portion at a site external to the body of the patient.

Brief description of the drawings

20 Embodiments of the present invention will now be described with reference to the accompanying drawings wherein:

Figure 1 shows a schematic view of a first preferred embodiment of the present invention, in situ;

Figure 2 shows a cut away side view of a portion of a preferred embodiment;

25 Figure 3 shows a cut away side view of a portion of a preferred embodiment;

Figure 4 shows a cross sectional side view of an embodiment;

Figure 5 shows a top view of a preferred embodiment; and

Figure 6 shows a cross sectional side view of a portion of the strain terminator mechanism shown in figure 5.

5

Brief description of the preferred embodiments

The present invention generally relates to an improvement to percutaneous lead assemblies. A first preferred embodiment of this invention is shown in Figure 1. In this embodiment, a patient 1 is implanted with a medical assist device 2 to assist or enhance the patient's body function. Preferably, this medical assist device may be active or passive and may require uni- or bi-directional data, instructions, and/or power in the form of electrical signals from the external environment. Preferably, these electrical signals may be communicated by an external controller 7. Please note that it may be preferable to use this embodiment in conjunction with an implantable blood pump or a left ventricle assist device.

In the embodiment shown in Figure 1, the external controller 7 is in electrical communication with the implanted medical device 2 by the use of the flexible percutaneous lead assembly 10. The external controller 7 is or may include any of the following devices: batteries, power supply, hardware controller, personal computer, microcontroller, and/or microprocessors.

The connection formed by the percutaneous lead assembly 10 may allow for the transmission and reception of electrical signals. The lead assembly 10 may allow for a continuous electrical link between the medical device 2 and the controlling device 7 by the use of continuous wiring (not shown in Figure 1) running through the core of the lead assembly 10. Preferably, the lead assembly 10 extends from the medical device 2,

implanted within the body of the patient 1, through a hole or aperture 5, made by a physician or doctor, to the controlling device 7.

The preferred percutaneous lead assembly 10 may also include: two ends, two connectors 3 & 9, wherein one connector is connected to either end of the lead assembly 10 and wherein preferably each connector 3 & 9 is designed to mate with a respective corresponding connector on the medical device 2 and/or the controlling device 7.

The percutaneous lead assembly 10 has a first portion 8 and a second portion 4. The second portion 4 may extend from the first connector 3 through the aperture 5 and join with the first portion 8. Preferably, the section of the lead referred to as the second portion 4 may include regions coated with a textured surface. This textured surface may be produced by coating the region of the lead with velour or Dacron™. These types of coating materials promote ingrowth of the patient's cells into the surface of the textured surface and assist in anchoring lead assembly 10 within the patient's body 1. It is also preferred to only coating the lead portions, where necessary to achieve the desired amount of ingrowth or anchoring within the body 1.

Additionally, the second portion 4 extends out from the patient's body 1 through the hole 5. This extension past the hole 5 is shown by relatively thin region 6. Preferably, region 6 does not include a textured coating. Please note that hole 5 may also be referred to as a permanent exit wound.

In this embodiment, the relatively thin region 6 is integrally joined to the relatively thick region of first portion 8. The first portion 8 is also joined to a connector 9. When in use, the connector 9 may be connected to a controlling device 7.

The second portion 4 passing through the exit wound 5 generally allows the exit wound to be of a substantially smaller diameter than otherwise would be the case if the lead assembly was of a uniform thickness. This reduction in the size of the exit wound

may lessen the trauma experienced by patient 1 during and after implantation; as well as reducing the chance of infection at or near to the exit wound region. The relatively thick region of first portion 8 of the lead assembly 10 may allow for increased wear resistance of the external portion of the lead as well as providing extra shielding for the wiring within the assembly 10.

Please also note that the first portion 8 may be constructed by wrapping or coating the relatively thin regions that extend externally from the patient's body and effectively protect or reinforce the external portion of the lead assembly 10. Additionally, a protective sheath may be used to the first portion 8 to achieve a similar effect of protecting the external portion of the wiring assembly.

A preferred embodiment shown in Figure 2 depicts a cross sectional cut away view of the first portion 8 of lead assembly 10. In this embodiment, the first portion 8 of the lead assembly 10 may include: an outer protective sheath 11, an inner protective sheath 12, an electromagnetic shielding layer 13, and a wire bundle 14.

Preferably, the outer protective sheath 11 is constructed from a tough but flexible material that is preferably wear resistant and/or cut resistant. The outer protective sheath 11 may be constructed of polyurethane material. Please note that the materials use to construct the first portion 8 of the lead assembly do not need to be biocompatible and may even be toxic during implant conditions. This is because the first portion 8 is preferably not implanted within the body of the patient.

The inner protective sheath 12 provides additional wear resistance. Generally, the inner protective sheath 12 may function to support the general shape and configuration of the first portion 8. Preferably, the inner protective sheath 12 is flexible yet resistant to wear. In some preferred embodiments of the present invention, the inner protective sheath 12 may be constructed of silicone rubber or a similar polymer known

as Nusil™. Silicone and Nusil™ also have the advantage that they are relatively transparent and enable easy inspection as to the condition and quality of the inner protective sheath 12.

The electromagnetic shielding layer 13 may be included within the structure of the first portion 8 of the lead assembly. This layer may function to prevent electromagnetic interference from the outside environment interfering with the electric signals being communicated by the lead assembly, when in use. The electromagnetic shielding layer 13 is preferably constructed from braided stainless steel and this is because metals generally provide the most efficient electromagnetic shielding. Additionally, stainless steel braid is relatively wear resistant and cut resistant, which prevents accidental breakage by a patient, user or doctor. Also, stainless steel is generally resistant to oxidation or rusting and is therefore preferred for long term applications in vigorous environments and is also suitable for implantation.

Within the electromagnetic shielding layer 13 may be a wire bundle 14 which contains the wires to act as an electrical conduit for the lead assembly. The wire bundle is generally assembled by inter weaving several insulated wires 15 with each other and a wiring strain relief 17. The position of the wires and the mechanical strain relief set in place using second layer of silicone or Nusil™. Preferably, the lead assembly 10 includes three wires, but any number of wires are possible. An increase in the number of wires will increase the overall minimum diameter of the lead assembly, therefore it is preferred to include a minimum amount of insulated wires to provide functionality to the implantable medical device for which the lead assembly is to cooperate.

Preferably, the wiring strain relief 17 is constructed from 2 Kevlar™ cords with a combined approximate breaking strain of 630N. Additionally, the wires 16 within the

wire bundle 14 should be separately insulated preferably using Perfluoroalxyoxy ('PFA') insulation 15.

A further embodiment is shown in figure 3. This figure depicts the second portion 4 of the lead assembly 10. The second portion 4 may include a textured outer surface 19, outer protective layer 21, and a wire bundle 22.

Preferably, at least a segment of second portion 4 is covered with a textured outer surface 19. The textured outer surface 19 may be constructed of velour or Dacron™. This textured surface may permit a patient's body to ingrow into regions of the lead assembly covered with this textured surface 19. It may also be noted that the textured surface preferably only coats regions of the lead assembly which necessarily must be anchored to the patient's body. Portions of the relatively thin region 20 which extend externally from the patient's body may not require a textured surface for this reason.

The outer protective layer 21, in this embodiment, performs a similar function of the inner protective sheath 12 described in relation to Figure 2. The outer protective layer 21 adds further wear resistance, may be flexible, may be substantially biocompatible and may be suitable for implantation. The outer protective layer 21 may be constructed of silicone or Nusil™.

Beneath the outer protective layer 21 preferably is a wire bundle 22. This wire bundle 22 may include: three wires 25 (which are insulated preferably by PFA 23), a wiring strain relief 24, and some silicone or Nusil™ to provide dimensional support. The wire bundle 22 may be constructed in similar manner to the wire bundle 14 depicted in Figure 2.

The smaller or thinner diameter of second portion 4 may also increase the anchoring effect of the textured surface, as the thinner region may allow for better tissue

integration. The smaller or thinner diameter may be accomplished by the removal of outer protective sheath 11 and the shielding layer 13. The shielding layer 13 may not be required for communicating electrical signals with a medical device, particularly in cases where the length of the relatively thin region of the lead assembly is relatively short when compared against the exposed regions of the lead assembly 10 which are external to the patient, such as the first portion 8.

A further embodiment is shown in Figure 4, wherein the lead assembly 10 is implanted within a patient. Please note that similar numerical labelling to Figure 1 has been used in relation to Figure 4. The skin layer 26 of a patient is shown with a hole, aperture or exit wound 5. Preferably, the lead assembly 10 passes through the hole 5. This embodiment depicts the lead assembly 10 including a relatively thin region 6 and the thicker first portion 8 external of the body of the patient. Wires 30 pass through the centre of the lead assembly and allow electrical communication to be achieved between an external device and an internally implanted medical device.

Preferably, the internal portion of the lead assembly includes the relatively thin region 6 coated with a textured surface 4.

Additionally, the size of the hole 5 is minimised because of the thickness of the relatively thin region 6. This minimisation reduces the probability of infection and promotes wound healing by the patient's body.

A further embodiment is shown in Figure 5. In this embodiment, the lead assembly 10 includes a strain terminator mechanism. The Figure 5, using similar numerical referencing as Figure 1 & 4, shows the external surface of the patient's skin 26 at a site where the lead assembly 10 exits the body. The lead assembly, in this embodiment includes of a relatively thin region 6 and a first portion 8, joined by two

connectors 33 & 34. Preferably these connectors mate to form a connection and allow electrical communication of the wires within the lead assembly.

Preferably, connectors 33 and 34 are submersible and/or water resistance. This water resistance feature will allow the patient to bath, shower or swim in relative safety
5 in regard to medical device failure or electrocution. This may be achieved by including two 'O' rings within the connectors so as to provide a relatively good seal against water penetration. The connectors preferably are made of wear resistance plastic material which is lightweight and unlikely to cause discomfort to the patient. It may also be preferable to allow the connectors to be secured together, when in use, by a screw &
10 thread means.

It may also be preferable for the connectors 33 & 34 to allow for easy replacement of the first portion 8, in situations of accidental breakage without requiring the patient to undergo substantive invasive surgery. This may be achieved by disconnecting the connectors 33 & 34 and then attaching a replacement first portion 8 of
15 the lead assembly.

The strain terminator mechanism includes: a loop of redundant lead 37 and a lead restraint 35. In this embodiment, the loop 37 is formed from the relatively thin region 6 of the lead assembly 10 extending from the hole 5 in the patient's skin layer. The strain relief mechanism is arranged so that if the lead assembly is accidentally or
20 otherwise pulled, the lead assembly is not pulled from the patient's body. Obviously, if the lead assembly was pulled or jerked suddenly the net result may be to cause serious damage to the patient's skin layer and or internal organs. Additionally, the implanted medical device, which the lead assembly is connected internally to, may also be damaged by such an accident or incident.

Preferably, in situations where the lead assembly is pulled the lead restraint 35 would function to dampen the stresses otherwise experienced by hole 5. The lead restraint 35 preferably holds the lead assembly and may at the user's discretion release the lead assembly. The loop 37 of lead assembly functions to supply additional lead if the lead is pulled through the lead restraint 35. The loop 37 serves a backup and provides slack to the lead assembly between the hole 5 and lead restraint 35.

Please note that the loop 37 is not required to be in a loop formation, any redundant lead length (such as a coil of lead) between the lead restraint 35 and the hole 5 will serve a similar function. However the loop formation of the redundant length of lead is generally preferable for presentation or aesthetic reasons.

The embodiment is shown in Figure 6, depicts a preferred lead restraint 35 is depicted. This preferred lead restraint 35 includes: a flexible strip 40, interlocking Velcro™ segments 43 & 44 and adhesive 41.

Preferably, the lead restraint 35 is constructed by gluing a portion of the flexible strip 40 to the surface skin layer 26 of a patient. This may be accomplished by applying adhesive 41 to the locations depicted in Figure 6. Attached to the opposed surface of flexible strip 40, which was glued to the patient's skin, may be attached at least two segments of interlocking and complementary Velcro™ 43 & 44 regions. This arrangement preferably allows the flexible strip 40 to fold and allow the complementary Vecro™ 43 & 44 regions to interlock and/or connect.

Preferably, the relatively thin region 6 of the lead assembly 10 is positioned between the two interlocking layers of Velcro™ 43 & 44. The relatively thin region 6 may be secured in place by the lead restraint 35. Preferably, the interlocking regions 43 & 44 secure the relatively thin region 6 firmly enough so as to restrain the lead from

accidental stress induced by pulling or stretching. Please note that the lead restraint 35 may be positioned to also restrain the first portion 8.

Various modifications and alterations are possible within the spirit of the foregoing specification without departing from the scope of this invention.

THE CLAIMS DEFINING THE INVENTION ARE AS FOLLOWS:-

1. A percutaneous lead assembly for supplying electrical signals to a medical device implanted within a body of a patient, said lead assembly comprising a flexible elongate member having a first portion adapted to remain external to the body of a patient, said first portion having a first diameter; and a second portion joined to said first portion and adapted to extend through a hole in a skin layer of the body of the patient, and wherein said second portion having a second diameter which is substantially smaller than said first diameter.
2. The percutaneous lead assembly as claimed in claim 1, wherein said first portion includes a shielding layer.
3. The percutaneous lead assembly as claimed in claim 1 or claim 2, wherein at least a segment of said second portion is covered with a textured surface.
4. The percutaneous lead assembly as claimed in claim 1, wherein said first portion and said second portion are joined by connectors.
5. The percutaneous lead assembly as claimed in claim 1, wherein said percutaneous lead assembly includes a lead restraint.
6. An external lead restraint for use with a percutaneous lead, wherein said lead is implanted within a body of a patient and extends through a hole in the patient's skin and characterised in that an excess length of lead is releasably secured near to the hole by releasable securing means affixed to the patient's skin.
7. A percutaneous lead assembly for supplying electrical signal to a medical device implanted within a body of a patient, wherein said lead assembly has

a flexible elongate member including a first unshielded portion that extends through a hole in a skin layer of the body of the patient; and a second shielded portion which is joined to said first unshielded portion at a site external to the body of the patient.

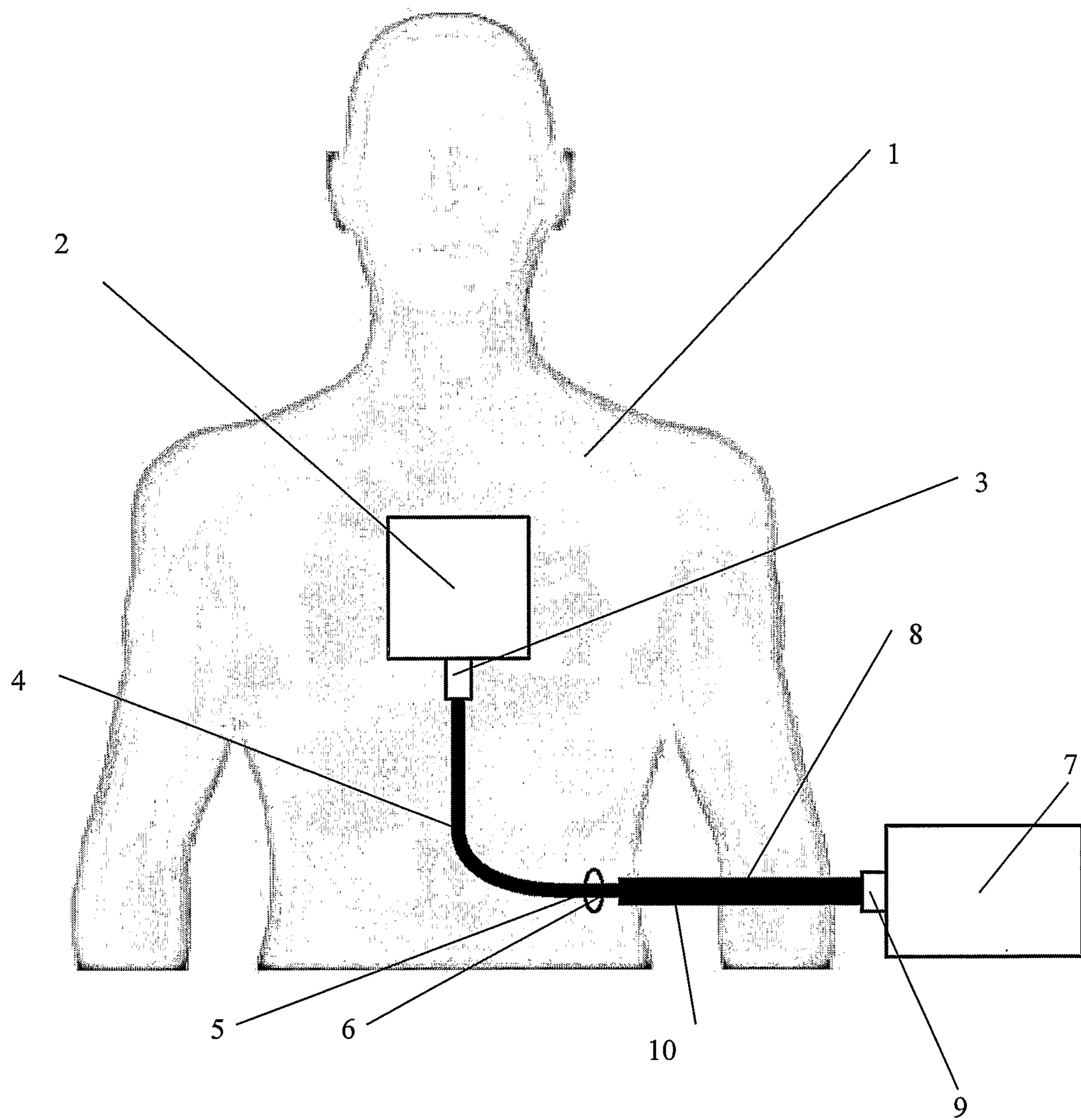

Figure 1

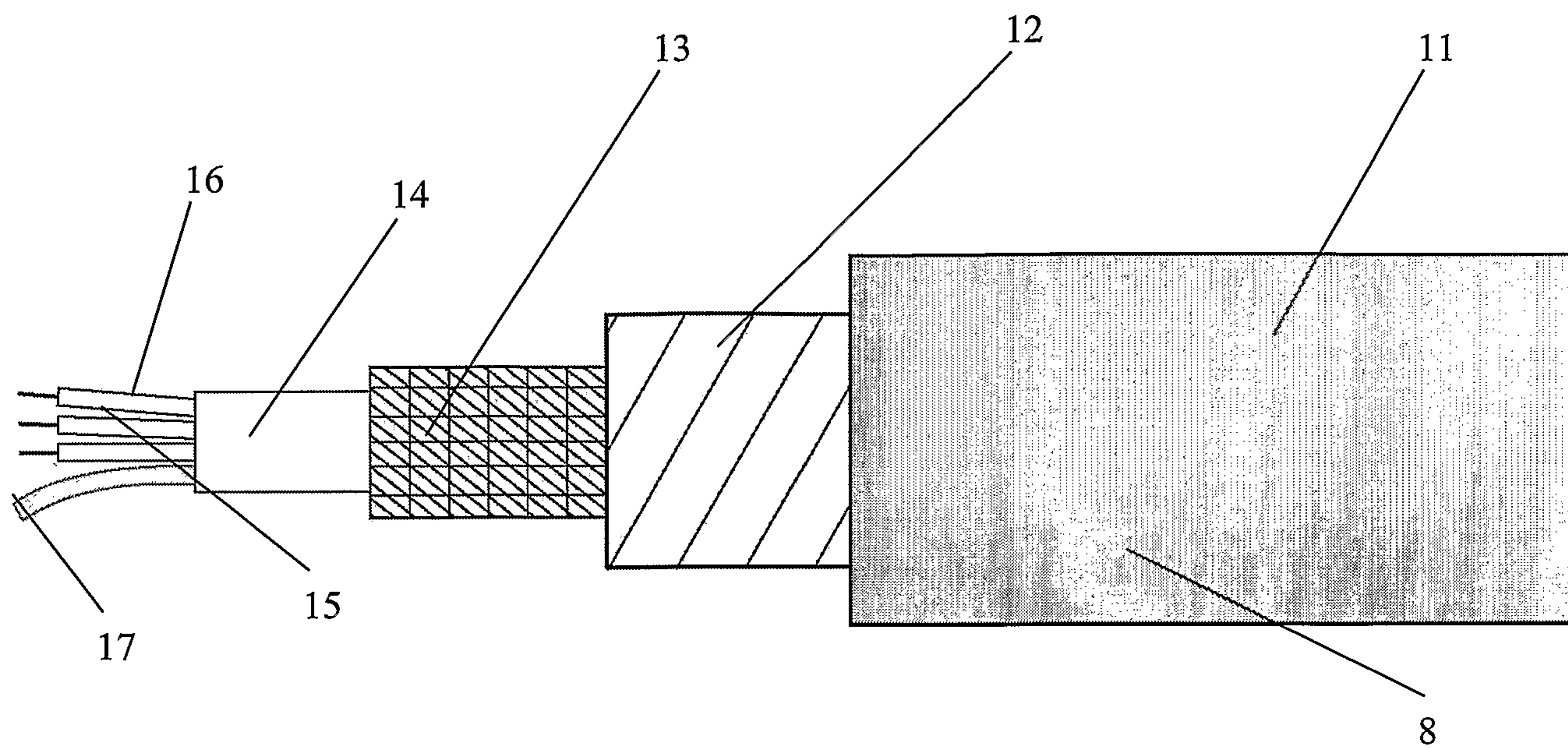

Figure 2

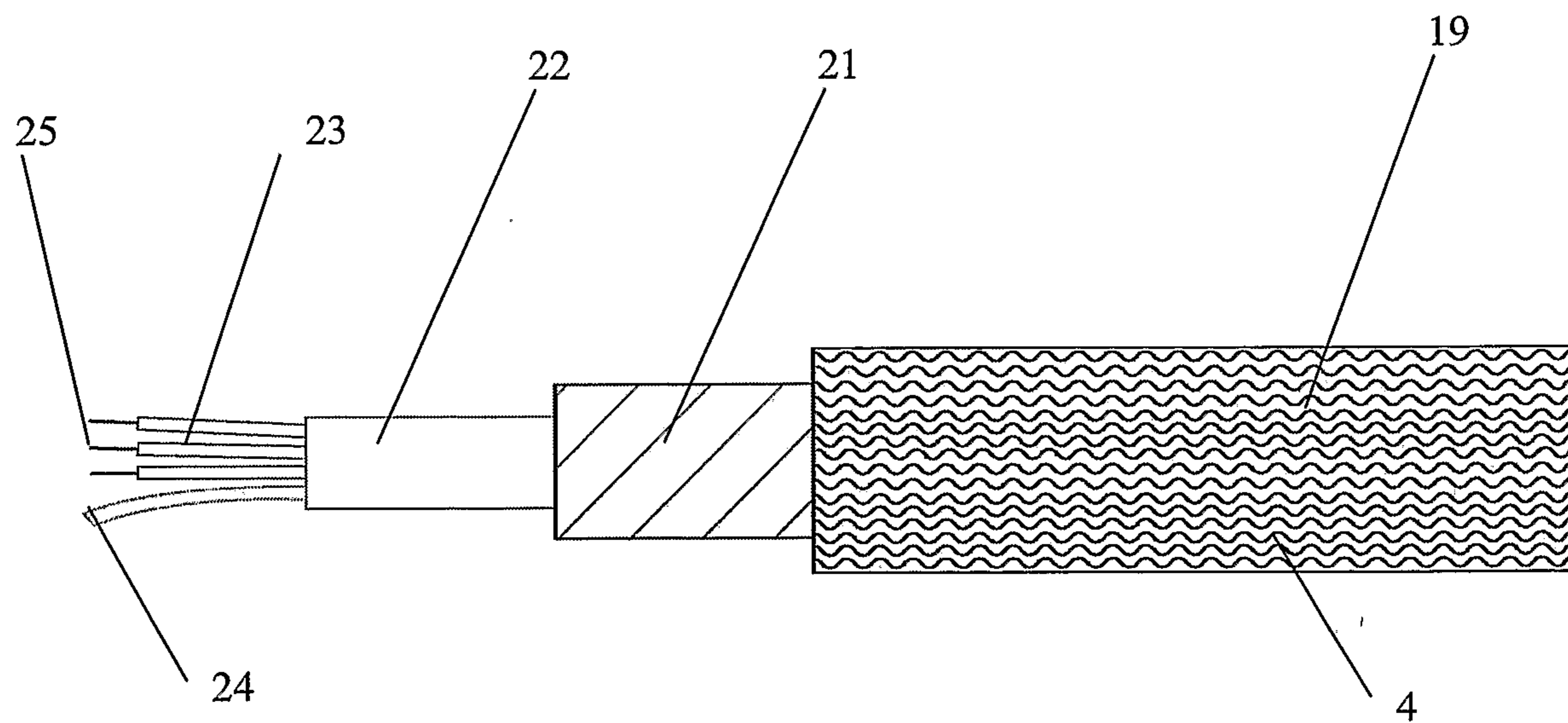

Figure 3

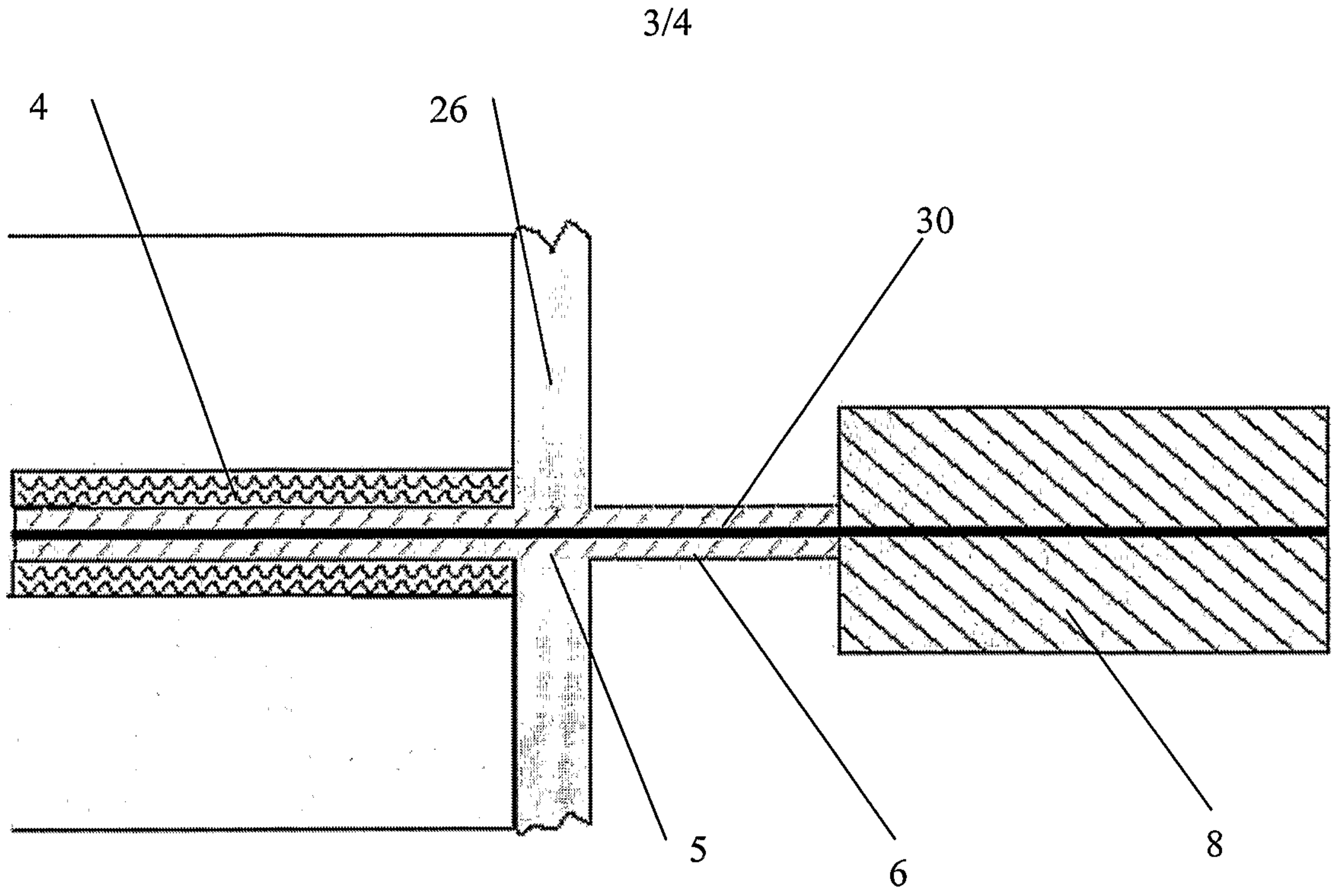

Figure 4

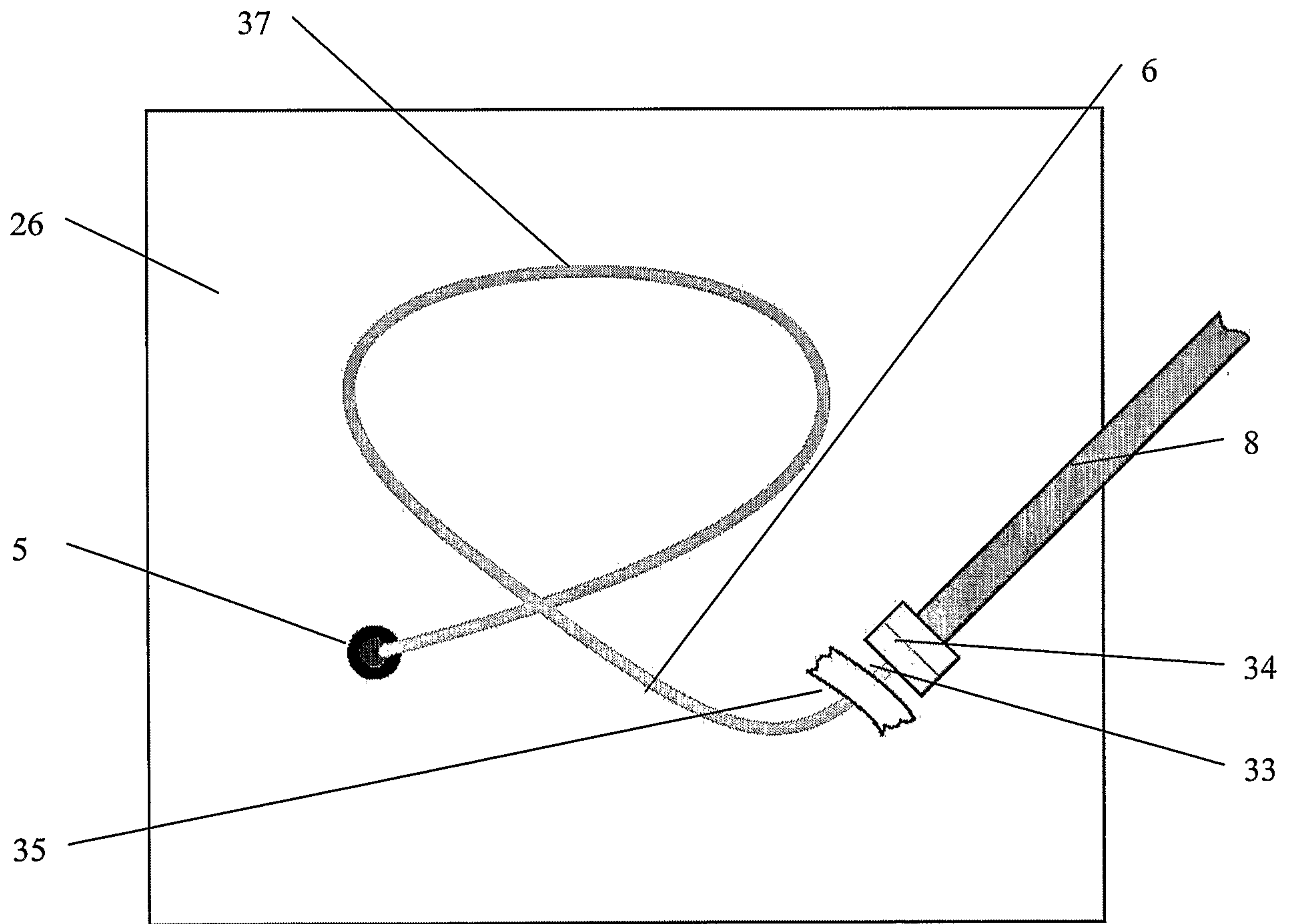

Figure 5

4/4

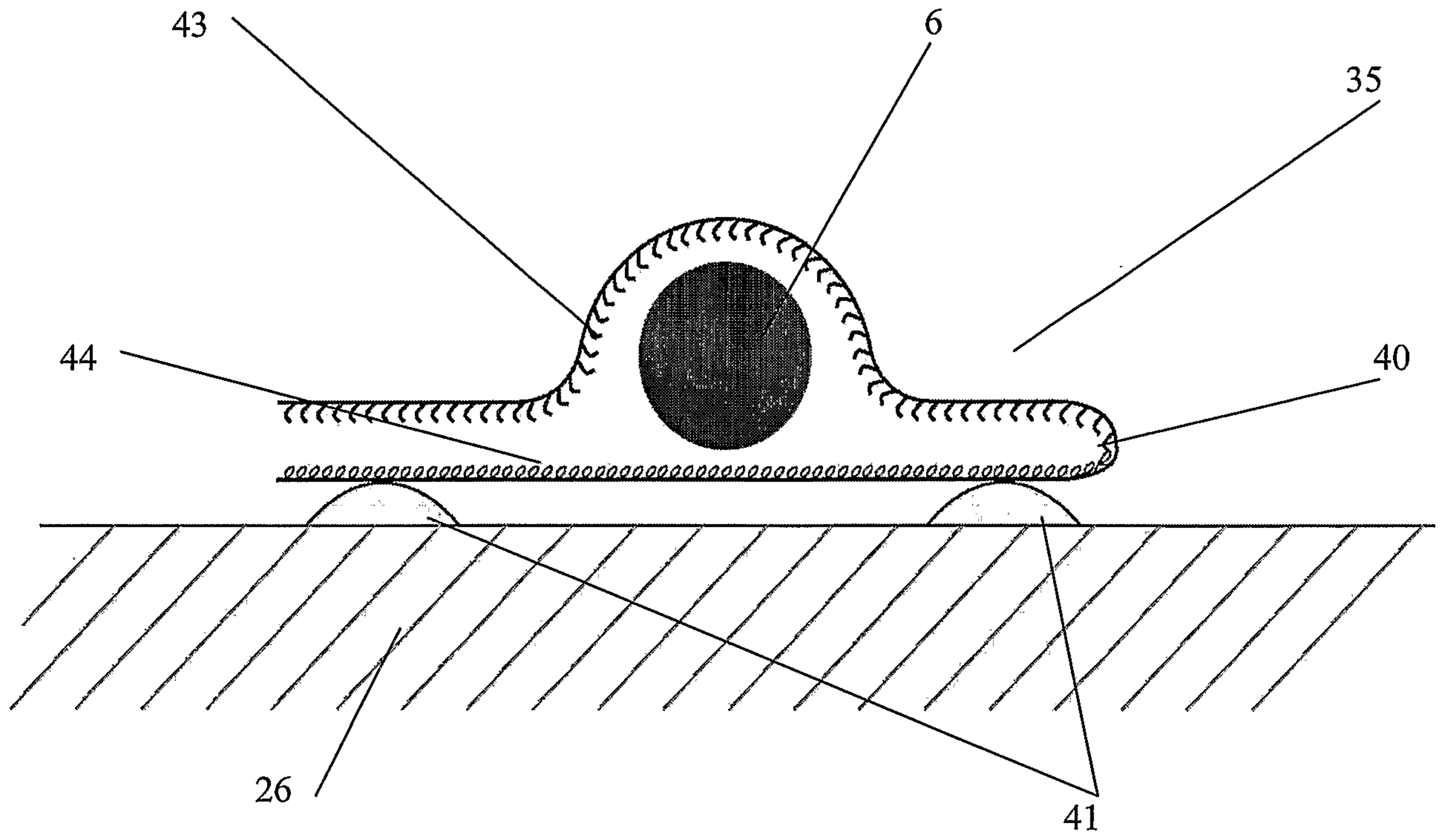

Figure 6

