

L. J. Parsons,
Tool Adjuster.

No. 82,335.

Patented Apr. 27, 1869.

Fig. 1.

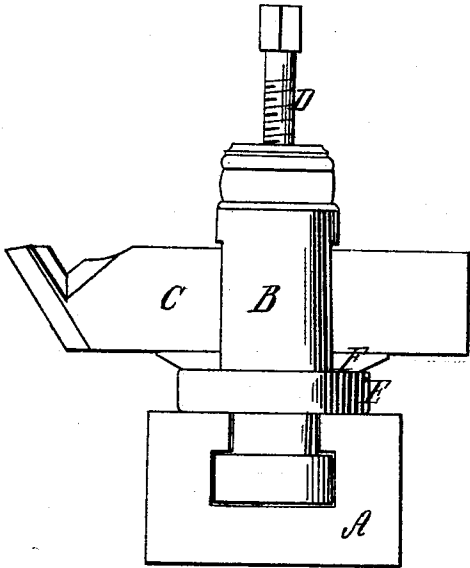

Fig. 2.

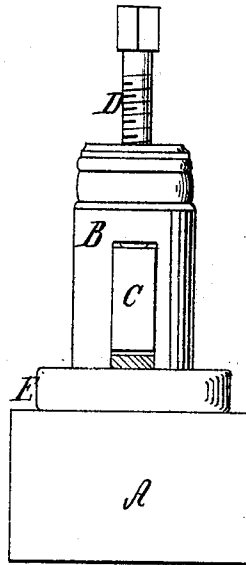

Fig. 3.

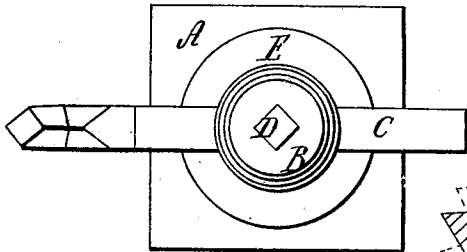
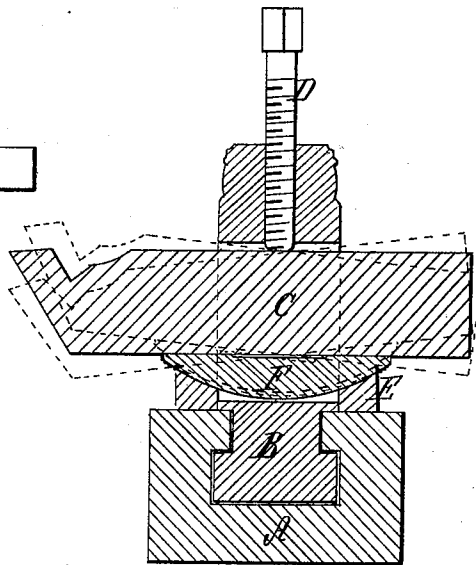

Fig. 4.



Witnesses;

John H. Shumway
a. j. Tibbits

Inventor;

L. J. PARSONS
By his Attorney

John E. Earl

United States Patent Office.

L. J. PARSONS, OF NEW HAVEN, CONNECTICUT, ASSIGNOR TO HIMSELF AND C. S. BUSHNELL, OF SAME PLACE.

Letters Patent No. 89,335, dated April 27, 1869.

IMPROVED TOOL-ADJUSTER FOR LATHES.

The Schedule referred to in these Letters Patent and making part of the same.

To all whom it may concern:

Be it known that I, L. J. PARSONS, of New Haven, in the county of New Haven, and State of Connecticut, have invented a new improvement in Tool-Adjuster for Lathes; and I do hereby declare the following, when taken in connection with the accompanying drawings, and the letters of reference marked thereon, to be a full, clear, and exact description of the same, and which said drawings constitute part of this specification, and represent in—

- Figure 1 a side view;
- Figure 2, a front view;
- Figure 3, a top view; and in
- Figure 4, a central section.

This invention relates to an improvement in the adjustment of the tool so as to raise or lower the point relatively to the surface being cut, and consists in the arrangement of a plate upon the rest, through which the tool-holder passes, and forming in the said plate a groove, corresponding to the opening through the tool-holder, which said groove is adapted to receive an adjusting-block, which is flat upon the upper surface, and the under surface the segment of a circle, the said block lying in the groove in the plate, and through an opening in the tool-holder, so that the under edge of the tool rests in the said block, while the screw through the upper end of the tool-holder bears upon the cutter, to bind it firmly in position, it being adjusted to different heights of the point by setting the block at different positions through the tool-holder, the said segmental surface inclining to raise or lower the point in proportion as it is placed further through the holder or drawn back.

To enable others to construct and use my improvement, I will fully describe the same, as illustrated in the accompanying drawings.

A is the rest of an ordinary lathe, to which the tool-holder B is attached, in the usual manner, the said tool-holder having an opening, through which to pass the tool C, the said tool being held in position by the screw D.

The usual manner of holding the tool is to place it directly upon the surface of the collar E, which surrounds the tool-holder, and lies upon the surface of the rest. By this construction, the point of the tool

must be formed to give the proper elevation, or it must be blocked up to raise the point.

To facilitate the adjusting of the tool to different elevations of the cutting-point, I place beneath the tool a block, F, which passes through the tool-holder, formed flat upon its upper surface, to receive the tool, and its under surface a segment of a circle, and I cut a groove in the plate E, to correspond to the segment, or under surface of the block F.

Therefore, to elevate the point of the tool, as in red, fig. 4, force the block F further into the groove in the collar E, which lowers the front end; and raises the inner end of the block F, and consequently inclines the bearing surface of the tool, so as to raise the point as denoted in red, or, to lower the point, reverse the operation, as denoted in blue, and when in position, turn hard down the screw, to bind the parts together, and securely hold the same in the desired position.

By this means the tool may be readily adjusted to any desired elevation of the cutting-point.

I serrate or roughen the under edge of the block F, as seen in fig. 2, in order to give a better hold of the block on its bearing.

I do not broadly claim as my invention the arrangement of a block beneath the tool-holder for the purpose of adjustment, as I am aware of the patent of A. Hathaway, March 8, 1864, but in that invention the block is of different form, the clamp or tool-holder passing through the block, whereas in my invention, the block is not of a spherical form, and passes through, and is retained in position by the tool-holder.

Having fully described my invention,

What I claim as new and useful, and desire to secure by Letters Patent, is—

The combination with the tool-post B, and slotted ring-collar E, of the segment of a flat circular plate or disk, located in the mortise, in the tool-post, and serrated on the lower and curved surface for better adhesion to the ring-collar, all constructed and combined in the manner described.

L. J. PARSONS.

Witnesses:

JOHN H. SHUMWAY,
A. J. TIBBITS.