



- (51) International Patent Classification: *B61F 5/26* (2006.01)
- (21) International Application Number: PCT/US2014/072350
- (22) International Filing Date: 24 December 2014 (24.12.2014)
- (25) Filing Language: English
- (26) Publication Language: English
- (30) Priority Data:

61/921,961	30 December 2013 (30.12.2013)	US
62/065,438	17 October 2014 (17.10.2014)	US
14/561,897	5 December 2014 (05.12.2014)	US
14/562,005	5 December 2014 (05.12.2014)	US
14/562,082	5 December 2014 (05.12.2014)	US
- (71) Applicant: NEVIS INDUSTRIES LLC [US/US]; 2711 Centerville Road, Suite 400, Wilmington, DE 19808 (US).
- (72) Inventors: GOTLUND, Erik, L.; 1150 Harwood Drive, Green Oaks, IL 60048 (US). JEAMBEY, Jon, R.; 2704 High Meadow Road, Naperville, IL 60564 (US). NIBOU-AR, F., Andrew; 405 N. Wabash, Chicago, IL 60611 (US). PIKE, James, A.; 3775 Bearcreek Road, Fairview, PA 16415 (US). BRYANT, Jason, C.; 1202 Morrison Drive, Erie, PA 16505 (US). STULL, Jonathan, A.; 2120 West 22nd Street, Erie, PA 16502 (US). KURTZHALS, William, A.; 4710 McClelland Avenue, Erie, PA 16510 (US). MANIBHARATHI, Roshan, N.; 320 Beau Drive #5, Des Plaines, IL 60016 (US).
- (74) Agent: KEENAN, Kevin, C.; Banner & Witcoff, Ltd., 10 South Wacker Drive, Suite 3000, Chicago, IL 60606-7407 (US).
- (81) Designated States (*unless otherwise indicated, for every kind of national protection available*): AE, AG, AL, AM, AO, AT, AU, AZ, BA, BB, BG, BH, BN, BR, BW, BY, BZ, CA, CH, CL, CN, CO, CR, CU, CZ, DE, DK, DM, DO, DZ, EC, EE, EG, ES, FI, GB, GD, GE, GH, GM, GT,

[Continued on next page]

(54) Title: RAILCAR TRUCK ROLLER BEARING ADAPTER-PAD SYSTEMS

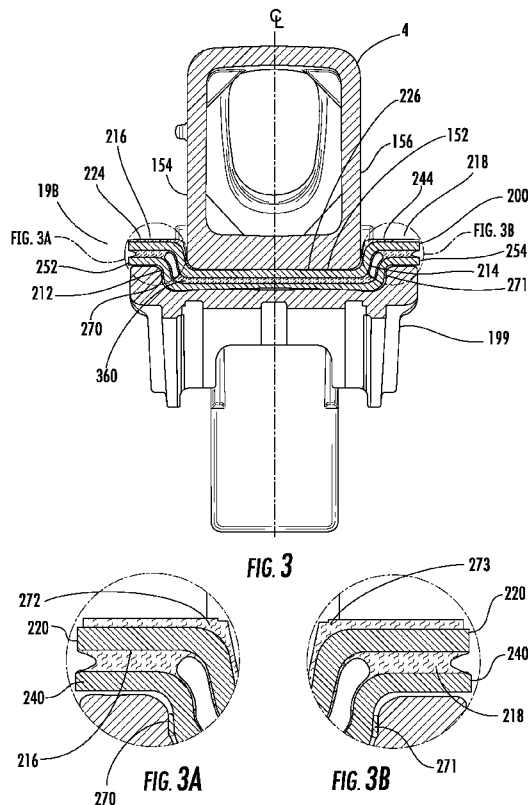

(57) Abstract: A railcar truck and adapter pad system for placement between a roller bearing and side frame pedestal roof of a three-piece railcar truck. Many different features of the pad and/or the adapter-pad interface are configured to improve stiffness characteristics to satisfy both curving and high speed performance of the railcar truck.

WO 2015/103075 A2



HN, HR, HU, ID, IL, IN, IR, IS, JP, KE, KG, KN, KP, KR, KZ, LA, LC, LK, LR, LS, LU, LY, MA, MD, ME, MG, MK, MN, MW, MX, MY, MZ, NA, NG, NI, NO, NZ, OM, PA, PE, PG, PH, PL, PT, QA, RO, RS, RU, RW, SA, SC, SD, SE, SG, SK, SL, SM, ST, SV, SY, TH, TJ, TM, TN, TR, TT, TZ, UA, UG, US, UZ, VC, VN, ZA, ZM, ZW.

TZ, UG, ZM, ZW), Eurasian (AM, AZ, BY, KG, KZ, RU, TJ, TM), European (AL, AT, BE, BG, CH, CY, CZ, DE, DK, EE, ES, FI, FR, GB, GR, HR, HU, IE, IS, IT, LT, LU, LV, MC, MK, MT, NL, NO, PL, PT, RO, RS, SE, SI, SK, SM, TR), OAPI (BF, BJ, CF, CG, CI, CM, GA, GN, GQ, GW, KM, ML, MR, NE, SN, TD, TG).

(84) Designated States (unless otherwise indicated, for every kind of regional protection available): ARIPO (BW, GH, GM, KE, LR, LS, MW, MZ, NA, RW, SD, SL, ST, SZ,

Published:

— without international search report and to be republished upon receipt of that report (Rule 48.2(g))

RAILCAR TRUCK ROLLER BEARING ADAPTER-PAD SYSTEMS

CROSS-REFERENCE TO RELATED APPLICATIONS

[0001] This international application claims priority to U.S. Provisional Patent Application No. 61/921,961, filed December 30, 2013, entitled "Railcar Truck Roller Bearing Adapter-Pad Systems", and U.S. Provisional Patent Application No. 62/065,438, filed October 17, 2014, entitled "Railcar Truck Roller Bearing Adapter-Pad Systems", all of which are incorporated by reference. This international application also claims priority to U.S. Application No. 14/561,897 filed December 5, 2014 entitled "Railcar Truck Roller Bearing Adapter Pad Systems", U.S. Application No. 14/562,005 filed December 5, 2014 entitled "Railcar Truck Roller Bearing Adapter Pad Systems", and U.S. Application No. 14/562,082 filed December 5, 2014 entitled "Railcar Truck Roller Bearing Adapter Pad Systems" all of which are incorporated by reference.

TECHNICAL FIELD

[0002] The present disclosure relates to railcar trucks, and more particularly to roller bearing adapter and adapter-pad systems that can improve stiffness, damping, and displacement characteristics to satisfy both curving and high speed performance of a three-piece railcar truck.

BACKGROUND

[0003] The conventional railway freight car truck in use in North America for many decades has been the three-piece truck, comprising a pair of parallel side frames connected by a transversely mounted bolster. The bolster is supported on the side frames by spring groups consisting of a number of individual coil springs. The wheelsets of the truck are received in bearing adapters placed in leading and trailing pedestal jaws in the side frames, so that axles of the wheelsets are parallel in a transverse or lateral position relative to the two rails. The railway car is mounted on the center plate of the bolster, which allows the truck to rotate with respect to the car. The spring groups and side frame to bolster clearance stops permit the side frames to move somewhat with respect to the bolster, about the longitudinal, vertical and transverse or lateral axes.

[0004] It has long been desired to improve the performance of the three-piece truck. Resistance to lateral and longitudinal loads and truck performance can be characterized in terms of one or more of the following well-known phenomena.

[0005] “Parallelogramming” occurs when one side frame moves forward longitudinally with respect to the other, such that the leading and trailing wheel sets remain parallel to each other but they are not perpendicular to the rails, as may happen when a railway car truck encounters a curve. This action of parallelogramming side frames is also referred to as truck warp.

[0006] “Hunting” describes an oscillating sinusoidal longitudinal and lateral movement of the wheelsets that causes the railcar body to move side-to-side. This sinusoidal movement is the harmonic oscillation caused by the tapered profile of the wheelset. While the tapered profile promotes natural oscillation of the wheelset, it is also the primary feature that allows the wheelsets to develop a rolling radius difference and negotiate curves. Hunting may be dangerous when the oscillations attain a resonant frequency. Hunting is more likely to occur when there is a lack of proper alignment in the truck as manufactured, or developed over time through various operating conditions such as wear of the truck components. Hunting is also more likely to occur when the railcar is operated at higher speeds. The speed at which hunting is observed to occur is referred to as the “hunting threshold.”

[0007] Several approaches have been tried to improve the stability of the standard three-piece truck to prevent parallelogramming and hunting, while at the same time ensuring that the truck is able to develop the appropriate geometry to accommodate the different distances traveled by the wheels on the inside and outside of a turn, respectively. Additional improvement is desired, both to meet truck hunting requirements as well as to simultaneously improve stiffness, damping, and displacement characteristics that yield good high speed and curving performance.

BRIEF SUMMARY OF THE INVENTION

[0008] This Summary provides an introduction to some general concepts relating to this invention in a simplified form that are further described below in the Detailed Description.

[0009] Aspects of the disclosure herein relate to railcar trucks. In one example, the disclosure provides a railcar truck including a three-piece truck comprising a bolster, a first side frame having a first pedestal of AAR standard geometry and a second pedestal of AAR standard geometry, and a second side frame having a third pedestal of AAR standard geometry and a fourth pedestal of AAR standard geometry, each side frame pedestal defining a first outer side and a second outer side and having a pedestal roof located and extending between the first outer side and the second outer side. The railcar truck can include a first wheelset engaged with a first roller bearing and engaged with a second roller bearing; a second wheelset engaged with a third roller bearing and engaged with a fourth roller bearing; a first roller bearing adapter having AAR standard thrust lug clearances engaged with the first roller bearing, a second roller bearing adapter having AAR standard thrust lug clearances engaged with the second roller bearing, a third roller bearing adapter having AAR standard thrust lug clearances engaged with the third roller bearing, and a fourth roller bearing adapter having AAR standard thrust lug clearances engaged with the fourth roller bearing each roller bearing, each roller bearing adapter symmetrical about a lateral centerline and symmetrical about a longitudinal centerline, and defining a bottom surface and a crowned top surface, the top surface defining opposing first and second vertical shoulders that project upwardly from the top surface on either side of the side frame. The railcar truck can also include a first adapter pad engaged with the first pedestal roof and the first roller bearing adapter, a second adapter pad engaged with the second pedestal roof and the second roller bearing adapter, a third adapter pad engaged with the third pedestal roof and the third roller bearing adapter, a fourth adapter pad engaged with the fourth pedestal roof and the fourth roller bearing adapter, and each adapter pad includes a continuous top plate having a central portion, first and second upturned regions projecting upwardly from opposite edges of the central portion, a first lateral flange projecting outwardly from the first upturned region, and a second lateral flange projecting outwardly from the second upturned region; a continuous bottom plate having a central portion, first and second upturned regions projecting upwardly from opposite edges of the central portion, a first lateral flange projecting outwardly from the first upturned region, and a second lateral flange projecting outwardly from the

second upturned region; a first outer elastomeric member disposed between the first lateral flanges of the top and bottom plates, defining a first outer edge, and having a static thickness within the range of 0.15 inches to 0.30 inches; a second outer elastomeric member disposed between the second lateral flanges of the top and bottom plates, defining a second outer edge, and having a static thickness within the range of 0.15 inches to 0.30 inches; a central elastomeric member disposed between the central portion of the top and bottom plates, defining a third outer edge, having a substantially uniform thickness, and having a static thickness within the range of 0.15 inches to 0.25 inches; a first substantially hollow portion disposed between the top plate and the bottom plate and between the central elastomeric member and the first outer elastomeric member; a second substantially hollow portion disposed between the top plate and the bottom plate and between the central elastomeric member and the second outer elastomeric member; a first lateral adapter grip disposed between an inside surface of the first vertical shoulder of the engaged roller bearing adapter and the first upturned region of the bottom plate; a second lateral adapter grip disposed between an inside surface of the second vertical shoulder of the engaged roller bearing adapter and the second upturned region of the bottom plate; a first lateral side frame grip disposed between an outer surface of the first upturned region of the top plate and the first outer side of the engaged side frame pedestal; a second lateral side frame grip disposed between an outer surface of the second upturned region of the top plate and the second outer side of the engaged side frame pedestal. The top plate and bottom plate central portions and the central elastomeric member of each adapter pad can be disposed at least in part beneath the engaged pedestal roof, and the first and second laterally projecting flanges of the top plate and the bottom plate and the first and second outer elastomeric members of each adapter pad can be entirely disposed above the vertical shoulders of the engaged roller bearing adapter and outside of the engaged pedestal roof; and the combined top plate, bottom plate, and elastomeric members of each of the adapter pads can provide a longitudinal stiffness of at least 45,000 pounds per inch through a longitudinal displacement of the top plate relative to the bottom plate of up to 0.139 inches from a central position, a lateral stiffness of at least 45,000 pounds per inch through a lateral displacement of the top plate relative

to the bottom plate of up to 0.234 inches from the central position, and a rotational stiffness of at least 250,000 pound *inches per radian of rotation through a rotational displacement of the top plate relative to the bottom plate of up to 41 milliradians from the central position when a vertical load of 35,000 pounds is applied to the central portions of the adapter pad.

[0010] In another example the disclosure provides railcar truck including a three-piece truck with a bolster and at least one side frame having at least one side frame pedestal defining a first outer side and a second outer side, and a pedestal roof located and extending between the first outer side and the second outer side. The railcar truck can include at least one wheelset positioned transversely with the at least one side frame; at least one roller bearing engaged with the at least one wheelset; at least one roller bearing adapter, defining a bottom surface and a top surface, the bottom surface engaged with the roller bearing, the top surface defining opposing first and second vertical shoulders that project upwardly from the top surface, on either side of the at least one side frame; at least one adapter pad configured to engage with the at least one roller bearing adapter and the pedestal roof, the at least one adapter pad including a top plate having a central portion, first and second upturned regions projecting upwardly from opposite edges of the central portion, a first lateral flange projecting outwardly from the first upturned region, and a second lateral flange projecting outwardly from the second upturned region; a bottom plate having a central portion, first and second upturned regions projecting upwardly from opposite edges of the central portion, a first lateral flange projecting outwardly from the first upturned region, and a second lateral flange projecting outwardly from the second upturned region; a first outer elastomeric member disposed between the first lateral flanges of the top and bottom plates; a second outer elastomeric member disposed between the second lateral flanges of the top and bottom plates; a central elastomeric member disposed between the central portion of the top and bottom plates; a first substantially hollow portion disposed between the top plate and the bottom plate and between the central elastomeric member and the first outer elastomeric member; a second substantially hollow portion disposed between the top plate and the bottom plate and between the central elastomeric member and the second outer elastomeric member. The top plate and bottom plate central portions

and the central elastomeric member can be disposed at least in part beneath the pedestal roof, and the first and second laterally projecting flanges of the top plate and the bottom plate and the first and second outer elastomeric members can be disposed above the vertical shoulders of the roller bearing adapter and entirely outside of the pedestal roof; and the top plate of the at least one adapter pad can be engaged with the at least one side frame such that movement between the top plate and the at least one side frame is restricted, and wherein the bottom plate of the adapter pad is engaged with the roller bearing adapter such that movement between the bottom plate and the roller bearing adapter is restricted.

[0011] In another example, the disclosure provides a railcar truck including a three-piece truck with a bolster; and a side frame having a side frame pedestal defining a first outer side and a second outer side, and a pedestal roof located and extending between the first outer side and the second outer side. The railcar truck can also include a wheelset; a roller bearing engaged with the wheelset; a roller bearing adapter, defining a bottom surface and a top surface, the bottom surface engaged with the roller bearing, the top surface defining opposing first and second vertical shoulders that project upwardly from the top surface on either side of the side frame; and an adapter pad configured to engage with the roller bearing adapter and the pedestal roof. The adapter pad can include a top plate having a central portion, first and second upturned regions projecting upwardly from opposite edges of the central portion, a first lateral flange projecting outwardly from the first upturned region, and a second lateral flange projecting outwardly from the second upturned region; a bottom plate having a central portion, first and second upturned regions projecting upwardly from opposite edges of the central portion, a first lateral flange projecting outwardly from the first upturned region, and a second lateral flange projecting outwardly from the second upturned region; a first outer elastomeric member disposed between the first lateral flanges of the top and bottom plates; a second outer elastomeric member disposed between the second lateral flanges of the top and bottom plates; a central elastomeric member disposed between the central portion of the top and bottom plates. The top plate and bottom plate central portions and the central elastomeric member can be disposed at least in part beneath the pedestal roof, and the first and second laterally projecting flanges of the

top plate and the bottom plate and the first and second outer elastomeric members can be disposed above the vertical shoulders of the roller bearing adapter and entirely outside of the pedestal roof; the top plate of the adapter pad can be fixedly engaged with the side frame such that movement between the top plate and the side frame is restricted, and wherein the bottom plate of the adapter pad is fixedly engaged with the roller bearing such that movement between the bottom plate and the roller bearing is restricted; and the combined surface area of the first and second outer elastomeric members at cross-sectional planes through the first and second outer elastomeric members in planes centered between the inner surfaces of the top and bottom plates can be at least 10 percent of the surface area of the central elastomeric member at a cross-section plane through the center of the central elastomeric member in a centered between the inner surfaces of the top and bottom plates.

[0012] Aspects of the disclosure herein also relate to adapter pads and adapter pad system. In one example, the disclosure provides a roller bearing adapter pad system configured for use with a three-piece truck having AAR standard geometry including a roller bearing adapter configured to engage a roller bearing. The roller bearing adapter can include a crowned top surface; a bottom surface configured to engage a roller bearing; first and second vertical shoulders that project upwardly from opposite lateral edges of the top surface, each vertical shoulder having a width of at least 0.5 inches; first and second longitudinal stops that project upwardly from opposite longitudinal edges of the top surface. The roller bearing adapter can be symmetrical about a lateral centerline and symmetrical about a longitudinal centerline; the thickness of the roller bearing adapter measured between the crowned top surface and the bottom surface can be less than 0.75 inches as measured at the longitudinal centerline; the roller bearing adapter can have cross-sectional moment of inertia of a cross-section at the longitudinal centerline of the roller bearing adapter around a lateral axis about 5.2 inches above a center axis of an axle that is in the range of about 1.0 in⁴ to about 2.0 in⁴; and the roller bearing adapter can have a cross-sectional moment of inertia of a cross-section at the longitudinal centerline of the roller bearing adapter around a vertical axis at the center of the adapter that is in the range of about 50 in⁴ to about 100 in⁴. The roller

bearing adapter system also can include an adapter pad engaged with the roller bearing adapter and configured to engage a side frame pedestal roof, the adapter pad including a continuous top plate having a central portion, first and second upturned regions projecting upwardly from opposite edges of the central portion, a first lateral flange projecting outwardly from the first upturned region, and a second lateral flange projecting outwardly from the second upturned region; a continuous bottom plate having a central portion, first and second upturned regions projecting upwardly from opposite edges of the central portion, a first lateral flange projecting outwardly from the first upturned region, and a second lateral flange projecting outwardly from the second upturned region; a first outer elastomeric member disposed between the first lateral flanges of the top and bottom plates, having a substantially uniform static thickness within the range of 0.15 inches to 0.30 inches; a second outer elastomeric member disposed between the second lateral flanges of the top and bottom plates, having a static thickness within the range of 0.15 inches to 0.30 inches; a central elastomeric member disposed between the central portion of the top and bottom plates, having a static thickness within the range of 0.15 inches to 0.25 inches; a first substantially hollow portion disposed between the top plate and the bottom plate and between the central elastomeric member and the first outer elastomeric member; a second substantially hollow portion disposed between the top plate and the bottom plate and between the central elastomeric member and the second outer elastomeric member; a first lateral adapter grip disposed between an inside surface of the first vertical shoulder of the engaged roller bearing adapter and the first upturned region of the bottom plate; a second lateral adapter grip disposed between an inside surface of the second vertical shoulder of the engaged roller bearing adapter and the second upturned region of the bottom plate; a first lateral side frame grip disposed on an outer surface of the first upturned region of the top plate; a second lateral side frame grip disposed between an outer surface of the second upturned region of the top plate. The first and second laterally projecting flanges of the top plate and the bottom plate and the first and second outer elastomeric members of each adapter pad can be entirely disposed above the vertical shoulders of the roller bearing adapter.

[0013] In another example, the disclosure provides a roller bearing adapter pad system configured for use with a three-piece truck having AAR standard geometry including a roller bearing adapter configured to engage a roller bearing. The bearing adapter can include a top surface; a bottom surface configured to engage a roller bearing; first and second vertical shoulders that project upwardly from opposite lateral edges of the top surface, each vertical shoulder having a width of at least 0.5 inches and a height in the range of 0.75 inches to 1.5 inches. The roller bearing adapter system can include an adapter pad engaged with the roller bearing adapter and configured to engage a side frame pedestal roof, the adapter pad including a continuous top plate having a central portion, first and second upturned regions projecting upwardly from opposite edges of the central portion, a first lateral flange projecting outwardly from the first upturned region, and a second lateral flange projecting outwardly from the second upturned region; a continuous bottom plate having a central portion, first and second upturned regions projecting upwardly from opposite edges of the central portion, a first lateral flange projecting outwardly from the first upturned region, and a second lateral flange projecting outwardly from the second upturned region; a first outer elastomeric member disposed between the first lateral flanges of the top and bottom plates, defining a first outer edge; a second outer elastomeric member disposed between the second lateral flanges of the top and bottom plates, defining a second outer edge; a central elastomeric member disposed between the central portion of the top and bottom plates, defining a third outer edge; a first substantially hollow portion disposed between the top plate and the bottom plate and between the central elastomeric member and the first outer elastomeric member; a second substantially hollow portion disposed between the top plate and the bottom plate and between the central elastomeric member and the second outer elastomeric member. The first and second laterally projecting flanges of the top plate and the bottom plate and the first and second outer elastomeric members of each adapter pad can be entirely disposed above the vertical shoulders of the roller bearing adapter; the combined surface area of the first and second outer elastomeric members at cross-sectional planes through the first and second outer elastomeric members in planes centered between the inner surfaces of the top and bottom plates can be at least 10 percent of the surface area of the central

elastomeric member at a cross-section plane through the center of the central elastomeric member in a centered between the inner surfaces of the top and bottom plates; and the combined top plate, bottom plate, and elastomeric members provide a longitudinal stiffness of at least 45,000 pounds per inch through a longitudinal displacement of the top plate relative to the bottom plate of up to 0.139 inches from a central position, a lateral stiffness of at least 45,000 pounds per inch through a lateral displacement of the top plate relative to the bottom plate of up to 0.234 inches from the central position, and a rotational stiffness of at least 250,000 pound *inches per radian of rotation through a rotational displacement of the top plate relative to the bottom plate of up to 41 milliradians from the central position when a vertical load of 35,000 pounds is applied to the central portions of the adapter pad.

[0014] In another example, the disclosure provides a roller bearing adapter pad configured for use with a three-piece truck including a continuous top plate having a central portion, first and second upturned regions projecting upwardly from opposite edges of the central portion, a first lateral flange projecting outwardly from the first upturned region, and a second lateral flange projecting outwardly from the second upturned region; a continuous bottom plate having a central portion, first and second upturned regions projecting upwardly from opposite edges of the central portion, a first lateral flange projecting outwardly from the first upturned region, and a second lateral flange projecting outwardly from the second upturned region; a first outer elastomeric member disposed between the first lateral flanges of the top and bottom plates; a second outer elastomeric member disposed between the second lateral flanges of the top and bottom plates; a central elastomeric member disposed between the central portion of the top and bottom plates; a first substantially hollow portion disposed between the top plate and the bottom plate and between the central elastomeric member and the first outer elastomeric member; a second substantially hollow portion disposed between the top plate and the bottom plate and between the central elastomeric member and the second outer elastomeric member. The combined top plate, bottom plate, and elastomeric members of the adapter pad can provide a longitudinal stiffness of at least 45,000 pounds per inch through a longitudinal displacement of the top plate relative to the bottom plate of up to 0.139 inches from a central position, a lateral stiffness of at least 45,000 pounds per inch

through a lateral displacement of the top plate relative to the bottom plate of up to 0.234 inches from the central position, and a rotational stiffness of at least 250,000 pound *inches per radian of rotation through a rotational displacement of the top plate relative to the bottom plate of up to 41 milliradians from the central position when a vertical load of 35,000 pounds is applied to the central portions of the adapter pad.

[0015] In another example, the disclosure provides a roller bearing adapter pad system configured for use with a three-piece truck having AAR standard geometry. The roller bearing adapter pad system can a roller bearing adapter configured to engage a roller bearing, wherein the roller bearing adapter includes a crowned top surface; a bottom surface configured to engage a roller bearing; wherein the roller bearing adapter has cross-sectional moment of inertia of a cross-section at the longitudinal centerline of the roller bearing adapter around a lateral axis about 5.2 inches above a center axis of an axle that is in the range of about 1.0 in⁴ to about 2.0 in⁴; and wherein the roller bearing adapter has a cross-sectional moment of inertia of a cross-section at the longitudinal centerline of the roller bearing adapter around a vertical axis at the center of the adapter that is in the range of about 50 in⁴ to about 100 in⁴. The roller bearing adapter pad system can also include an adapter pad engaged with the roller bearing adapter and configured to engage a side frame pedestal roof, wherein the adapter pad includes a continuous top plate; a continuous bottom plate; an elastomeric member disposed between the top and bottom plates, having a static thickness within the range of 0.15 inches to 0.30 inches; and wherein the surface area of the elastomeric member at a cross-sectional plane centered between the inner surfaces of the top and bottom plates is greater than about 50 square inches. The combined top plate, bottom plate, and elastomeric members of the roller bearing adapter pad system can provide a longitudinal stiffness of at least 45,000 pounds per inch through a longitudinal displacement of the top plate relative to the bottom plate of up to 0.139 inches from a central position, a lateral stiffness of at least 45,000 pounds per inch through a lateral displacement of the top plate relative to the bottom plate of up to 0.234 inches from the central position, and a rotational stiffness of at least 250,000 pound *inches per radian of rotation through a rotational displacement of the top plate relative to the bottom plate of up to 41

milliradians from the central position when a vertical load of 35,000 pounds is applied to the central portion of the adapter pad.

[0016] Aspects of the disclosure herein also relate to methods for forming railcar trucks, adapter pad systems, and adapter pads. In one example, the disclosure provides a method for forming a railcar truck including providing a three-piece truck. The method can include providing a three-piece truck including a bolster; and a first side frame having a first pedestal of AAR standard geometry and a second pedestal of AAR standard geometry, and a second side frame having a third pedestal of AAR standard geometry and a fourth pedestal of AAR standard geometry, each side frame pedestal defining a first outer side and a second outer side and having a pedestal roof located and extending between the first outer side and the second outer side. The method further can include providing a first wheelset engaged with a first roller bearing and engaged with a second roller bearing; providing a second wheelset engaged with a third roller bearing and engaged with a fourth roller bearing; providing a first roller bearing adapter having AAR standard thrust lug clearances engaged with the first roller bearing, a second roller bearing adapter having AAR standard thrust lug clearances engaged with the second roller bearing, a third roller bearing adapter having AAR standard thrust lug clearances engaged with the third roller bearing, and a fourth roller bearing adapter having AAR standard thrust lug clearances engaged with the fourth roller bearing each roller bearing, each roller bearing adapter symmetrical about a lateral centerline and symmetrical about a longitudinal centerline, and defining a bottom surface and a crowned top surface, the top surface defining opposing first and second vertical shoulders that project upwardly from the top surface on either side of the side frame. The method further can include providing a first adapter pad, a second adapter pad, a third adapter pad, a fourth adapter pad, each adapter pad including a continuous top plate having a central portion, first and second upturned regions projecting upwardly from opposite edges of the central portion, a first lateral flange projecting outwardly from the first upturned region, and a second lateral flange projecting outwardly from the second upturned region; a continuous bottom plate having a central portion, first and second upturned regions projecting upwardly from opposite edges of the central portion, a first lateral flange projecting outwardly from the first upturned region, and a second

lateral flange projecting outwardly from the second upturned region; a first outer elastomeric member disposed between the first lateral flanges of the top and bottom plates, defining a first outer edge, and having a static thickness within the range of 0.15 inches to 0.30 inches; a second outer elastomeric member disposed between the second lateral flanges of the top and bottom plates, defining a second outer edge, and having a static thickness within the range of 0.15 inches to 0.30 inches; a central elastomeric member disposed between the central portion of the top and bottom plates, defining a third outer edge, and having a static thickness within the range of 0.15 inches to 0.25 inches; a first substantially hollow portion disposed between the top plate and the bottom plate and between the central elastomeric member and the first outer elastomeric member; a second substantially hollow portion disposed between the top plate and the bottom plate and between the central elastomeric member and the second outer elastomeric member; a first elastomeric lateral adapter grip disposed between an inside surface of the first vertical shoulder of the engaged roller bearing adapter and the first upturned region of the bottom plate; a second elastomeric lateral adapter grip disposed between an inside surface of the second vertical shoulder of the engaged roller bearing adapter and the second upturned region of the bottom plate; a first elastomeric lateral side frame grip disposed between an outer surface of the first upturned region of the top plate and the first outer side of the engaged side frame pedestal; a second elastomeric lateral side frame grip disposed between an outer surface of the second upturned region of the top plate and the second outer side of the engaged side frame pedestal. The method further can include engaging the first adapter pad with the first pedestal roof and the first roller bearing adapter such that movement of the top plate of the first adapter pad relative to the pedestal roof is restricted and that movement between the bottom plate of the first adapter pad relative to the first roller bearing adapter is restricted; engaging the second adapter pad with the second pedestal roof and the second roller bearing adapter such that movement of the top plate of the second adapter pad relative to the pedestal roof is restricted and that movement between the bottom plate of the second adapter pad relative to the second roller bearing adapter is restricted; engaging the third adapter pad with the third pedestal roof and the third roller bearing adapter such that movement of the top plate of the third

adapter pad relative to the pedestal roof is restricted and that movement between the bottom plate of the third adapter pad relative to the third roller bearing adapter is restricted; engaging the fourth adapter pad with the fourth pedestal roof and the fourth roller bearing adapter such that movement of the top plate of the fourth adapter pad relative to the pedestal roof is restricted and that movement between the bottom plate of the fourth adapter pad relative to the fourth roller bearing adapter is restricted. The top plate and bottom plate central portions and the central elastomeric member of each adapter pad can be disposed at least in part beneath the engaged pedestal roof, and the first and second laterally projecting flanges of the top plate and the bottom plate and the first and second outer elastomeric members of each adapter pad can be entirely disposed above the vertical shoulders of the engaged roller bearing adapter and outside of the engaged pedestal roof.

[0017] In another example, the disclosure provides a method of forming an adapter pad system configured for use with three-piece truck having AAR standard geometry including providing a roller bearing adapter with AAR standard thrust lug clearances engaged with the first roller bearing, the roller bearing adapter symmetrical about a lateral centerline and symmetrical about a longitudinal centerline, and defining a bottom surface and a crowned top surface, the top surface defining opposing first and second vertical shoulders that project upwardly from the top surface, and providing an adapter pad configured to engage a pedestal roof and the roller bearing adapter the adapter pad including providing a continuous top plate having a central portion, first and second upturned regions projecting upwardly from opposite edges of the central portion, a first lateral flange projecting outwardly from the first upturned region, and a second lateral flange projecting outwardly from the second upturned region; providing a continuous bottom plate having a central portion, first and second upturned regions projecting upwardly from opposite edges of the central portion, a first lateral flange projecting outwardly from the first upturned region, and a second lateral flange projecting outwardly from the second upturned region; providing a first outer elastomeric member disposed between the first lateral flanges of the top and bottom plates; providing a second outer elastomeric member disposed between the second lateral flanges of the top and bottom plates; providing a central elastomeric member disposed between the central portion of the top and

bottom plates; providing a first substantially hollow portion disposed between the top plate and the bottom plate and between the central elastomeric member and the first outer elastomeric member; providing a second substantially hollow portion disposed between the top plate and the bottom plate and between the central elastomeric member and the second outer elastomeric member. The method further can include compressing the first and second outer elastomeric members; and engaging the adapter pad with the first roller bearing adapter such that movement of the bottom plate of the first adapter pad with respect to the roller bearing adapter is restricted. The first and second laterally projecting flanges of the top plate and the bottom plate and the first and second outer elastomeric members of each adapter pad can be entirely disposed above the vertical shoulders of the roller bearing adapter.

[0018] In another example, the disclosure provides a method for forming an adapter pad including providing a continuous top plate having a central portion, first and second upturned regions projecting upward from opposite edges of the central portion, a first lateral flange projecting outward from the first upturned region, and a second lateral flange projecting outward from the second upturned region; providing a continuous bottom plate having a central portion, first and second upturned regions projecting upward from opposite edges of the central portion, a first lateral flange projecting outward from the first upturned region, and a second lateral flange projecting outward from the second upturned region; inserting a first outer elastomeric member between the first lateral flanges of the top and bottom plates; inserting a second outer elastomeric member between the second lateral flanges of the top and bottom plates; inserting a central elastomeric member between the central portion of the top and bottom plates; forming a first substantially hollow portion disposed between the top plate and the bottom plate and between the central elastomeric member and the first outer elastomeric member; forming a second substantially hollow portion disposed between the top plate and the bottom plate and between the central elastomeric member and the second outer elastomeric member; compressing the first outer elastomeric members; and compressing the second outer elastomeric members.

BRIEF DESCRIPTION OF THE DRAWINGS

- [0019] Figure 1A is a perspective view of a standard 3-piece truck.
- [0020] Figure 1B is an exploded view of a standard 3-piece truck.
- [0021] Figure 2 is a perspective view of a roller bearing adapter and adapter pad according to aspects of the disclosure.
- [0022] Figure 3 is a cross-sectional view of roller bearing adapter, adapter pad, and a side frame according to aspects of the disclosure.
- [0023] Figure 3A is a detail view of a portion of Figure 3.
- [0024] Figure 3B is a detail view of a portion of Figure 3.
- [0025] Figure 4 is a perspective view of a roller bearing adapter according to aspects of the disclosure.
- [0026] Figures 5A-5D are perspective views of roller bearing adapters according to aspects of the disclosure.
- [0027] Figure 6 is a cross-sectional view of the roller bearing adapter of Figure 4 taken along a centerline.
- [0028] Figure 7 is a top view of the roller bearing adapter of Figure 4.
- [0029] Figure 8 is a side view of the roller bearing adapter of Figure 4.
- [0030] Figure 9 is a front view of the roller bearing adapter of Figure 4.
- [0031] Figure 10 is a cross-sectional view taken along line A-A of Figure 8.
- [0032] Figure 11 is a top view of an adapter pad according to aspects of the disclosure.
- [0033] Figure 11A is a cross-sectional view taken along line A-A of Figure 11.
- [0034] Figure 11B is a cross-sectional view taken along line B-B of Figure 11.
- [0035] Figure 11C is a detail view of detail G of Figure 11.
- [0036] Figure 12 is a side view of a bottom plate of an adapter pad according to aspects of the disclosure.
- [0037] Figure 13A is a top view of an adapter pad according to aspects of the disclosure.
- [0038] Figure 13B is a cross-sectional view taken along the longitudinal line of Figure 13A.
- [0039] Figure 13C is a section view along the longitudinal center centerline of an adapter pad and a portion of a roller bearing adapter according to aspects of the disclosure.

- [0040]** Figure 13D is a perspective view of an adapter pad according to aspects of the disclosure with all elastomeric material removed including a ground strap.
- [0041]** Figure 13E is a perspective view of an adapter pad according to aspects of the disclosure including a ground strap.
- [0042]** Figure 14 is an exemplary graph depicting adapter pad lateral force vs. displacement according to aspects of the disclosure.
- [0043]** Figure 15 is an exemplary graph depicting temperature vs. time during loading of an adapter pad according to aspects of the disclosure.
- [0044]** Figure 16A is a top view of an adapter pad without the top plate according to aspects of the disclosure.
- [0045]** Figure 16B is cross-sectional view of adapter pad according to aspects of the disclosure.
- [0046]** Figure 17A is a top view of an adapter pad according to aspects of the disclosure.
- [0047]** Figure 17B is a top view of the adapter pad of Figure 17A depicting longitudinal displacement.
- [0048]** Figure 17C is a top view of the adapter pad of Figure 17A depicting lateral displacement.
- [0049]** Figure 17D is a top view of the adapter pad of Figure 17A depicting rotational displacement.
- [0050]** Figure 18 is a depiction of a method of manufacturing an adapter pad according to aspects of the disclosure.
- [0051]** Figure 19 is a perspective view of an elastomeric member of an adapter pad according to aspects of the disclosure.
- [0052]** Figure 20A-C are vertical sectional views of a portion of an adapter pad according to aspects of the disclosure showing various geometries for the plurality of gaps, with the adapter pad in an unloaded configuration.
- [0053]** Figure 21A-C are each views of the respective Figures 20a-20c schematically showing the geometry of the gaps altered when load is applied to the adapter pad.

[0054] Figure 22 is a sectional view of a portion of an adapter pad according to aspects of the disclosure, showing a representative alignment of the plurality of gaps within the elastomeric portion.

[0055] Figure 23 is a sectional view of a portion of the adapter pad according to aspects of the disclosure showing a plurality of gaps extending only a partial thickness of the elastomeric layer.

[0056] Figure 24 is a depiction of a method of manufacturing an adapter pad according to aspects of the disclosure.

[0057] Figure 25 is a depiction of a method of manufacturing an adapter pad according to aspects of the disclosure.

[0058] Figures 25A-25I are perspective views of adapter pads according to aspects of the disclosure.

[0059] Figure 26 is a depiction of a method of manufacturing an adapter pad according to aspects of the disclosure.

[0060] Figure 27 is an exemplary graph depicting testing of an adapter pad according to aspects of the disclosure.

DETAILED DESCRIPTION

[0061] In the following description of various example structures according to the invention, reference is made to the accompanying drawings, which form a part hereof, and in which are shown by way of illustration various example devices, systems, and environments in which aspects of the invention may be practiced. It is to be understood that other specific arrangements of parts, example devices, systems, and environments may be utilized and structural and functional modifications may be made without departing from the scope of the present invention. Also, while the terms "top," "bottom," "front," "back," "side," "rear," and the like may be used in this specification to describe various example features and elements of the invention, these terms are used herein as a matter of convenience, e.g., based on the example orientations shown in the figures or the orientation during typical use. Additionally, the term "plurality," as used herein, indicates any number greater than one, either disjunctively or conjunctively, as necessary, up to an infinite number. Nothing in this specification should be construed as requiring a specific

three dimensional orientation of structures in order to fall within the scope of this invention. Also, the reader is advised that the attached drawings are not necessarily drawn to scale.

[0062] In general, aspects of this invention relate to a railcar truck, and railcar truck roller bearing adapters and adapter pads. According to various aspects and embodiments, the railcar truck and the railcar truck roller bearing adapters and adapter pads may be formed of one or more of a variety of materials, such as metals (including metal alloys), polymers, and composites, and may be formed in one of a variety of configurations, without departing from the scope of the invention. It is understood that the railcar truck roller bearing adapters and adapter pads may contain components made of several different materials. Additionally, the components may be formed by various forming methods. For example, metal components, may be formed by forging, molding, casting, stamping, machining, and/or other known techniques. Additionally, polymer components, such as elastomers, can be manufactured by polymer processing techniques, such as various molding and casting techniques and/or other known techniques.

[0063] The various figures in this application illustrate examples of railcar trucks, railcar truck roller bearing adapters, and adapter pads according to this invention. When the same reference number appears in more than one drawing, that reference number is used consistently in this specification and the drawings refer to the same or similar parts throughout.

[0064] As shown in Figures 1A and 1B, a typical railroad freight car truck includes an assembly made up of two wheel sets 1 each including two wheels 2, two side frames 4, one bolster 6, two spring groups 8, a friction damping system, and four adapters 10. Figures 1A and 1B depict an example truck assembly.

[0065] The side frames 4 are arranged longitudinally, e.g., in the direction of the rails upon which the truck sits. The bolster 6 is aligned transversely or laterally with respect to the side frames 4 and extends through the middle of each side frame 4.

[0066] The bolster bowl 12 is the round section of the bolster 6 that includes a rim that protrudes upward. The body centerplate of the car body rests in the bolster bowl 12 and acts as a rotation point for the truck and car body. It is at this interface that the majority of the vertical load of the freight car is reacted. Usually, the bolster

bowl 12 is equipped with wear plates or a wear liner so that the bolster casting 6 is prevented from wear during the service life of the freight car. Also on the top surface of the bolster 6 and located 25 inches off the centerline are the side bearings 14, which can help stabilize the car body and can provide some prevention of truck hunting if they are of the constant contact type. The side bearings 14 shown in Figure 1B are not of the constant contact type but rather consist of rollers and a cage.

[0067] The bolster 6 rests on top of spring groups 8 that are supported underneath by the spring seat of the side frames. Additional springs, often called snubber or side springs 17, can also be part of the spring group and rest on the spring seat extending upward to the bottom of friction wedges 16 that can be part of the friction damping system.

[0068] The friction wedges 16 can be located in pockets at the end of and to each side of the bolster 6. The friction wedge pockets of the bolster can be angled, typically at an angle of about 60° from horizontal matching the angle surface of the friction wedges. The opposite face of a friction wedge 16 is typically vertical and contacts what is called the column face of the side frame. The spring force of the snubber springs 17 pushes the friction wedge 16 against the angled surface of the bolster friction wedge pocket which creates a reaction force against the vertical column face of the side frame.

[0069] As the bolster 6 moves up and down under the load from the freight car resting on the truck, the sliding of the friction wedge 16 against the column face can create column friction damping. This damping can provide for a dissipation of energy that prevents the freight car from developing undesired vibrations/oscillations when moving in railroad service. It is also these forces acting between the bolster 6 and side frame 4 through the friction wedges 16 that seeks to prevent the truck from taking on a parallelogram geometry when under operation. Hard stops, such as the gibs and rotation stops, help prevent trucks from taking on an extreme parallel shape. This resistance to parallelogramming is often called warp stiffness.

[0070] As shown in Figures 1A and 1B, the wheel sets 1 of the truck assembly consist of two wheels 2, an axle 3, and two roller bearings 5. The wheels are press fit onto the raised wheel seats of the axle. The journal of the axles extend outboard

of the wheels and provide the mounting surface for the roller bearings 5. The roller bearings 5 are press fit onto the axle journals. The interface between the roller bearings 5 and the side frames 4 can consist of a bearing adapter 7. Typically railroad freight car trucks have been equipped with metal adapters that are precisely machined to fit on the roller bearings rather tightly while providing a looser fit to the steel side frame pedestals which envelope the interface between the roller bearings and the side frames. This interface provides a small movement between the wheel sets and the side frames which is controlled by the vertical load that exists from the freight car and the frictional forces that exist between the sliding metallic surface on top of the adapter, referred to as the adapter crown, and the bottom of the steel pedestal roof which is usually equipped with a steel wear plate.

[0071] Because the vertical load varies with the lading weight contained in the freight car and with the rocking motion of the freight car on the truck, the frictional forces at the metal adapter crown and steel pedestal roof wear plate can vary considerably and are not controlled in the typical truck. This metal to metal connection requires large wheelset forces to force sliding at the interfacing surface due to the stick-slip nature of metal sliding connections. More recent truck designs, such as those trucks qualified under the American Association of Railroads (“AAR”) M-976 specification, now include an adapter pad at the interface between the steel adapter and the pedestal roof.

[0072] Some adapter pad systems have been successful in lowering wheelset forces during railcar curving by allowing low stiffness compliance between the side frame and axle. This added compliance created by the adapter pad also reduces the force it takes to pull or push a railcar through a curve as required in the M-976 specification, which is incorporated herein by reference. Adversely, these designs have lowered the speed at which the car resonates during tangential track travel, otherwise described as lowering the hunting speeds of the cars. Lowering the hunting speed is a disadvantage because it limits the operating speeds of the trains and increases the risk of derailling cars or damaging track. Other designs utilize premium side frame squaring devices such as transoms, frame bracing, steering arms, spring planks, yaw dampers, cross bracing, or additional friction wedges to improve the hunting performance. These systems, generally referred to as premium

truck technology, typically increase the wheelset forces and therefore the pulling resistance during curving. In addition to increasing curve resistance, these designs have traditionally increased truck maintenance costs due to the added wear components and system complexity.

[0073] Adapter pad system embodiments described herein can meet the curving performance criteria set forth in M-976, without decreasing the critical hunting threshold. The adapter pad systems described herein also do not require any additional side frame squaring devices, such as transoms, frame bracing, steering arms, spring planks, yaw dampers, cross bracing, or additional friction wedges, to be added to a standard 3-piece truck. The resulting truck system described herein can improve the life of the wheelsets, maintain a high hunting threshold, improve the durability of the pad system, and minimize wear and forces exerted on the rails.

[0074] By way of background, there are many different rail car types and services native to the North American Rail Industry which require different truck sizes. Cars designed for 70 ton service have a Gross Rail Load of 220,000 lbs., and commonly use 28 inch or 33 inch wheels with 6 inch x 11 inch bearings. Cars designed for 100 ton service have a Gross Rail Load of 263,000 lbs., and commonly use 36 inch wheels with 6.5 inch x 12 inch bearings. Cars designed for 110 ton service have a Gross Rail Load of 286,000 lbs. and must meet the performance specification M-976 as mentioned above. These 110 ton cars typically use 36 inch wheels with 6.5 inch x 9 inch bearings. The final car type typical to North America is designed for 125 ton service and has a Gross Rail Load of 315,000 lbs. This car type typically uses 38 inch wheels with 7 inch x 12 inch bearings. The other truck sizes – 70 ton, 100 ton, and 125 ton are not subject to the same strict performance standard, and thus have not required the use of pads to date.

[0075] The roller bearing adapter and matching adapter pad are the focus of this application. Embodiments of the disclosed adapter and matching adapter pad system can be used with cars designed for 110 ton service and can be scalable for use with and improve the performance of trucks for all car capacities (including 70 ton, 100 ton, 110 ton, and 125 ton), including those trucks that do not require compliance with the M-976 standard.

[0076] One embodiment of the adapter pad system 198 is shown in at least Figures 2 and 3. The adapter pad system 198 may comprise a roller bearing adapter 199 and an adapter pad 200 configured to be disposed between a wheelset roller bearing or roller bearing 5 and a side frame pedestal roof 152 of a three-piece railcar truck. The side frame can include first and second outer sides 154, 156. The adapter pad 200 also includes an elastomeric member 360 that supports the vertical load and allows for low force longitudinal, lateral, and rotational motion of the top plate 220 (engaged with the side frame) relative to the bottom plate 240 (engaged with the roller bearing adapter) as compared to a traditional steel-steel sliding adapter system.

[0077] In some embodiments, as shown in at least Figures 2-3, the adapter pad system 198, when installed within a truck system is compressed with a constant vertical load, due to the weight of the railcar and truck components that are carried by the adapter pad 200 and ultimately transferred to the track through the wheel sets. While the vertical load that is imparted upon the central portion of the adapter pad 200 naturally varies with the different loading of the railcar, it has been assumed that a vertical load can be about 35,000 pounds per adapter pad for about a corresponding 286,000 gross rail load car.

[0078] It has been determined through testing that the performance of the truck system is highly influenced by the stiffness of the adapter pad 200. More specifically, in certain embodiments, it has been determined that truck performance can be improved with improved adapter pad system performance. The adapter pad system performance can be improved by increasing the stiffness of the adapter pad system 198 (measured in pounds of force per inch of displacement). Additionally, for example, it has been determined that acceptable life expectancy (measured in distance traveled under load of a truck system that includes an adapter pad 200 installed, which a design life has been determined to be 1 million miles of railcar travel) is expected for an adapter pad 200 like embodiments discussed herein when a longitudinal stiffness is at least 45,000 pounds per inch or in the range of about 45,000 pounds per inch to about 80,000 pounds per inch, and/or when a lateral stiffness is at least 45,000 pounds per inch or in the range of about 45,000 pounds per inch to about 80,000 pounds per inch, and/or when a rotational stiffness (i.e.

stiffness to resist rotation about the vertical axis) is at least 250,000 pound * inches per radian or in the range of about 250,000 pound * inches per radian to about 840,000 pound*inches per radian (each of these measured when a 35,000 pound vertical load is applied to the central portion of the adapter 200). These unique stiffness combinations can maximize the hunting threshold speed, while still maintaining a curve resistance below 0.40 lbs/ton/degree of curvature as required by the M-976 specification without the use of premium truck technologies utilizing transoms, frame bracing, steering arms, spring planks, yaw dampers, cross bracing, or additional friction wedges to improve performance.

[0079] Stiffness of the adapter pad system is quantified by measuring the adapter assembly resistance to relative shear displacement of the top plate (which is engaged with the side frame), and the bottom plate (which is engaged with the roller bearing adapter). To determine the stiffness, the adapter assembly can be displaced relative to the side frame in multiple directions, such as, longitudinal (in the direction of railcar travel), lateral (across the rail tracks), yaw (rotation about a vertical axis and in line with axle center line), and vertical (between side frame pedestal roof and adapter pad top surface). A vertical load of 35,000 should be maintained during shear stiffness testing to simulate a loaded car scenario.

[0080] During testing, the force to displace the top plate relative to the bottom plate can be measured using load cells attached to a force actuator. Displacement measurements can be collected with displacement transducers, dial indicators, potentiometers, or other displacement measuring instruments. As described in more detail below, the force and displacement is plotted, with the slope of the hysteresis loop indicating the stiffness in the respective direction. The area contained within the loop is proportional to the energy displaced during the load cycle.

[0081] Embodiments of the adapter pad system 198 described herein provide a thrust lug opening width and spacing sufficient to not limit displacement within the AAR values, even with the use of high stiffness shear pads as described herein. The disclosed adapter design may utilize target adapter displacements shown in Table 1 below.

Table 1

<p>AAR ADAPTER TO SIDE FRAME CLEARANCE STACKUP NEW COMPONENTS</p>
--

Features	Nominal	Maximun	Minimun
Longitudinal Clearance (Each direction from center: in.)	.047	.139	.017
Lateral Clearance (Each direction from center: in.)	.156	.234	.126
Rotataional Clearance (Each direction from center: mRad.)	26.1	41.0	9.2

[0082] Disclosed embodiments of the adapter pad system 198 with the disclosed longitudinal, lateral, and rotational shear stiffness as described herein can provide an advantageous combination of high speed stability and low curve resistance for the 3-piece truck system. Disclosed embodiments of the adapter pad system 198 can increase the warp restraint of the 3-piece truck system as compared to other adapter pad designs. This can allow for increased high speed stability. In addition to improvements in high speed stability, embodiments of the adapter pad system 198 described herein can promote longitudinal displacement of the wheelset during curving, allowing the leading and trailing axle of the truck assembly to develop an inter-axle yaw angle proportional to the curve which can lower wheelset forces. In combination, the adapter pad system 198 promotes lateral wheelset shift to develop an optimal rolling radius difference during curving. The adapter pad system stiffness and displacement ranges disclosed herein can allow for optimal inter-axle yaw angle and lateral wheelset shift, promoting low wheelset force solution through curves. Reduction in curving forces and improved high speed stability can contribute to improvements in wheelset and rail life.

[0083] Some adapter pad designs utilize multiple elastomer layers to reduce shear strain. These multiple layers can add significant thickness to the adapter system and when used in conventional trucks, raise the height of the car. Raising the height of the car creates issues coupling to other cars, as well as raises the center of gravity. As a result some designs required the use of special, non-conventional side frames to minimize the height difference. Embodiments discussed herein can allow for improved dynamic performance, without requiring the use of special, non-conventional truck components.

[0084] Embodiments discussed herein can be used with side frames having AAR standard geometry, including AAR standard pedestal geometry and AAR standard thrust lug clearances, as described in the Association of American Railroads Manual

of Standards and Recommended Practices, Section SII (10/25/2010), Specification S-325 (6/11/2009) – "Side Frame, Narrow Pedestal - Limiting Dimensions" which is incorporated herein by reference. AAR standard pedestal geometry can be described as including nominal longitudinal thrust lug spacing of about 7.25 - 8.25 inches; nominal thrust lug width of about 3.5-3.75 inches; nominal longitudinal jaw spacing of about 8.88-11.06 inches; and nominal pedestal roof height above the centerline of the axle of about 5.38 - 6.89 inches. Embodiments of the adapter pad system 198 disclosed herein can be used with existing and/or standard 3 piece truck systems, including truck systems having AAR standard geometry as described in the Association of American Railroads Manual of Standards and Recommended Practices, and more specifically, Section H (1/1/2012), Specification M-924 (2/1/2014) - "Journal Roller Bearing Adapters for Freight Cars" which are incorporated herein by reference. AAR standard thrust lug clearance can be found above in Table 1 for new casting manufacturing dimensions. The thrust lug clearance is determined through the distance between the pedestal area and the roller bearing adapter openings. Standard AAR adapter dimensions can include nominal longitudinal thrust lug bearing surface spacing of about 7.156 - 8.656 inches; and a nominal lateral thrust lug opening of about 3.812 - 4.062 inches. Embodiments of the adapter pad system 198 described herein can also meet American Association of Railroads ("AAR") M-976 specification (AAR Manual of Standards and Recommended Practices, Section D (9/1/2010), Specification M-976 (12/19/2013) - "Truck Performance for Rail Cars") which is incorporated herein by reference. For example, embodiments of the adapter pad system 198 can be used in existing and/or standard 3 piece truck systems without the use of additional pieces such as transoms, frame braces, or spring planks. Additionally, for example, adapter pad systems 198 disclosed herein can fit between the roller bearing 5 and the pedestal roof 152 of existing trucks. Thus, adapter pad systems 198 disclosed herein can have a total height measured between an upper surface of the roller bearing 5 and the pedestal roof 152 of about 1.3 inches or in the range of about 1.1 inches to about 1.5 inches. While the embodiments described herein are specific to the 110T truck, the disclosed adapter and matching adapter pad system can be scalable for use with and improve the performance of trucks for all car capacities (70

ton, 100 ton, 110 ton, and 125 ton), including those trucks that do not require compliance with the M-976 standard.

[0085] A roller bearing adapter 198 in accordance with the present disclosure is shown in Figures 4-10. As shown in Figure 4, the roller bearing adapter 199 includes a pedestal crown surface 102. The pedestal crown surface or top surface 102 can in some embodiments be a crowned or curved surface such that the central area of the pedestal crown surface is higher than the lateral edges. Thus, the pedestal crown surface 102 can be generally flat in the longitudinal direction and curved in the lateral direction. The pedestal crown surface 102 can be an AAR standard pedestal crown surface but can have a thinner cross-sectional thickness than a typical roller bearing adapter. For example, in some embodiments, the roller bearing adapter thickness can be between about 0.6 inches thick (measured from the bearing surface 117 to the pedestal crown surface 102 at the centerline) to about 0.75 inches thick and in some embodiments less than about 0.75 inches thick.

[0086] As shown in Figures 4-8 the roller bearing adapter 199 can have an overall height of about 4.83 inches or within the range of about 4 inches to about 6 inches; an overall length of about 9.97 inches or in the range of about 9 inches to about 11 inches; and an overall width of about 10 inches or at least 7.5 inches or in the range of about 9 inches to about 11 inches.

[0087] The roller bearing adapter 199 can include features to limit the motion of the adapter pad 200 relative to the roller bearing adapter 199. For example, the roller bearing adapter can include longitudinal adapter pad stops 104. As shown in Figure 4, the longitudinal pad stops 104 can be raised vertically relative to the lateral edges of the pedestal crown surface 102. The longitudinal adapter pad stops 104 are designed to interface with slots, recesses, or edges of the bottom plate 240 of the adapter pad 200 and can engage the adapter pad 200 such that the longitudinal motion of the adapter pad 200 can be restricted or controlled to a specified value while not restricting the lateral movement of the adapter pad. Although four longitudinal adapter pad stops 104 are shown in Figure 4, any number or design of longitudinal pad stops can be used, including continuous longitudinal pad stops that extend the entire length of the lateral edge of the pedestal crown surface 102. Examples of other possible longitudinal stops 104 are shown in Figures 5A-5D. For

example, the longitudinal stops 104 can comprise two bosses per lateral side as shown in Figure 5A. The longitudinal stops 104 shown in Figure 5A can interface with reliefs in the bottom plate 240 of the adapter pad 200 that can engage these stops 104 such that the longitudinal motion can be restricted. Similar to Figure 5A, Figure 5B shows three stops 104 that can restrain the longitudinal movement of the adapter pad 200 relative to the adapter 199 in the same way.

[0088] Longitudinal stops can be incorporated into other portions of the adapter pad. For example, as shown in Figures 5C and 5D, longitudinal stops 104 can be incorporated into the top surface of the vertical shoulder 106. Similarly, in these examples, reliefs in the bottom plate 240 of the adapter pad can fit around these stops 104 or bosses and provide longitudinal movement restraint of the bottom plate 240 relative to the top plate 220.

[0089] Various other combinations of sizes, shapes, and locations can be utilized for the longitudinal stops 104 in order to provide the desired restraint of movement.

[0090] As shown in Figures 4-8, the roller bearing adapter 199 also includes vertical shoulders 106. The vertical shoulders 106 can be raised vertically relative to the longitudinal edges of the pedestal crown surface 102. The vertical shoulders 106 are designed to improve the bending strength of the adapter 199 and minimize distortion of the adapter 199 under the high forces imparted by the adapter pad 200. By minimizing distortion of the adapter pad 200 under load, the vertical shoulders 106 can improve the load distribution to the roller bearing components and can improve bearing life. The vertical shoulders 106 are designed to interface with slots, recesses, edges, or surfaces of the bottom plate 240 of the adapter pad 200 such that the lateral motion of the bottom plate 240 is restricted or controlled to a specified value. In addition to limiting movement of the bottom plate, the vertical shoulders can provide vertical support to the laterally projecting flanges 116, 118 of the adapter pad 200 in some embodiments. The vertical shoulders 106 can extend laterally to 10 inches wide for a 6.5 inch x 9 inch adapter, and vertically about 1 inch above the standard pedestal crown surface. In some embodiments the upper surface of the vertical shoulders 106 can be up to about 0.75 inch or up to about 3 inches above the pedestal crown surface 102. The vertical shoulders may also be up to about 8 inches in the longitudinal direction. The vertical shoulders may be cast integral to

the adapter, and used on standard adapters for 70T, 100T, 110T, or 125T service. Although continuous vertical shoulders are shown, any number of vertical shoulders can be used. The width of the vertical shoulders can be at least 0.5 inches.

[0091] The roller bearing adapter 199 can also include features, such as the vertical shoulders 106, to improve the bending strength or cross-sectional moment of inertia of the adapter 199 to minimize distortion of the adapter 199 under the high forces imparted by the adapter pad 200. For example, for the embodiment shown in Figures 4, and 6-10, and more particularly shown in Figures 8 and 10, a cross-section of the adapter 199 can be taken approximately through the longitudinal center of the roller bearing adapter 199 as shown in Figures 8 and 10. As shown in Figure 10, a neutral Y-axis 108 can extend in the vertical direction through the lateral center of the adapter 199. A neutral Z-axis 110 can extend in the lateral direction about 5.2 inches, or in the range of about 5.0 inches and 5.5, above a center axis of an axle 111. The cross-sectional moment of inertia of the cross-section shown in Figure 10 around the neutral Z-axis 110, I_{z-z} , at the center of the adapter can be about 1.4 in^4 , or in the range of about 1.0 to about 2.0 in^4 . The cross-sectional moment of inertia around the neutral Y-axis 108 at the center of the adapter, I_{y-y} at the cross-section can be about 86.8 in^4 , or in the range of about 50 to about 100 in^4 . Adapter designs which do not utilize vertical shoulders have significantly lower area moment of inertia through lateral sections. For example, an adapter design as shown in Figure 10 but without vertical shoulders 106 at the same lateral centerline cross section can have a moment of inertia around the neutral Z-axis of about 0.2 in^4 and can have a moment of inertia around the neutral Y-axis of about 32.9 in^4 . The resulting lower moment of inertia compared to the disclosed adapter can result in a lower stiffness and higher stresses in the adapter under similar load configurations, and possibly reduced roller bearing performance.

[0092] The roller bearing adapter 199 may be made from one or more different types of alloys of steel that have suitable strength and other performance characteristics. For example, roller bearing adapter 199 may be manufactured from cast iron of grade ASTM A-220, A-536, or cast or forged steel of grades ASTM A-148, A-126, A-236, or A-201. In some embodiments, the entire roller bearing

adapter 199 is formed (cast, machined, pressed or another suitable metal forming operation) from a single monolithic member.

[0093] Moving now to the adapter pad 200 of the adapter system 198 which is configured to be disposed between and can engage with the roller bearing adapter 199 and the side frame pedestal roof 152 of the side frame 4. As shown in Figures 11-11C, and primarily Figure 11A, the adapter pad 200 generally includes an upper member or top plate 220 having an inner surface 222 and an outer surface 224, a lower member or bottom plate 240 having an inner surface 242 and an outer surface 244, and an elastomeric member 360 disposed between the inner surfaces 222, 242 of the top and bottom plates 220, 240 along a portion of the adapter pad 200. The adapter pad 200 includes a central portion 210 that is disposed under the lower surface of the pedestal roof 152 with each plate 220, 240 having a corresponding central portion 226, 246. The adapter pad 200 further includes first and second upturned regions 212, 214 and first and second lateral flanges 216, 218. The top plate 220 has corresponding first and second upturned regions 228, 230 projecting upward from opposite edges of the central portion 226 of the upper plate 220, a first lateral flange 232 projecting outward from the first upturned region, and a second lateral flange 234 projecting outward from the second upturned region 230. Similarly, the bottom plate 240 has corresponding first and second upturned regions 248, 250 projecting upward from opposite edges of the central portion 246 of the bottom plate 240, a first lateral flange 252 projecting outward from the first upturned region, and a second lateral flange 254 projecting outward from the second upturned region 250. As shown in Figure 3, the lateral flanges 216, 218 are disposed laterally outboard of the pedestal roof 152 when the truck system is assembled, and the central portion 210 is disposed below the pedestal roof 152. First and second upturned regions 212, 214 are disposed between the central portion 210 and the respective first and second lateral flanges 216, 218 and provide a transition therebetween.

[0094] Turning first to the central portion 210, which can in some embodiments comprise primarily three parts including the central portion 226 of the top plate, the central portion 246 of the bottom plate and the elastomeric member 360 disposed therebetween. As discussed above, the adapter pad 200 is disposed between the

side frame pedestal roof 152, which generally has a substantially flat horizontal engaging surface, and the roller bearing adapter 199 which can generally have a curved or crowned roof. As shown in Figure 11A and 12 the central portion 246 of the bottom plate 240 can have a curved lower surface 244 such that the outer surface 244 generally follows the curve or crown of the adapter 199. More specifically, in some embodiments the central portion 246 can have a greater thickness toward the edges 261, 262 of the central section 246 than at the center of the central section 246. For example, as shown in Figure 12, the thickness at the center of the center portion 246 can be about 0.15 inches or in the range of about 0.06 inches to about 0.35 inches and the thickness at the edges 261, 262 can be about 0.26 inches or in the range of about 0.15 inches to about 0.5 inches.

[0095] In some embodiments, the central section 226 of the top plate 220 can include an outer surface 224 and an inner surface 222 that are substantially horizontal and parallel as shown in Figure 11 A. The thickness of the center portion 226 of the top plate 220 can be about 0.28 inches or in the range of about 0.15 inches to about 0.4 inches. In such a system, the thickness of the elastomeric section 360 can be substantially similar throughout the central portion 210 which can in some embodiments increase performance characteristics.

[0096] It has been found that an elastomeric section having a uniform thickness can in some circumstances have certain advantages. For example, in certain embodiments, linear thermal shrinkage can be constant along the length and width of the pad if the plurality of elastomer layers have common length and width dimensions among all members. For example, in some embodiments, during molding the rubber forming the elastomeric member can be injected into the mold at around 300 degrees Fahrenheit, and it can subsequently cool to room temperature. Linear thermal shrink normal to the shear plane can be related to the section thickness "T" the change in temperature, and the coefficient of thermal expansion. A non-uniform elastomer thickness can result in non-uniform shrinkage during the cooling process. Non-uniform shrinkage can result in residual tensile stresses in the areas last to cool which can negatively impact fatigue life.

[0097] With further reference to Figures 11-11C, and primarily Figure 11C, in some embodiments, the first and second upturned portions 228, 230 of the top plate

220 can include an outer planar portion 228a, 230a (only the first upturned region shown in Figure. 11C) and an inner planar portion 228d, 230d. In some embodiments, the planar portions 228a, 230a and 228d, 230d can extend at an angle Δ with respect to a plane P that extends along the outer surface 224 of the center portion 226. In some embodiments, the angle Δ may be an obtuse angle and in some embodiments the angle can be within the range of about 95 degrees to about 115 degrees, such as 105 degrees, or any other angle within this range. In embodiments, as described in more detail below, where the first and/or second upturned portions 212, 214 include a grip, the planar surface may surround one or both sides of the grip, or may be alternatively arranged with respect to the grip. The first and second upturned portions 228, 230 of the top plate 220 can also include lower curved portions 228b, 230b and 228e, 230e that transition between the central portion 226 and the planar portions 228a, 230a and 228d, 230d. Similarly, the first and second upturned portions 228, 230 of the top plate 220 can also include upper curved portions 228c, 230c and 228f, 230f that transition between the lateral flanges 232, 234 and the planar portions 228a, 230a and 228d, 230d. The upper or lower curved portions 228b, 230b, 228e, 230e, 228c, 230c, 228f, and 230f may be formed with a constant curvature and/or a varying curvature. The bottom plate 240 can include similar planar portions and upper and lower curved regions. The upturned regions 212, 214 may in some embodiments not include a planar portion and may be formed with a constant curvature and/or a varying curvature.

[0098] With further reference to Figure 11A, the first and second lateral flanges 216, 218 can extend laterally outside of the side frame 4 and are disposed at a vertical height or in a plane that is different or above the central portion 210, which is disposed under and in contact with the pedestal roof 152. Accordingly, the first and second lateral flanges 216, 218 are disposed in a vertically raised position with respect to the central portion 210. The lateral projecting flanges 216, 218 can provide more area for elastomer, and as discussed below, can increase stiffness of the adapter pad. In some embodiments, as shown in Figure 13B, the outer surface 244 of the first and second lateral flanges 252, 254 of the bottom plate 240 may be about 0.92 inches above the outer surface 244 of the lowest edge of the bottom plate 240 or in the range of about 0.25 inches to about 2 inches. In some embodiments,

the first and second lateral flanges 216, 218 can include a planar and horizontal outer surfaces 224, 244, which can be parallel to the outer surface 244 of the central portion 226. In some embodiments, the outer surface 244 of the first and second lateral flanges 252, 254 of the bottom plate 240 can rest on the vertical shoulders 106 of the roller bearing adapter 199. In other embodiments, the outer surface 244 of the first and second lateral flanges 252, 254 of the bottom plate 240 does not contact the vertical shoulders 106. And in still other embodiments, the outer surface 244 of the first and second lateral flanges 252, 254 of the bottom plate 240 can indirectly contact the vertical shoulders 106 through another piece such as a compression shim. As will be discussed in more detail below, in some embodiments, about 10 percent to 30 percent of vertical force from the pedestal roof 152 can be distributed to each of the adapter pad lateral flanges 216, 218 when a vertical force is applied to the central portion 210 of the adapter pad.

[0099] Although the embodiment of the adapter pad 200 shown in at least Figures 11-13 includes upturned portions 212, 214 and lateral flanges 216, 218, it need not include these portions in all embodiments. The center portion 210 can in some embodiments be used without the lateral flanges 216, 218 and/or without the upturned portions 212, 214, although such designs may affect performance. In an embodiment, the lateral flanges 216, 218 can extend from the central portion without upturned portions, and without decreased performance characteristics. Similarly, in some embodiments the lateral flanges can extend outside of the central portion but in the same plane as the central portion. In still other embodiments, the adapter pad 200 can include downturned portions that can connect to lateral flanges.

[00100] The top plate 220 may be made from one or more different types of alloys with suitable strength and other performance characteristics. For example, the top plate 220 may be manufactured from ASTM A36 steel plate, or steels with a strength equivalent to or higher than those specified in ASTM A-572. In some embodiments, the entire top plate 220 is formed (cast, machined, pressed, rolled, stamped, forged or another suitable metal forming operation) from a single monolithic member. In some embodiments, the top plate 220 may be formed from a material with a constant thickness throughout. In other embodiments, the top plate 220 has a variable thickness. For example in some embodiments, the lateral flanges

232, 236 of the top plate 220 can have a thickness that is greater than or less than the thickness of the center portion 226. Similarly and as previously discussed, the bottom plate 240 can have a constant or variable thickness. In some embodiments, one, some, or all of the corners 233 of the top plate 220 may be curved.

[00101] In some embodiments, the outer surface 226 of the top plate 220 may receive a coating of an elastomeric material 265 which may be the material that contacts the pedestal roof 152. As discussed elsewhere herein the elastomeric layer 265 may provide dampening and a calibrated flexibility to the pad, as well as a compressible surface to minimize wear between the adapter pad 199 and the pedestal roof 152. The elastomeric coating 265 may be formed with a flat outer surface that follows along the geometric profile of the steel portion of the top plate 220, and can have a uniform thickness, either along the entire top plate 220, or in other embodiments, a uniform thickness within discrete portions of the pad (such as a uniform thickness in the central portion 210, a (potentially different or potentially the same) uniform thickness on one or both of the upper portions lateral flanges 232, 234, a (potentially different or potentially the same) uniform thickness on one or both of the upturned portions 228, 230, and the like.

[00102] During use, there can be heat generation in the adaptor pad 200 through friction of the pad 200 and sliding relative to the side frame pedestal roof 152 and/or relative to the bearing adaptor 199; and or the hysteretic damping of the elastomeric member 360 of the adaptor pad 200. These heat sources can cause adaptor pad temperatures to increase, which can result in lower durability and reduced stiffnesses.

[00103] In some embodiments, the first and second lateral flanges 216, 218 can include upper and lower surfaces exposed to air outside of the side frame envelope at the pedestal area (when the adapter pad is installed within a pedestal of a truck). The exposed surfaces can readily allow for heat loss from the adapter pad during operation of the railcar (acting as a fin) and can cause net heat flow from the central portion 210 of the adapter pad 200) and toward the lateral flanges 216, 218. As is easily understood, and as discussed below, heat is generated within the adapter pad 200 during railcar operation due to various reasons, such as due to friction that resists relative translation or rotation between the adapter pad 200 and

the side frame and between the adapter pad 200 and the bearing adapter 199. Further, because the adapter pad 200 is in surface-to-surface contact with the side frame 4 and the bearing adapter 199, the adapter pad 200 may receive heat that is generated elsewhere and transferred to the adapter pad 200. Also, the cyclic dampening of the elastomeric portion produces heat. This heat must be ultimately removed to avoid a significant increase in the temperature of the components of the adapter pad 200 to increase the life of the components, as well to decrease the possible design constraints that might be necessary if the adapter pad 200 (or portions of the adapter pad 200) continuously operate with higher temperatures absent heat removal. This heat flow out of the adapter pad 200 may assist with the thermal design of the adapter pad 200 and the remainder of the truck system, which can have various design benefits such as broadening the possible elastomeric material choices, as well increasing the life of the elastomeric material by reducing its operating temperature, as other possible benefits.

[00104] In some embodiments, the adapter pad 200 can include additional features that can increase its ability to reduce heat in the adapter pad 200. For example, in some embodiments, first and/or second lateral flanges 216, 218 may include a portion that extends laterally from the side walls of the side frame pedestal area. During use, the laterally projecting flanges are in direct contact with airflow generated by the moving car, as opposed to the central portion which is insulated by the metal roller bearing adapter and the steel side frame pedestal region. These laterally projecting flanges can provide free surface area to transfer heat to atmosphere from the adapter pad 200. This can help dissipate heat from the hysteretic cycling of the elastomer, temperature increases of the roller bearing, and any other heat in the adapter pad 200. In certain embodiments, having first and/or second lateral flanges 216, 218 the operating temperature of the adapter pad system 198 can be reduced. For example under normal lateral shear cycling, as described below, the temperature differential between the lateral flanges 216, 218 and the center of the pad using a 5 mph constant velocity airflow over the first and second lateral flanges 216, 218 can be about 15 degrees Fahrenheit or in the range of about 5 degrees Fahrenheit to about 25 degrees Fahrenheit. Increased temperature

transfer from the center of the pad to the lateral flanges can allow for further increased heat transfer to atmosphere, and therefore improved durability.

[00105] In some embodiments, one or both of the outer surface 224 of the central portion 226, or the inner surface 244 of the central portion 246 may include one or more of various surface features, and in some embodiments a pattern of surface features to make these surfaces non-smooth. For example, the upper surface may include one or more of bumps, ridges and valleys, roughened surfaces, “sticky” surfaces, and the like. These surfaces can be created through a number of methods including shot blasting surface, machining the surface, applying different substances such as different types of rubbers to the surface and the like. These surface features, when provided, may reduce the potential for lateral and/or longitudinal sliding, and/or relative rotation of the adapter pad with respect to the pedestal roof 152, which may improve adapter pad 200 dynamic loading and strength performance, and may also reduce localized heat generation within the adapter pad 800 due to friction between the adapter pad 200 and the pedestal roof 152, which must be removed from the adapter pad 200 (as discussed elsewhere herein). Similarly, a thermal barrier coating such as ceramic or porcelain can be applied to top or bottom plates 220, 240. Optionally, a thermal barrier plate can be used to thermally isolate the heat generated from the frictional sliding during the high amplitudes. This can be done in conjunction with the wear plate that is typically used with the steel-on-steel adapter plates. The plate can be formed such that an air gap is maintained and the contact areas located to the outside edges of the adapter.

[00106] The bottom plate 240 may be formed from a similar construction and materials as the top plate 220. Similarly, the outer surface 244 of the bottom plate can include surface treatments and coatings of an elastomeric material 265 as the top member.

[00107] In some embodiments the entire or a majority of adapter pad 200 can include a coating of an elastomeric material 265, as shown for example in Figure 13C and Figure 13E. In some embodiments, for example, the coating of elastomeric material may contact the pedestal roof 152, the side frame 4, and the roller bearing adapter pad 199, including the pedestal crown surface 102 and the vertical shoulders 106. In other embodiments, for example, the portions of the adapter pad

200 that contact the pedestal roof 152, side frame 4, and the roller bearing adapter pad 199, can be free of elastomeric material. As discussed elsewhere herein, the elastomeric layer 265 may provide dampening and a calibrated flexibility to the pad, as well as a compressible surface to minimize wear between the adapter pad 200, the pedestal roof 152, and the roller bearing adapter 199. The elastomeric coating 265 may follow the outer surfaces of the adapter pad 200 and can have a uniform thickness, along the outer surfaces of the adapter pad 200, or in other embodiments, a uniform thickness within discrete portions of the pad such as a uniform thickness in the central portion 210, a (potentially different or potentially the same) uniform thickness on one or both of the upper portions lateral flanges 232, 234, a (potentially different or potentially the same) uniform thickness on one or both of the upturned portions 228, 230, and the like.

[00108] In some embodiments, it may be possible to use an electrically conductive additive in the elastomeric materials discussed herein to provide electrical conductivity and shunting ability through the top and bottom plates 220, 240. These additive particles may include materials such as nickel plated graphite, silver plated aluminum, or silver plated copper. The quantity of these additives may be as little as 0.5% of the total elastomer volume to provide sufficient electrical conductivity. Similarly, to create an electrical connection between the truck side frame to the adapter, a flexible conductor can be molded into the elastomeric pad connecting the upper pad plate to the bottom plate. The encasement of the conductor can protect the conductor from environmental corrosion. Its flexibility allows it to flex as the elastomeric (e.g., rubber) material strains. In some embodiments, as shown in Figures 13D-13E, the electrical continuity between the side frame 4 and adapter 199 is enabled through the use of a wire ground strap 266. As shown in Figures 13D-13E, the wire ground strap 266 can be attached to the top and bottom plates 220, 240 using apertures 267 that can be less than about 0.20 inches from the edge of the plate. The wire ground strap 266 passes through the apertures 267 in the top and bottom plates 220, 240. The edges of the plates can be indented or deformed 268 to crimp or secure the wire ground strap 266. In some embodiments, the wire ground strap 266 may be stainless steel braid, about .100 inches in diameter, but may be as small as .050 inches.

[00109] In some embodiments, as shown in Figure 11, the adapter pad 200 is constructed such that it is symmetrical about a lateral vertical plane that cuts through the geometric center C of the adapter pad (depicted as cutting through line B in Figure 11) and/or symmetrical about a longitudinal vertical plane that cuts through the geometric center C of the adapter pad 200 (depicted as cutting through line A in Figure 11).

[00110] In some embodiments, the outer lateral edges 281, 282 of the lateral flanges of the top and bottom plates 220,240 are each aligned along the same vertical plane, as best shown in Figure 11C. In these embodiments, the lateral length of the lateral flange of the bottom plate 240 is less than the lateral length of the lateral flange of the top plate 220.

[00111] Exemplary dimensions of the adapter pad 200 are shown and described in this application; however, other dimensions may be used for portions of the adapter pad, depending upon the fixed dimensions of the side frame and the bearings used with the particular railcar truck system.

[00112] The adapter pad 200 can, in some embodiments, as shown for example in Figures 3 and 11-11C, also include pads or grips on top and bottom plates 220, 240 of the adapter pad which can be configured to position the adapter pad 200 relative to the side frame pedestal roof 152 and the bearing adapter 199 and also engage and restrict movement of the adapter pad 200 relative to the pedestal roof 152 and the bearing adapter 199 which can focus movement (i.e. shear) of the adapter pad 200 to the elastomeric member 360. The assembly of the adapter pad 200 to the roller bearing adapter 199 can force the adapter pad 200 to be reasonably centered with regard to the roller bearing adapter 199, and the bearing by the use of the vertical shoulders 106 and including grips. Further, the adapter pad system 198 promotes the return of the adapter 200 and wheelset to a centered, or near zero force center position.

[00113] For example, the adapter pad 200 can include a first lateral adapter grip 270 disposed between the first vertical shoulder 106 of the adapter 199 and the first upturned region 248 of the bottom plate 240; and a second lateral adapter grip 271 disposed between the second vertical shoulder 106 of the adapter 199 and the second upturned region 250 of the bottom plate 240. The lateral adapter grips 270,

271 can run the entire longitudinal length of the adapter pad 200 or a portion of the longitudinal length of the adapter pad 200. In other embodiments, the lateral adapter grips 270, 271 can comprise a plurality of lateral adapter grips that run the entire lateral length of the adapter pad 200 or any portion thereof.

[00114] The lateral adapter pad grips 270, 271 can be integrally formed with the bottom plate 240, including with being integrally formed with any elastomeric coating 265 on the adapter pad 200. In other embodiments the lateral adapter pad grips 270, 271 can be integrally formed with the adapter 199. In still other embodiments, the lateral adapter pad grips 270, 271 can be attached to the adapter 199 and/or adapter pad 200 through use of adhesives or other known methods.

[00115] The adapter pad 200 can also include a first lateral side frame grip 272 disposed on the outer surface 224 of the first upturned region 228 of the top plate 220; and a second lateral side frame grip 273 disposed on the outer surface 224 of the second upturned region 230 of the top plate 220. In some embodiments, the first lateral side frame grip 272 can be disposed on the outer surface 224 of the first lateral flange 232 of the top plate 220; and the second lateral side frame grip 273 is disposed on the outer surface 224 of the second lateral flange 234 of the top plate 220. The lateral side frame grips 272, 273 can run the entire longitudinal length of the adapter pad 200 or a portion of the longitudinal length of the adapter pad 200. In other embodiments, the lateral adapter grips 272, 273 can comprise a plurality of lateral adapter grips that run the entire lateral length of the adapter pad 200 or any portion thereof.

[00116] The grips 270, 271, 272, 273 can be formed of an elastomeric material or any other suitable material and can in certain embodiments act to properly position the adapter pad 200 with respect to the side frame pedestal 152 and the adapter 199. Additionally, the first and second lateral adapter grips 270, 271 can be configured to reduce or eliminate sliding between the adapter 199 and the bottom plate 240 of the adapter pad 200. Similarly, the first and second lateral side frame grips 272, 273 can be configured to reduce or eliminate sliding between the outer surface 224 of the top plate 220 and the pedestal 152. This can in certain embodiments, reduce or eliminate sliding between the mating surfaces of adapter 199 and the adapter pad 200, and between mating surfaces of the side frame

pedestal roof 199 and the adapter pad 200 during operation of the system.

Additionally, this reduction of sliding between the contacting surfaces can in some embodiments reduce heat generated by any such sliding.

[00117] As discussed above, the grip features can significantly reduce relative motions between the horizontal surfaces of the adapter pad system by maintaining close-fitting contact between the vertical mating surfaces of the adapter pad assembly. Reduction of relative motions between the side frame pedestal 152 and the adapter pad 200 can improve the stiffness behavior of the adapter pad 200. As shown in Figure 14 comparing lateral stiffness, for example, in an adapter pad system with and without grips, improvement can be seen at the end of the stroke where instead of sliding, the adapter pad/pedestal interface shows more resistance for longer lateral travel than an adapter pad system that does not include grips. Reduced sliding between the parts can also reduce physical wear of the adapter pad system.

[00118] In certain embodiments, heat can be generated by movement of the adapter pad 200 relative to the roller bearing adapter 199 and the pedestal roof 152. This heat is generated by the hysteresis of the elastomer material cycling in shear displacement. As discussed above, excess heat can negatively affect the performance of the elastomeric member 360, and decrease the durability of the adapter pad. As shown in Figure 15 which compares adapter pad fatigue dynamic characteristics with and without grips, the adapter pad 200 with grips generates less heat when compared to an adapter pad 200 without grips. In some embodiments the adapter pad 200 will not exceed about 130 degrees Fahrenheit when the adapter pad 200 is positioned between the roller bearing adapter 199 and the pedestal roof 152 of a side frame of a moving railcar. In some embodiments, the adapter pad system 198 can be configured to restrict the elastomer temperatures below the degradation temperature of the specific elastomeric and/or adhesive materials used in pad construction and in some embodiments the adapter pad system can be configured to reduce melting of the elastomeric member.

[00119] As discussed above, and as shown primarily in Figures 16A-B, and 11B-C, an elastomeric member 360 is disposed between the top plate 220 and the bottom plate 240. The elastomeric member 360 supports the vertical load and

allows limited longitudinal, lateral, and rotational motion of the top plate 220 (supporting the side frame) relative to the bottom plate 240 (supported by the adapter). This allows the relative motion of the side frame relative to the adapter by a low stiffness, and hence, low loads as compared to sliding adapter designs. As shown in Figures 17A-17D the movement of the top plate 220 relative to the bottom plate 240 can be measured in longitudinal displacement (Figure 17B), lateral displacement (Figure 17C), and rotational displacement (Figure 17D). The adapter pad elastomeric material 360 may be a hysteretic material and have material damping during deflection cycling. This provides another energy absorption feature, depending on selection of the material and damping. For example, a material with too much damping may cause over heating of the elastomeric member 360 and reduce its short term stiffness and long term durability. The elastomeric member 360 may be formed from any suitable elastomeric materials, such as rubber, with suitable strength, flexibility, and stiffness characteristics. In some embodiments the material used for the elastomeric material should have a durometer (hardness) of Shore A 70 +/- 10. Elastomers that can be used can include, but are not limited to: natural rubber; nitrile; hydrogenated nitrile; butadiene; isoprene, or polyurethane and can have a durometer of about 60-80 Shore A.

[00120] In general the elastomeric member 360 can be attached to the top and bottom plates 220, 240 through injection molding. Generally the top and bottom plates 220, 240 can be placed within the mold. In some embodiments, portions of the top and bottom plates 220, 240 can be coated with adhesive to allow the elastomeric member 360 to adhere to the plates. Additionally, in some embodiments, spacers can be placed within the mold in certain areas where the elastomeric material is not needed. Once setup is complete, elastomeric material can be heated and inserted into the mold, and the elastomeric material can flow throughout the mold cavity, adhering to the areas applied with adhesive. The elastomeric can then undergo vulcanization and/or curing.

[00121] The elastomeric member 360 may provide for dampening within the adapter pad 200, allow for discrete changes in stiffness and/or flexibility within the adapter pad 200, and to allow for differences in the dampening, stiffness, flexibility or

other parameters within the different portions of the adapter pad 200 to allow for a suitable design.

[00122] As shown in Figure 11A, the elastomeric member 360 includes a central portion 362 that is disposed within the central portion 210 of the adapter pad 200, and first and second outer elastomeric members 364, 366 that are disposed within the respective first and second lateral flanges 216, 218. The outer elastomeric members 364, 366, increase the shear area and volume of the elastomer layer 360 by extending the elastomeric material beyond the standard adapter clearance envelope through the use of the lateral flanges 216, 218. This provides more area for the elastomeric member 360 and can increase stiffness of the adapter pad 200.

[00123] As best shown in Figure 16A, from a top view, the central elastomeric portion 362 can be generally square shaped and in some embodiments, as shown in Figure 16A can have one or more rounded corners 363. Rounded corners throughout the elastomeric member 360 can reduce or eliminate stress concentrations as compared to an elastomeric member 360 with square corners. As discussed above, the thickness of the elastomeric member 362 can have a uniform thickness throughout the central portion 210.

[00124] The central elastomeric portion 362 can be primarily disposed in the central portion 210, but in some embodiments can also be disposed in the first and second upturned regions 212, 214, as shown in Figure 16B, and in the lateral flanges 216, 218. As shown in Figure 16B, the central elastomeric member 362 can have a lateral length of about 6.7 inches or in the range of about 6.5 inches to about 10 inches. In some embodiments, and as shown in Figure 16B, the elastomer 360 can be disposed between the top and bottom plates 220, 240 in the upturned regions 212, 214. In embodiments where elastomer 360 is disposed between the plates in the upturned region it can compress or shear under lateral loading. This compression of the elastomer in the upturned regions 212, 214, in concert with the shearing of the elastomer in the other regions, can allow the adapter pad to reach high stiffnesses which can increase performance.

[00125] As best shown in Figure 16A, from a top view, the outer elastomeric portions 364, 366 within one or both of the first and second lateral flanges 216, 218 forms an outer edge 374, 376, respectively. The outer edge 374, 376 may be

disposed between the top and bottom plates 220, 240 such that a portion of one or both of the top or bottom plates 220, 240 extends radially outward past at least a portion of the outer edge 374, 376 of the elastomeric portion.

[00126] In some embodiments, the outer edge 374, 376 may be a longitudinal outer edge (374a, 376a) (i.e. may extend generally in the longitudinal direction when the adapter pad 200 is installed within a truck system) and may include a curved portion that is not in the same shape and alignment with the outer longitudinal edge of the top and/or bottom plates 220, 240. While the term “longitudinal outer edge” is used, this is meant to define the portion of the outer edge that extends between the opposed lateral edges 280, 282 (i.e. the two edges that extend laterally between the first and second lateral flanges 216, 218 and through the central portion 210), and as discussed herein may be curved with each portion of the curve including at least a vector component that faces in the lateral direction (i.e. perpendicular to the direction of motion of the truck that receives the adapter pad 200).

[00127] For example, at least a portion 374R, 376R of the outer edge 374, 376 may be formed with a continuous radius (R) with respect to a geometric center of the adapter pad, as annotated as “C” on Figure 16A. In some embodiments each outer edge 374, 376 may include two discontinuous curved edges 374R, 376R with a constant radius, with a center section between the two that may be straight or at a different curve(s) than the constant radius portions. In other embodiments, the constant radius portion may be continuous and extend from proximate to both opposite lateral edges 380, 382 upon the respective lateral flange, such as throughout the entirety of the respective lateral flange, or between the opposed lateral edges but mating with a portion 374z, 376z extending from the respective upturned portion 212, 214 to the edge 374, 376 with the radius geometry.

[00128] In some embodiments, the lateral edges 380, 382 and the longitudinal outer edges 374a, 376a, and any other edge of the elastomeric portion 360 may include an internally recessed contour 381, as best depicted in Figure 11A -11C. In some embodiments, the internally recessed contour 381 may be the same profile about the entire perimeter of the elastomeric member 360, while in other embodiments; the internally recessed contour 381 may be at differing profiles

depending upon the expected compression to be felt by that portion of the elastomeric member 360.

[00129] As can be appreciated, and discussed elsewhere herein, the elastomeric member 360 compresses and deforms under load and the elastomeric material presses radially outward proximate to the outer edges. The internally recessed contour 381 minimizes or eliminates the deformation of the elastomeric member 360 beyond the nominal outer edge of the member 360, which can in certain embodiments enhance the fatigue life of the adapter pad 200.

[00130] The internally recessed contour 381 may include a first portion 383 that generally extends downward from a lower surface of the top plate 220, a second portion 385 that generally extends upward from the upper surface of the bottom plate 240, and a transition 384 therebetween. In some embodiments, one or both of the first and second portions 383, 385 may be planar (along a straight portion of the elastomeric portion) or linear (along curved portions of the elastomeric portion) (collectively a linear portion) that extends from the respective surface of the top and bottom plates 220, 240 at angles α , and β .

[00131] In some embodiments, the first and second portions 383, 385 may extend at the same relative angle, while in other embodiments, the first and second portions 383, 385 may extend at differing relative angles. In some embodiments, the angle(s) may be about 30 degrees to the neighboring surface of the top or bottom plate 220, 240, such as an angle within the range of between about 15 and about 45 degrees, inclusive of all angles within this range. As shown in Figure 11B, the central elastomeric portion 362 can likewise include a similar internally recessed contour 381 extending around the outer edge of the central portion.

[00132] As best shown in Figures 11A, 11C, and 16B, one or both of the upturned portions 212, 214 may include a hollow portion(s) 372 within a cavity formed between the top and bottom plate 220, 240, which is a void where substantially no elastomeric material is provided, and can establish a discontinuity within the elastomeric member within the respective first and/or second upturned portions 212, 214. The hollow portions 372 may provide a complete separation between the elastomeric member 360 disposed within the central portion 210, and the elastomeric member disposed in the lateral flanges 216, 218. In certain

embodiments, the void may include a very small thickness layer of elastomeric material that contact each of the top and bottom plate 220, 240 through the transition, which can be a function of possible limitations of the tooling used in the molding process, but this thin layer (when existing) does not materially contribute to the performance of the adapter pad 200. Additionally, in some embodiments the hollow portion 372 can include small portions of elastomeric material that extend between the top and bottom plates 220, 240, but it is otherwise substantially hollow. In some embodiments, the width of the hollow portion 372 can be about 0.25 inches or in the range of about 0.1 inches to about 0.5 inches, or at least as wide as the maximum lateral and rotational motion on the adapter pad 200. In some embodiments, the hollow portion(s) 372 are configured to provide a lateral void between the top and bottom plate 220, 240 extending through the respective transition portion 212, 214, such that the respective inner surfaces of the top and bottom plates 220, 240 within the transition portion do not contact each other during lateral or rotation relative motion therebetween and/or in view of the lateral and/or rotational displacement during railcar operations with the adapter pad 200 disposed in position in the railcar truck system.

[00133] The hollow portion 372 can function to limit the bending stresses in the top and bottom plates 220, 240. The hollow portion 372 may be about 0.25 inches. At the about 0.25 inch motion range, the upturned regions of the top and bottom plate 220, 240 can engage and prevent further relative motion. This can put an upper limit on the elastomer strain in the lateral direction and the metal stress.

[00134] As will be discussed in more detail below, the elastomeric member 360 and particularly the outer elastomeric members 364, 366 can be configured in such a manner that the elastomer's rotational shear stresses, through a displacement of up to 41 milliradians, are no greater than the elastomer's lateral and longitudinal shear stresses through a displacement of up to 0.23 inches laterally and of up to 0.14 inches longitudinally. For example, the outer elastomeric members 364, 366 can be configured such that any point on curves 374R, 376R has less than or equal rotational shear displacement as the lateral or longitudinal shear displacements. And because shear strain is directly proportional to shear displacement, all points along the curve 374R, 376R can be subject to the same strain.

[00135] The elastomeric member 360 can be measured in a cross-sectional plane through about the center of the elastomeric material 360 centered between the inner surfaces of the top and bottom plates 220, 240. In embodiments where there are a plurality of elastomeric members each member can be measured separately and each member can be added together to determine the measurements of the entire elastomeric member 360. In some embodiments, the total shear width, or length in the lateral direction, of the elastomeric member 360 can be about 9.6 inches or in the range of about 6 inches to about 14 inches. Similarly, the total shear length, or length in the longitudinal direction, of the elastomeric member 360 can be about 6.9 inches or in the range of about 6 inches to about 10 inches. The composite shear perimeter, or perimeter of all portions of the elastomeric member can be about 51.70 inches or in the range of about 35 inches to about 75 inches. In some embodiments the total surface area of the elastomeric member 360 in the shear plane can be about 55.5 square inches or in the range of about 50 square inches to about 70 square inches. The total surface area of the elastomeric member 360 outside of the central portion can be about 15.5 square inches or in the range of about 5 square inches to about 30 square inches, or greater than 5 square inches. Thus, the surface area of the elastomeric member in the lateral flanges 216, 218 can be about 7.75 square inches each or in the range of about 2.5 square inches to about 15 square inches, or greater than 2.5 square inches.

[00136] As will be discussed in more detail below, the elastomer layers 364, 366 outside of the central area 210 can contribute to the overall stiffness of the adapter pad 200. For example in some embodiments, the elastomeric member 360 outside of the central area 210 can contribute about 15%, or in the range of about 5% to about 30%, of the total lateral and longitudinal stiffness of the adapter pad, and 33%, or in the range of about 15% to about 60%, of the rotational stiffness of the adapter pad 200.

[00137] As previously discussed, the elastomeric member 360 of the adapter pad 200 provides shear resistance during loading in the lateral, longitudinal, and rotational directions under a vertical load. This shear resistance is caused by relative movement between the top and bottom plates 220, 240 reacted through the elastomeric member 360. Simple shear strain is defined as d/t where $d =$

displacement of the elastomeric member and t = thickness of the elastomeric member. In some embodiments, the shear strain can reach values greater than 100% under maximum displacement conditions. For example, in some embodiments, lateral strain achieves 110% or 120% or 130%. In some embodiments shear strain does not exceed 105%, 110%, 115%, or 120%, or 130% under maximum displacement.

[00138] To reduce the stresses in the elastomeric member 360 under maximum shear displacement, it can be beneficial to provide normal stress, or compression, to the elastomeric member 360 during shear loading. In some embodiments, vertical loading of adapter pads is transferred through the pedestal roof 152 of the side frame, to the central area 210. Additionally, although the top and bottom plates 220, 240 can contact the vertical shoulders of the adapter, in some embodiments, the top and bottom plates 220, 240 are flexible and the vertical load on the central region 210 is not transferred equally to the lateral flanges 216, 218 and can create a non-uniform distribution of the vertical load to the elastomeric member 360. This can result in less compression of the elastomeric member 360 outside of the area under the pedestal roof 152. Various methods can be used that can increase the normal stress or compression in the elastomeric member 360 outside of the pedestal roof 152, for example, in the lateral flanges 216, 218.

[00139] In embodiments, the elastomeric member 360, outside the pedestal roof 152 area can be compressed greater than 0.020 inches, or greater than 7% of the static thickness of the elastomeric member 360. In certain embodiments, pre-compression of this magnitude allows for improved fatigue life of the elastomeric member 360. Additionally, in embodiments discussed herein about 10 percent to 30 percent of vertical force can be distributed to each of the adapter pad lateral flanges 216, 218 when a vertical force is applied to the central portion 210 of the adapter pad 200. And in embodiments discussed herein the reaction of the vertical load at the vertical shoulders 106 can provide a vertical force greater than 3000 pounds to precompress the elastomeric member.

[00140] In some embodiments, as shown primarily in Figure 18, compression of the elastomeric member 360 in the region outside the pedestal roof 152 (in the outer elastomeric members 364, 366), can be accomplished with an elastomeric member

360 having a non-uniform thickness along the length of the elastomeric member 360. For example, in some embodiments, the first and/or second outer portions 364, 366 may be formed with a thickness X while the central portion 362 may be formed with a different or smaller thickness Y. The geometry (such as the bends through the upturned portions 212, 214) of the top and bottom plates 220, 240 may be formed to accommodate the differences in thickness between X, Y allowing the elastomeric portions in the central and outer portions to contact the inner surfaces of the top and bottom plates 220, 240 as desired. In certain embodiments, the difference in thickness of the elastomeric member forming the first and/or second outer portions 364, 366 and the central portion 362 can assist in reducing the simple shear strains of the outer layers based upon in-plane forces applied to the adapter pad in the longitudinal, lateral, and rotational directions.

[00141] In some embodiments, as shown in Figure 18, one or both of the lateral flanges 216, 218 may be formed such that the elastomeric layers 364, 366 therewithin includes a thickness, X that is about 0.25 inches, such as within a range of 0.15 inches to 0.30 inches, inclusive of all thicknesses within the range. In this embodiment, the thickness Y of the elastomeric layer 360 in the central portion 362 may be about 0.20 inches, such as within a range of 0.15 inches to 0.25 inches, inclusive of all thicknesses within the range. The thicknesses of elastomeric layers discussed herein refer to the static thickness of the elastomeric layers or the thickness of the elastomeric layers without an external load on the elastomeric layer. One or both of the lateral flange portions 364, 366 and central portions 362 may have a different thickness, with the upper portions being thicker than the central portion this can achieve a desired effect, generally of increasing the load or compression of one or both of the lateral flange portions 364, 366, which due to the material properties of the elastomeric layer additionally increases its strength and durability based upon the contemplated loading during railcar operation.

[00142] In some embodiments, as shown in Figure 18, the adapter pad 200 can be formed by injection molding without bonding the top plate 220 (as shown in Figure 18), or alternatively the bottom plate 240, to the elastomeric member 360. After vulcanization of the elastomeric member 360, the top plate 220 (as shown in Figure 18), or alternatively the bottom plate 240, can be attached or bonded to the

elastomeric member. Because the outer elastomeric members 364, 366 have a greater thickness than the center elastomeric member 362, the lateral flanges 216, 218 must be compressed to attach or bond the top plate 220 (as shown in Figure 24), or alternatively the bottom plate 240, to the elastomeric member. In some embodiments, the center elastomeric member 362 will react the compression load keeping the wings in a state of compressive strain.

[00143] In some embodiments, as shown in Figures 19-23, compression of the elastomeric member 360 in the region outside the pedestal roof 152, can be accomplished by forming the elastomeric member 360 with gaps in the central portion 362. In some embodiments, for example, the central portion 362 includes one or in other embodiments a plurality of elongate gaps 868 that partially or completely separate the central portion 362 into multiple portions 862a, 862b, 862c, 862d, 862e as shown in Figure 19. The one or plurality (for convenience referred to as “a plurality hereafter, although a single gap is contemplated as well) of gaps 868 collectively establish a plurality of discontinuities within the central portion 362. When the adapter pad 200 is assembled between the side frame and the bearing adapter 199, the central portion 210 of the adapter pad 200 can carry significant compressive force, which is felt by the relatively compressible elastomeric portion 360 (when compared to the top and bottom plates 220, 240), which tends to deform and expand the elastomeric member 360 laterally and longitudinally (based upon the material being vertically compressed). The presence of the plurality of gaps 868 can provide a dedicated volume for the lateral expansion (in embodiments where the plurality of gaps 868 each extend longitudinally). Likewise, in embodiments where the plurality of gaps also or instead extend laterally, the presence of the gaps 868 provides a dedicated volume for longitudinal expansion.

[00144] As best shown in Figure 19, in some embodiments, the plurality of gaps 868 each extend longitudinally between the opposite lateral edges of the 880, 882 of the elastomeric portion 860, and extend in parallel with each other. In some embodiments, the plurality of gaps 868 each communicate through both of the first and second longitudinal edges 880, 882 when the adapter pad 800 is in an unloaded configuration. Under load, all, or a portion of the plurality of gaps 868 may be deformed (as discussed above) such that only a portion of the respective gap 868

communicates through the respective longitudinal edge 880, 882, or in some embodiments, substantially the entire gap 868 may be closed intersecting the longitudinal edge 880, 882, such that no visual opening may be perceived into the gap 868 (which is visible from the respective edge 880, 882 in an unloaded configuration).

[00145] In some embodiments as shown in Figures 19 and 22, each of the plurality of gaps 868 may be formed with a uniform cross-section along its length, and either all of the plurality of gaps 868 may be formed with the same cross-section (in an unloaded state), or each of the plurality of gaps 868 may be defined with a constant cross-section along its length.

[00146] Figures 20A-20C depict various types of cross-sections for the plurality of gaps 868. Generally, the plurality of gaps 868 are contemplated to include one or more curved or planar sides, and each of the plurality of gaps 868 may include a combination of curved and planar features. For example, the plurality of gaps 868a that have a round cross-section, or include curved sides. In some embodiments, the opposite sides (that extend between the top and bottom plates 220, 240) may be of the same size and geometry, while as depicted in Figure 20a, one side may have a different shape or size than the opposite side (see 866' and 868'' in Figure 20a).

[00147] Figure 20B depicts alternately shaped gaps 868c that are generally oval shaped. Figure 20C depicts alternatively shaped gaps 868d that are shaped as a truncated diamond with two opposite planar sides (with the truncated portion contacting the bottom plate 240). Figures 21A-21C provide schematic representations of the potential shape of the various plurality of gaps 868 with a load (F) applied to the adapter pad 200.

[00148] In some embodiments, and as depicted in Figure 22, the plurality of gaps 868e extend only a partial longitudinal distance through the elastomeric member 860 and as depicted do not reach the longitudinal edges 880, 882, while other placement (such as extending to one of the two longitudinal edges 880, 882, or with ends closer to one of the two longitudinal edges 880, 882 is contemplated). The gaps 868d in this embodiment may be sized and shaped based upon the various sizes and shapes contemplated above.

[00149] In other embodiments depicted in Figure 23, the plurality of gaps 868f may extend for a thickness that is less than a total distance between the top plate 220 and the bottom plate 240, with a portion of the elastomeric member being vertically disposed with respect to one or more of the plurality of gaps 868f and contacting one or both of the top and bottom plates 220, 240. As depicted in Figure 23, the gap 868f contacts the lower surface of the top plate 220, but does not contact the bottom plate 240.

[00150] As best shown in Figure 23, the inner surfaces of the top or bottom plate 220, 240 may include a recessed portion 825a located along the portions of the top or bottom plate 220, 240 that communicate with the plurality of gaps 868. The recessed portions 825a may be provided to index the tooling (such as a core or other types of molding equipment known in the art) for the elastomeric portion to establish the gaps 868 with respect to the top or bottom plate 220, 240. The recessed portion 825a may additionally provide space for expansion / deformation of the elastomeric member 860 under load, to minimize the size of the gaps 868 yet still provide the benefits of the expansion / deformation space as needed.

[00151] Additionally, other methods that can increase the compression of the elastomeric member 360 in the lateral flanges 216, 218 exist. For example, as shown in Figure 24, in some embodiments, the lateral flanges 216, 218 can be compressed together after inserting the elastomeric members 364, 366 between the top and bottom plates 220, 240. Compressing the top and bottom plates 220, 240 together can induce plastic deformation of the steel. The plastic deformation of the top and bottom plates 220, 240 can induce a normal stress in the outer elastomer layers 364, 366 and can increase the compression. Compression of the top and bottom plates 220, 240 can be accomplished using a die or other suitable equipment. As used herein the term inserting can encompass a number of processes including inserting elastomer using an injection molding process or a casting process, and other known techniques.

[00152] In still other embodiments, for example, compression in the lateral flanges 216, 218 can be induced by manufacturing the lateral flanges 216, 218 of the top and bottom plates 220, 240 to angle towards each other and then mold the flanges to a generally parallel position. For example, the top plate 220 can be

manufactured such that the lateral flanges 232, 234 are angled outward and downward and the bottom plate 240 lateral flanges 252, 254 are angled outward and upward prior to assembling the adapter pad 200. Thus, when originally manufactured, the lateral flanges of the top and bottom plates are not parallel and instead are angled towards each other. The plates 220, 240 are then assembled with the elastomeric section 360 and the lateral flanges 232, 234, 252, 254 are forced to elastically bend to a generally parallel alignment with each other. In some embodiments, this step can be accomplished, using an injection molding machine wherein the elastic member 360 is injected into the mold. Once the adapter pad is cured, there can be an elastic strain in the laterally projecting flanges that applies a normal load to the outer elastomer layers 364, 366 that can create compressive strain.

[00153] In still other embodiments, as shown in Figures 25 and 26, compression of the elastomeric member 360 in the lateral flanges 216, 218 can be increased by using compression shims within or under the lateral projecting flanges 216, 218. Compression shims can be used herein such that reaction of the vertical load at the vertical shoulders 106 provides a vertical force greater than 3000 pounds such that about 10 percent to 30 percent of vertical force is distributed to each of the adapter pad lateral flanges 216, 218 when a vertical force is applied to the central portion 210 of the adapter pad 200. Compression shims can in some embodiments force more of the vertical load of the car to be distributed from the center elastomer layer 360 to the outer elastomer layers 364, 366. As shown in Figure 25, a first adapter compression shim 290 can be disposed between an upper surface of the vertical shoulder of the roller bearing adapter 199 and the outer surface 244 of the first lateral flange 216 of the bottom plate 240. Similarly, though not shown in a Figure, a second adapter compression shim 290 can be similarly placed in relation to the second lateral flange 218 (not shown). The adapter compression shims 290 can be about 0.05 inches thick or within the range of about 0.06 inches to about 0.18 inches. Compression shims as discussed herein can have any number of different shapes and configurations to provide the necessary loads to compress the outer elastomer. For example compression shims can be rectangular, square, trapezoidal, pyramidal, can have a hollow cross-section, and can be a plurality of compression

shims. Further, compression shims as discussed herein can be integrally formed with the adapter pad during the molding process, can be integrally formed with the roller bearing adapter, or can be added to the roller bearing adapter system after the molding process.

[00154] As shown, for example, in Figures 25A-I, compression shims as discussed herein can have a number of different shapes and configurations. As shown in Figure 25A, the compression shims 290 can be substantially rectangular and can have a width equal to or less than the width of the outer surface 244 of the lateral flange 252, 254 of the bottom plate 240. Similarly, the compression shims 290 as shown in Figure 25A can have a length that is less than or equal to the length of the outer surface 244 of the lateral flange 252, 254 of the bottom plate 240. The compression shims 290 can have a constant or variable thickness. As shown in Figures 25B, 25C, and 25D the compression shims 290 can have a curved, trapezoidal, or triangular cross-section shape. Additionally, as shown in Figures 25E and 25D the compression shims 290 can have a raised center portion 295 that can be generally curved as shown in Figure 25E or generally triangular as shown in Figure 25F, or any other suitable shape. As shown in Figure 25G, the compression shims 290 can include a hollow portion 296. Additionally, as shown in Figures 25H, and 25I the compression shims 290 can comprise a plurality of compression shims.

[00155] As shown in Figure 26, the adapter pad 200 can also include compression shims between the elastomeric member 360 and either the top or bottom plate 220, 240. As shown in Figure 26, the adapter pad 200 can include a first upper adapter pad compression shim 291 disposed in the first lateral flange 216 between the top plate 220 and the first outer elastomeric member 364. Similarly, although not shown in a Figure, a second upper adapter pad compression shim 291 can be disposed in the second lateral flange 218 between the top plate 220 and the second outer elastomeric member 366. Additionally, although not shown in a Figure, similar first and second lower adapter pad compression shims can be disposed in the first and second lateral flanges 216, 218 between the elastomeric member 360 and the bottom plate 240. The upper and lower adapter pad compression shims 291 can be about 0.05 inches thick or within the range of about 0.06 inches to about 0.18 inches.

[00156] To apply the upper or lower adapter pad compression shims 291, shown in Figure 26, the adapter pad 200 can be formed through injection molding without adhesive applied to one of the top or bottom plates 220, 240 in the laterally projecting flanges 216, 218. This can prevent the outer elastomer layer 364, 366 from adhering to the top or bottom plate 220, 240. After vulcanization, the upper or lower adapter pad compression shims 291 can be inserted between the outer elastomer 364, 366 and the top or bottom plate 220, 240. As discussed above, this can compress the elastomeric member 360 in the laterally projecting flanges 216, 218, increasing the normal stress.

[00157] As discussed above, it has been determined through testing that the performance of the adapter pad system 198 is a function of the stiffness of the adapter pad 200. More specifically in certain embodiments, it has been determined that adapter pad performance, including design life, can be improved by increasing the stiffness of the adapter pad system 198 (measured in pounds of force per inch of deformation).

[00158] Physical measurement of the pad stiffness can be determined by cycling the adapter pad 200 in three principal directions: laterally, longitudinally, and rotationally; while withstanding a constant vertical load on the pad, typically of 35,000 pounds. The force to displace the pad relative to the distance the pad displaces is recorded throughout the measurement test. The data from the test can then be collected and plotted on force vs. displacement plots, an example of which is shown in Figure 27. The stiffness, damping, and hysteresis for each direction of motion may then be determined using the following methods: Stiffness of the pad 200 can be determined by determining the upper and lower bounds which capture the linear portion of the force vs. displacement curve, then calculating the slope of the best fit line between the upper and lower bounds, for the upper and lower portion of the curve. The stiffness is then determined by averaging the upper and lower slopes. As discussed above, longitudinal stiffness is measured in the rail or track direction, lateral stiffness is measured perpendicular to the track direction, and rotational stiffness is measured as resisting rotation of the adapter about a vertical axis at the longitudinal and lateral centerline of the pedestal opening (annotated as "C" on Figure 16A). The hysteresis is determined, an example of which is shown in Figure

27, by measuring the upper and lower y-intercepts and subtracting the lower y-intercept from the upper y-intercept. The damping is determined, as shown in Figure 27 by measuring the area within the force displacement loop. The amount of pad damping over the given displacement range is directly proportional to the area contained within the loop at the desired frequency.

[00159] The target damping value for embodiments disclosed herein is 0.10 to 0.30 $\tan \delta$ with a rubber / elastomeric material durometer target of 60A to 80A. $\tan \delta$ is a measure of the material damping when subjected to cyclic loads, defined as the ratio of the out-of-phase load (90 degrees on a sinusoidal load) to the in-phase load (0 degrees). Typical values for elastomers can be .04 to .35.

[00160] A more direct measure of the energy absorption for an adapter pad is the area of the hysteresis loop per cycle. For the embodiments described herein, the hysteretic energy absorption can be estimated by $\pi 3G \tan \delta \epsilon^2$ where G is the shear modulus of ~ 360 psi, $\tan \delta \sim 0.3$ and ϵ the strain during hunting at $\sim 100\% = 1$. At 4 Hz, the energy absorption would be about 4,070 in-lb./sec. A reasonable range may be +/- 25%.

[00161] As discussed herein, certain embodiments include elastomeric member 360 (portions 364, and 366) in shear, outside of the area beneath the pedestal roof 152. In such embodiments, there can be more elastomeric material than can be used in shear than in a typical adapter pad. This can allow the adapter pad 200 to achieve increased stiffness without decreasing the shear thickness, or increasing elastomer durometer. Decreasing the shear thickness and/or increasing the elastomer durometer which can increase the strain and reduce the useful life of the pad. Thus, the adapter pad 200 can increase the stiffness of the adapter pad system 198 which can improve railcar overall performance while increasing the useful life of the adapter pad 200. The outer elastomer layers 364, 366 can increase the rotational stiffness of the adapter pad 200 by providing additional elastomer at a distance farther from the axis of rotation. In some embodiments, for example, the outer elastomeric layers 364, 366 can account for about 15% or about 10% to about 20%, or greater than 10% of the total lateral and longitudinal stiffness of the adapter pad 200, and can account for about 33% or about 25% to about 40%, or greater than 25% of the rotational stiffness of the adapter pad 200.

[00162] Embodiments disclosed herein can have high lateral and longitudinal stiffness, without having high force vs. displacement hysteresis. Hysteresis is proportional to energy dissipated through the displacement cycles, and can be lost in the form of heat or noise. Generally, the higher the hysteresis, the greater the temperature rise in the adapter pad 200, and the lower the fatigue life. Embodiments disclosed herein attain high stiffness of the adapter pad, while improving fatigue life by minimizing hysteresis and allowing the pad to displace to maximum magnitudes set by the AAR: 41 milliradians rotationally, 0.23 inches laterally, and 0.14 inches longitudinally.

[00163] Embodiments disclosed herein may require increasing amounts of force to displace the top plate 220 relative to the bottom plate 240 with higher magnitudes. The thickness, length, and amount of elastomeric material in the hollow section 372 can be adjusted to change the slope, and shape of the force vs. displacement graphs. In some embodiments, it is possible to have different stiffness properties for the elastomeric material of the pad located adjacent to the upturned adapter wings compared to the properties of the elastomeric material located in the central area of the adapter pad.

[00164] Using the above described test methods, exemplary measurements and testing results of embodiments disclosed herein are shown below in Table 2. It is understood that these embodiments are examples, and that other structural embodiments with other testing results can exist.

Table 2

	Embodiments Described Herein
Elastomer Normal Area (in²)	55.5 in ² or about 50 in ² to about 70 in ²
Elastomer Normal Area Outside of Pedestal Roof Contact (in²)	15.5 in ² or about 5 in ² to about 30 in ²
Pad Elastomer Shear Width (Lateral Length) (in)	9.6 in ² or about 6 in ² to about 14 in ²

Pad Elastomer Shear Length (Longitudinal Length) (in)	6.9 in ² or about 6 in ² to about 10 in ²
Lateral Stiffness (tested at 3hz cycling frequency and 35 kip vertical load)	60 kips/in or about 45 kips/in to about 80 kips/in or at least 45 kips/in
Longitudinal Stiffness (tested at 3hz cycling frequency and 35 kip vertical load)	64 kips/in or about 45 kips/in to about 80 kips/in or at least 45 kips/in
Rotational Stiffness (tested at 3hz cycling frequency and 35 kip vertical load)	670 kip*in/mRad or about 250 kip*in/mRad to about 840 kip*in/mRad or at least 250 kip*in/mRad
Vertical Stiffness	at least 5,000 kips/in
Lateral Hysteresis (tested at 3hz cycling frequency and 35 kip vertical load)	5000 lbs. or about 3750 lbs. to about 6250 lbs. or less than 6000 lbs.
Longitudinal Hysteresis (tested at 3hz cycling frequency and 35 kip vertical load)	500 lbs. or about 375 lbs. to about 1500 lbs. or less than 1500 lbs.
Rotational Hysteresis (tested at 3hz cycling frequency and 35 kip vertical load)	12000 lbs.*in or about 9000 lbs.*in to about 16000 lbs.*in or less than 16000 lbs.*in
Center Elastomer Layer Shear Perimeter	25.5 in. or about 20 in. to about 30 in.
Outer Elastomer Layer Shear Perimeter	13.1 in. each or about 8 to 18 in. each
Composite Elastomer Layer Shear Perimeter	51.7 in. or about 35 in. to 75 in.

Center Elastomer Layer Shape Factor	8.3 or about 6 to 10
Outer Elastomer Layer Shape Factor	1.6 each or about .5 to 3 each
Composite Shape Factor	4.5 or about 2.5 to about 7

[00165] In one example an adapter pad system configured to be disposed between a wheelset roller bearing and side frame pedestal roof of a railcar truck is disclosed. The adapter pad system can include a roller bearing adapter having first and second vertical shoulders that project upward from a top surface of the adapter. The adapter pad system can also include an adapter pad configured to interface with the roller bearing adapter with a top plate having inner and outer surfaces, a central portion, first and second upturned regions projecting upward from opposite edges of the central portion, a first lateral flange projecting outward from the first upturned region, and a second lateral flange projecting outward from the second upturned region; a bottom plate having inner and outer surfaces, a central portion, first and second upturned regions projecting upward from opposite edges of the central portion, a first lateral flange projecting outward from the first upturned region, and a second lateral flange projecting outward from the second upturned region. The first and second laterally projecting flanges of the top plate and the bottom plate of the adapter pad system can be disposed above the vertical shoulders of the roller bearing adapter.

[00166] The roller bearing adapter of the adapter pad system can be cast or forged. The adapter pad can be engaged with the side frame and engaged with the roller bearing adapter. The top plate of the adapter pad can be engaged with the side frame such that movement between the top plate and the side frame is restricted. The bottom plate of the adapter pad can be engaged with the roller bearing adapter such that movement between the bottom plate and the roller bearing adapter is restricted. The roller bearing adapter can include longitudinal stops configured to restrict longitudinal movement of the bottom plate with respect to the roller bearing adapter. The vertical shoulders can be configured to restrict lateral movement of the bottom plate with respect to the roller bearing adapter. The roller

bearing adapter top surface can include a crowned surface. The longitudinal stops and vertical shoulders can be configured to restrict rotational movement of the bottom plate with respect to the roller bearing adapter. The roller bearing adapter can be symmetrical about a lateral centerline. The roller bearing adapter can be symmetrical about a longitudinal centerline. The top plate of the roller bearing adapter can be continuous. The bottom plate of the roller bearing adapter can be continuous.

[00167] The adapter pad system can include an elastomeric member disposed between the inner surfaces of the top plate and the bottom plate. The elastomeric member disposed between the top plate and the bottom plate can be a plurality of elastomeric members. The plurality of elastomeric members can include a first outer elastomeric member disposed between the first lateral flanges of the top and bottom plates, a second outer elastomeric member disposed between the second lateral flanges of the top and bottom plates, and a central elastomeric member disposed between the central portion of the top and bottom plates. A first hollow portion can be disposed between the central elastomeric member and the first outer elastomeric member and a second hollow portion can be disposed between the central elastomeric member and the second outer elastomeric member. The first and second hollow portions can be about 0.25 inches wide. The first and second hollow portions can be configured to limit bending stresses in the top and bottom plates. The outer elastomeric members can be in compression. The thickness of the outer elastomeric members can be compressed at least 0.020 inches from a static state. The thickness of the outer elastomeric members can be compressed at least 7% from a static state. The first outer elastomeric member, second outer elastomeric member, and central elastomeric member can each be substantially planar and each can be substantially horizontal when the adapter pad is disposed below a side frame pedestal roof of a railcar truck. The elastomeric material can be positioned normal to the direction of lateral displacement to increase compression stiffness. The elastomeric material can be positioned normal to the direction of longitudinal displacement to increase compression stiffness. The elastomeric material can be positioned normal to the direction of rotational displacement to increase compression

stiffness. The elastomeric material can be positioned normal to the direction of vertical displacement to increase compression stiffness.

[00168] The surface area of the first outer elastomeric member at a cross-sectional plane through the first outer elastomeric member centered between the inner surfaces the top and bottom plates can be greater than 2.5 square inches. The surface area of the second outer elastomeric member at a cross-sectional plane through second outer elastomeric member in a plane centered between the inner surfaces of the top and bottom plates can be greater than 2.5 square inches. The combined surface area of the first and second outer elastomeric members at cross-sectional planes through the first and second outer elastomeric members in planes centered between the inner surfaces of the top and bottom plates can be greater than 5 square inches. The combined surface area of the first and second outer elastomeric members at cross-sectional planes through the first and second outer elastomeric members in planes centered between the inner surfaces of the top and bottom plates can be at least 10 percent of the surface area of the central elastomeric member at a cross-section plane through the center of the central elastomeric member in a centered between the inner surfaces of the top and bottom plates.

[00169] The central elastomeric member can define a plurality of gaps that establish a plurality of discontinuities within the elastomeric member disposed between the central portion of the top plate and the central portion of the bottom plate. The plurality of gaps can be a thickness less than a total distance between the top plate and the bottom plate, with a portion of the elastomeric member being vertically disposed with respect to the one or more of the plurality of gaps and contacting one or both of the top and bottom plates.

[00170] The central elastomeric member can define an outer edge, wherein one or more portions of the outer edge is curved from a top view. At least a portion of the outer edge of the central elastomeric portion can define an internally recessed contour. The first and second outer elastomeric members can define an outer edge, wherein one or more portions of the outer edge is curved from a top view. One or more portions of outer edges of elastomeric members can include a continuous

radius measured from a center point of the central portion of the top plate. Any edge of the elastomeric member can define an internally recessed contour.

[00171] One or both of the first and second outer elastomeric members can define an outer edge, wherein one or both of the first and second lateral flanges of the top and bottom plates extend outward past at least a portion of the outer edge within the respective first and second lateral flanges.

[00172] The adapter pad can include an elastomeric support disposed between the outer surfaces of the first and second lateral flanges of the bottom plate and the vertical shoulders of the roller bearing adapter.

[00173] At least a portion of an outer edge of the elastomeric members can define an internally recessed contour. The internally recessed contour can be defined by a first linear portion that extends from proximate to the inner surface of the top plate and a second linear portion that extends from proximate to the inner surface of the bottom plate. The first and second linear portions can be connected with a transition as it extends between the first and second linear portions. The first and second linear portions can each extend from the neighboring respective top or bottom plate at an angle within the range of about 25 degrees to about 35 degrees to a plane through the surface of the respective top or bottom plate from which the respective linear portion extends.

[00174] The first and second outer elastomeric members can be the same or greater thickness than the central elastomeric member. The thickness of the first and second outer elastomeric members can be within the range of about 0.15 inches to about 0.30 inches. The thickness of the central elastomeric member can be within the range of about 0.15 inches to about 0.25 inches. The thickness of the adapter pad can be within the range of about 0.4 inches to about 0.8 inches.

[00175] The adapter pad system can also include an elastomeric layer disposed above an outer surface of the top plate and/or can include an elastomeric layer disposed below an outer surface of the bottom plate. The elastomeric layer can cover all or portions of the outer surface of the adapter pad. The top and bottom plates of the adapter pad can be of non-uniform thickness. The top and bottom plates can be of uniform thickness. The top plate can have a non-uniform thickness.

The top plate can have a uniform thickness. The bottom plate can have a non-uniform thickness. The bottom plate can have a uniform thickness.

[00176] The adapter pad system can be configured to return to a neutral or central position within the side frame pedestal after removal of a load placed thereon.

[00177] The first and second lateral flanges of the top plate can include a planar outer surface that can be parallel to the outer surface of the central portion of the top plate.

[00178] The inner surfaces of each of the first and second upturned regions of the first and second plates of the adapter pad can include a planar portion. The inner surfaces of each of the first and second upturned regions of the first and second plates of the adapter pad can include a curved portion. The first and second upturned regions of the first and second plates of the adapter pad can include at least a portion that extends at an obtuse angle to a plane through the outer surface of the central portion of the top plate.

[00179] The first and second lateral flanges of the top plate of the adapter pad can include exposed outer surfaces when the adapter pad contacts a side frame pedestal. The first and second lateral flanges can contact air outside of the envelope of the side frame at the pedestal opening. The first and second lateral flanges can be configured to reduce heat of the adapter pad. The first and second lateral flanges can be configured to reduce heat of the adapter pad system.

[00180] The adapter pad can include a lateral length of the central portion that can be equal to the distance between the sidewalls of at the pedestal roof surface. The lateral length of the central portion can be about 0.125 inches greater than the length between the side walls of the side frame at the pedestal roof surface. The overall lateral length of the top plate can be at least 7.5 inches.

[00181] The adapter pad system can also include a first lateral adapter grip disposed between an inside surface of the first vertical shoulder of the roller bearing adapter and the first upturned region of the bottom plate; and a second lateral adapter grip disposed between an inside surface of the second vertical shoulder of the roller bearing adapter and the second upturned region of the bottom plate. The first and second lateral adapter grips can be formed of an elastomeric material. The

first and second lateral adapter grips can be configured to limit sliding or relative movement between the roller bearing adapter and the outer surface of the bottom plate of the adapter pad. The first and second lateral adapter grips can be configured to center the bottom plate of the adapter pad on the roller bearing adapter.

[00182] The adapter pad system can also include a first lateral side frame grip disposed on the outer surface of the first upturned region of the top plate; and a second lateral side frame grip disposed on the outer surface of the second upturned region of the top plate. The first lateral side frame grip can be disposed between the outer surface of the first lateral flange of the top plate and a side frame pedestal, and the second lateral side frame grip can be disposed between the outer surface of the second lateral flange of the top plate and a side frame pedestal. The first and second lateral side frame grips can be formed of an elastomeric material. The first and second lateral side frame grips can be configured to limit sliding or relative movement between an outer surface of the top plate and the side frame immediately above the pedestal area.

[00183] In some examples, the adapter pad system can be configured to restrict the elastomer temperatures below the degradation temperature of the specific elastomeric and/or adhesive material used in pad construction. The adapter pad system can also be configured to reduce melting of the elastomeric member.

[00184] The adapter pad system can include a first adapter compression shim disposed between an upper surface of the first vertical shoulder of the roller bearing adapter and the outer surface of the first lateral flange of the bottom plate. The adapter pad system can also include a second adapter compression shim is disposed between an upper surface of the second vertical shoulder of the roller bearing adapter and the outer surface of the second lateral flange of the bottom plate. The thickness of the first and second adapter compression shims can be within the range of about 0.06 inches to about 0.18inches.

[00185] The adapter pad can include a lower first adapter pad compression shim disposed between the elastomeric member and the first lateral flange of the bottom plate. The adapter pad can also include a second lower adapter pad compression shim is disposed between the elastomeric member and the second

lateral flange of the bottom plate. The thickness of the first and second lower adapter pad compression shims can be within the range of about 0.06 inches to about 0.18 inches.

[00186] The adapter pad can include a first upper adapter pad compression shim disposed between the first lateral flange of the top plate and the first outer elastomeric member. The adapter pad can also include a second upper adapter pad compression shim is disposed between the second lateral flange of the top plate and the second outer elastomeric member. The thickness of the first and second upper adapter pad compression shims can be within the range of about 0.06 inches to about 0.18 inches.

[00187] The compression shims can be configured to provide at least 3000 pounds of vertical compressive load into the outer elastomeric members when a vertical load of 35,000 pounds is applied to the central portions of the adapter pad. The compression shims can be rectangular. The compression shims can have a rectangular cross-section shape, a curved cross-sectional shape, a triangular cross-sectional shape, or a trapezoidal cross-sectional shape. The compression shims can include a raised portion. The compression shims can include a hollow portion. The compression shims can comprise a plurality of compression shims.

[00188] The lateral flanges of the adapter pad can be vertically supported by the vertical shoulders of the roller bearing adapter. About 10 percent to 30 percent of vertical force can be distributed to each of the adapter pad lateral flanges when a vertical force is applied to the central portions of the adapter pad. The reaction of the vertical load at the vertical shoulders can provide a vertical force of at least 3000 pounds to precompress the elastomeric member.

[00189] The combined top plate, bottom plate, and elastomeric member of the adapter can pad provide a longitudinal stiffness that can be at least 45,000 pounds per inch through a longitudinal displacement of the top plate relative to the bottom plate of up to 0.139 inches from a central position, when a vertical load of 35,000 pounds is applied to the central portions of the adapter pad. The longitudinal hysteresis of the adapter pad system can be less than about 1500 lbs.

[00190] The combined top plate, bottom plate, and elastomeric member of the adapter pad can provide a lateral stiffness that can be at least 45,000 pounds per

inch through a lateral displacement of the top plate relative to the bottom plate of up to 0.234 inches from a central position, when a vertical load of 35,000 pounds is applied to the central portions of the adapter pad. The lateral displacement hysteresis of the adapter pad system can be less than about 6,000 lbs.

[00191] The top plate, bottom plate, and elastomeric member of the adapter pad can provide a rotational stiffness that can be at least 250,000 pound * inches per radian of rotation through a rotational displacement of the top plate relative to the bottom plate of up to 41 milliradians from a central position when a vertical load of 35,000 pounds is applied to the central portions of the adapter pad. The twist hysteresis can be less than about 16,000 lbs.*in.

[00192] The top plate, bottom plate, and elastomeric member of the adapter pad can provide a vertical stiffness that can be at least 5,000,000 pounds per inch through a vertical displacement of 0.05 inches. Vertical displacement can be non-linear and can range from 5,000,000 pounds per inch to 30,000,000 pounds per inch depending on variations in durometer, thickness tolerances, and non-linearity of the compression stiffness.

[00193] The combined top plate, bottom plate, and elastomeric member of the adapter pad can provide a lateral stiffness that is within about ten percent of a longitudinal stiffness when a vertical load is applied to the central portions of the adapter pad.

[00194] The combined top plate, bottom plate, and elastomeric member of the adapter pad can provide a lateral strain in the elastomeric member that is substantially similar throughout the elastomeric member when a vertical load is applied to the central portions of the adapter pad.

[00195] The combined top plate, bottom plate, and elastomeric member of the adapter pad can provide a longitudinal strain in the elastomeric member that is substantially similar throughout the elastomeric member when a vertical load is applied to the central portions of the adapter pad.

[00196] The combined top plate, bottom plate, and elastomeric member of the adapter pad can provide a rotational strain in the elastomeric member that can be substantially similar throughout the elastomeric member when a vertical load is applied to the central portions of the adapter pad.

[00197] The combined top plate, bottom plate, and elastomeric member of the adapter pad can provide a rotational strain that is less than or equal to the lateral strain at any point in the elastomeric member when a vertical load is applied to the central portions of the adapter pad.

[00198] The combined top plate, bottom plate, and elastomeric member of the adapter pad can provide shear strain that does not exceed 120% under maximum displacement

[00199] The thickness of the central portion of the bottom plate of the adapter pad can be non-uniform. The thickness of the central portion of the bottom plate can be greater at the lateral edges than at the center of the central portion.

[00200] The thickness of the elastomeric member disposed between the central portions of the top and bottom plate can be substantially uniform.

[00201] In another example a method for forming an adapter pad can include providing a top plate having a central portion, first and second upturned regions projecting upward from opposite edges of the central portion, a first lateral flange projecting outward from the first upturned lateral portion, and a second lateral flange projecting outward from the second upturned lateral portion; providing a bottom plate having a central portion, first and second upturned regions projecting upward from opposite edges of the central portion, a first lateral flange projecting outward from the first upturned lateral portion, and a second lateral flange projecting outward from the second upturned lateral portion; inserting an elastomeric member between the top plate and the bottom plate wherein a first outer elastomeric member is disposed between the first lateral flanges, a second outer elastomeric member is disposed between the second lateral flanges, and a central elastomeric member is disposed between the central portions; and compressing the first lateral flange of the top plate and the first lateral flange of the bottom plate towards each other; and compressing the second lateral flange of the top plate and the second lateral flange of the bottom plate towards each other.

[00202] The compressing steps can create deformation of the first and second lateral flanges after the molding operation is complete. This deformation can result in preloading of the outer elastomeric members. The compressing steps can apply greater than 3000 pounds force of compression in the outer elastomer members.

The compressing steps can compress the outer elastomeric member at least 0.02 inches of a static thickness of the outer elastomeric members. The compressing steps compress the outer elastomeric member greater than 7 percent of a static thickness of the outer elastomeric members.

[00203] In another example a method for forming an adapter pad can include providing a top plate having a central portion, first and second upturned regions projecting upward from opposite edges of the central portion, a first lateral flange projecting outward and downward from the first upturned lateral portion, and a second lateral flange projecting outward and projecting downward from the second upturned lateral portion; providing a bottom plate having a central portion, first and second upturned regions projecting upward from opposite edges of the central portion, a first lateral flange projecting outward and upward from the first upturned lateral portion, and a second lateral flange projecting outward and projecting upward from the second upturned lateral portion; inserting an elastomeric member between the top plate and the bottom plate; and compressing the top plate and the bottom plate such that the lateral portions of the top and bottom plates are substantially parallel.

[00204] The compressing steps can compress the outer elastomeric member at least 0.02 inches of a static thickness of the outer elastomeric members. The compressing steps can compress the outer elastomeric member greater than 7 percent of a static thickness of the outer elastomeric members.

[00205] In another example a method for forming an adapter pad can include providing a top plate having a central portion, first and second upturned regions projecting upward from opposite edges of the central portion, a first lateral flange projecting outward from the first upturned lateral portion, and a second lateral flange projecting outward from the second upturned lateral portion; providing a bottom plate having a central portion, first and second upturned regions projecting upward from opposite edges of the central portion, a first lateral flange projecting outward from the first upturned lateral portion, and a second lateral flange projecting outward from the second upturned lateral portion; inserting a first outer elastomeric member between the first lateral flange of the top plate and the first lateral flange of the bottom plate; and inserting a second outer elastomeric member between the second lateral flange

of the top plate and the second lateral flange of the bottom plate; and inserting a central elastomeric member between the central region of the top plate and the central region of the bottom plate

[00206] The thickness of the central elastomeric member can be less than or equal to the thickness of the first and second outer elastomeric members.

[00207] In another example a method for forming an adapter pad can include providing a top plate having a central portion, first and second upturned regions projecting upward from opposite edges of the central portion, a first lateral flange projecting outward from the first upturned lateral portion, and a second lateral flange projecting outward from the second upturned lateral portion; providing a bottom plate having a central portion, first and second upturned regions projecting upward from opposite edges of the central portion, a first lateral flange projecting outward from the first upturned lateral portion, and a second lateral flange projecting outward from the second upturned lateral portion; inserting a first outer elastomeric member between the first lateral flange of the top plate and the first lateral flange of the bottom plate; and inserting a second outer elastomeric member between the second lateral flange of the top plate and the second lateral flange of the bottom plate; and inserting a central elastomeric member between the central region of the top plate and the central region of the bottom plate; compressing the first and second lateral flanges of the top plate and the bottom plate together; and bonding the top plate to the first outer elastomeric member, the second outer elastomeric member, and the central elastomeric member.

[00208] The thickness of the central elastomeric member can be less than the thickness of the first and second outer elastomeric members.

[00209] The compressing steps can compress the outer elastomeric member at least 0.02 inches of a static thickness of the outer elastomeric members. The compressing steps compress the outer elastomeric member greater than 7 percent of a static thickness of the outer elastomeric members.

[00210] In another example, an adapter pad system for use between a railcar side frame pedestal and a rail car axle roller bearing adapter is disclosed. The side frame pedestal can define a first outer side, an opposite second outer side, and a pedestal roof located and extending between the first outer side and the second

outer side. The adapter pad system can include a bearing adapter defining a bottom surface and a top surface, the bottom surface mounted to the railcar axle roller bearing, the top surface defining opposing first and second vertical shoulders that project upwardly from the top surface, on either side of the side frame just above the pedestal roof. The adapter pad system can include an adapter pad configured to interface with the bearing adapter including a top plate having inner and outer surfaces, a central portion, first and second upturned regions projecting upwardly from opposite edges of the central portion, a first lateral flange projecting outwardly from the first upturned region, and a second lateral flange projecting outwardly from the second upturned region; and a bottom plate having inner and outer surfaces, a central portion, first and second upturned regions projecting upwardly from opposite edges of the central portion, a first lateral flange projecting outwardly from the first upturned region, and a second lateral flange projecting outwardly from the second upturned region.

[00211] The top plate and bottom plate central portions can be disposed beneath the pedestal roof of the side frame pedestal, and the first and second laterally projecting flanges of the top plate and the bottom plate can be disposed above the vertical shoulders of the roller bearing adapter and outside of the pedestal roof of the side frame pedestal and along the first and second outer sides of the side frame pedestal.

[00212] In another example, an adapter pad configured to be disposed between an adapter and a side frame pedestal roof of a railcar truck is disclosed. The adapter pad can include a top plate having inner and outer surfaces, a central portion, first and second upturned regions projecting upward from opposite edges of the central portion, a first lateral flange projecting outward from the first upturned region, and a second lateral flange projecting outward from the second upturned region; and a bottom plate having inner and outer surfaces, a central portion, first and second upturned regions projecting upward from opposite edges of the central portion, a first lateral flange projecting outward from the first upturned region, and a second lateral flange projecting outward from the second upturned region.

[00213] The outer surfaces of the first and second laterally projecting flanges of the bottom plate can be vertically higher than the outer surface of the central portion of the top plate.

[00214] In another example, a method for forming an adapter pad can include providing a top plate having a central portion, first and second upturned regions projecting upward from opposite edges of the central portion, a first lateral flange projecting outward from the first upturned lateral portion, and a second lateral flange projecting outward from the second upturned lateral portion; providing a bottom plate having a central portion, first and second upturned regions projecting upward from opposite edges of the central portion, a first lateral flange projecting outward from the first upturned lateral portion, and a second lateral flange projecting outward from the second upturned lateral portion; inserting a first outer elastomeric member between the first lateral flange of the top plate and the first lateral flange of the bottom plate; inserting a second outer elastomeric member between the second lateral flange of the top plate and the second lateral flange of the bottom plate; inserting a central elastomeric member between the central region of the top plate and the central region of the bottom plate; vulcanizing or curing the elastomeric members; inserting a first compression shim in the first lateral flange; and inserting a second compression shim in the second lateral flange. In some embodiments compression shims can be added after vulcanization or curing of the elastomer is complete.

[00215] In another example, a method for forming an adapter pad can include, providing a top plate having a central portion, first and second upturned regions projecting upward from opposite edges of the central portion, a first lateral flange projecting outward from the first upturned lateral portion, and a second lateral flange projecting outward from the second upturned lateral portion; providing a bottom plate having a central portion, first and second upturned regions projecting upward from opposite edges of the central portion, a first lateral flange projecting outward from the first upturned lateral portion, and a second lateral flange projecting outward from the second upturned lateral portion; inserting a first outer elastomeric member between the first lateral flange of the top plate and the first lateral flange of the bottom plate; and inserting a second outer elastomeric member between the second lateral flange of the top plate and the second lateral flange of the bottom plate; and inserting

a central elastomeric member between the central region of the top plate and the central region of the bottom plate; curing the elastomeric members; inserting a first compression shim in the first lateral flange; and inserting a second compression shim in the second lateral flange. The steps of inserting the first and second compression shims can be performed after curing the elastomeric members.

[00216] The compressing steps can compress the outer elastomeric member at least 0.02 inches of a static thickness of the outer elastomeric members. The compressing steps compress the outer elastomeric member greater than 7 percent of a static thickness of the outer elastomeric members.

[00217] In another example, an adapter pad system for use between a railcar side frame pedestal and a rail car axle roller bearing is disclosed. The side frame pedestal can define a first outer side, an opposite second outer side, and a pedestal roof located and extending between the first outer side and the second outer side. The adapter pad system can include a bearing adapter defining a bottom surface and a top surface, the bottom surface mounted to the railcar axle roller bearing. The adapter pad can be configured to interface with the bearing adapter and can further include a top plate having inner and outer surfaces, a central portion, and outer portions; a bottom plate having inner and outer surfaces, a central portion, and outer portions, and an elastomeric member having a central portion and outer portions disposed between the inner surfaces of the top and bottom plates.

[00218] The top plate and bottom plate central portions can be disposed beneath the pedestal roof of the side frame pedestal, and the outer portions of the top and bottom plate can be disposed outside of the pedestal roof of the side frame pedestal.

[00219] The adapter pad system can include a continuous top plate. The adapter pad system can include a continuous bottom plate.

[00220] The combined surface area of the outer portions of the elastomeric member at cross-sectional planes through the outer portions of the elastomeric members in planes centered between the inner surfaces of the top and bottom plates can be greater than 5 square inches.

[00221] The combined surface area of the outer portions of the elastomeric members at cross-sectional planes through the outer portions of the elastomeric

members in planes centered between the inner surfaces of the top and bottom plates can be at least 10 percent of the surface area of the central portion of the elastomeric member at a cross-sectional plane through the center of the central portion of the elastomeric member in a plane centered between the inner surfaces of the top and bottom plates.

[00222] The central portion of the elastomeric member can be in a different plane than the outer portions of the elastomeric member. The central portion of the elastomeric member can be in a parallel plane with the outer portions of the elastomeric member. The outer portions can be vertically spaced from the central portions.

[00223] The top plate can be engaged with the side frame, and the bottom plate can be engaged with the roller bearing adapter.

[00224] In another example, an adapter pad system for use between a railcar side frame pedestal and a rail car axle roller bearing is disclosed. The side frame pedestal can define a first outer side, an opposite second outer side, and a pedestal roof located and extending between the first outer side and the second outer side. The adapter pad system can include a bearing adapter defining a bottom surface and a top surface, the bottom surface mounted to the railcar axle roller bearing. The adapter pad system can include an adapter pad configured to interface with the bearing adapter that includes a top plate having inner and outer surfaces, a central portion, and outer portions; a bottom plate having inner and outer surfaces, a central portion, and outer portions, and an elastomeric member having a central portion and outer portions disposed between the inner surfaces of the top and bottom plates.

[00225] The top plate and bottom plate central portions can be disposed beneath the pedestal roof of the side frame pedestal, and the outer portions of the top and bottom plate can be disposed outside of the pedestal roof of the side frame pedestal.

[00226] The outer portions of the top and bottom plates can be configured to accept about 10 percent to 30 percent of vertical force applied to the central portions.

[00227] The outer portions of the adapter pad can be supported by vertical shoulders of the bearing adapter.

[00228] In another example, a roller bearing adapter configured to be disposed between a roller bearing and an adapter pad of a railcar truck is disclosed. The roller bearing adapter can have a bearing surface, an adapter crown surface, a longitudinal centerline, and first and second vertical shoulders that project upward from the pedestal crown surface of the adapter. The thickness of the center section of the roller bearing adapter can be less than 0.75 inches as measured at the longitudinal centerline from a bearing surface to a pedestal crown surface of the adapter.

[00229] The thickness of the roller bearing adapter can be between approximately 0.60 and 0.75 inches as measured at the longitudinal centerline from a bearing surface to a pedestal crown surface of the adapter. The width of the vertical shoulders can be at least 0.5 inches.

[00230] The roller bearing adapter can have a cross-sectional moment of inertia of a cross-section at the longitudinal centerline of the roller bearing adapter around a lateral axis about 5.2 inches above a center axis of an axle that is about 1.4 in^4 , or in the range of about 1.0 to about 2.0 in^4 . The lateral axis can be between about 5.0 inches and 5.5 inches from the center axis of the axle. The roller bearing adapter can have a cross-sectional moment of inertia of a cross-section at the longitudinal centerline of the roller bearing adapter around a vertical axis at the center of the adapter that can be about 86.8 in^4 , or in the range of about 50 to about 100 in^4 .

[00231] The present invention is disclosed above and in the accompanying drawings with reference to a variety of examples. The purpose served by the disclosure, however, is to provide examples of the various features and concepts related to the invention, not to limit the scope of the invention. The terms and descriptions used herein are set forth by way of illustration only and are not meant as limitations. One skilled in the relevant art will recognize that numerous variations and modifications may be made to the examples described above without departing from the scope of the present invention. For example, the steps of the methods need not be executed in a certain order, unless specified, although they may have been presented in that order in the disclosure.

CLAIMS

1. A railcar truck comprising:
 - a three-piece truck comprising:
 - a bolster;
 - a first side frame having a first pedestal of AAR standard geometry and a second pedestal of AAR standard geometry, and a second side frame having a third pedestal of AAR standard geometry and a fourth pedestal of AAR standard geometry, each side frame pedestal defining a first outer side and a second outer side and having a pedestal roof located and extending between the first outer side and the second outer side;
 - a first wheelset engaged with a first roller bearing and engaged with a second roller bearing;
 - a second wheelset engaged with a third roller bearing and engaged with a fourth roller bearing;
 - a first roller bearing adapter having AAR standard thrust lug clearances engaged with the first roller bearing, a second roller bearing adapter having AAR standard thrust lug clearances engaged with the second roller bearing, a third roller bearing adapter having AAR standard thrust lug clearances engaged with the third roller bearing, and a fourth roller bearing adapter having AAR standard thrust lug clearances engaged with the fourth roller bearing each roller bearing, each roller bearing adapter symmetrical about a lateral centerline and symmetrical about a longitudinal centerline, and defining a bottom surface and a crowned top surface, the top surface defining opposing first and second vertical shoulders that project upwardly from the top surface on either side of the side frame;
 - a first adapter pad engaged with the first pedestal roof and the first roller bearing adapter, a second adapter pad engaged with the second pedestal roof and the second roller bearing adapter, a third adapter pad engaged with the third pedestal roof and the third roller bearing adapter, a fourth adapter pad engaged with the fourth pedestal roof and the fourth roller bearing adapter, each adapter pad comprising:
 - a continuous top plate having a central portion, first and second upturned regions projecting upwardly from opposite edges of the central

portion, a first lateral flange projecting outwardly from the first upturned region, and a second lateral flange projecting outwardly from the second upturned region;

a continuous bottom plate having a central portion, first and second upturned regions projecting upwardly from opposite edges of the central portion, a first lateral flange projecting outwardly from the first upturned region, and a second lateral flange projecting outwardly from the second upturned region;

a first outer elastomeric member disposed between the first lateral flanges of the top and bottom plates, defining a first outer edge, and having a static thickness within the range of 0.15 inches to 0.30 inches;

a second outer elastomeric member disposed between the second lateral flanges of the top and bottom plates, defining a second outer edge, and having a static thickness within the range of 0.15 inches to 0.30 inches;

a central elastomeric member disposed between the central portion of the top and bottom plates, defining a third outer edge, having a substantially uniform thickness, and having a static thickness within the range of 0.15 inches to 0.25 inches;

a first substantially hollow portion disposed between the top plate and the bottom plate and between the central elastomeric member and the first outer elastomeric member;

a second substantially hollow portion disposed between the top plate and the bottom plate and between the central elastomeric member and the second outer elastomeric member;

a first lateral adapter grip disposed between an inside surface of the first vertical shoulder of the engaged roller bearing adapter and the first upturned region of the bottom plate;

a second lateral adapter grip disposed between an inside surface of the second vertical shoulder of the engaged roller bearing adapter and the second upturned region of the bottom plate;

a first lateral side frame grip disposed between an outer surface of the first upturned region of the top plate and the first outer side of the engaged side frame pedestal;

a second lateral side frame grip disposed between an outer surface of the second upturned region of the top plate and the second outer side of the engaged side frame pedestal;

wherein the top plate and bottom plate central portions and the central elastomeric member of each adapter pad are disposed at least in part beneath the engaged pedestal roof, and the first and second laterally projecting flanges of the top plate and the bottom plate and the first and second outer elastomeric members of each adapter pad are entirely disposed above the vertical shoulders of the engaged roller bearing adapter and outside of the engaged pedestal roof;

wherein the combined top plate, bottom plate, and elastomeric members of each of the adapter pads provide a longitudinal stiffness of at least 45,000 pounds per inch through a longitudinal displacement of the top plate relative to the bottom plate of up to 0.139 inches from a central position, a lateral stiffness of at least 45,000 pounds per inch through a lateral displacement of the top plate relative to the bottom plate of up to 0.234 inches from the central position, and a rotational stiffness of at least 250,000 pound *inches per radian of rotation through a rotational displacement of the top plate relative to the bottom plate of up to 41 milliradians from the central position when a vertical load of 35,000 pounds is applied to the central portions of the adapter pad.

2. The railcar truck of claim 1, wherein the top plate, bottom plate, and elastomeric member of the adapter pad provide a vertical stiffness of at least 5,000,000 pounds per inch through a vertical displacement of the top plate relative to the bottom plate up to 0.05 inches.

3. The railcar truck of claim 1, wherein a first outer elastomeric member, the second outer elastomeric member, and the central elastomeric member are comprised of natural rubber.

4. The railcar truck of claim 1, wherein a first outer elastomeric member, the second outer elastomeric member, and the central elastomeric member have a durometer between 65-80 Shore A.
5. The railcar truck of claim 1, wherein the first outer elastomeric member and the second outer elastomeric member of each of the adapter pads are precompressed between the respective first lateral flanges of the top and bottom plates and the second lateral flanges of the top and bottom plates.
6. The railcar truck of claim 1, wherein the top plate of each adapter pad is fixedly engaged with the side frame such that movement between the top plate and the side frame is restricted.
7. The railcar truck of claim 1, wherein the bottom plate of each adapter pad is fixedly engaged with the roller bearing adapter such that movement between the bottom plate and each roller bearing adapter is restricted.
8. The railcar truck of claim 1, further comprising longitudinal stops on each roller bearing adapter configured to restrict longitudinal movement of the bottom plate of each adapter pad with respect to the engaged roller bearing adapter.
9. The railcar truck of claim 1, wherein the vertical shoulders of each roller bearing adapter are configured to restrict lateral movement of the bottom plate of each adapter pad with respect to the engaged roller bearing adapter.
10. The railcar truck of claim 1, wherein the thickness of the outer elastomeric members is precompressed at least 0.020 inches from a static state.
11. The railcar truck of claim 1, wherein the thickness of the outer elastomeric members is precompressed at least 7% from a static state.

12. The railcar truck of claim 1, wherein the shear stiffness of adapter pad is configured to allow the roller bearing adapter to return to a central position within the side frame pedestal opening.

13. The railcar truck of claim 1, the surface area of the first outer elastomeric member at a cross-sectional plane through the first outer elastomeric member centered between the inner surfaces the top and bottom plates is greater than 2.5 square inches; and the surface area of the second outer elastomeric member at a cross-sectional plane through second outer elastomeric member in a plane centered between the inner surfaces of the top and bottom plates is greater than 2.5 square inches.

14. The railcar truck of claim 1, wherein the combined surface area of the first and second outer elastomeric members at cross-sectional planes through the first and second outer elastomeric members in planes centered between the inner surfaces of the top and bottom plates is greater than 5 square inches.

15. The railcar truck of claim 1, wherein the combined surface area of the first and second outer elastomeric members at cross-sectional planes through the first and second outer elastomeric members in planes centered between the inner surfaces of the top and bottom plates is at least 10 percent of the surface area of the central elastomeric member at a cross-section plane through the center of the central elastomeric member in a centered between the inner surfaces of the top and bottom plates.

16. The railcar truck of claim 1, wherein at least a portion of one of the first, second, and third outer edges is curved from a top view.

17. A railcar truck comprising:
a three-piece truck comprising:
a bolster;

at least one side frame having at least one side frame pedestal defining a first outer side and a second outer side, and a pedestal roof located and extending between the first outer side and the second outer side;

at least one wheelset positioned transversely with the at least one side frame;

at least one roller bearing engaged with the at least one wheelset;

at least one roller bearing adapter, defining a bottom surface and a top surface, the bottom surface engaged with the roller bearing, the top surface defining opposing first and second vertical shoulders that project upwardly from the top surface, on either side of the at least one side frame;

at least one adapter pad configured to engage with the at least one roller bearing adapter and the pedestal roof, the at least one adapter pad comprising:

- a top plate having a central portion, first and second upturned regions projecting upwardly from opposite edges of the central portion, a first lateral flange projecting outwardly from the first upturned region, and a second lateral flange projecting outwardly from the second upturned region;
- a bottom plate having a central portion, first and second upturned regions projecting upwardly from opposite edges of the central portion, a first lateral flange projecting outwardly from the first upturned region, and a second lateral flange projecting outwardly from the second upturned region;
- a first outer elastomeric member disposed between the first lateral flanges of the top and bottom plates;
- a second outer elastomeric member disposed between the second lateral flanges of the top and bottom plates;
- a central elastomeric member disposed between the central portion of the top and bottom plates;
- a first substantially hollow portion disposed between the top plate and the bottom plate and between the central elastomeric member and the first outer elastomeric member;
- a second substantially hollow portion disposed between the top plate and the bottom plate and between the central elastomeric member and the second outer elastomeric member;

wherein the top plate and bottom plate central portions and the central elastomeric member are disposed at least in part beneath the pedestal roof, and the first and second laterally projecting flanges of the top plate and the bottom plate and the first and second outer elastomeric members are disposed above the vertical shoulders of the roller bearing adapter and entirely outside of the pedestal roof;

wherein the top plate of the at least one adapter pad is engaged with the at least one side frame such that movement between the top plate and the at least one side frame is restricted, and wherein the bottom plate of the adapter pad is engaged with the roller bearing adapter such that movement between the bottom plate and the roller bearing adapter is restricted.

18. The railcar truck of claim 17, wherein the combined top plate, bottom plate, and elastomeric member of the adapter pad provide a longitudinal stiffness of at least 45,000 pounds per inch through a longitudinal displacement of the top plate relative to the bottom plate of up to 0.139 inches from a central position, when a vertical load of 35,000 pounds is applied to the central portions of the adapter pad.

19. The railcar truck of claim 18, wherein the longitudinal hysteresis is less than about 1500 lbs.

20. The railcar truck of claim 17, wherein the combined top plate, bottom plate, and elastomeric member of the adapter pad provides a lateral stiffness of at least 45,000 pounds per inch through a lateral displacement of the top plate relative to the bottom plate of up to 0.234 inches from a central position, when a vertical load of 35,000 pounds is applied to the central portions of the adapter pad.

21. The railcar truck of claim 20, wherein the lateral displacement hysteresis is less than about 6,000 lbs.

22. The railcar truck of claim 17, wherein the top plate, bottom plate, and elastomeric member of the adapter pad provide a rotational stiffness of at least 250,000 pound *inches per radian of rotation through a rotational displacement of the

top plate relative to the bottom plate of up to 41 milliradians from a central position when a vertical load of 35,000 pounds is applied to the central portions of the adapter pad.

23. The railcar truck of claim 22, wherein the twist hysteresis is less than about 16,000 lbs*in.

24. A railcar truck comprising:

a three-piece truck comprising:

a bolster;

a side frame having a side frame pedestal defining a first outer side and a second outer side, and a pedestal roof located and extending between the first outer side and the second outer side;

a wheelset;

a roller bearing engaged with the wheelset;

a roller bearing adapter, defining a bottom surface and a top surface, the bottom surface engaged with the roller bearing, the top surface defining opposing first and second vertical shoulders that project upwardly from the top surface on either side of the side frame;

an adapter pad configured to engage with the roller bearing adapter and the pedestal roof, the adapter pad comprising:

a top plate having a central portion, first and second upturned regions projecting upwardly from opposite edges of the central portion, a first lateral flange projecting outwardly from the first upturned region, and a second lateral flange projecting outwardly from the second upturned region;

a bottom plate having a central portion, first and second upturned regions projecting upwardly from opposite edges of the central portion, a first lateral flange projecting outwardly from the first upturned region, and a second lateral flange projecting outwardly from the second upturned region;

a first outer elastomeric member disposed between the first lateral flanges of the top and bottom plates;

a second outer elastomeric member disposed between the second lateral flanges of the top and bottom plates;

a central elastomeric member disposed between the central portion of the top and bottom plates;

wherein the top plate and bottom plate central portions and the central elastomeric member are disposed at least in part beneath the pedestal roof, and the first and second laterally projecting flanges of the top plate and the bottom plate and the first and second outer elastomeric members are disposed above the vertical shoulders of the roller bearing adapter and entirely outside of the pedestal roof;

wherein the top plate of the adapter pad is fixedly engaged with the side frame such that movement between the top plate and the side frame is restricted, and wherein the bottom plate of the adapter pad is fixedly engaged with the roller bearing such that movement between the bottom plate and the roller bearing is restricted; and

wherein the combined surface area of the first and second outer elastomeric members at cross-sectional planes through the first and second outer elastomeric members in planes centered between the inner surfaces of the top and bottom plates is at least 10 percent of the surface area of the central elastomeric member at a cross-section plane through the center of the central elastomeric member in a centered between the inner surfaces of the top and bottom plates.

25. A roller bearing adapter pad system configured for use with a three-piece truck having AAR standard geometry comprising:

a roller bearing adapter configured to engage a roller bearing, the roller bearing adapter comprising:

a crowned top surface;

a bottom surface configured to engage a roller bearing;

first and second vertical shoulders that project upwardly from opposite lateral edges of the top surface, each vertical shoulder having a width of at least 0.5 inches;

first and second longitudinal stops that project upwardly from opposite longitudinal edges of the top surface;

wherein the roller bearing adapter is symmetrical about a lateral centerline and symmetrical about a longitudinal centerline

wherein the thickness of the roller bearing adapter measured between the crowned top surface and the bottom surface is less than 0.75 inches as measured at the longitudinal centerline;

wherein the roller bearing adapter has cross-sectional moment of inertia of a cross-section at the longitudinal centerline of the roller bearing adapter around a lateral axis about 5.2 inches above a center axis of an axle that is in the range of about 1.0 in^4 to about 2.0 in^4 ;

wherein the roller bearing adapter has a cross-sectional moment of inertia of a cross-section at the longitudinal centerline of the roller bearing adapter around a vertical axis at the center of the adapter that is in the range of about 50 in^4 to about 100 in^4 ;

an adapter pad engaged with the roller bearing adapter and configured to engage a side frame pedestal roof, the adapter pad comprising:

a continuous top plate having a central portion, first and second upturned regions projecting upwardly from opposite edges of the central portion, a first lateral flange projecting outwardly from the first upturned region, and a second lateral flange projecting outwardly from the second upturned region;

a continuous bottom plate having a central portion, first and second upturned regions projecting upwardly from opposite edges of the central portion, a first lateral flange projecting outwardly from the first upturned region, and a second lateral flange projecting outwardly from the second upturned region;

a first outer elastomeric member disposed between the first lateral flanges of the top and bottom plates, having a static thickness within the range of 0.15 inches to 0.30 inches;

a second outer elastomeric member disposed between the second lateral flanges of the top and bottom plates, having a static thickness within the range of 0.15 inches to 0.30 inches;

a central elastomeric member disposed between the central portion of the top and bottom plates, having uniform thickness, having a substantially uniform static thickness within the range of 0.15 inches to 0.25 inches;

a first substantially hollow portion disposed between the top plate and the bottom plate and between the central elastomeric member and the first outer elastomeric member;

a second substantially hollow portion disposed between the top plate and the bottom plate and between the central elastomeric member and the second outer elastomeric member;

a first lateral adapter grip disposed between an inside surface of the first vertical shoulder of the engaged roller bearing adapter and the first upturned region of the bottom plate;

a second lateral adapter grip disposed between an inside surface of the second vertical shoulder of the engaged roller bearing adapter and the second upturned region of the bottom plate;

a first lateral side frame grip disposed on an outer surface of the first upturned region of the top plate;

a second lateral side frame grip disposed between an outer surface of the second upturned region of the top plate;

wherein the first and second laterally projecting flanges of the top plate and the bottom plate and the first and second outer elastomeric members of each adapter pad are entirely disposed above the vertical shoulders of the roller bearing adapter.

26. The roller bearing adapter pad system of claim 25, wherein the thickness of the adapter is between 0.60 and 0.75 inches as measured at the longitudinal centerline from bottom surface to the crowned top surface of the roller bearing adapter.

27. The roller bearing adapter pad system of claim 25, wherein the first outer elastomeric member and the second outer elastomeric member of each of the

adapter pads are precompressed between the respective first lateral flanges of the top and bottom plates and the second lateral flanges of the top and bottom plates.

28. The roller bearing adapter pad system of claim 25, wherein the bottom plate of each adapter pad is fixedly engaged with the roller bearing adapter such that movement between the bottom plate and each roller bearing adapter is restricted.

29. A roller bearing adapter pad system configured for use with a three-piece truck having AAR standard geometry comprising:

a roller bearing adapter configured to engage a roller bearing, the roller bearing adapter comprising:

a top surface;

a bottom surface configured to engage a roller bearing;

first and second vertical shoulders that project upwardly from opposite lateral edges of the top surface, each vertical shoulder having a width of at least 0.5 inches and a height in the range of 0.75 inches to 1.5 inches;

an adapter pad engaged with the roller bearing adapter and configured to engage a side frame pedestal roof, the adapter pad comprising:

a continuous top plate having a central portion, first and second upturned regions projecting upwardly from opposite edges of the central portion, a first lateral flange projecting outwardly from the first upturned region, and a second lateral flange projecting outwardly from the second upturned region;

a continuous bottom plate having a central portion, first and second upturned regions projecting upwardly from opposite edges of the central portion, a first lateral flange projecting outwardly from the first upturned region, and a second lateral flange projecting outwardly from the second upturned region;

a first outer elastomeric member disposed between the first lateral flanges of the top and bottom plates, defining a first outer edge;

a second outer elastomeric member disposed between the second lateral flanges of the top and bottom plates, defining a second outer edge;

a central elastomeric member disposed between the central portion of the top and bottom plates, defining a third outer edge;

a first substantially hollow portion disposed between the top plate and the bottom plate and between the central elastomeric member and the first outer elastomeric member;

a second substantially hollow portion disposed between the top plate and the bottom plate and between the central elastomeric member and the second outer elastomeric member;

wherein the first and second laterally projecting flanges of the top plate and the bottom plate and the first and second outer elastomeric members of each adapter pad are entirely disposed above the vertical shoulders of the roller bearing adapter;

wherein the combined surface area of the first and second outer elastomeric members at cross-sectional planes through the first and second outer elastomeric members in planes centered between the inner surfaces of the top and bottom plates is at least 10 percent of the surface area of the central elastomeric member at a cross-section plane through the center of the central elastomeric member in a centered between the inner surfaces of the top and bottom plates; and

wherein the combined top plate, bottom plate, and elastomeric members provide a longitudinal stiffness of at least 45,000 pounds per inch through a longitudinal displacement of the top plate relative to the bottom plate of up to 0.139 inches from a central position, a lateral stiffness of at least 45,000 pounds per inch through a lateral displacement of the top plate relative to the bottom plate of up to 0.234 inches from the central position, and a rotational stiffness of at least 250,000 pound *inches per radian of rotation through a rotational displacement of the top plate relative to the bottom plate of up to 41 milliradians from the central position when a vertical load of 35,000 pounds is applied to the central portions of the adapter pad.

30. The roller bearing adapter pad system of claim 29, wherein a first outer elastomeric member, the second outer elastomeric member, and the central elastomeric member are comprised of natural rubber.

31. The roller bearing adapter pad system of claim 29, wherein a first outer elastomeric member, the second outer elastomeric member, and the central elastomeric member have a hardness between 65-80 Shore A durometer.
32. The roller bearing adapter pad system of claim 29, wherein the first and second outer elastomeric members have a static thickness that is greater than a static thickness of the central elastomeric member.
33. The roller bearing adapter pad system of claim 29, the surface area of the first outer elastomeric member at a cross-sectional plane through the first outer elastomeric member centered between the inner surfaces the top and bottom plates is greater than 2.5 square inches; and the surface area of the second outer elastomeric member at a cross-sectional plane through second outer elastomeric member in a plane centered between the inner surfaces of the top and bottom plates is greater than 2.5 square inches.
34. The roller bearing adapter pad system of claim 29, wherein the combined surface area of the first and second outer elastomeric members at cross-sectional planes through the first and second outer elastomeric members in planes centered between the inner surfaces of the top and bottom plates is greater than 5 square inches.
35. The roller bearing adapter pad system of claim 29, wherein the first and second outer edges include a continuous radius measured from a center point of the central portion of the top plate.
36. A roller bearing adapter pad configured for use with a three-piece truck comprising:
a continuous top plate having a central portion, first and second upturned regions projecting upwardly from opposite edges of the central portion, a first lateral

flange projecting outwardly from the first upturned region, and a second lateral flange projecting outwardly from the second upturned region;

a continuous bottom plate having a central portion, first and second upturned regions projecting upwardly from opposite edges of the central portion, a first lateral flange projecting outwardly from the first upturned region, and a second lateral flange projecting outwardly from the second upturned region;

a first outer elastomeric member disposed between the first lateral flanges of the top and bottom plates;

a second outer elastomeric member disposed between the second lateral flanges of the top and bottom plates;

a central elastomeric member disposed between the central portion of the top and bottom plates;

a first substantially hollow portion disposed between the top plate and the bottom plate and between the central elastomeric member and the first outer elastomeric member;

a second substantially hollow portion disposed between the top plate and the bottom plate and between the central elastomeric member and the second outer elastomeric member;

wherein the combined top plate, bottom plate, and elastomeric members provide a longitudinal stiffness of at least 45,000 pounds per inch through a longitudinal displacement of the top plate relative to the bottom plate of up to 0.139 inches from a central position, a lateral stiffness of at least 45,000 pounds per inch through a lateral displacement of the top plate relative to the bottom plate of up to 0.234 inches from the central position, and a rotational stiffness of at least 250,000 pound *inches per radian of rotation through a rotational displacement of the top plate relative to the bottom plate of up to 41 milliradians from the central position when a vertical load of 35,000 pounds is applied to the central portions of the adapter pad.

37. The roller bearing adapter pad of claim 36, wherein the top plate, bottom plate, and elastomeric member of the adapter pad provide a vertical stiffness of at

least 5,000,000 pounds per inch through a vertical displacement of the top plate relative to the bottom plate up to 0.05 inches.

38. The roller bearing adapter pad of claim 36, wherein the top plate has a uniform thickness, and the bottom plate has a non-uniform thickness.
39. The roller bearing adapter pad of claim 36, wherein the combined top plate, bottom plate, and elastomeric members of the adapter pad provide a shear strain that does not exceed 120% under maximum displacement.
40. The roller bearing adapter pad of claim 36, wherein the longitudinal hysteresis is less than about 1500 lbs.
41. The roller bearing adapter pad of claim 36, wherein the lateral displacement hysteresis is less than about 6,000 lbs.
42. The roller bearing adapter pad of claim 36, wherein the twist hysteresis is less than about 16,000 lbs*in.
43. A roller bearing adapter pad system configured for use with a three-piece truck having AAR standard geometry comprising:
a roller bearing adapter configured to engage a roller bearing, the roller bearing adapter comprising:
a crowned top surface;
a bottom surface configured to engage a roller bearing;
wherein the roller bearing adapter has cross-sectional moment of inertia of a cross-section at the longitudinal centerline of the roller bearing adapter around a lateral axis about 5.2 inches above a center axis of an axle that is in the range of about 1.0 in⁴ to about 2.0 in⁴; and
wherein the roller bearing adapter has a cross-sectional moment of inertia of a cross-section at the longitudinal centerline of the roller bearing

adapter around a vertical axis at the center of the adapter that is in the range of about 50 in⁴ to about 100 in⁴; and

an adapter pad engaged with the roller bearing adapter and configured to engage a side frame pedestal roof, the adapter pad comprising:

- a continuous top plate;
- a continuous bottom plate;
- an elastomeric member disposed between the top and bottom plates, having a static thickness within the range of 0.15 inches to 0.30 inches;
- wherein the surface area of the elastomeric member at a cross-sectional plane centered between the inner surfaces of the top and bottom plates is greater than about 50 square inches;
- wherein the combined top plate, bottom plate, and elastomeric members provide a longitudinal stiffness of at least 45,000 pounds per inch through a longitudinal displacement of the top plate relative to the bottom plate of up to 0.139 inches from a central position, a lateral stiffness of at least 45,000 pounds per inch through a lateral displacement of the top plate relative to the bottom plate of up to 0.234 inches from the central position, and a rotational stiffness of at least 250,000 pound *inches per radian of rotation through a rotational displacement of the top plate relative to the bottom plate of up to 41 milliradians from the central position when a vertical load of 35,000 pounds is applied to the central portion of the adapter pad.

44. A method for forming a railcar truck comprising:
- providing a three-piece truck comprising:
 - a bolster;
 - a first side frame having a first pedestal of AAR standard geometry and a second pedestal of AAR standard geometry, and a second side frame having a third pedestal of AAR standard geometry and a fourth pedestal of AAR standard geometry, each side frame pedestal defining a first outer side and a second outer side and having a pedestal roof located and extending between the first outer side and the second outer side;

providing a first wheelset engaged with a first roller bearing and engaged with a second roller bearing;

providing a second wheelset engaged with a third roller bearing and engaged with a fourth roller bearing;

providing a first roller bearing adapter having AAR standard thrust lug clearances engaged with the first roller bearing, a second roller bearing adapter having AAR standard thrust lug clearances engaged with the second roller bearing, a third roller bearing adapter having AAR standard thrust lug clearances engaged with the third roller bearing, and a fourth roller bearing adapter having AAR standard thrust lug clearances engaged with the fourth roller bearing each roller bearing, each roller bearing adapter symmetrical about a lateral centerline and symmetrical about a longitudinal centerline, and defining a bottom surface and a crowned top surface, the top surface defining opposing first and second vertical shoulders that project upwardly from the top surface on either side of the side frame;

providing a first adapter pad, a second adapter pad, a third adapter pad, a fourth adapter pad, each adapter pad comprising:

a continuous top plate having a central portion, first and second upturned regions projecting upwardly from opposite edges of the central portion, a first lateral flange projecting outwardly from the first upturned region, and a second lateral flange projecting outwardly from the second upturned region;

a continuous bottom plate having a central portion, first and second upturned regions projecting upwardly from opposite edges of the central portion, a first lateral flange projecting outwardly from the first upturned region, and a second lateral flange projecting outwardly from the second upturned region;

a first outer elastomeric member disposed between the first lateral flanges of the top and bottom plates, defining a first outer edge, and having a static thickness within the range of 0.15 inches to 0.30 inches;

a second outer elastomeric member disposed between the second lateral flanges of the top and bottom plates, defining a second outer edge, and having a static thickness within the range of 0.15 inches to 0.30 inches;

a central elastomeric member disposed between the central portion of the top and bottom plates, defining a third outer edge, and having a static thickness within the range of 0.15 inches to 0.25 inches;

a first substantially hollow portion disposed between the top plate and the bottom plate and between the central elastomeric member and the first outer elastomeric member;

a second substantially hollow portion disposed between the top plate and the bottom plate and between the central elastomeric member and the second outer elastomeric member;

a first elastomeric lateral adapter grip disposed between an inside surface of the first vertical shoulder of the engaged roller bearing adapter and the first upturned region of the bottom plate;

a second elastomeric lateral adapter grip disposed between an inside surface of the second vertical shoulder of the engaged roller bearing adapter and the second upturned region of the bottom plate;

a first elastomeric lateral side frame grip disposed between an outer surface of the first upturned region of the top plate and the first outer side of the engaged side frame pedestal;

a second elastomeric lateral side frame grip disposed between an outer surface of the second upturned region of the top plate and the second outer side of the engaged side frame pedestal;

engaging the first adapter pad with the first pedestal roof and the first roller bearing adapter such that movement of the top plate of the first adapter pad relative to the pedestal roof is restricted and that movement between the bottom plate of the first adapter pad relative to the first roller bearing adapter is restricted;

engaging the second adapter pad with the second pedestal roof and the second roller bearing adapter such that movement of the top plate of the second adapter pad relative to the pedestal roof is restricted and that movement between the bottom plate of the second adapter pad relative to the second roller bearing adapter is restricted;

engaging the third adapter pad with the third pedestal roof and the third roller bearing adapter such that movement of the top plate of the third adapter pad relative

to the pedestal roof is restricted and that movement between the bottom plate of the third adapter pad relative to the third roller bearing adapter is restricted;

engaging the fourth adapter pad with the fourth pedestal roof and the fourth roller bearing adapter such that movement of the top plate of the fourth adapter pad relative to the pedestal roof is restricted and that movement between the bottom plate of the fourth adapter pad relative to the fourth roller bearing adapter is restricted;

wherein the top plate and bottom plate central portions and the central elastomeric member of each adapter pad are disposed at least in part beneath the engaged pedestal roof, and the first and second laterally projecting flanges of the top plate and the bottom plate and the first and second outer elastomeric members of each adapter pad are entirely disposed above the vertical shoulders of the engaged roller bearing adapter and outside of the engaged pedestal roof.

45. The method of claim 44, further comprising:

producing plastic deformation of the first lateral flange of the top plate of each of the adapter pads and the first lateral flange of the bottom plate of each of the adapter pads in a direction towards each other to compress the first outer elastomeric member; and

producing plastic deformation of the second lateral flange of the top plate of each of the adapter pads and the second lateral flange of the bottom plate of each of the adapter pads in a direction towards each other to compress the second outer elastomeric member.

46. The method of claim 45, wherein the steps of producing deformation of the first and second lateral flange of each of the adapter pads occurs during molding of the adapter pad.

47. The method of claim 45, wherein the compressing steps apply at least 3,000 pounds of compression.

48. The method of claim 45, wherein the compressing steps compress the outer elastomeric members of each of the adapter pads at least 0.02 inches of a static thickness of the outer elastomeric members.

49. The method of claim 45, wherein the compressing steps compress the outer elastomeric members of each of the adapter pads at least 7 percent of a static thickness of the outer elastomeric members.

50. A method of forming an adapter pad system configured for use with three-piece truck having AAR standard geometry comprising:

providing a roller bearing adapter with AAR standard thrust lug clearances engaged with the first roller bearing, the roller bearing adapter symmetrical about a lateral centerline and symmetrical about a longitudinal centerline, and defining a bottom surface and a crowned top surface, the top surface defining opposing first and second vertical shoulders that project upwardly from the top surface,

providing an adapter pad configured to engage a pedestal roof and the roller bearing adapter the adapter pad comprising:

providing a continuous top plate having a central portion, first and second upturned regions projecting upwardly from opposite edges of the central portion, a first lateral flange projecting outwardly from the first upturned region, and a second lateral flange projecting outwardly from the second upturned region;

providing a continuous bottom plate having a central portion, first and second upturned regions projecting upwardly from opposite edges of the central portion, a first lateral flange projecting outwardly from the first upturned region, and a second lateral flange projecting outwardly from the second upturned region;

providing a first outer elastomeric member disposed between the first lateral flanges of the top and bottom plates;

providing a second outer elastomeric member disposed between the second lateral flanges of the top and bottom plates;

providing a central elastomeric member disposed between the central portion of the top and bottom plates;

providing a first substantially hollow portion disposed between the top plate and the bottom plate and between the central elastomeric member and the first outer elastomeric member;

providing a second substantially hollow portion disposed between the top plate and the bottom plate and between the central elastomeric member and the second outer elastomeric member;

compressing the first and second outer elastomeric members;

engaging the adapter pad with the first roller bearing adapter such that movement of the bottom plate of the first adapter pad with respect to the roller bearing adapter is restricted;

wherein the first and second laterally projecting flanges of the top plate and the bottom plate and the first and second outer elastomeric members of each adapter pad are entirely disposed above the vertical shoulders of the roller bearing adapter.

51. The method of claim 50, wherein the step of compressing the first and second outer elastomeric members further comprise inserting a first compression shim between the first lateral flanges of the top and bottom plates and inserting a second compression shim between the second lateral flanges of the top and bottom plates after molding the adapter pad.

52. The method of claim 50, wherein the step of compressing the first and second outer elastomeric members further comprise inserting a first compression shim between the first lateral flange of the bottom plate and the first vertical shoulder and inserting a second compression shim between the second lateral flange of the bottom plate and the second vertical shoulder.

53. The method of claim 52, wherein the first and second compression shims are formed during the process of molding the adapter pad.

54. The method of claim 50, wherein the compressing step applies at least 3,000 pounds of compression.

55. The method of claim 50, wherein the compressing step compresses the outer elastomeric members greater than 7 percent of a static thickness of the outer elastomeric members.

56. The method of claim 50, wherein the thickness of the central elastomeric member is less than or equal to the thickness of the first and second outer elastomeric members.

57. A method for forming an adapter pad comprising:

providing a continuous top plate having a central portion, first and second upturned regions projecting upward from opposite edges of the central portion, a first lateral flange projecting outward from the first upturned region, and a second lateral flange projecting outward from the second upturned region;

providing a continuous bottom plate having a central portion, first and second upturned regions projecting upward from opposite edges of the central portion, a first lateral flange projecting outward from the first upturned region, and a second lateral flange projecting outward from the second upturned region;

inserting a first outer elastomeric member between the first lateral flanges of the top and bottom plates;

inserting a second outer elastomeric member between the second lateral flanges of the top and bottom plates;

inserting a central elastomeric member between the central portion of the top and bottom plates; and

forming a first substantially hollow portion disposed between the top plate and the bottom plate and between the central elastomeric member and the first outer elastomeric member;

forming a second substantially hollow portion disposed between the top plate and the bottom plate and between the central elastomeric member and the second outer elastomeric member;

compressing the first outer elastomeric members; and
compressing the second outer elastomeric members.

58. The method of claim 57, wherein before the compressing steps, the first lateral flange of the top plate projects outward and downward from the first upturned lateral portion, the second lateral flange of the top plate projects outward and downward from the second upturned lateral portion, the first lateral flange of the bottom plate projects outward and upward from the first upturned lateral portion, and a second lateral flange projects outward and upward from the second upturned lateral portion.

59. The method of claim 57, further comprising adhering the elastomeric members to the top and bottom plates during a molding process.

60. The method of claim 57, wherein the step of compressing the first and second outer elastomeric members further comprise inserting a first compression shim between the first lateral flanges of the top and bottom plates and inserting a second compression shim between the second lateral flanges of the top and bottom plates after a molding process.

61. The method of claim 60, wherein the step of compressing the first and second outer elastomeric members further comprise inserting a first compression shim between the first lateral flanges of the top and bottom plates and inserting a second compression shim between the second lateral flanges of the top and bottom plates.

62. The method of claim 57, wherein the compressing is accomplished by creating plastic deformation of the first and second lateral flange.

63. The method of claim 57, wherein the compressing steps compress the outer elastomeric member greater than 7 percent of a static thickness of the outer elastomeric members.

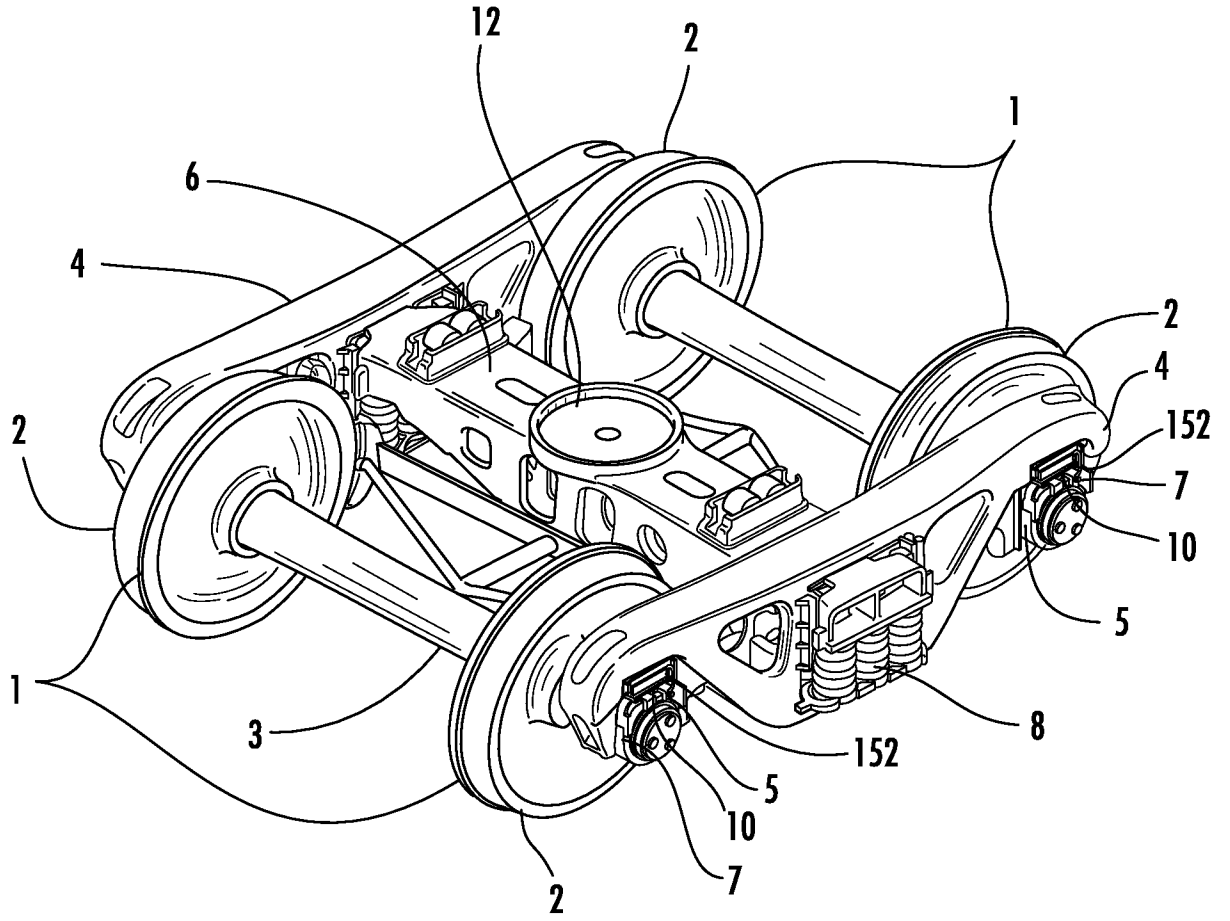

FIG. 1A

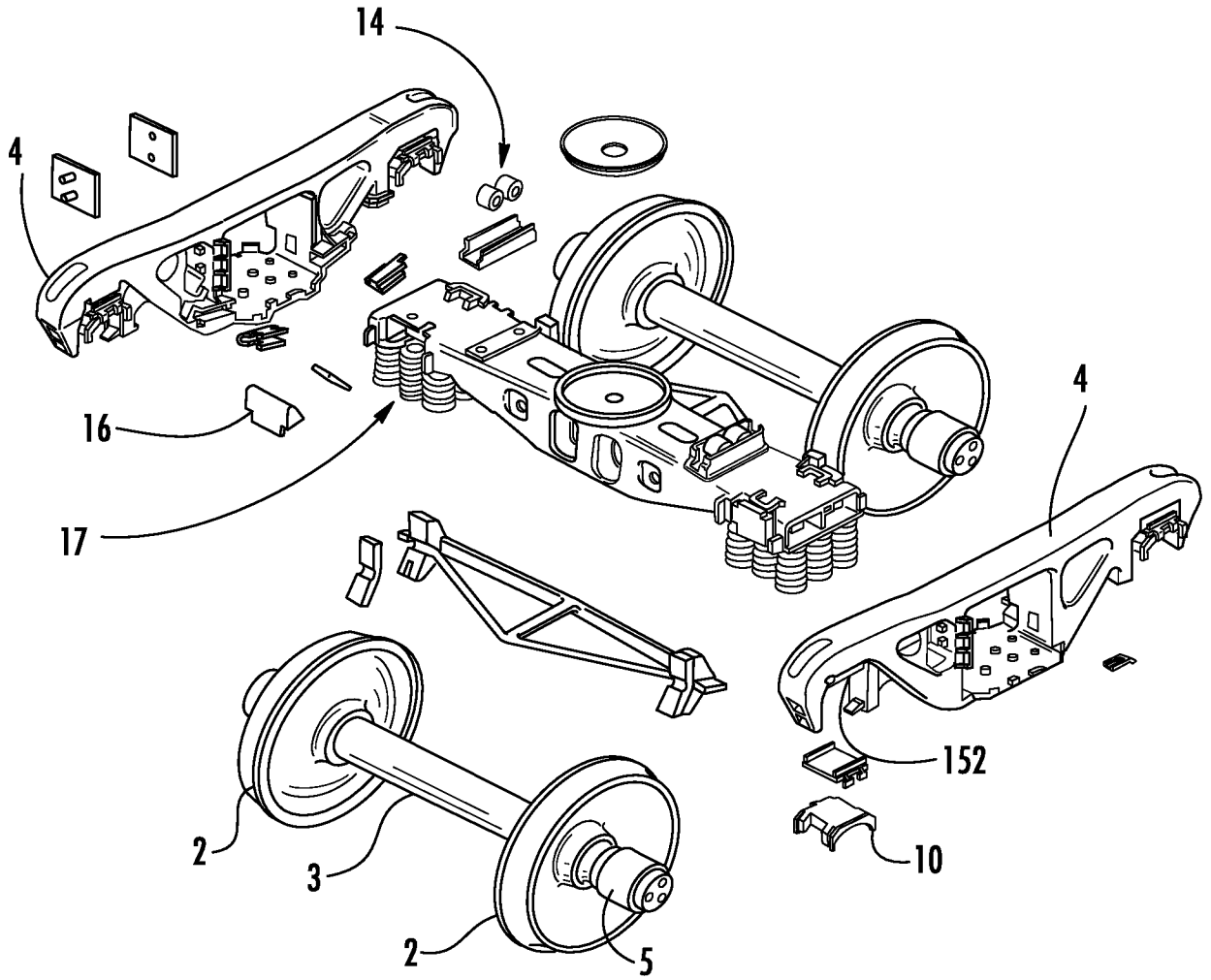

FIG. 1B

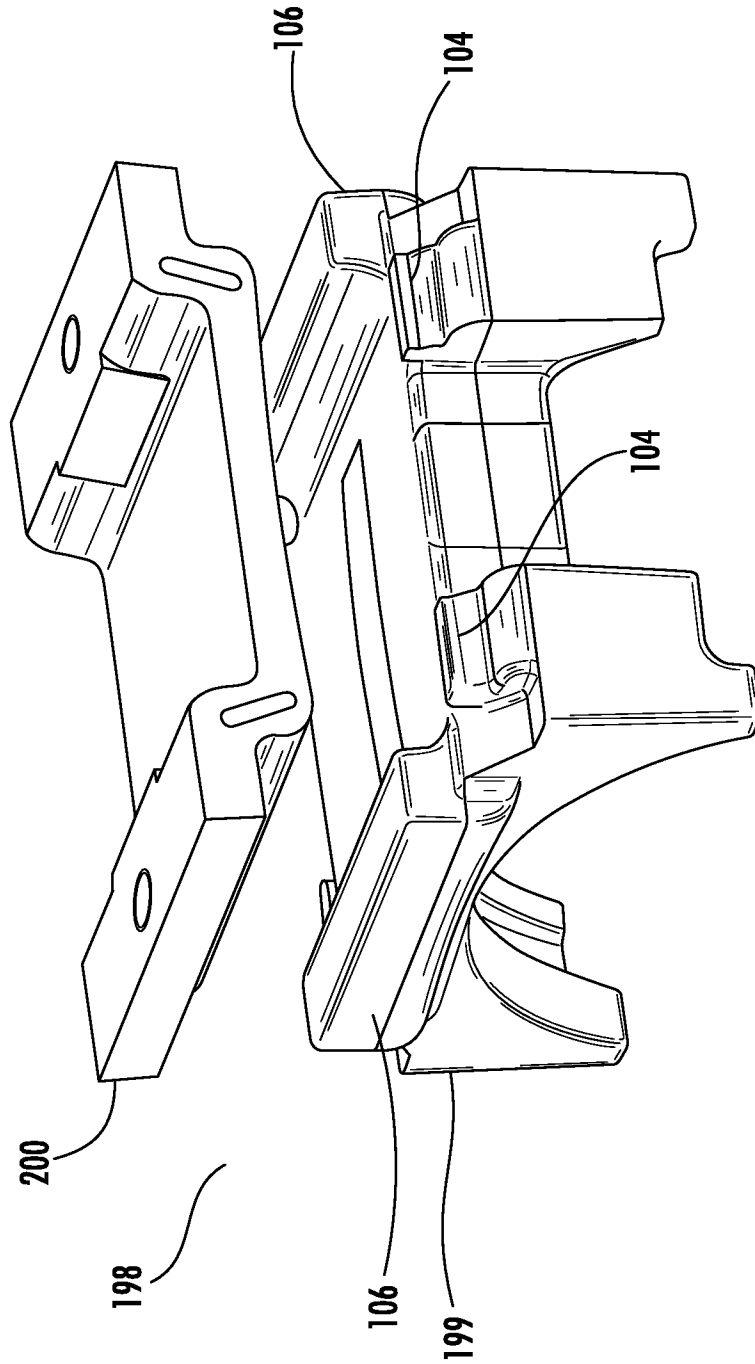

FIG. 2

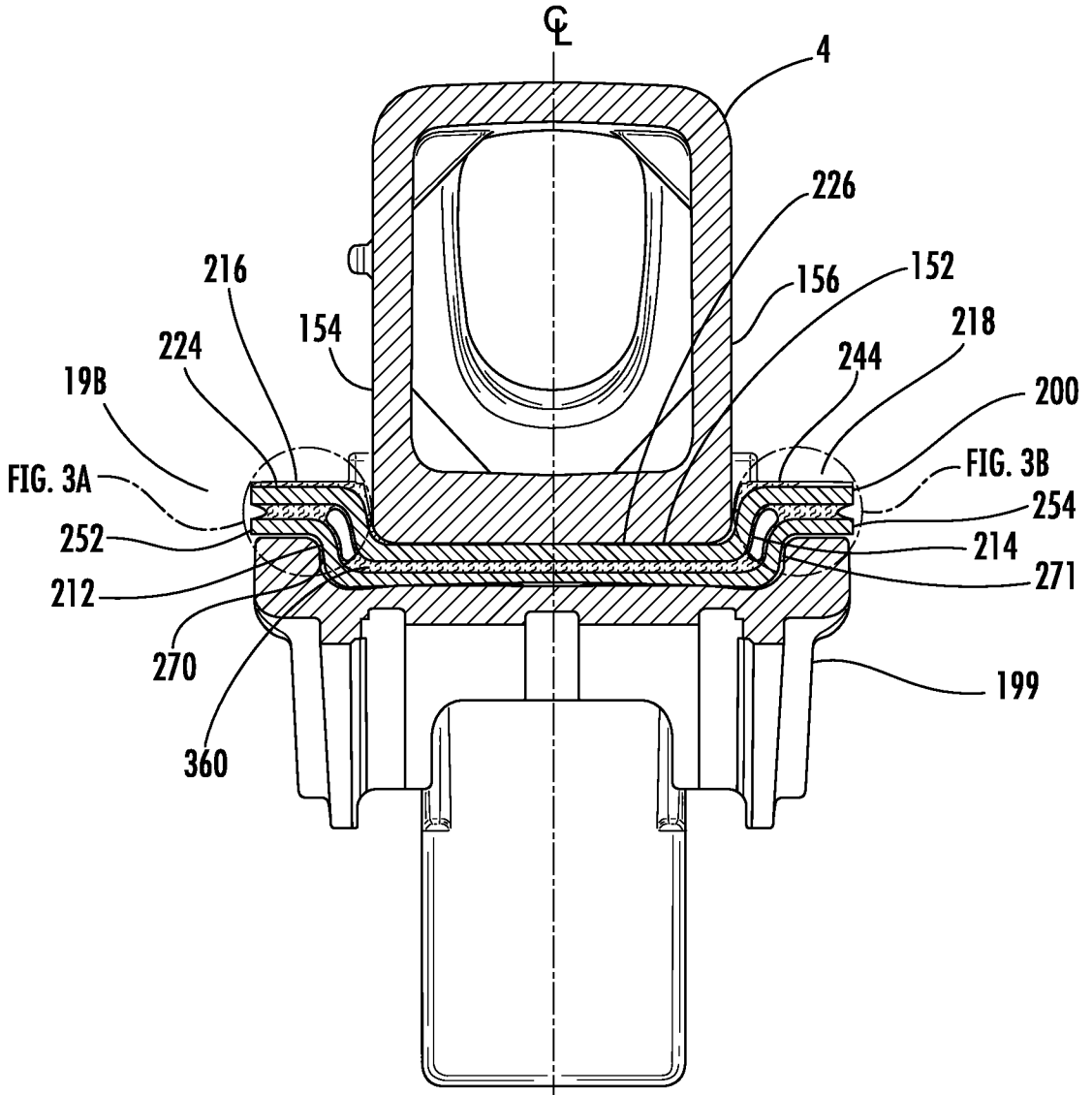
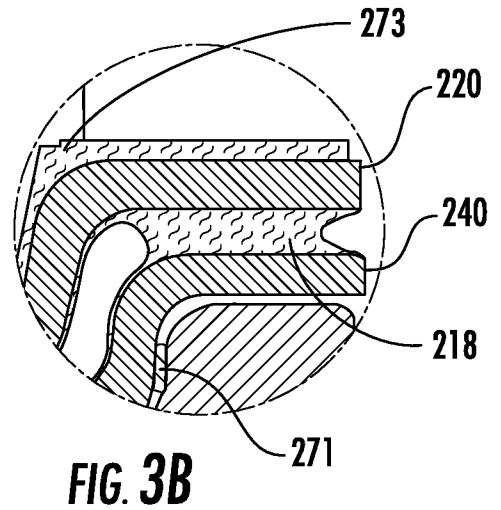
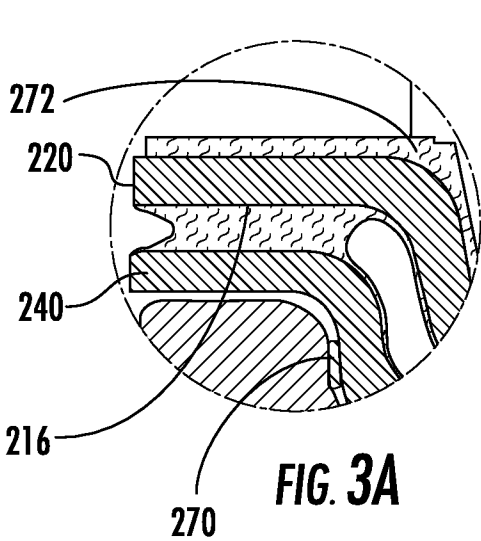

FIG. 3



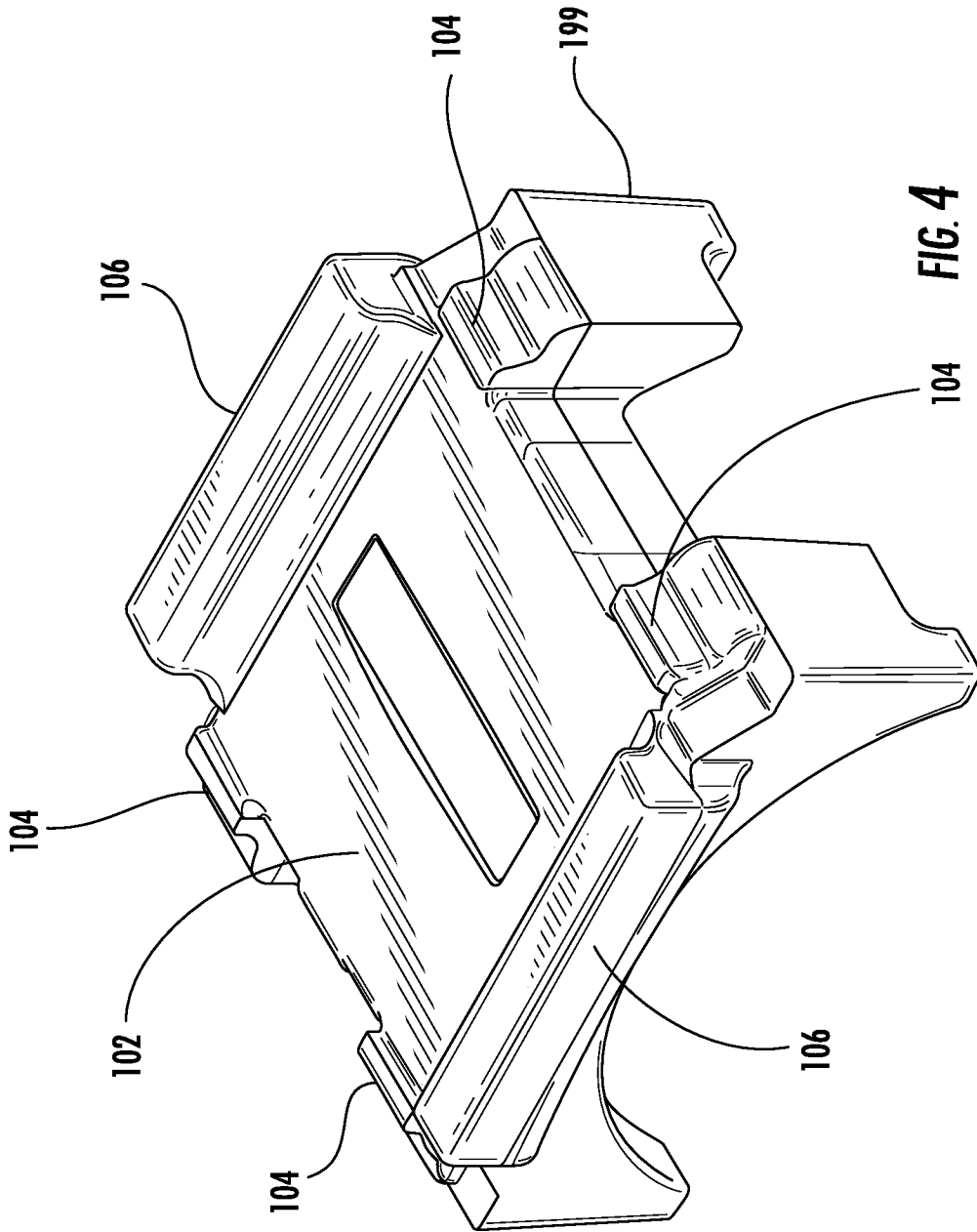

FIG. 4

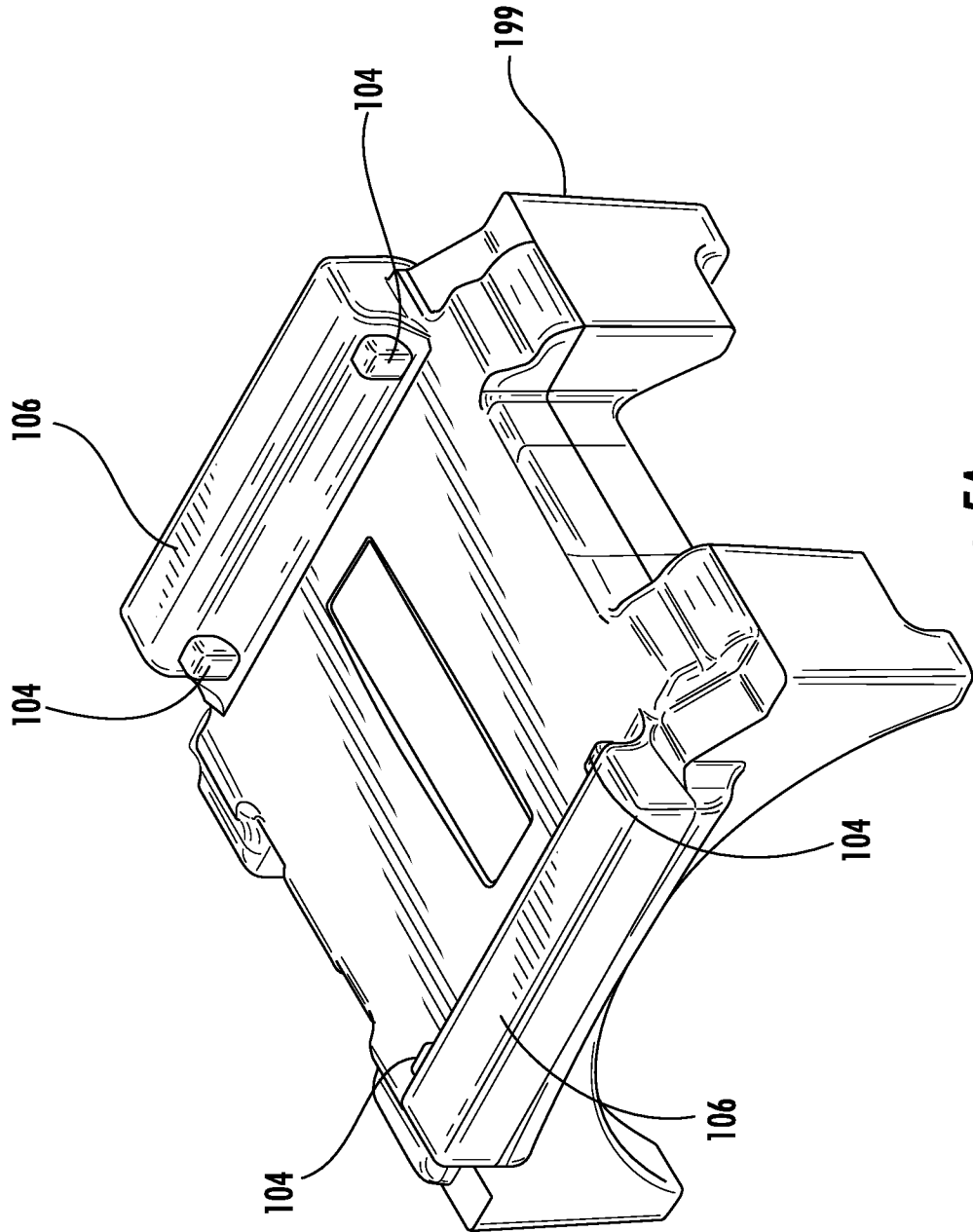

FIG. 5A

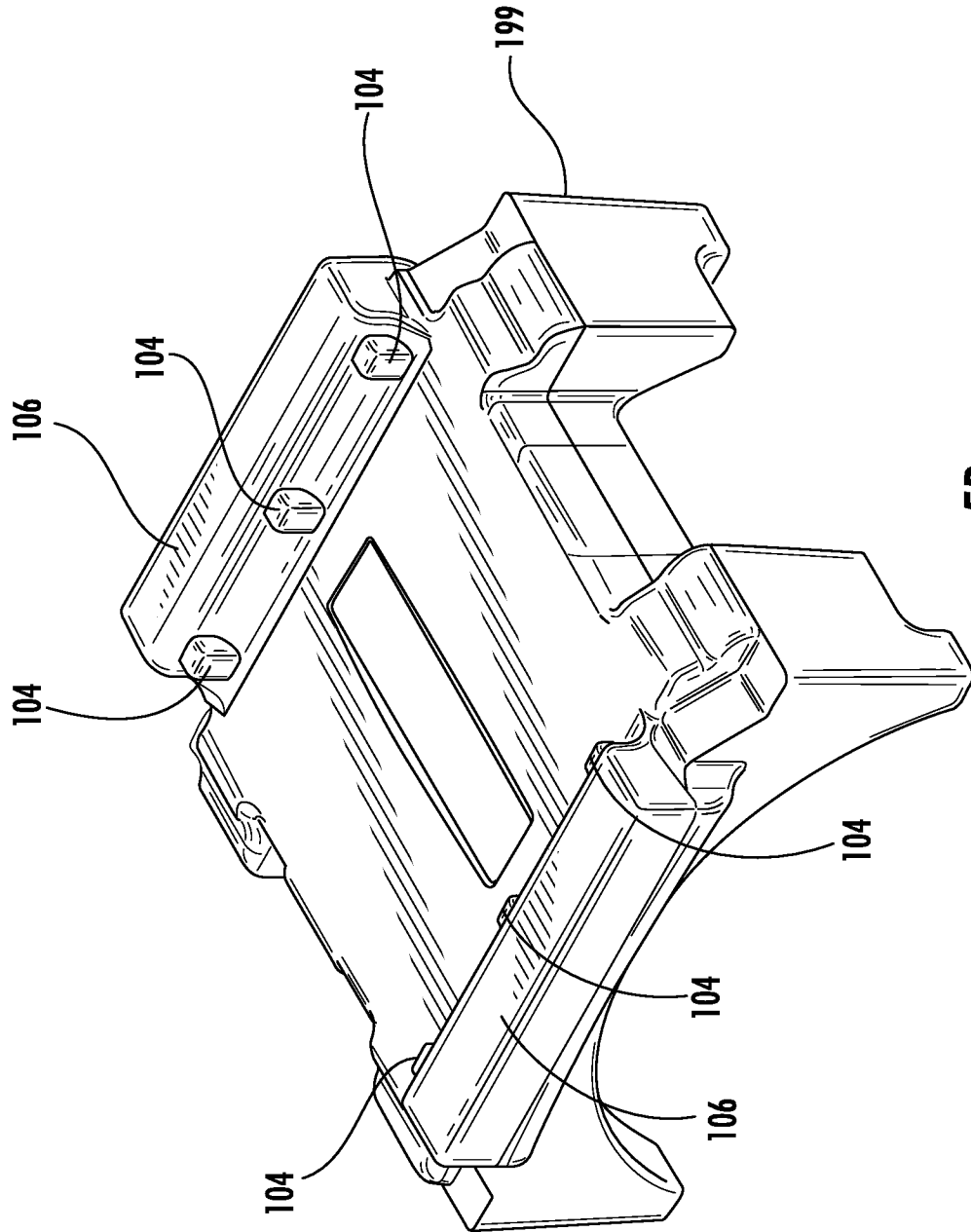

FIG. 5B

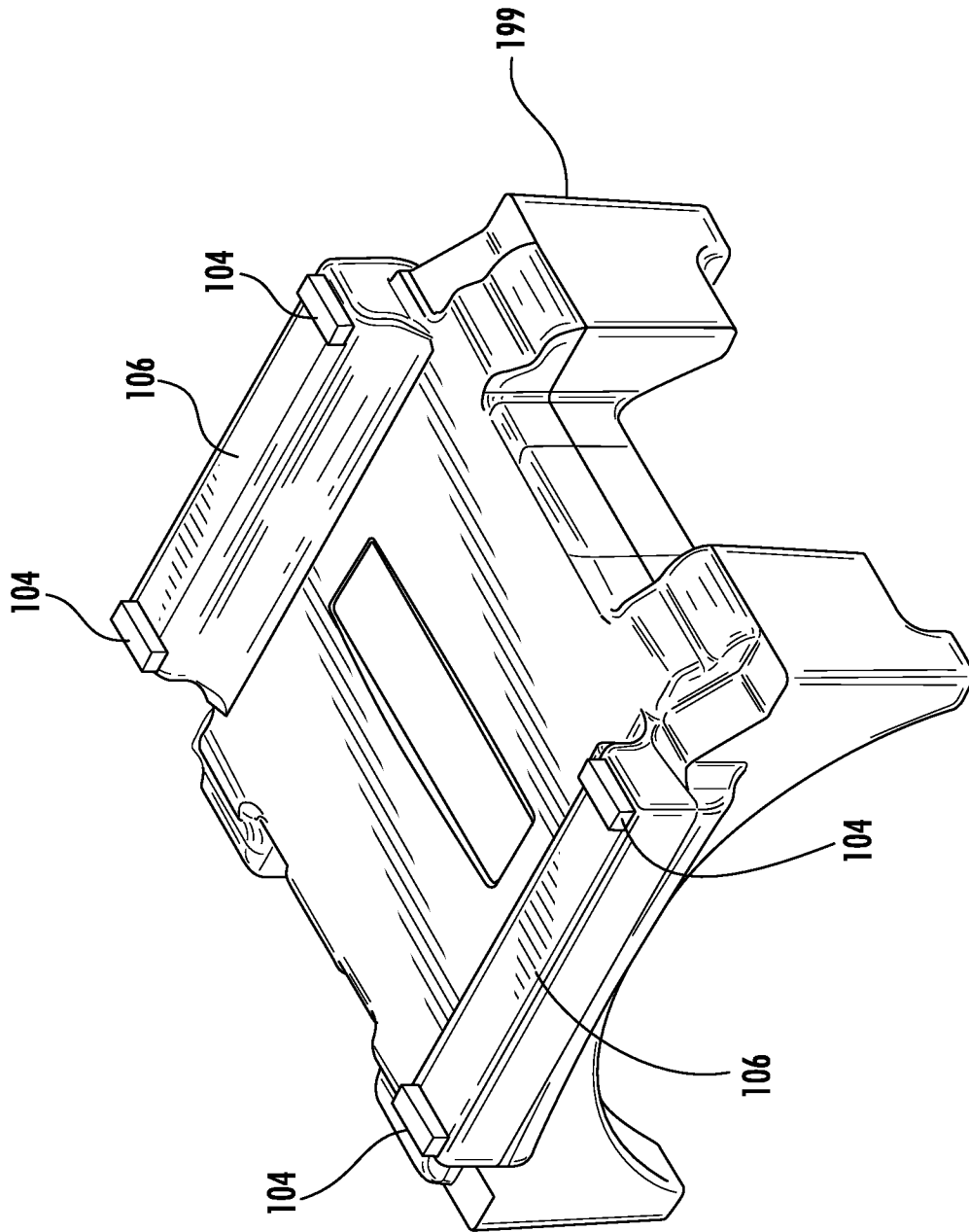

FIG. 5C

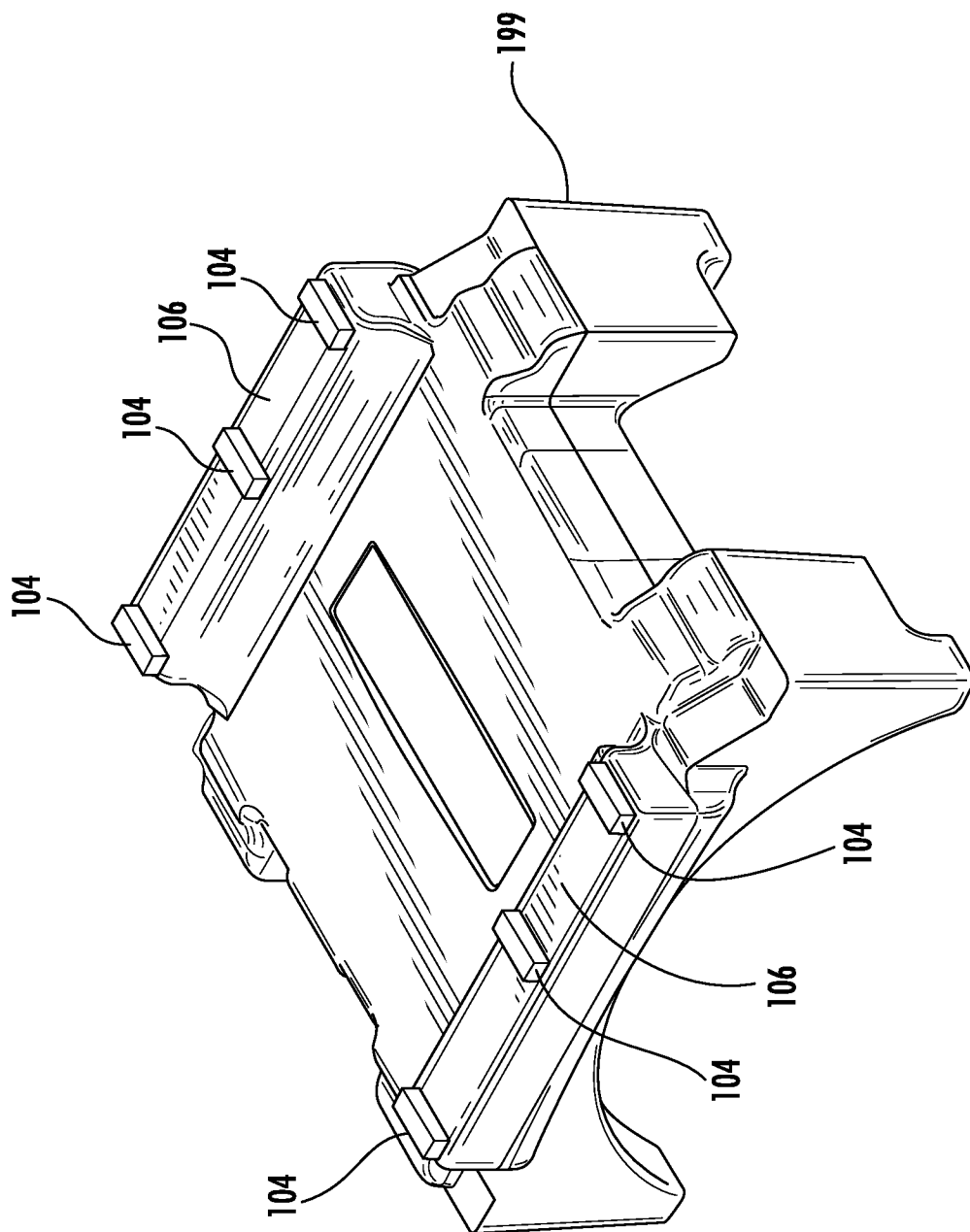

FIG. 5D

10/51

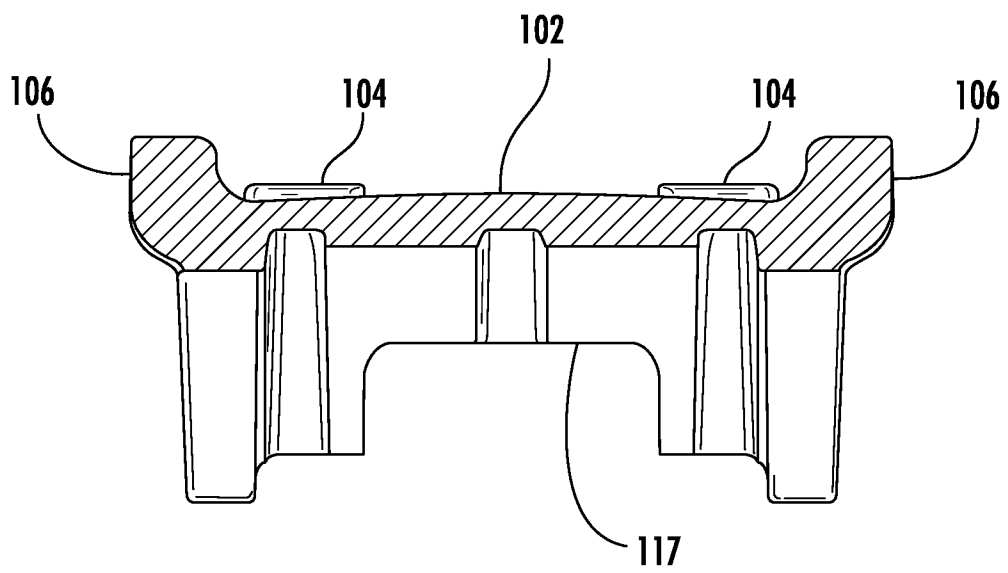

FIG. 6

11/51

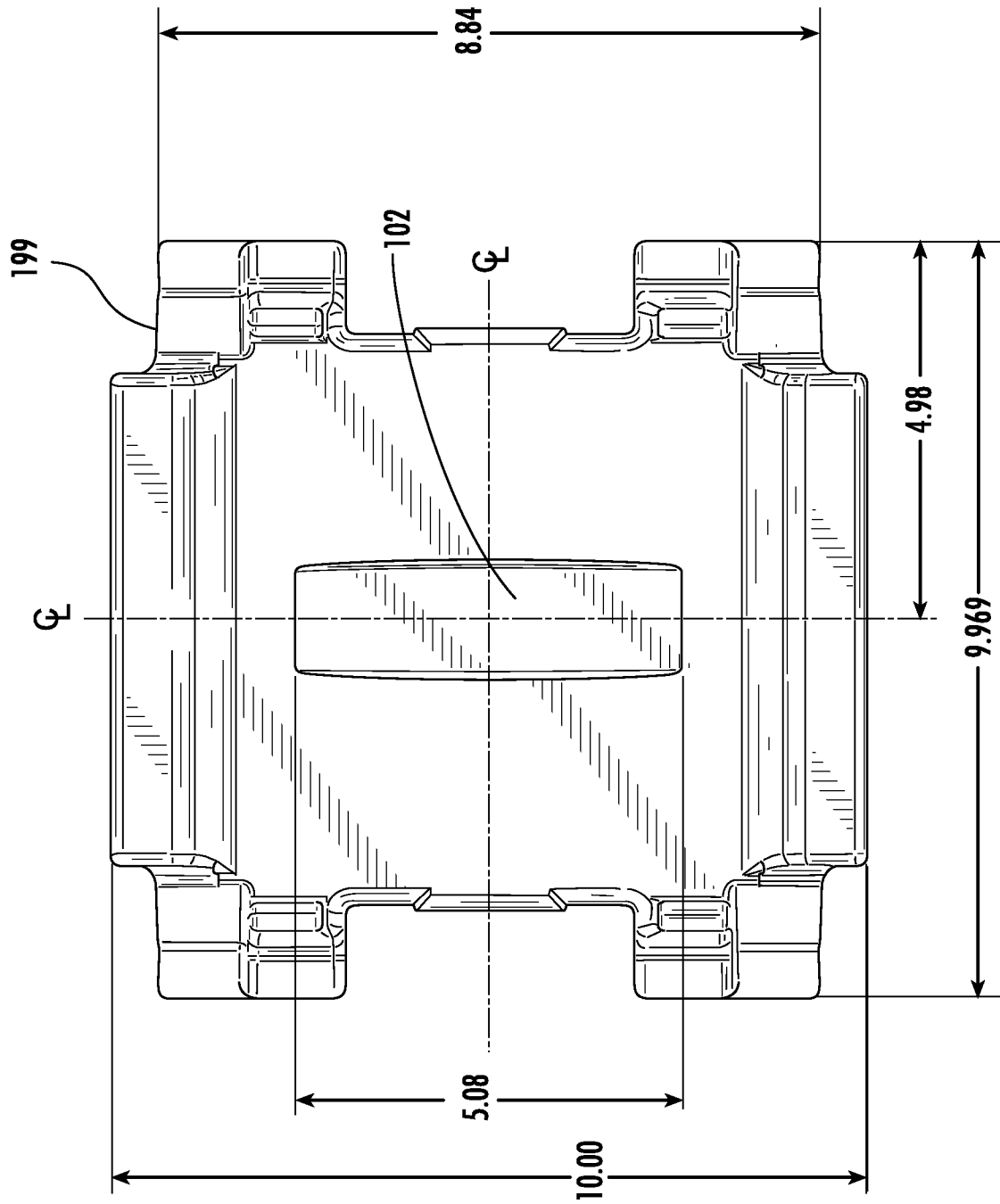

FIG. 7

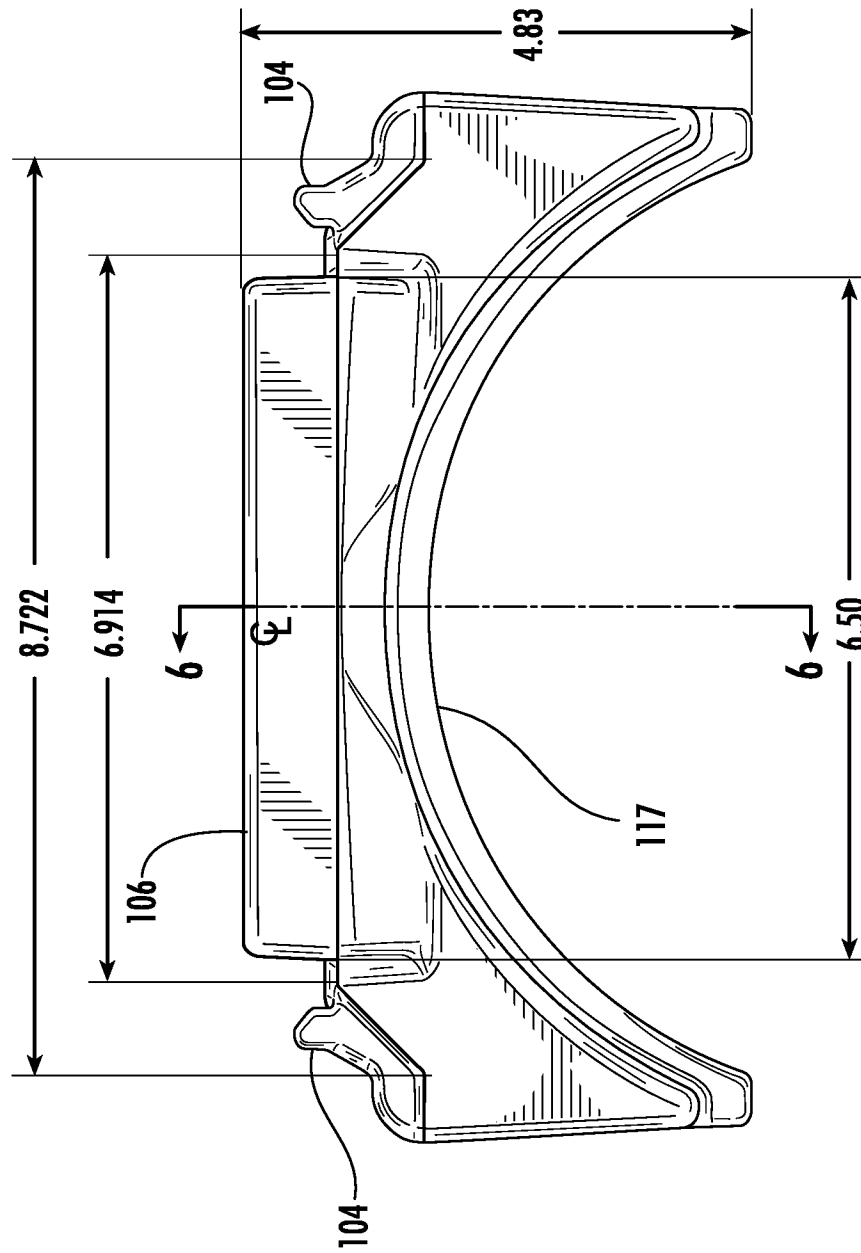

FIG. 8

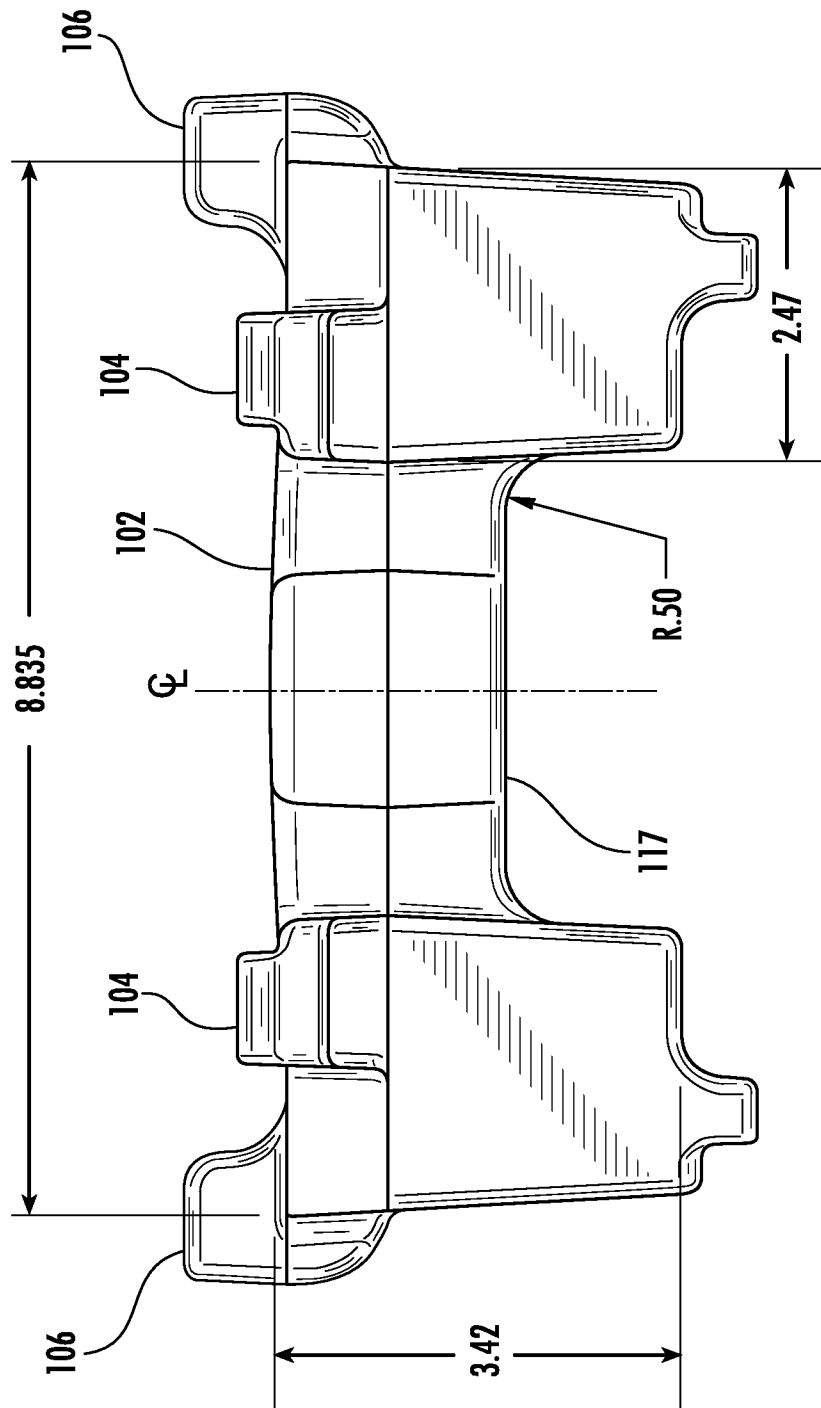
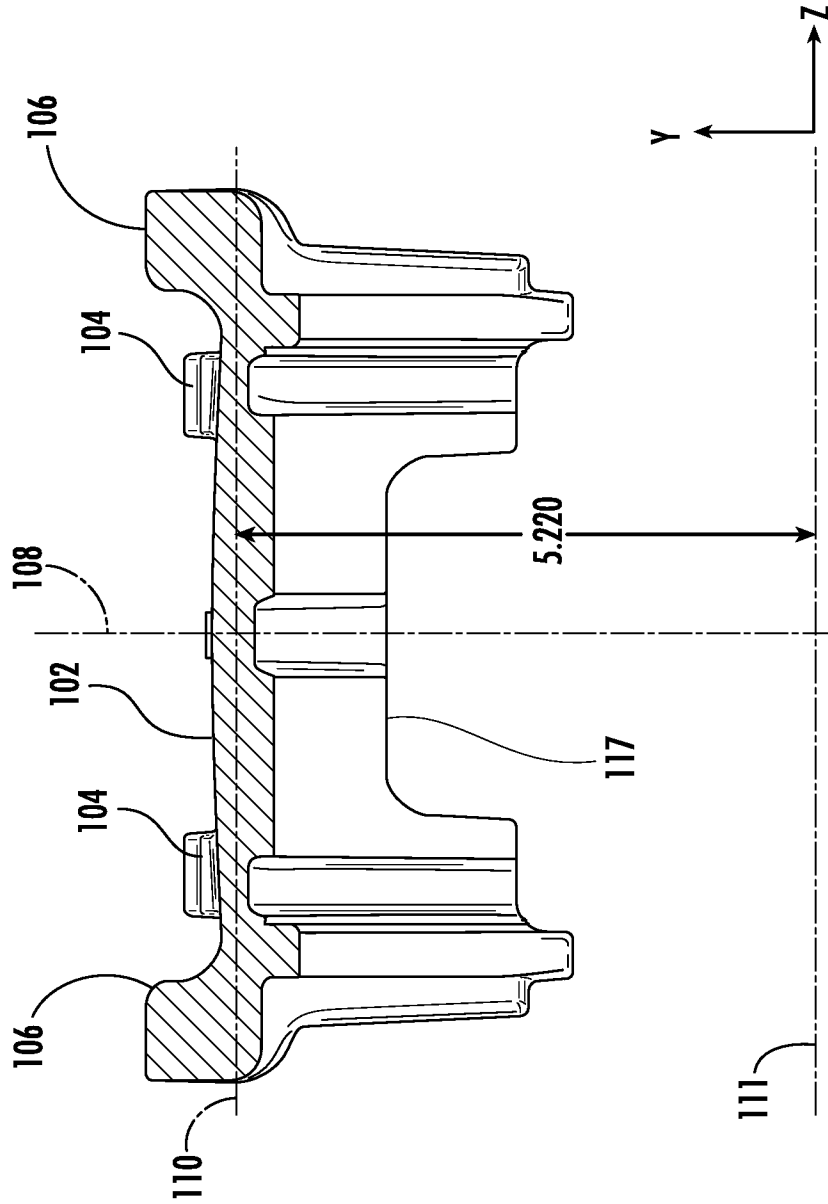
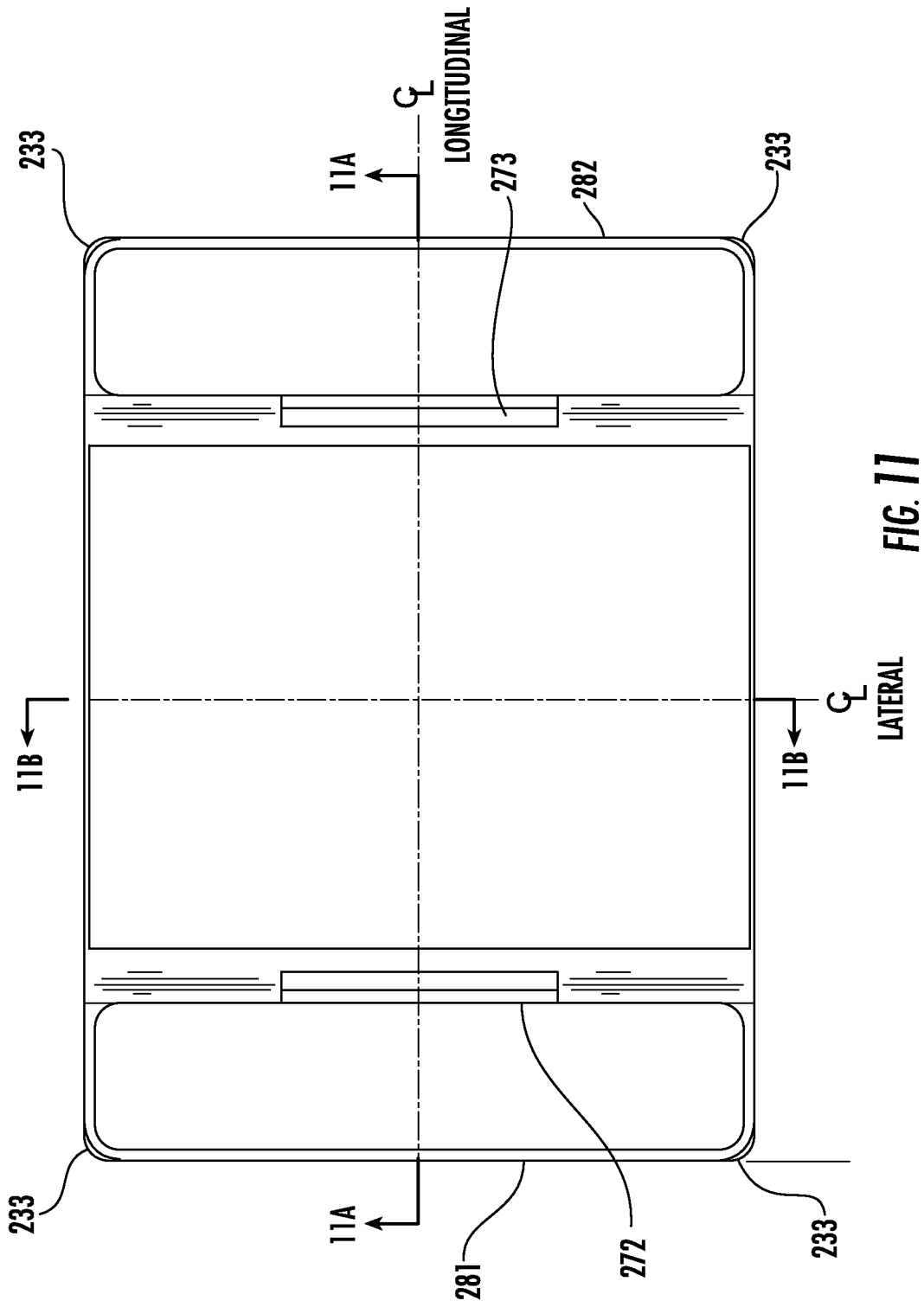

FIG. 9





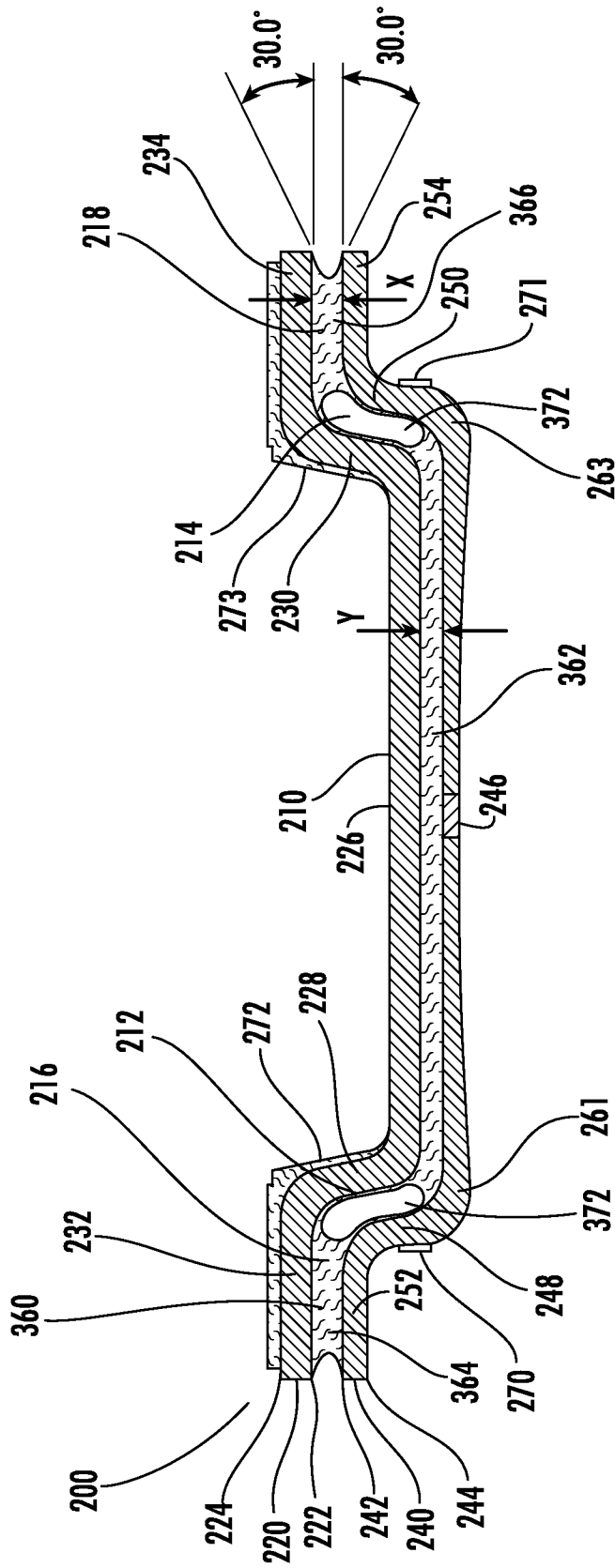

FIG. 11A

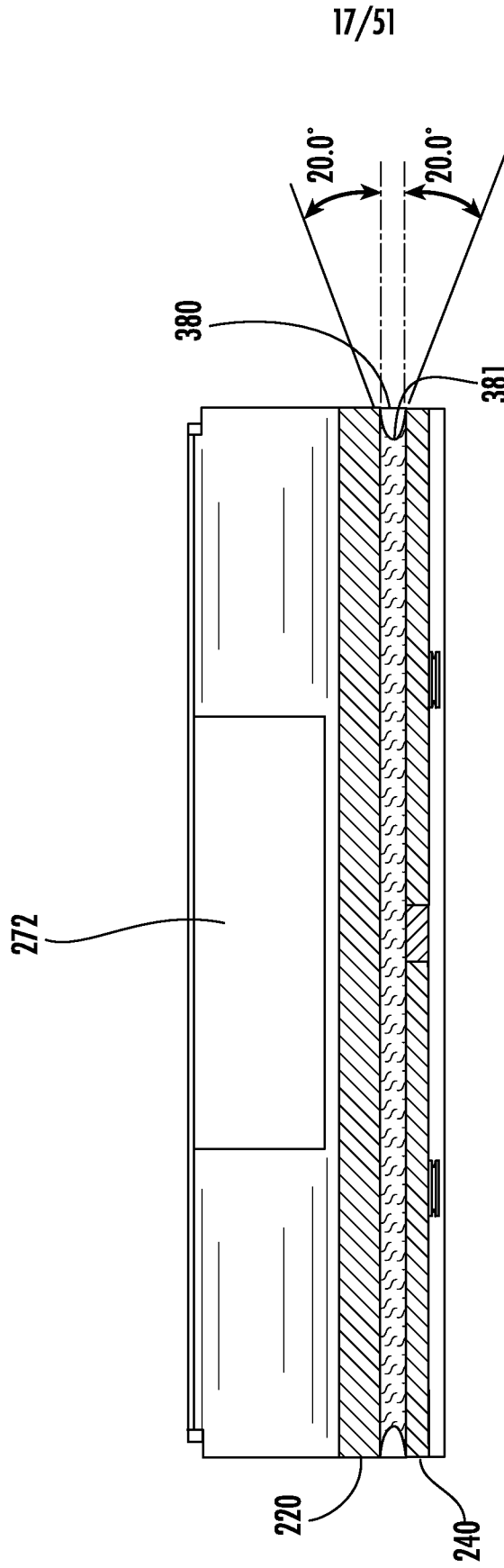

FIG. 17B

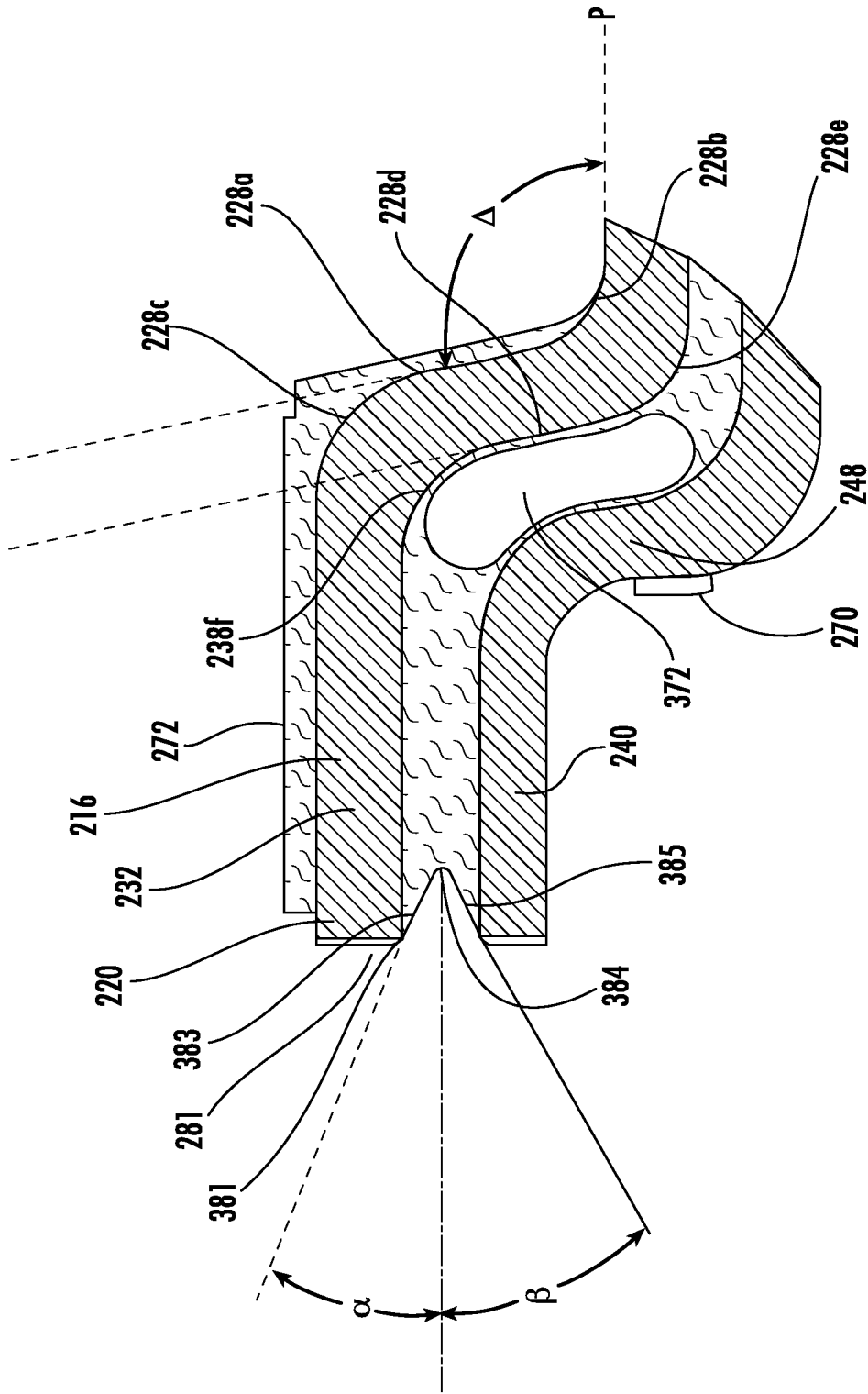

FIG. 11C

19/51

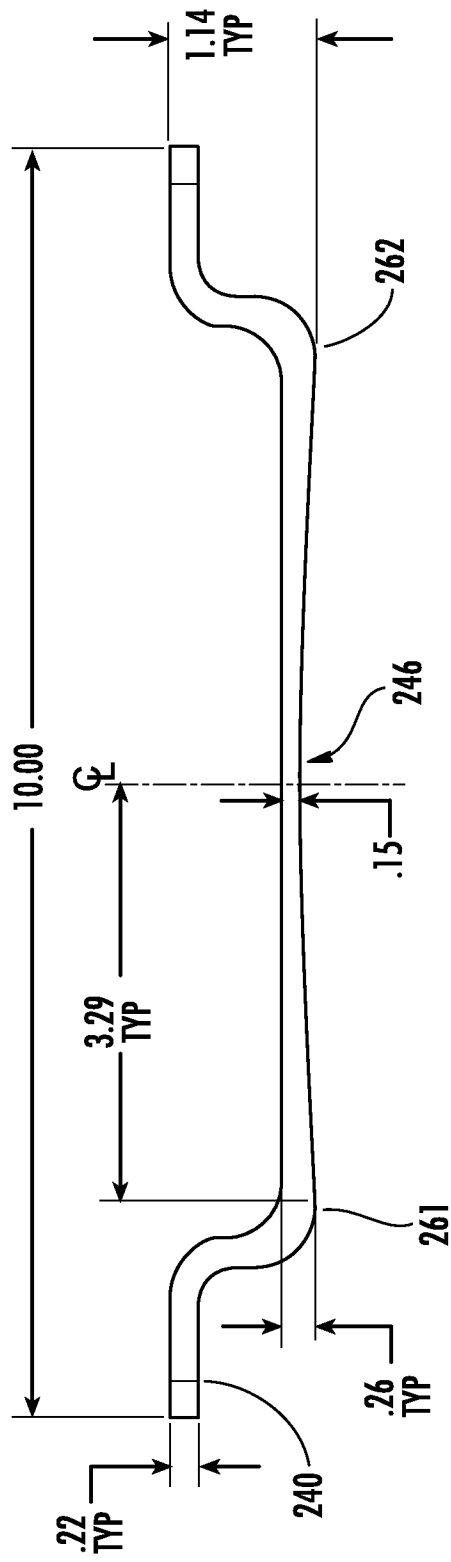

FIG. 12

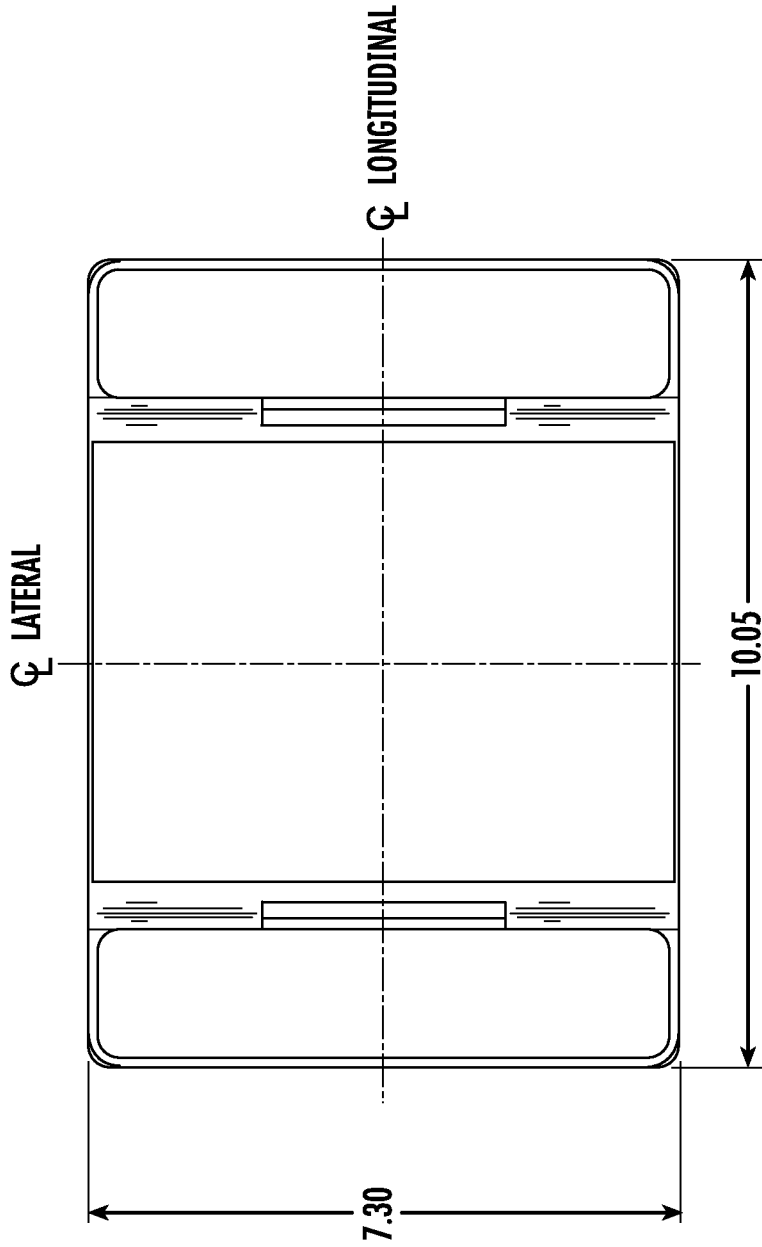

FIG. 13A

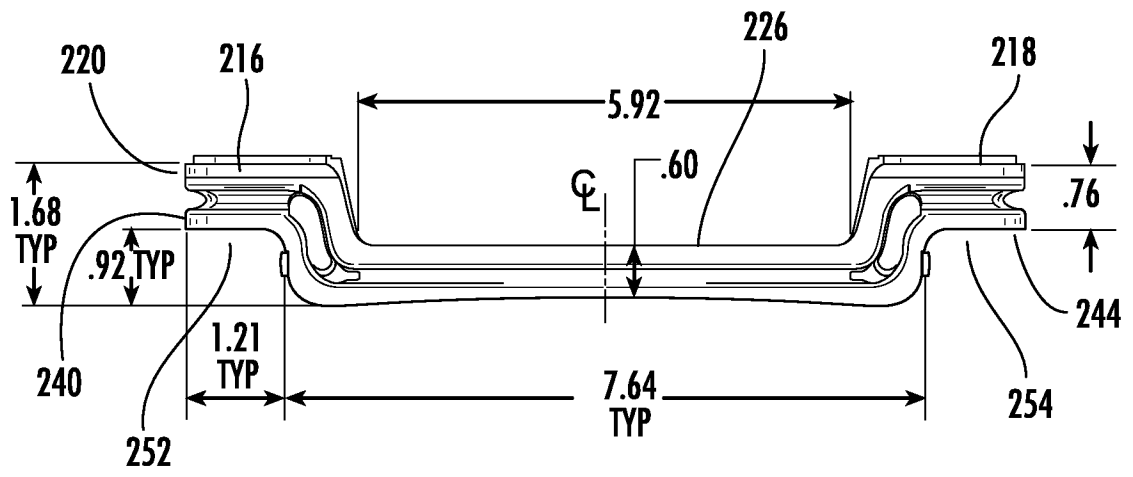

FIG. 13B

22/51

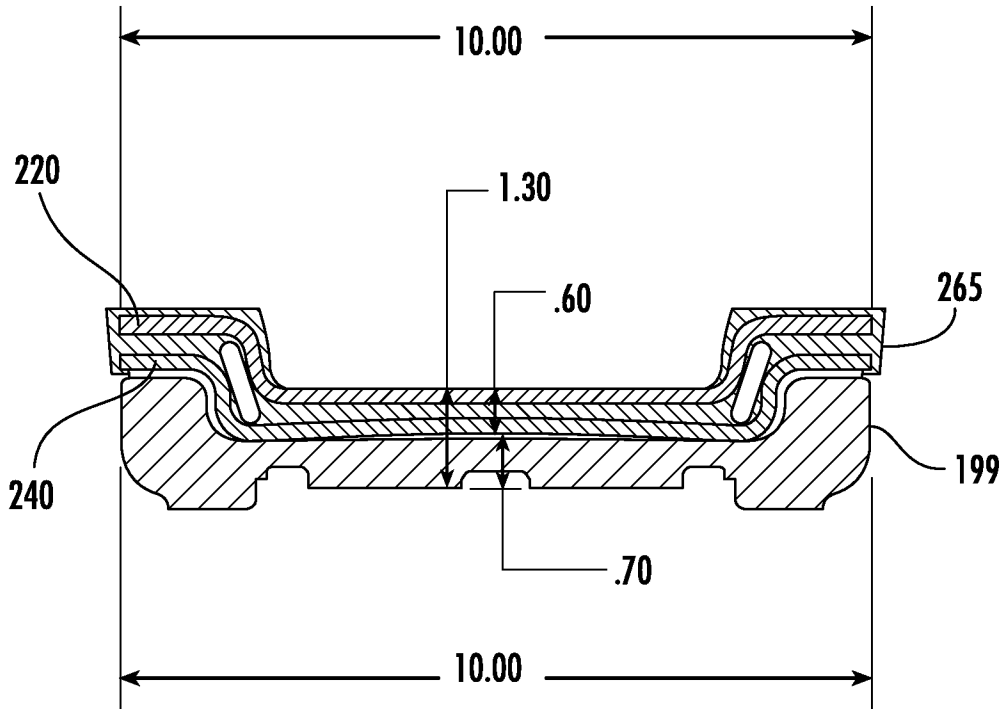
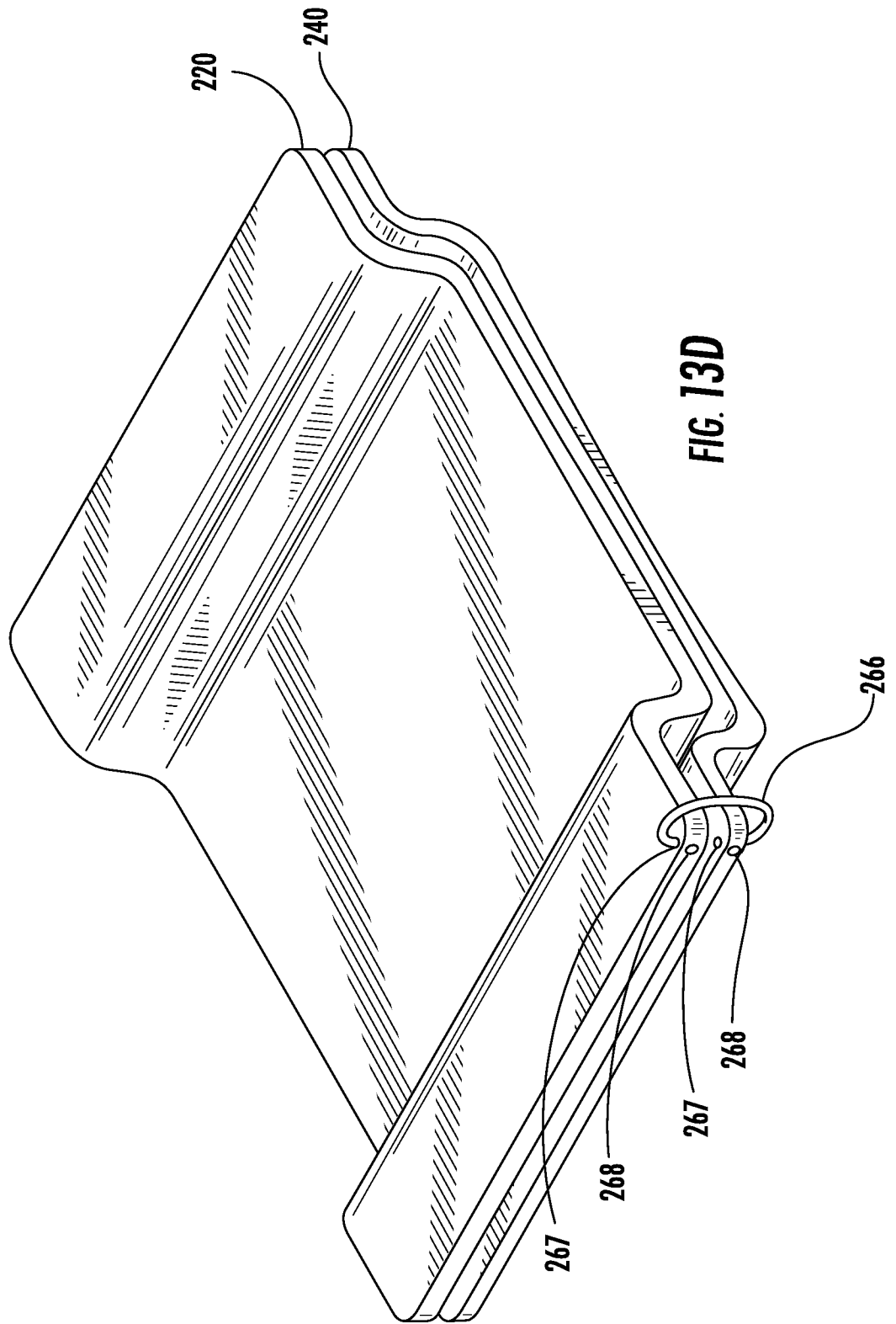
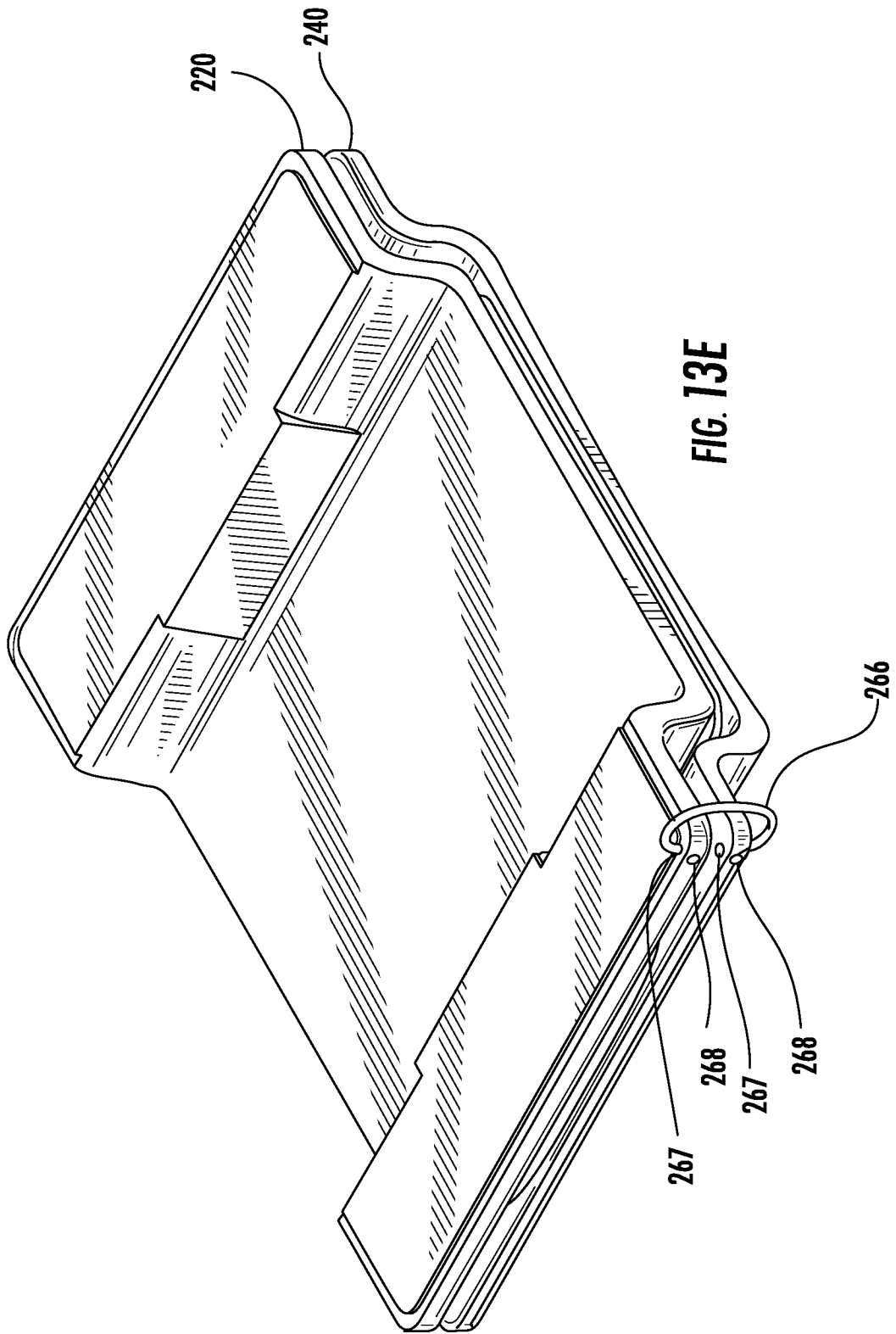

FIG. 13C

23/51



24/51



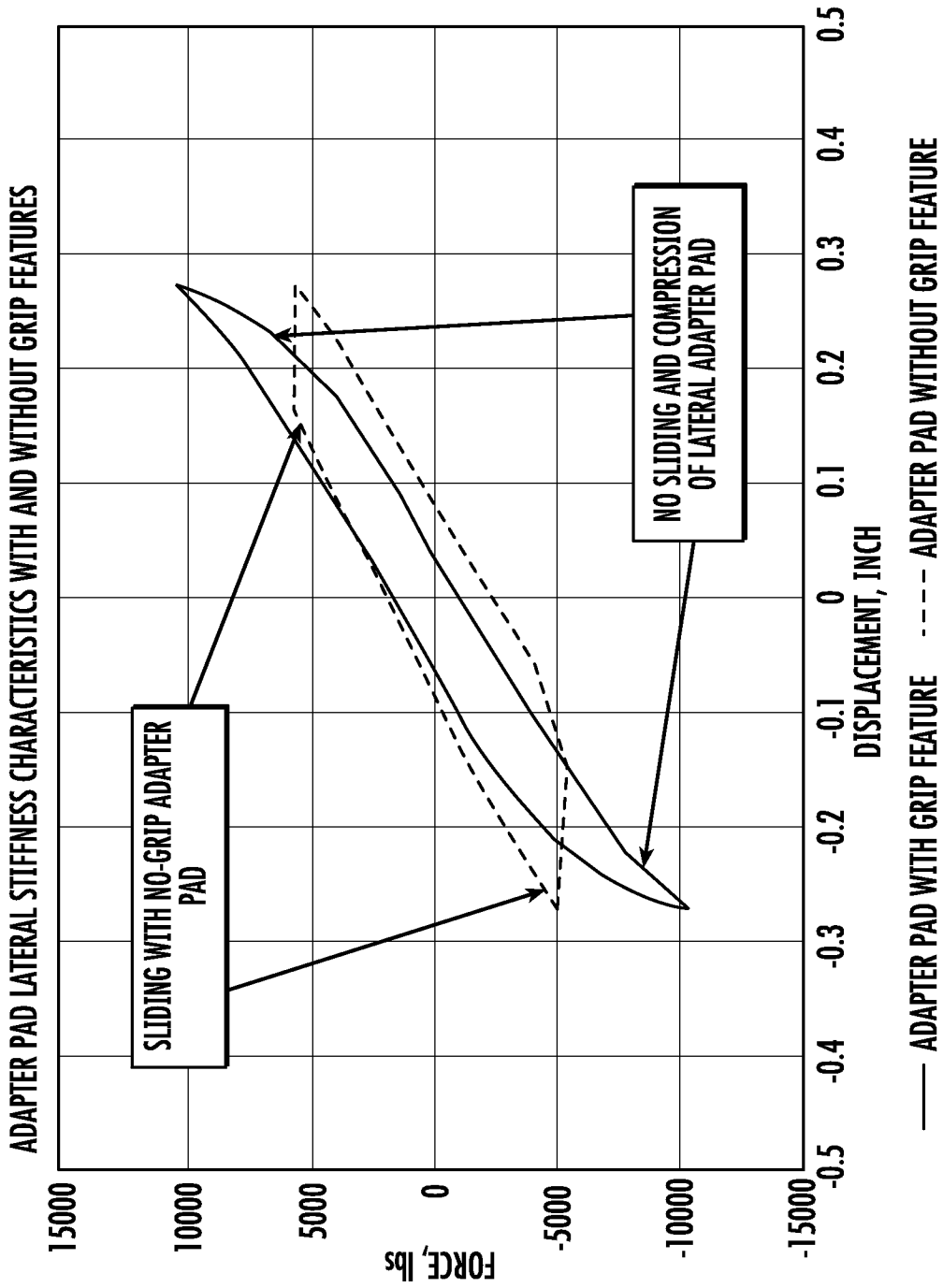

FIG. 14

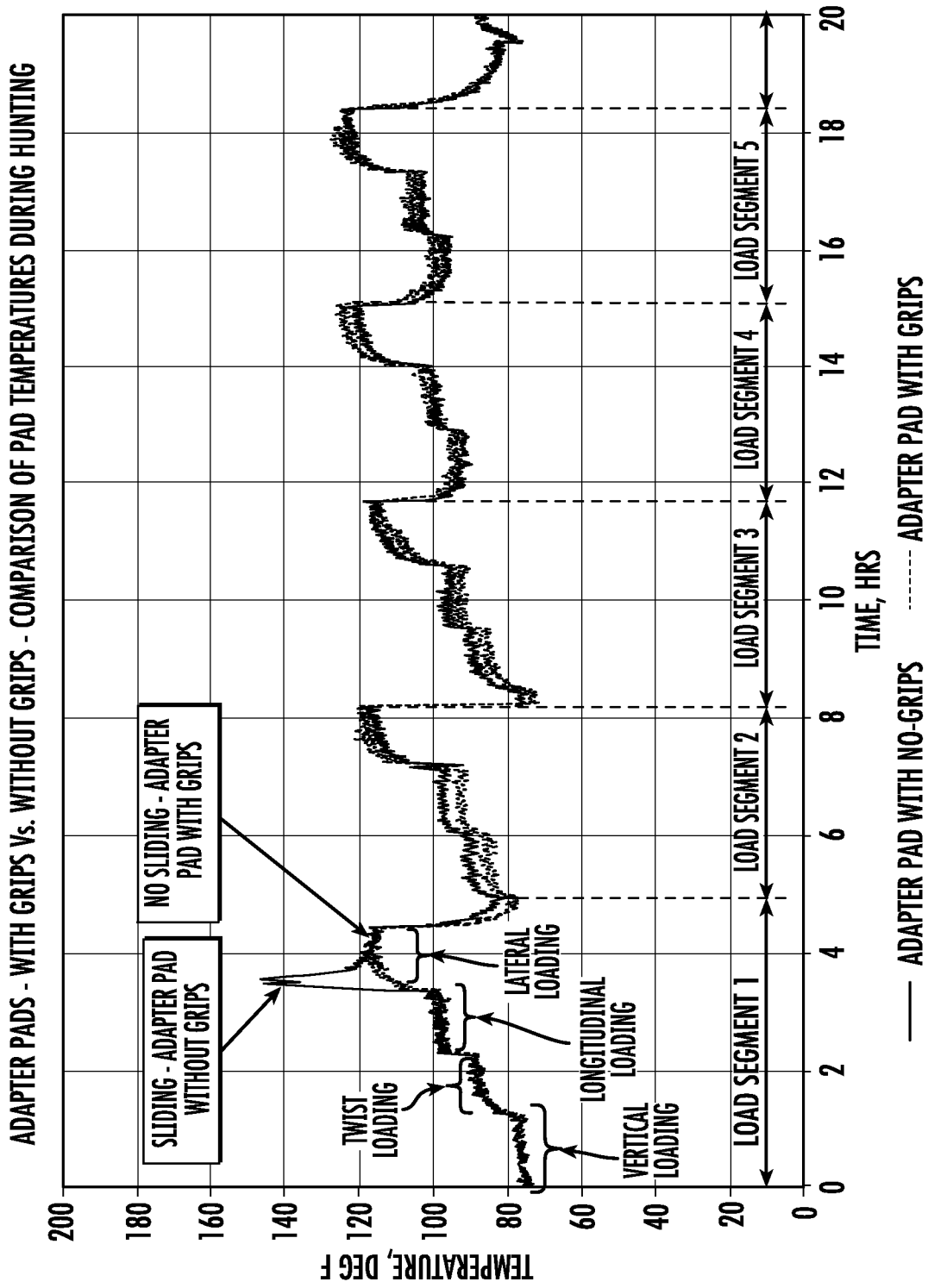

FIG. 15

27/51

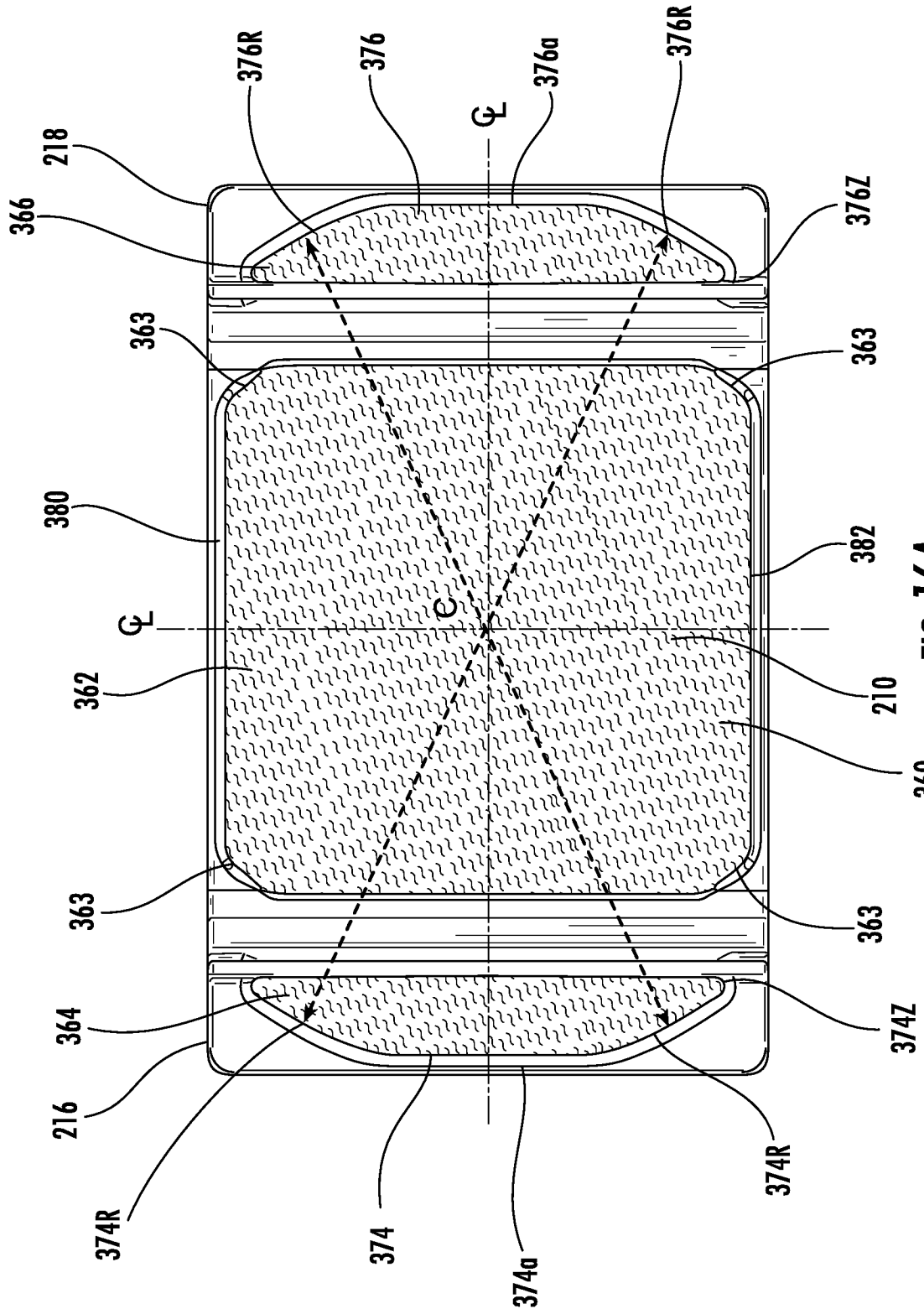

FIG. 16A

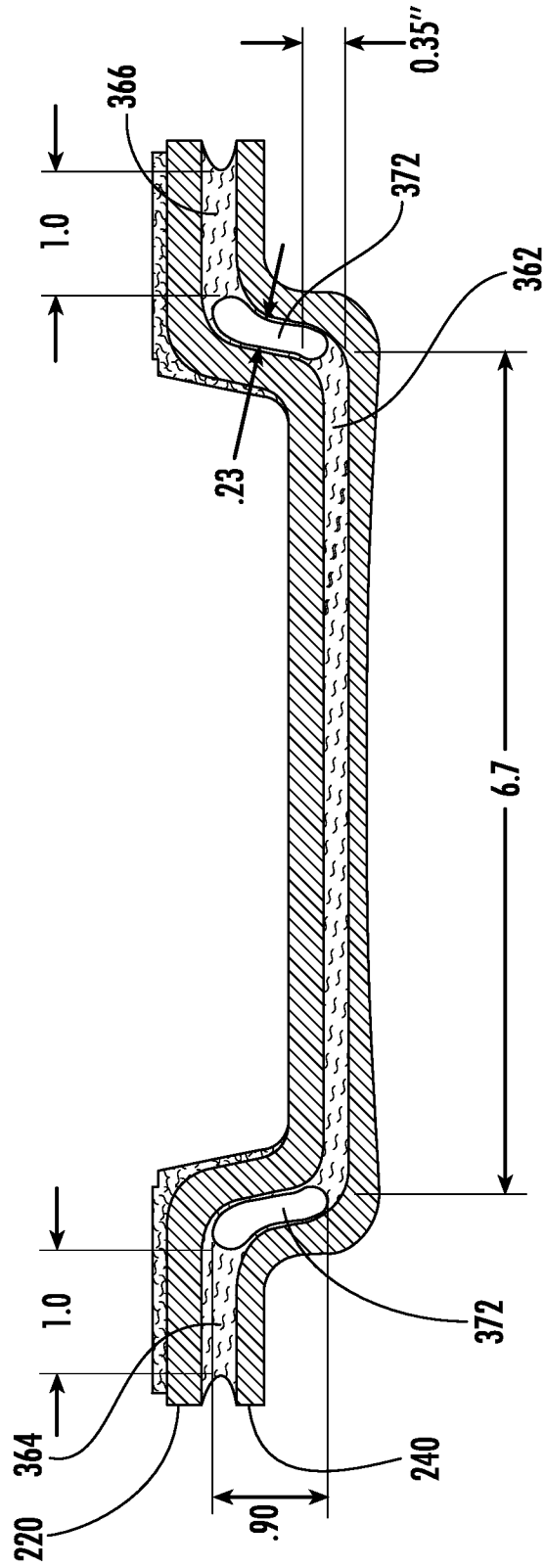

FIG. 16B

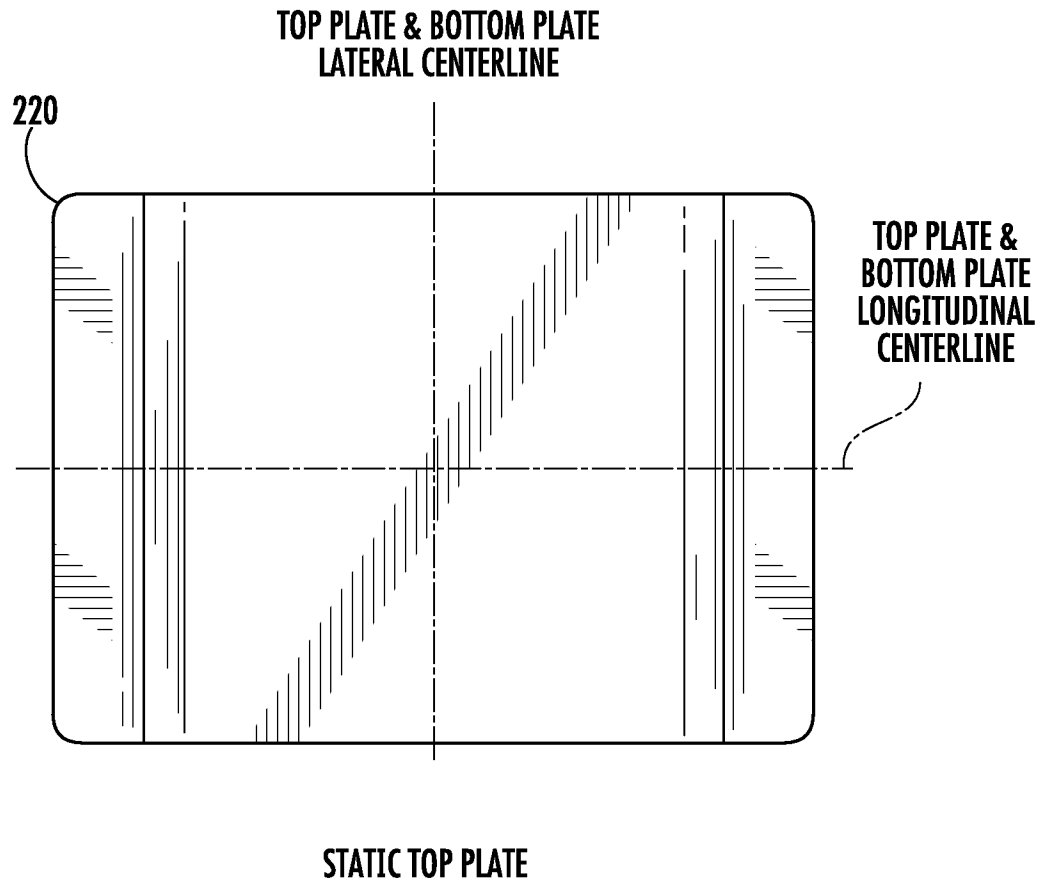

FIG. 17A

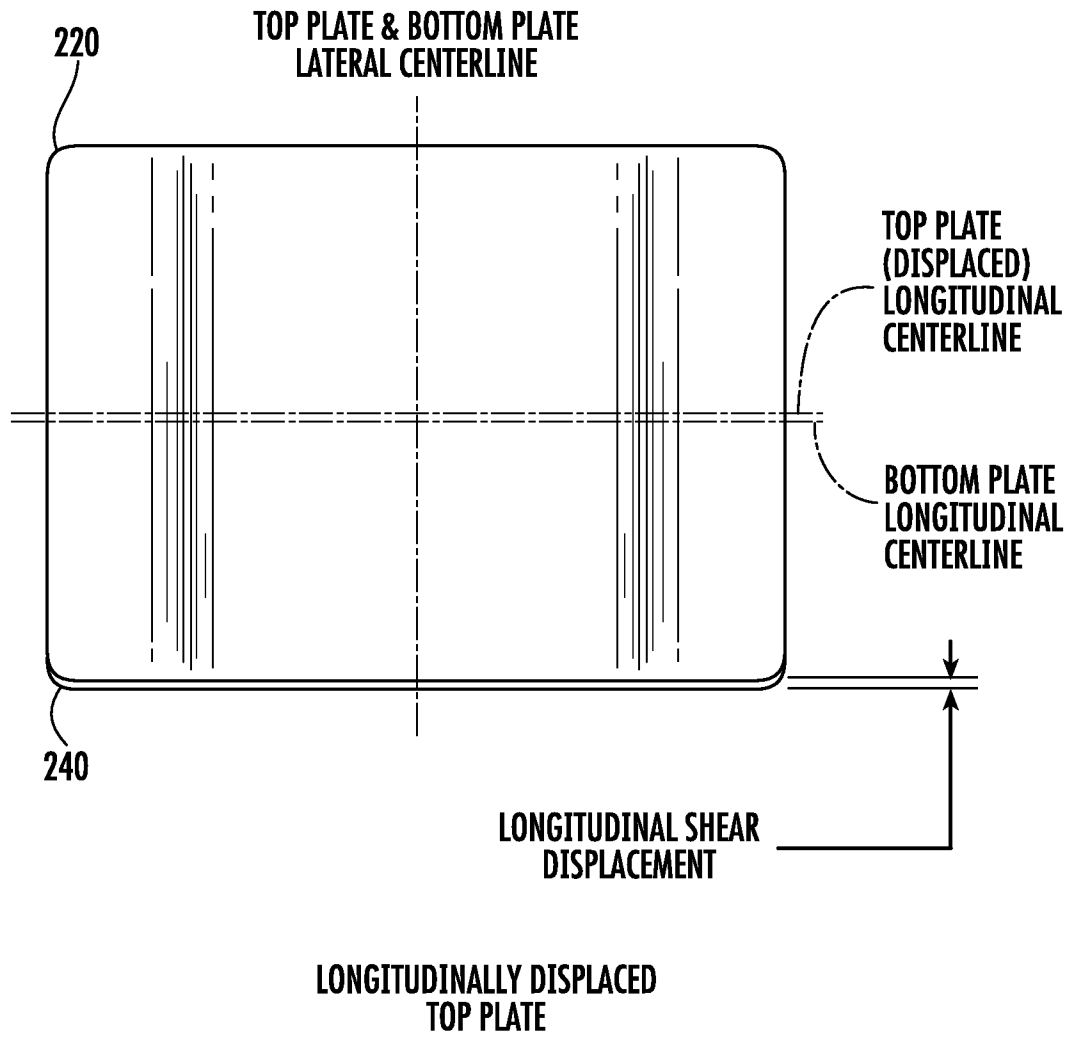

FIG. 17B

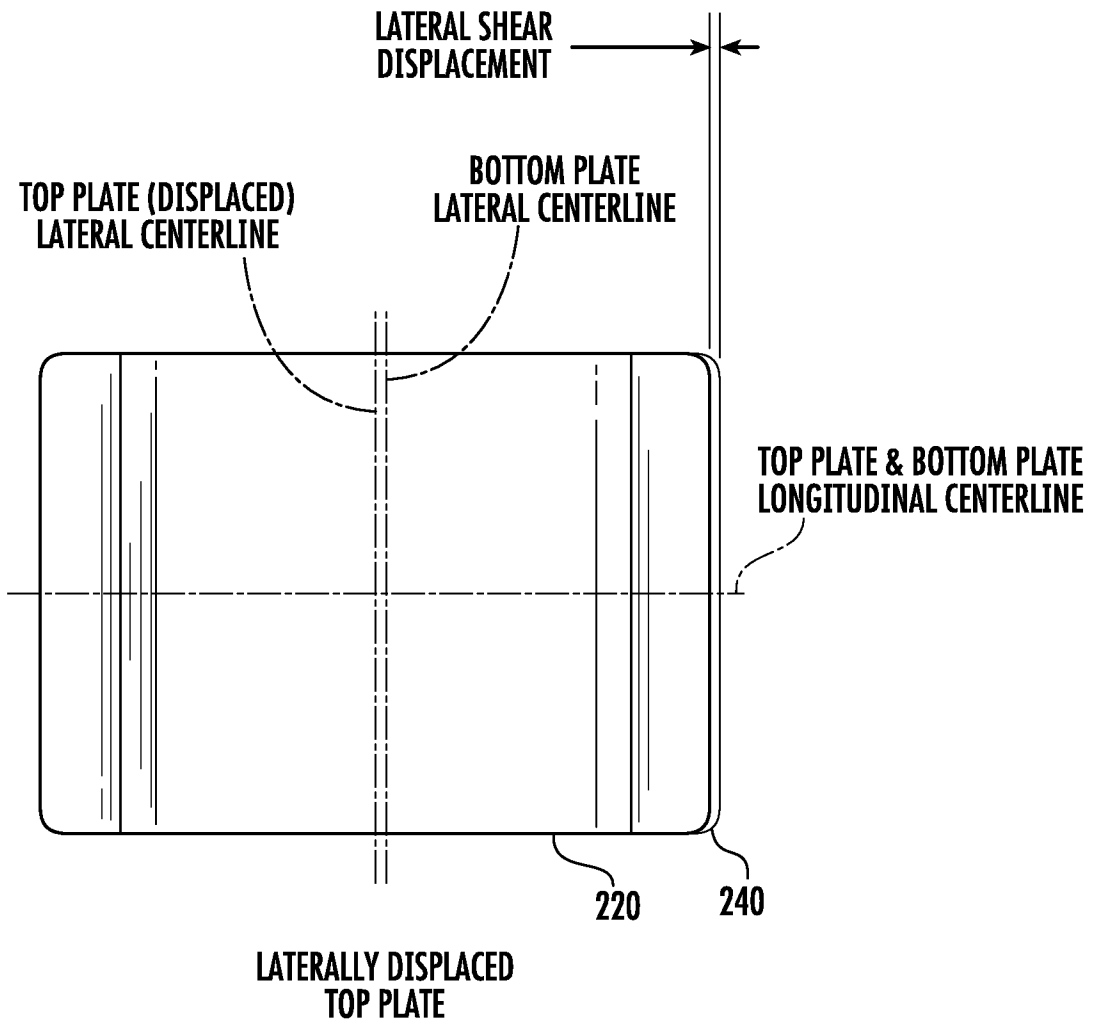

FIG. 17C

32/51

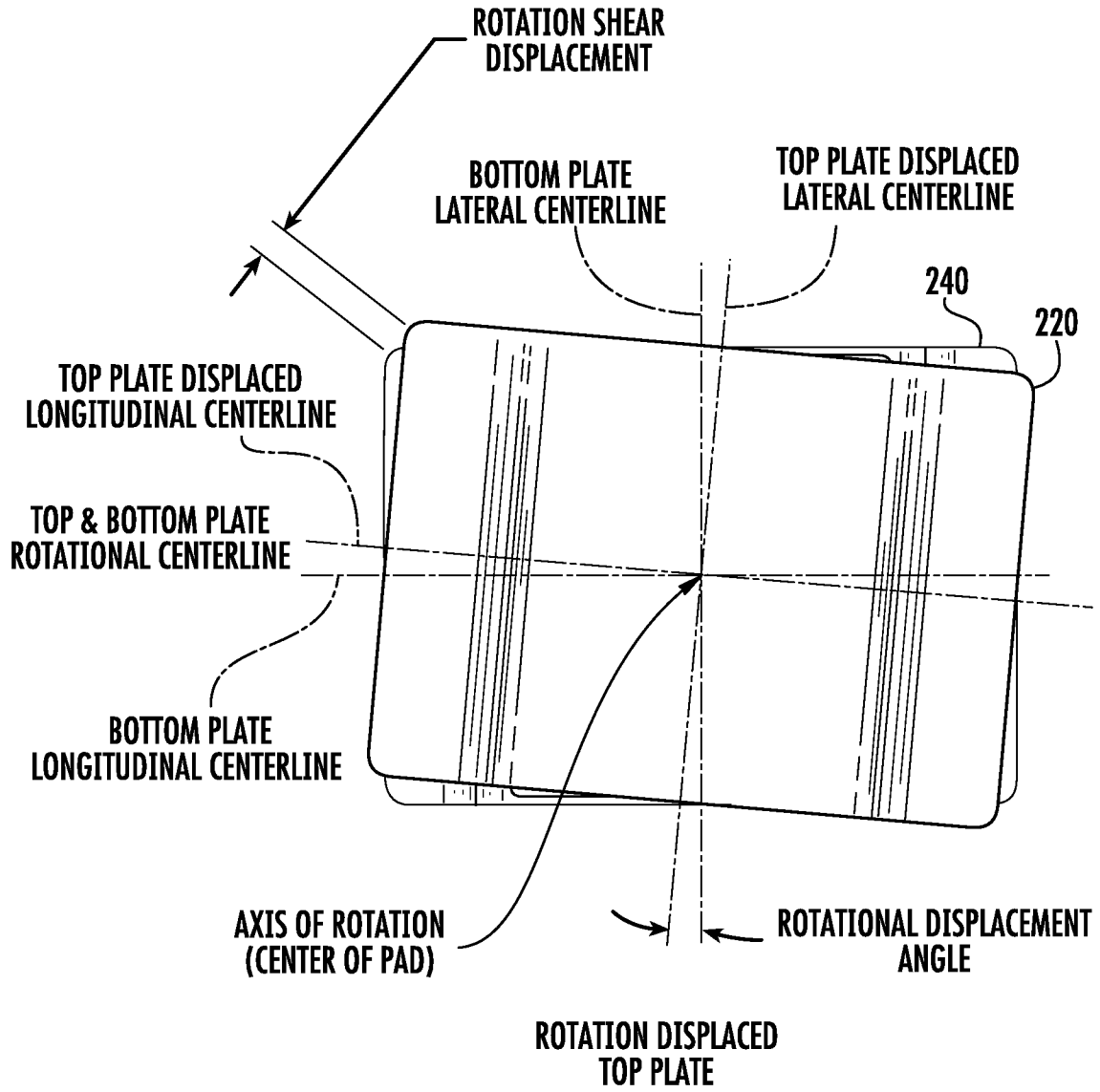

FIG. 17D

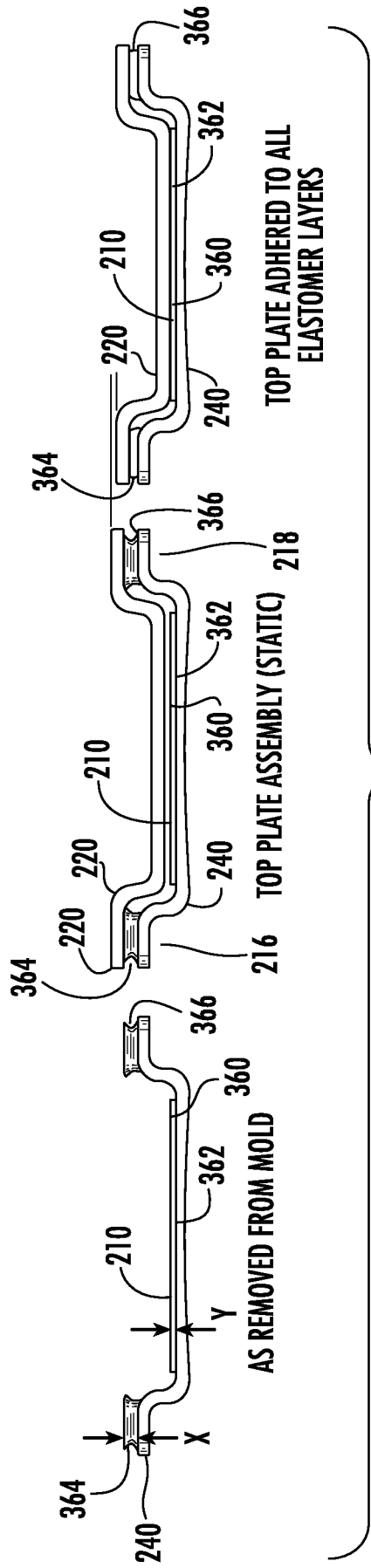

FIG. 18

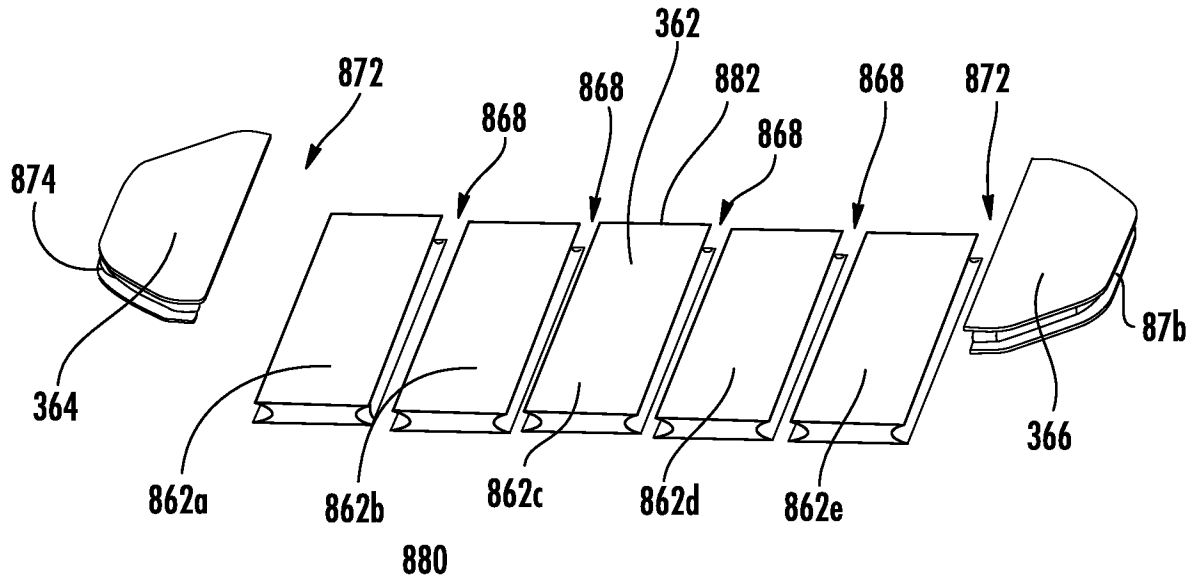

FIG. 19

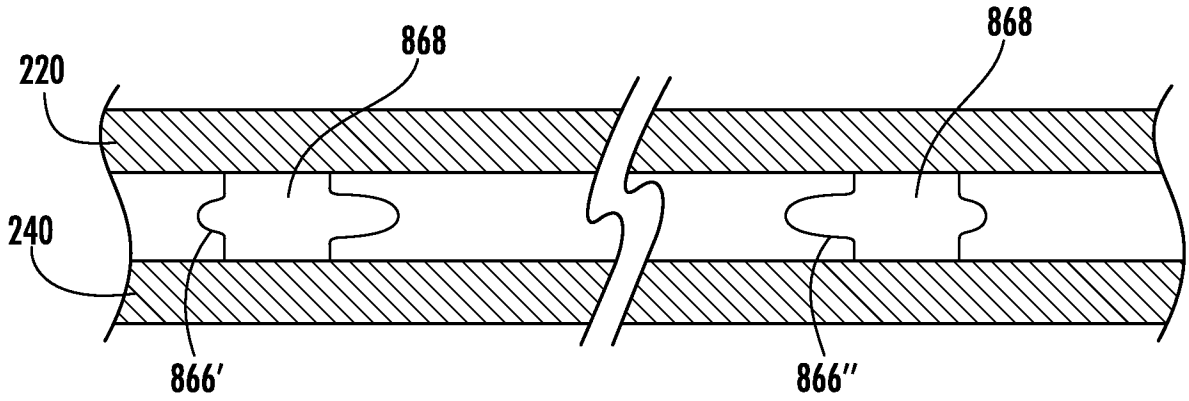

FIG. 20A

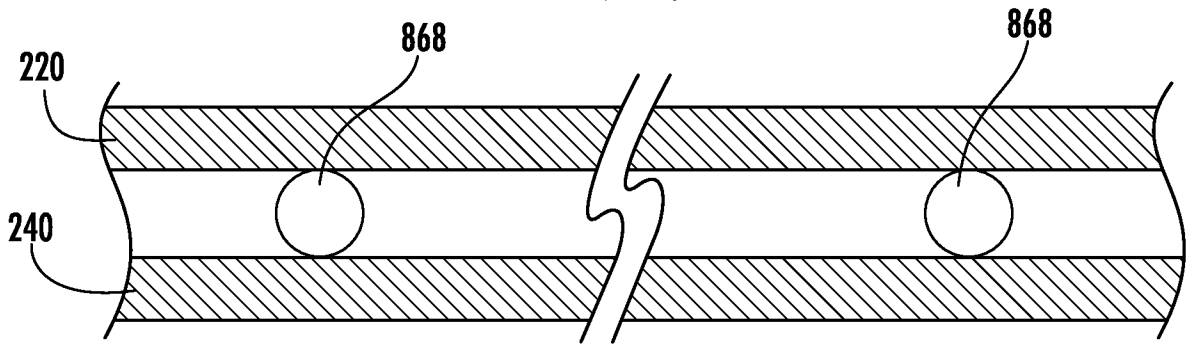

FIG. 20B

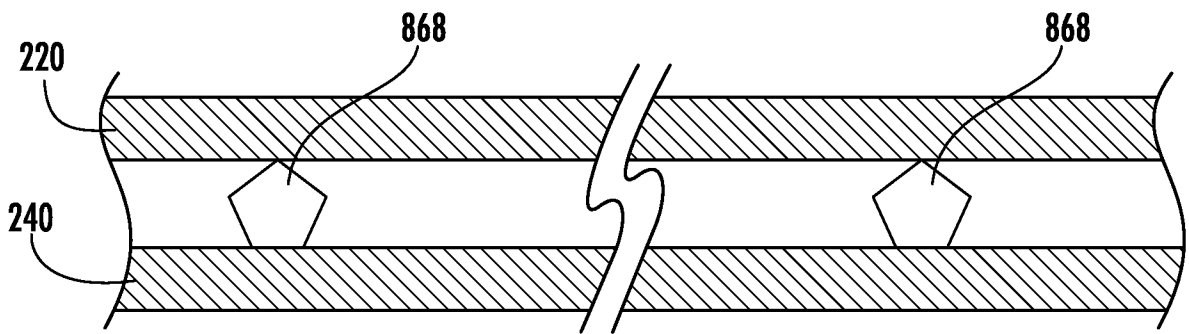
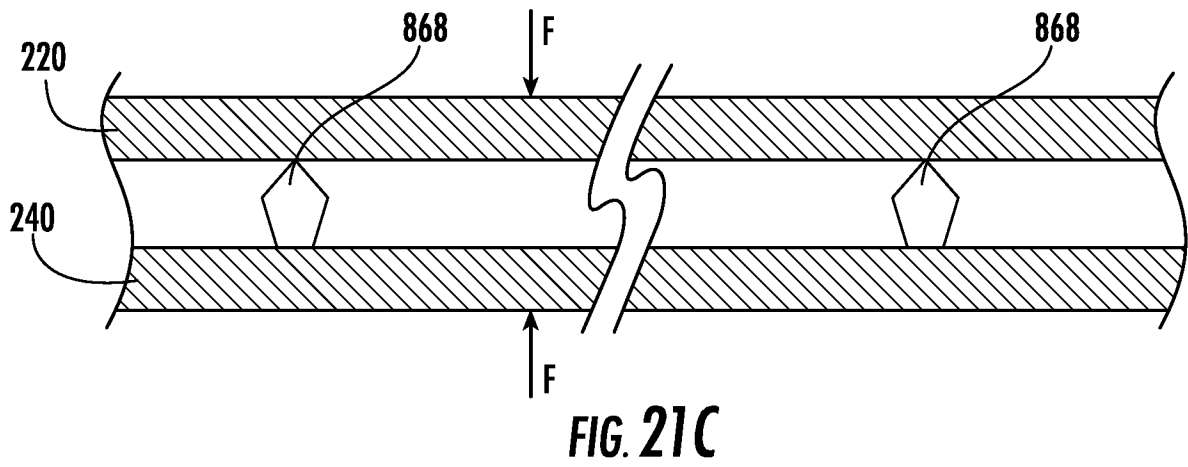
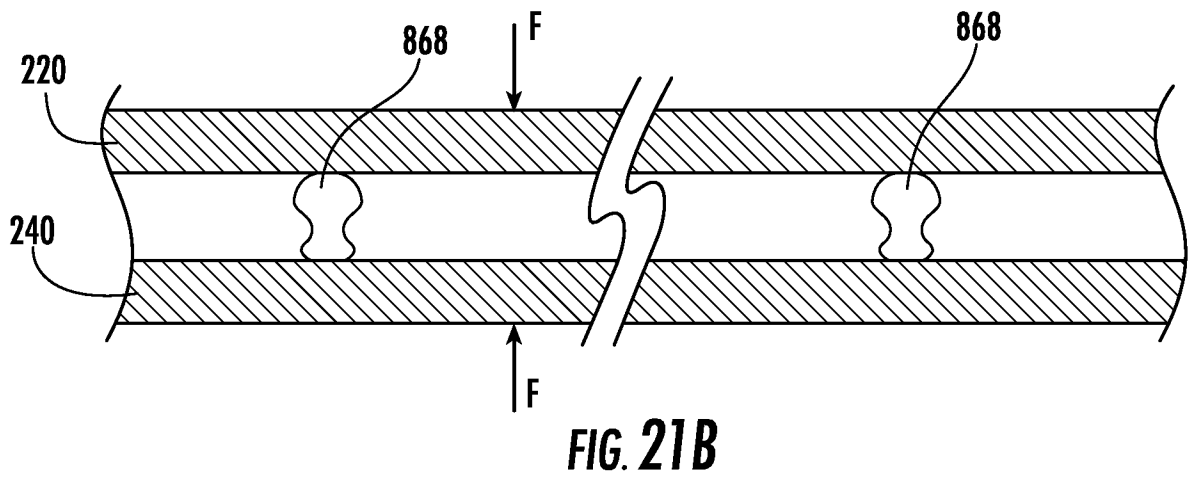
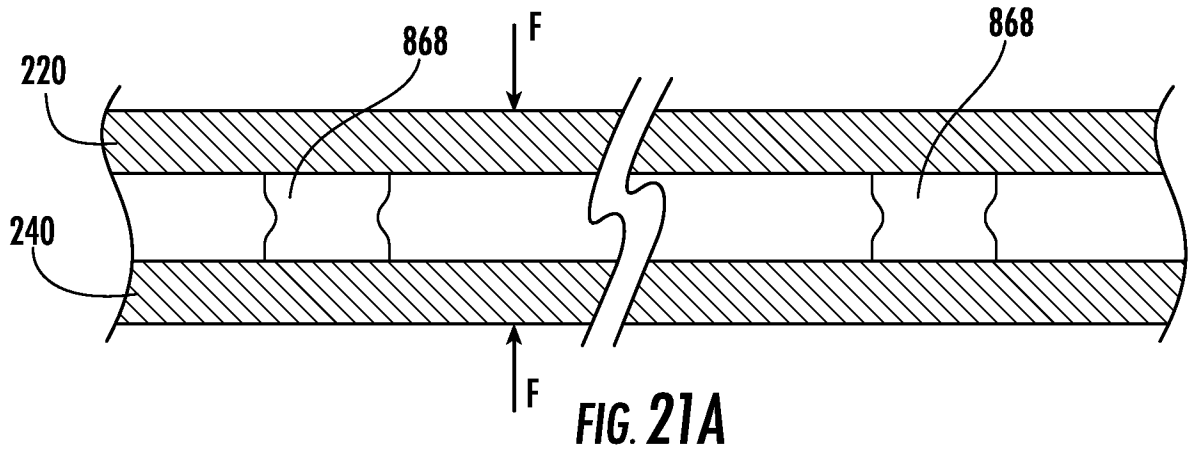

FIG. 20C

36/51



37/51

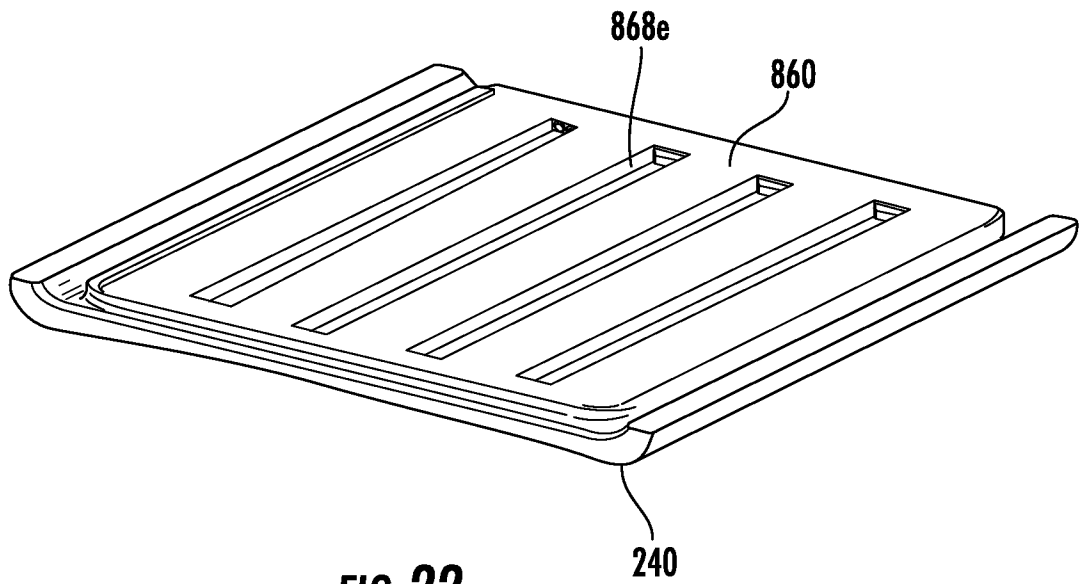

FIG. 22

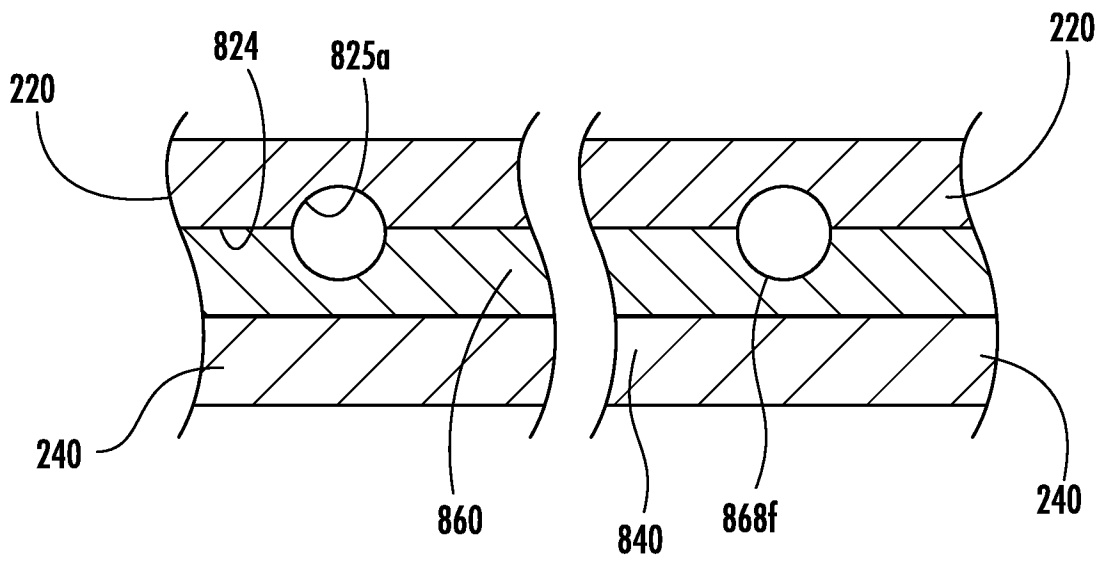

FIG. 23

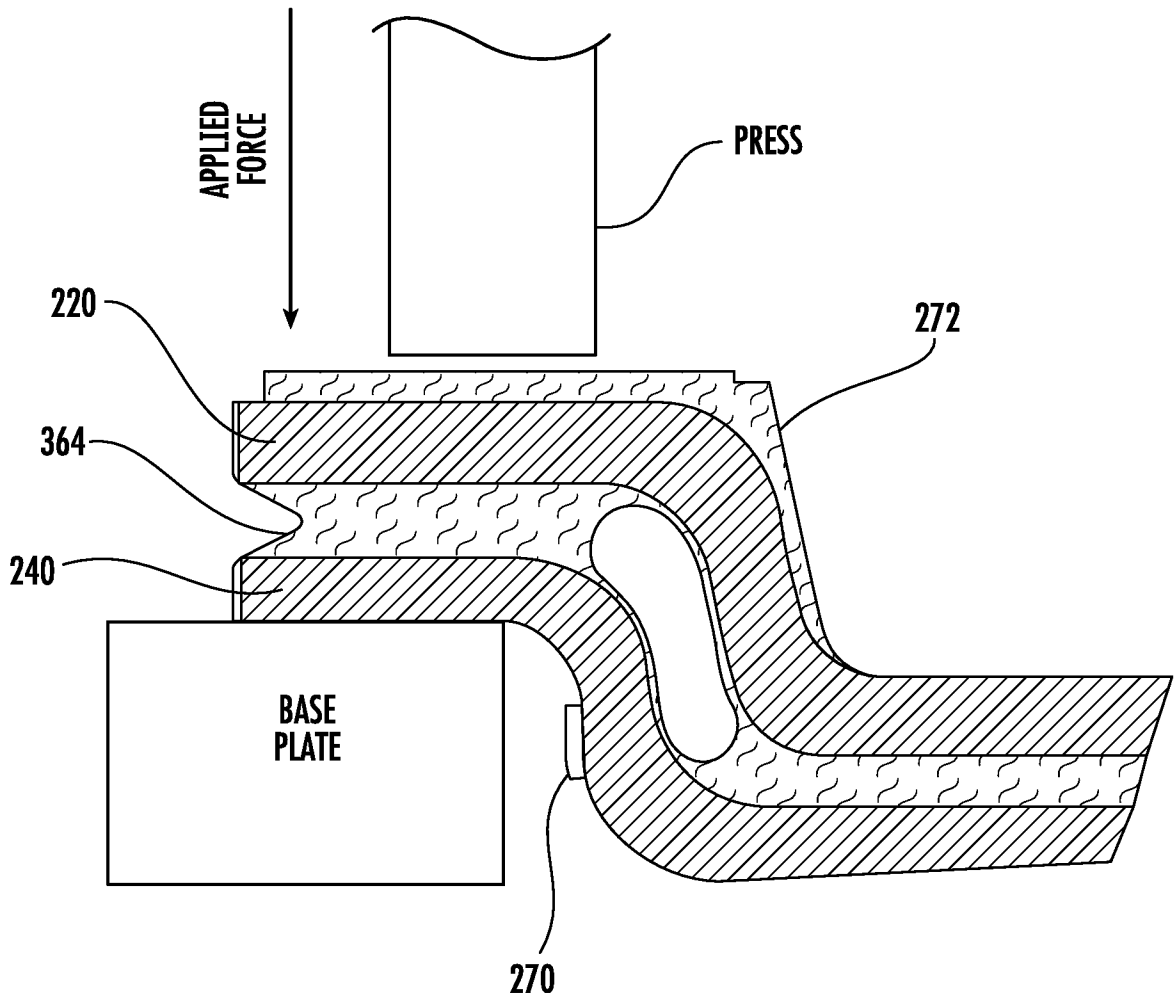

FIG. 24

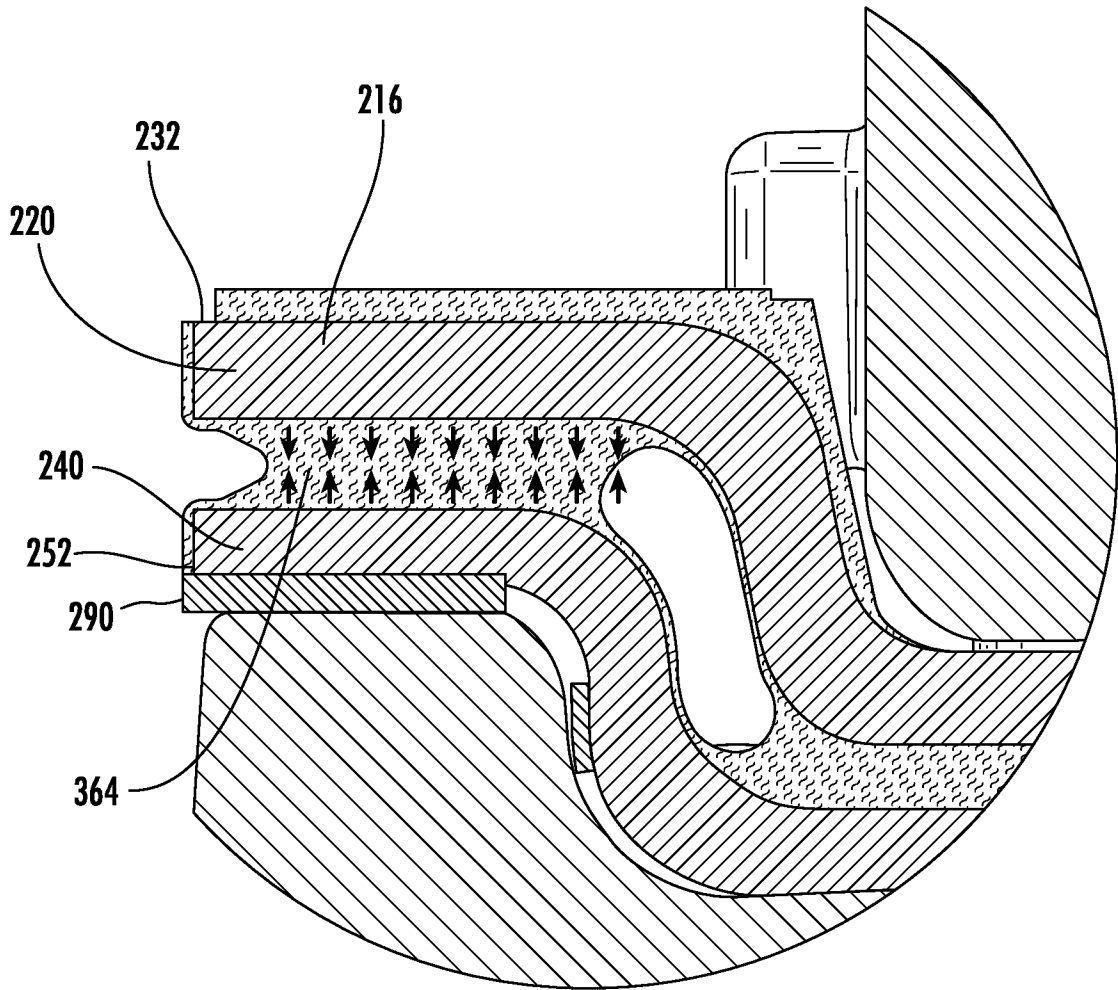

FIG. 25

41/51

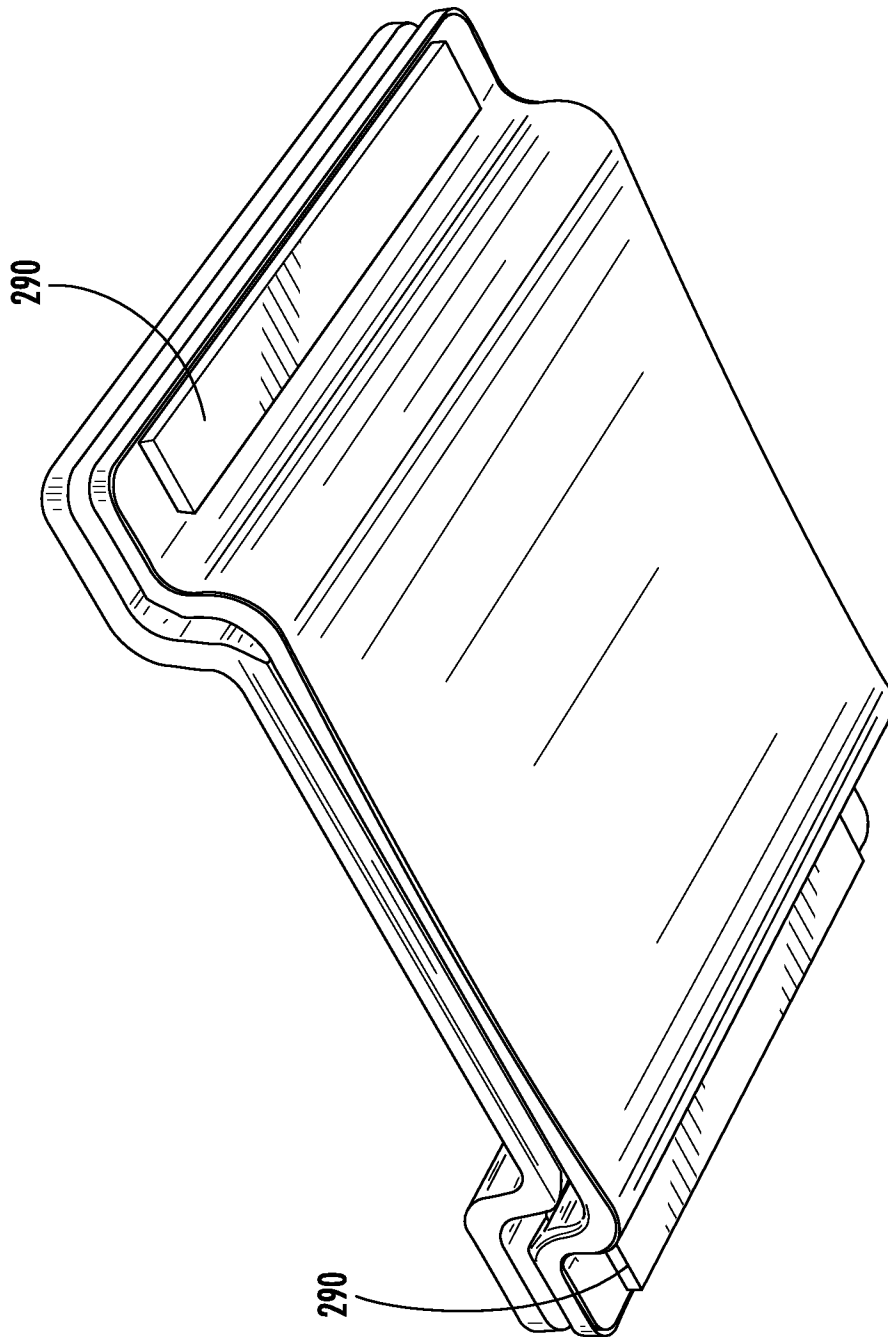

FIG. 25A

42/51

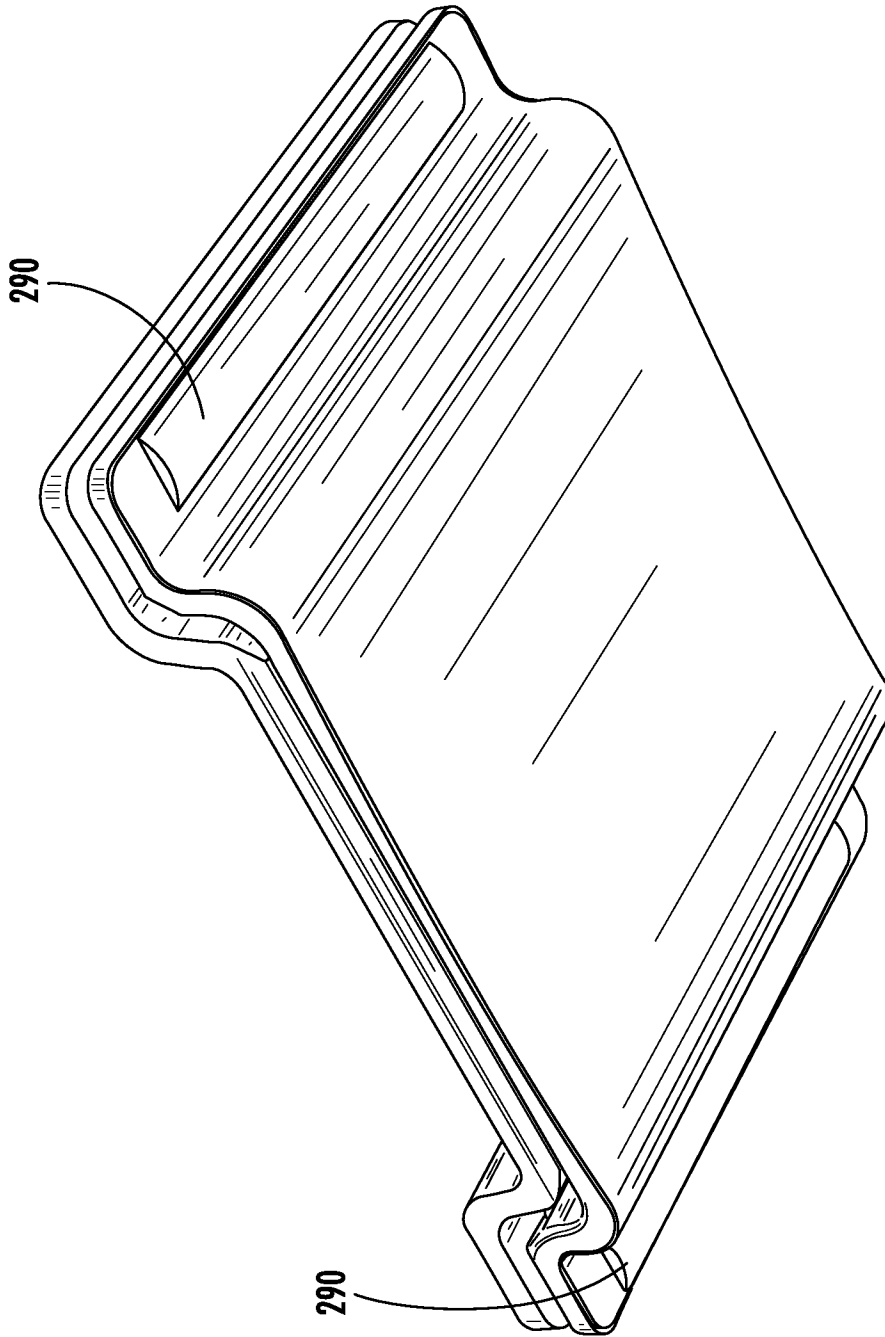

FIG. 25B

43/51

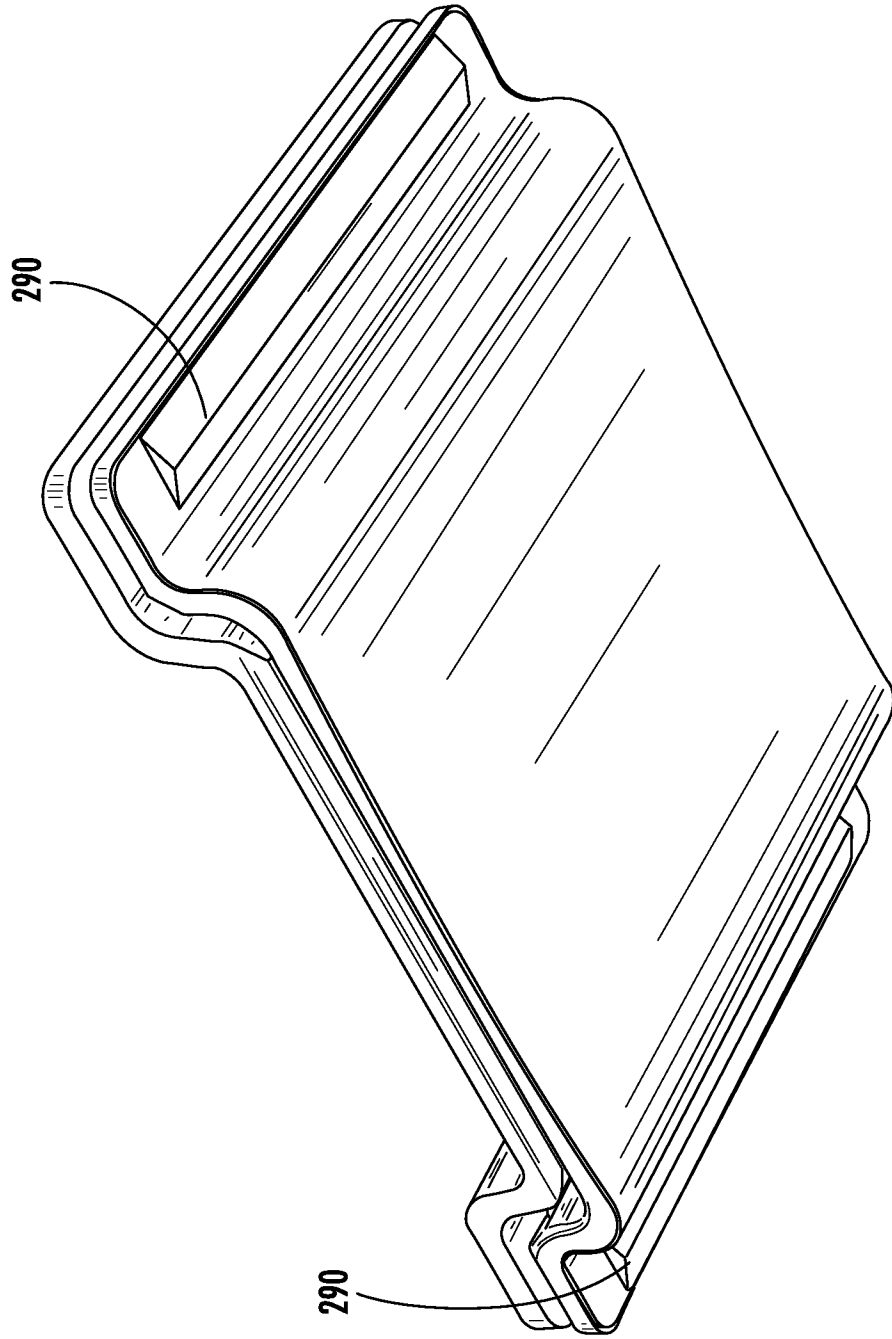

FIG. 25C

44/51

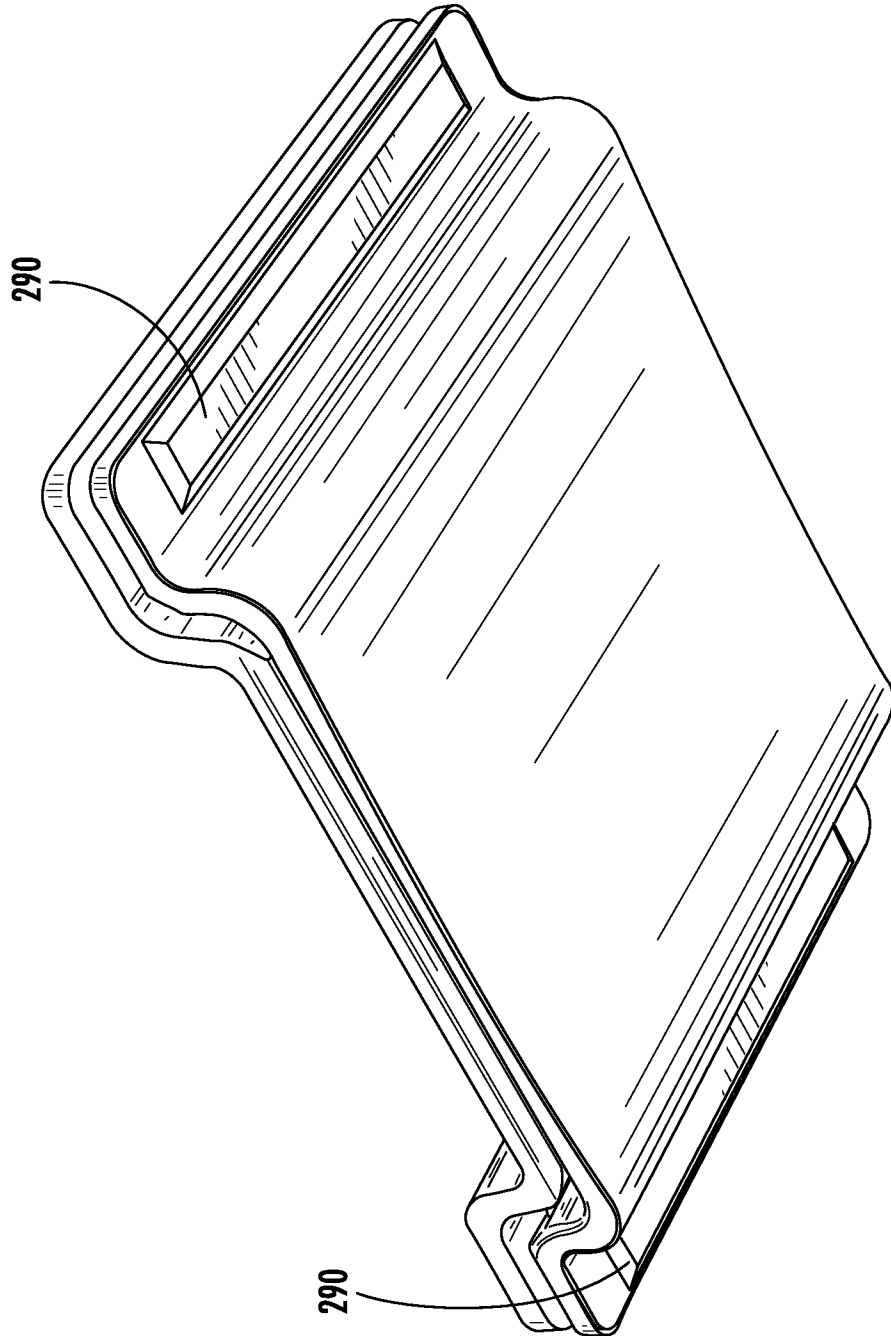

FIG. 25D

45/51

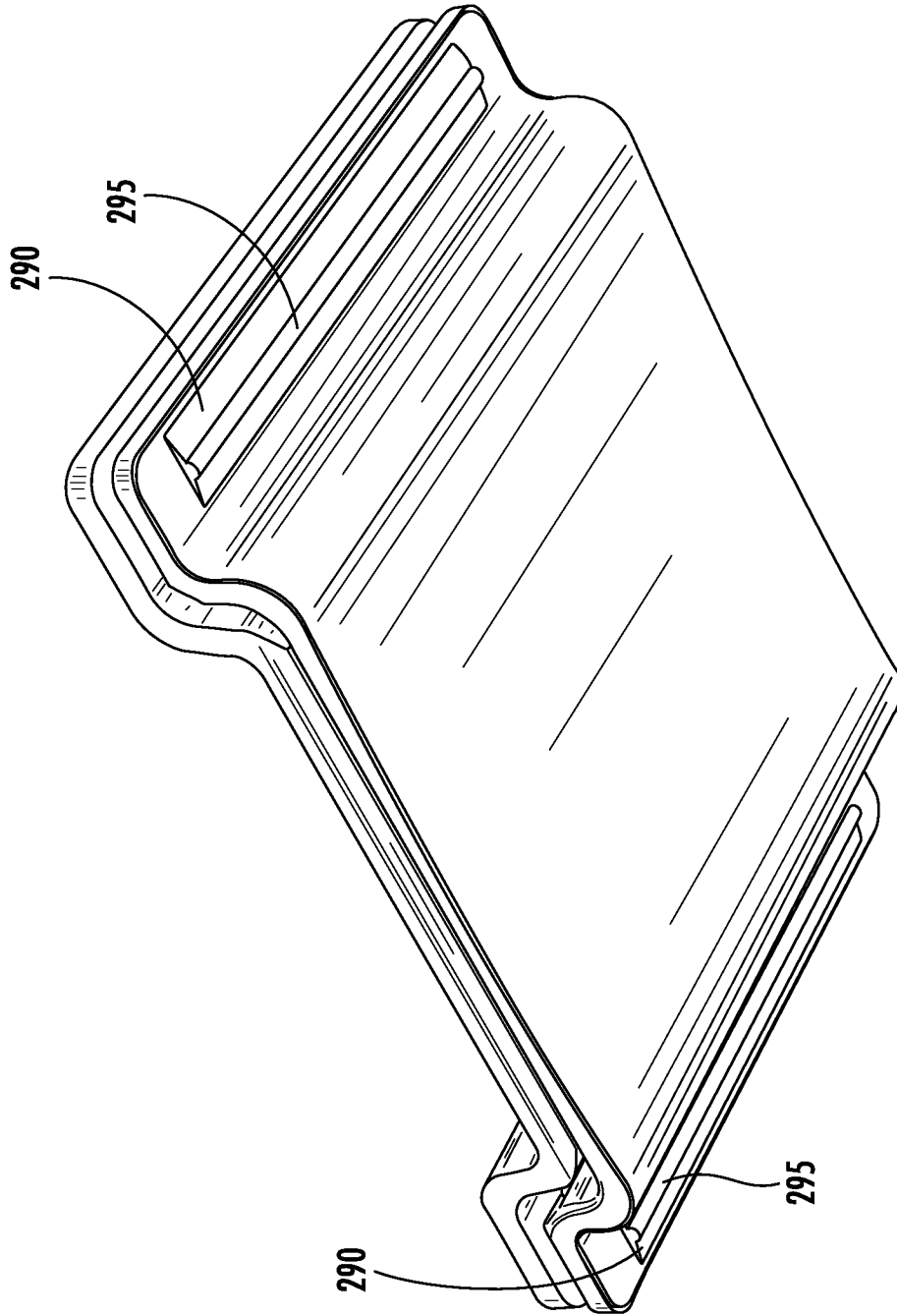

FIG. 25E

46/51

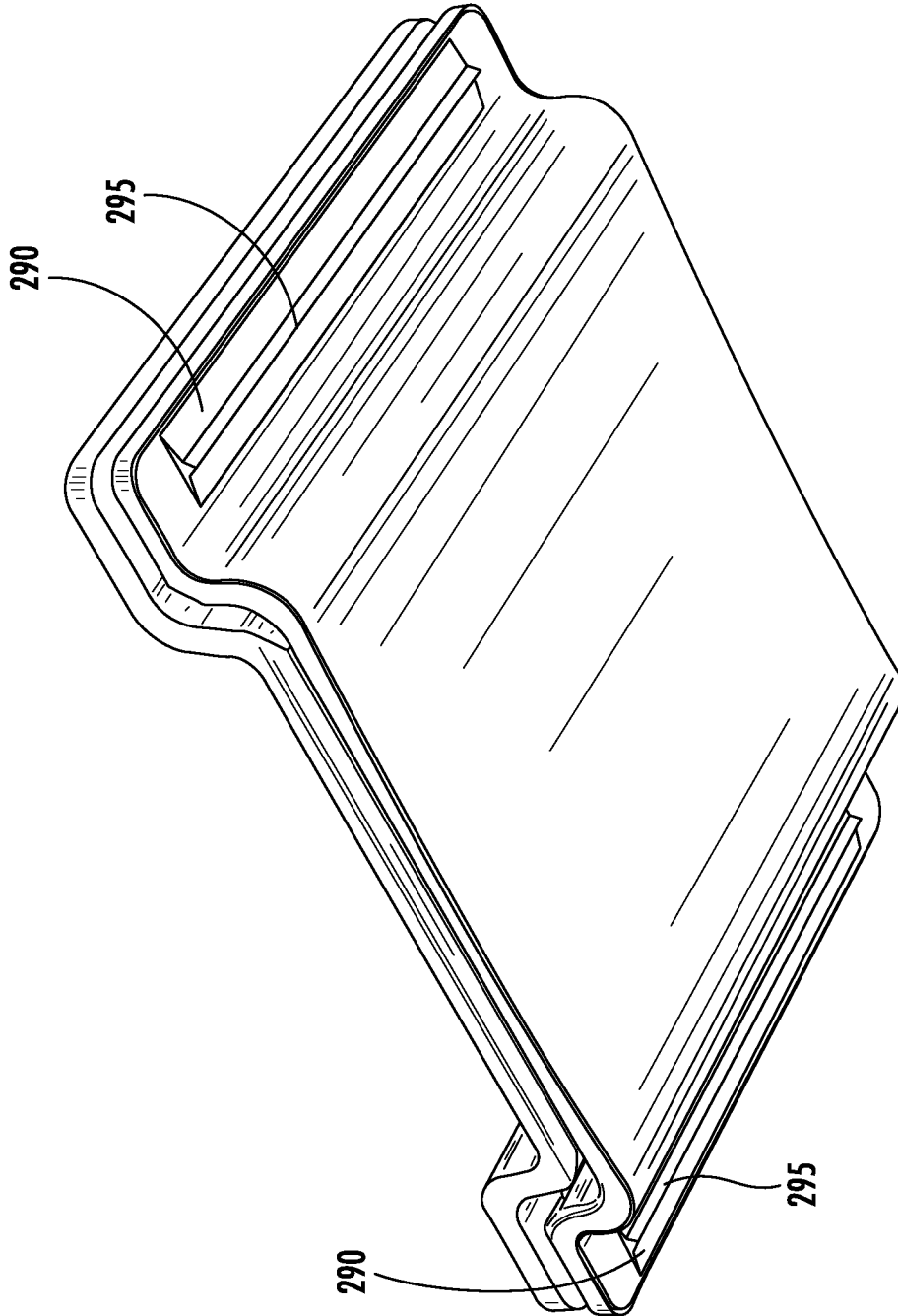

FIG. 25F

47/51

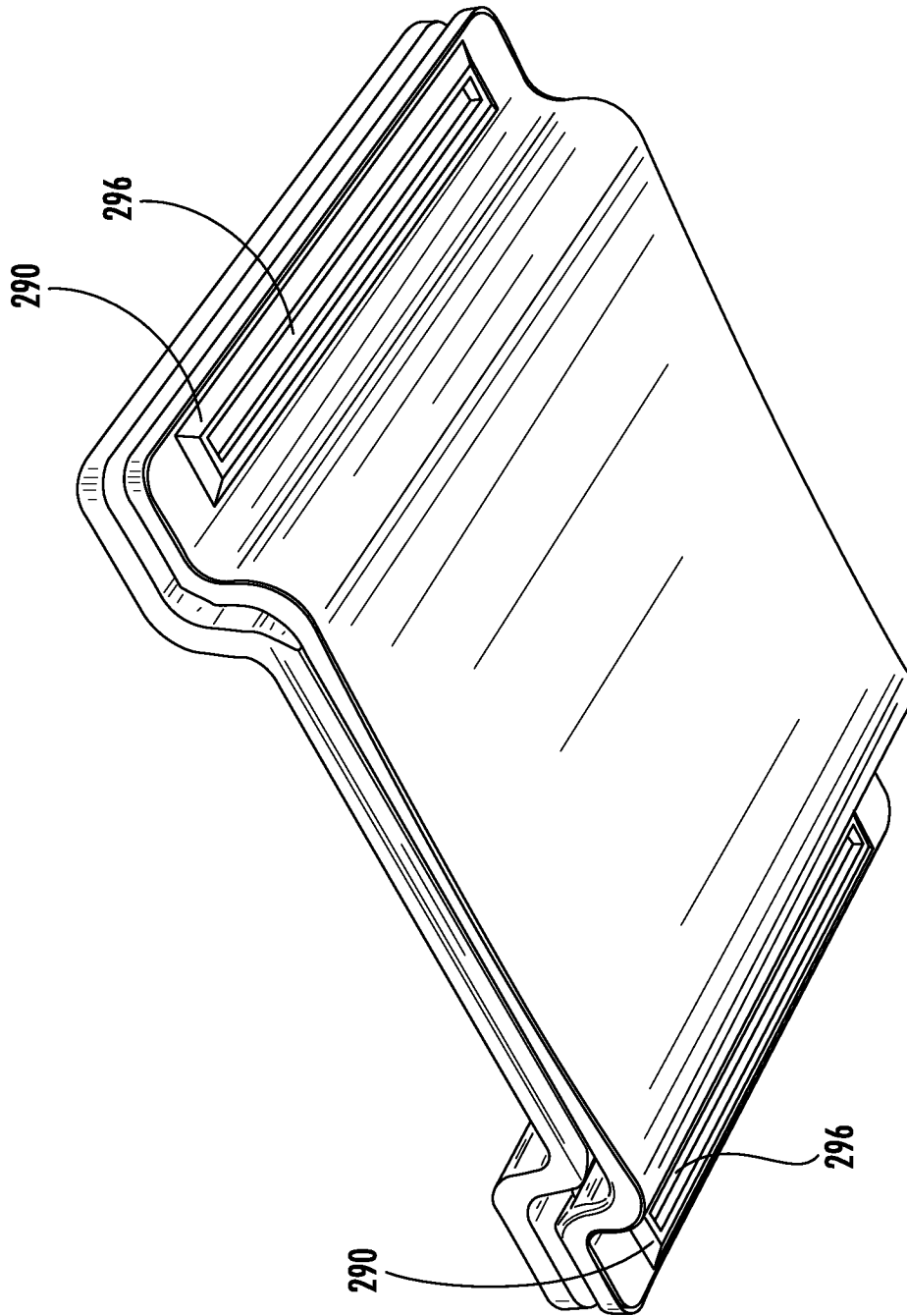

FIG. 25G

48/51

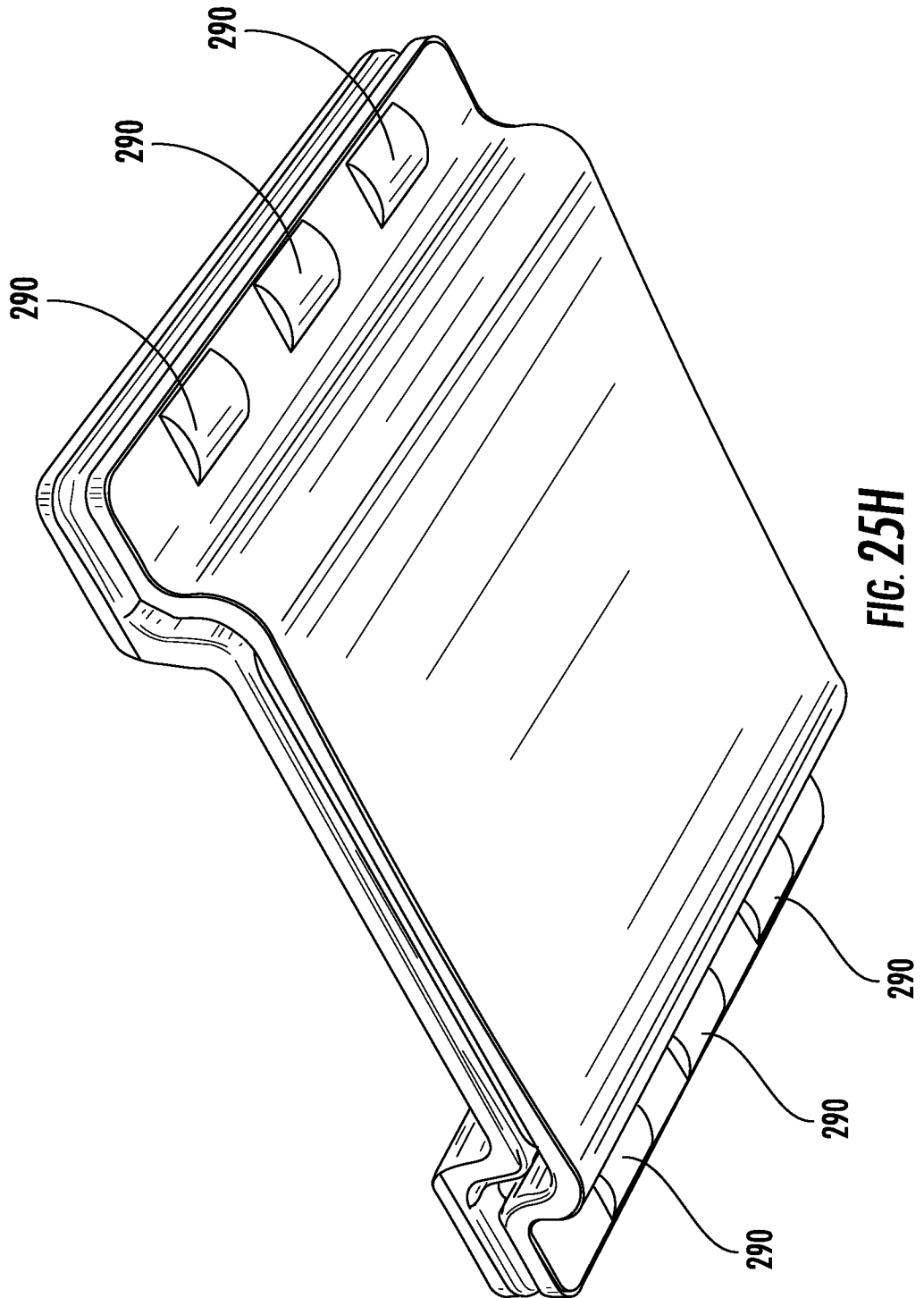

FIG. 25H

49/51

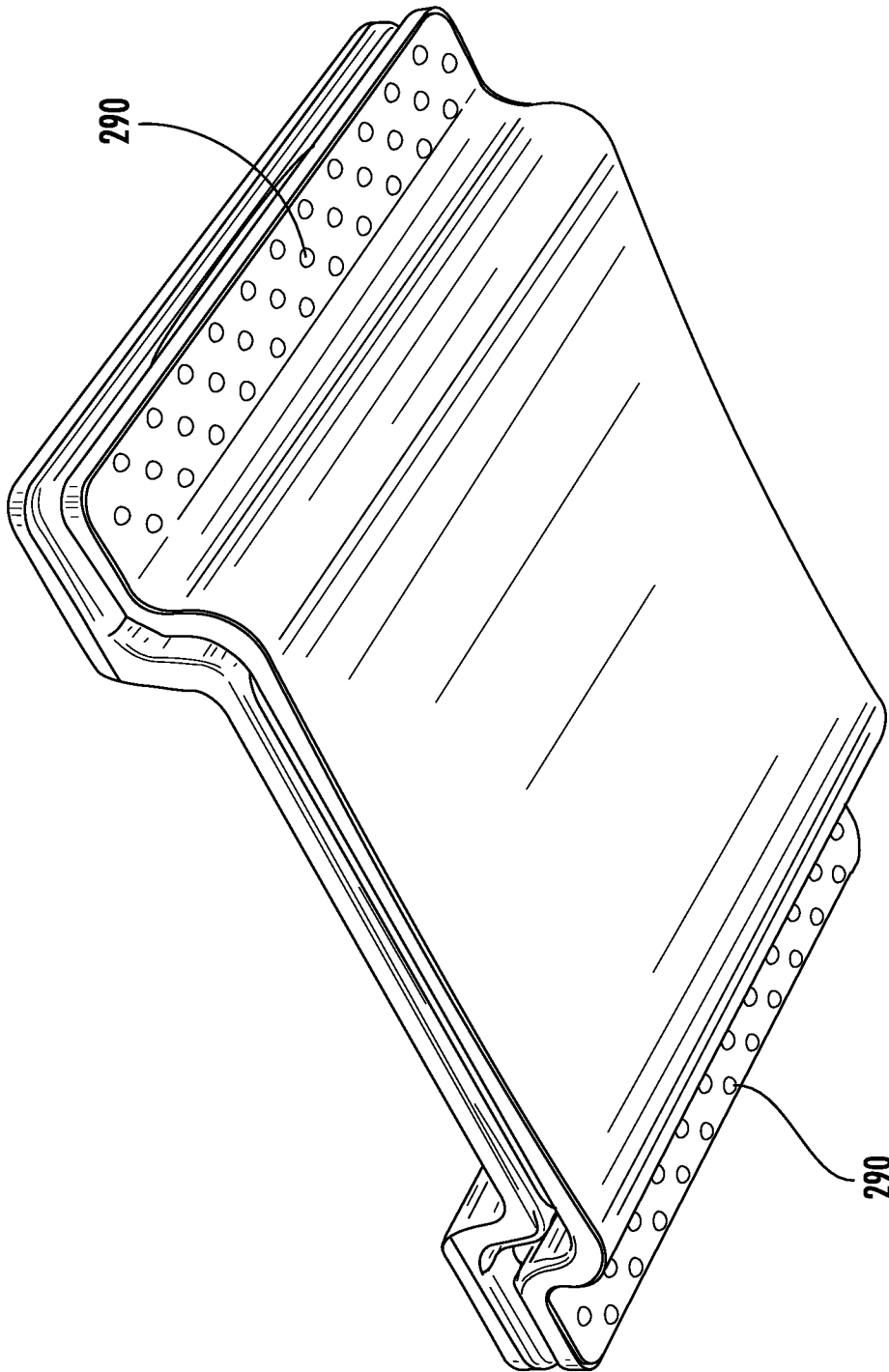

FIG. 251

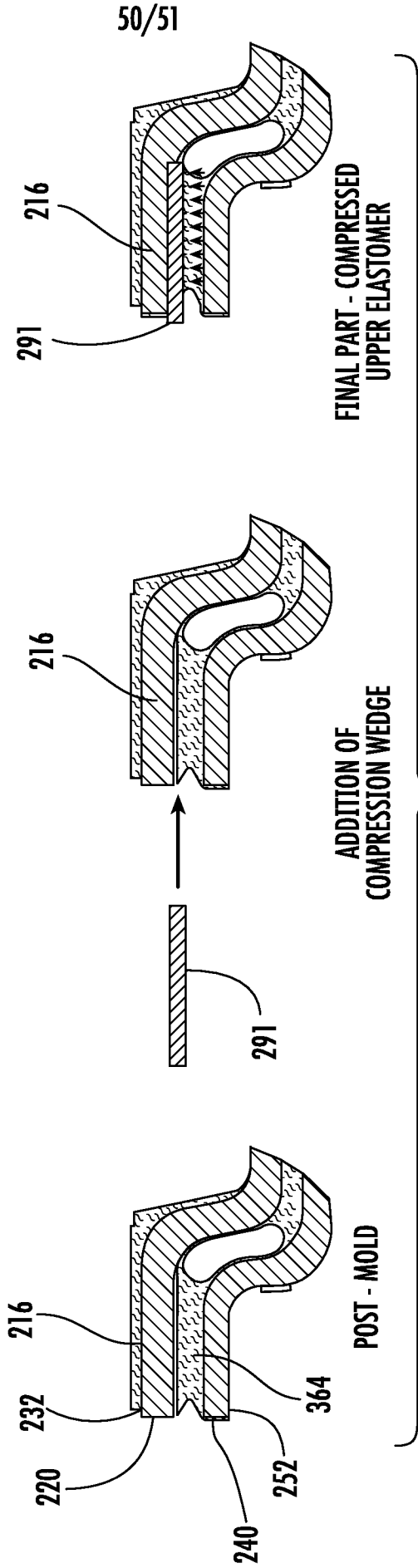

FIG. 26

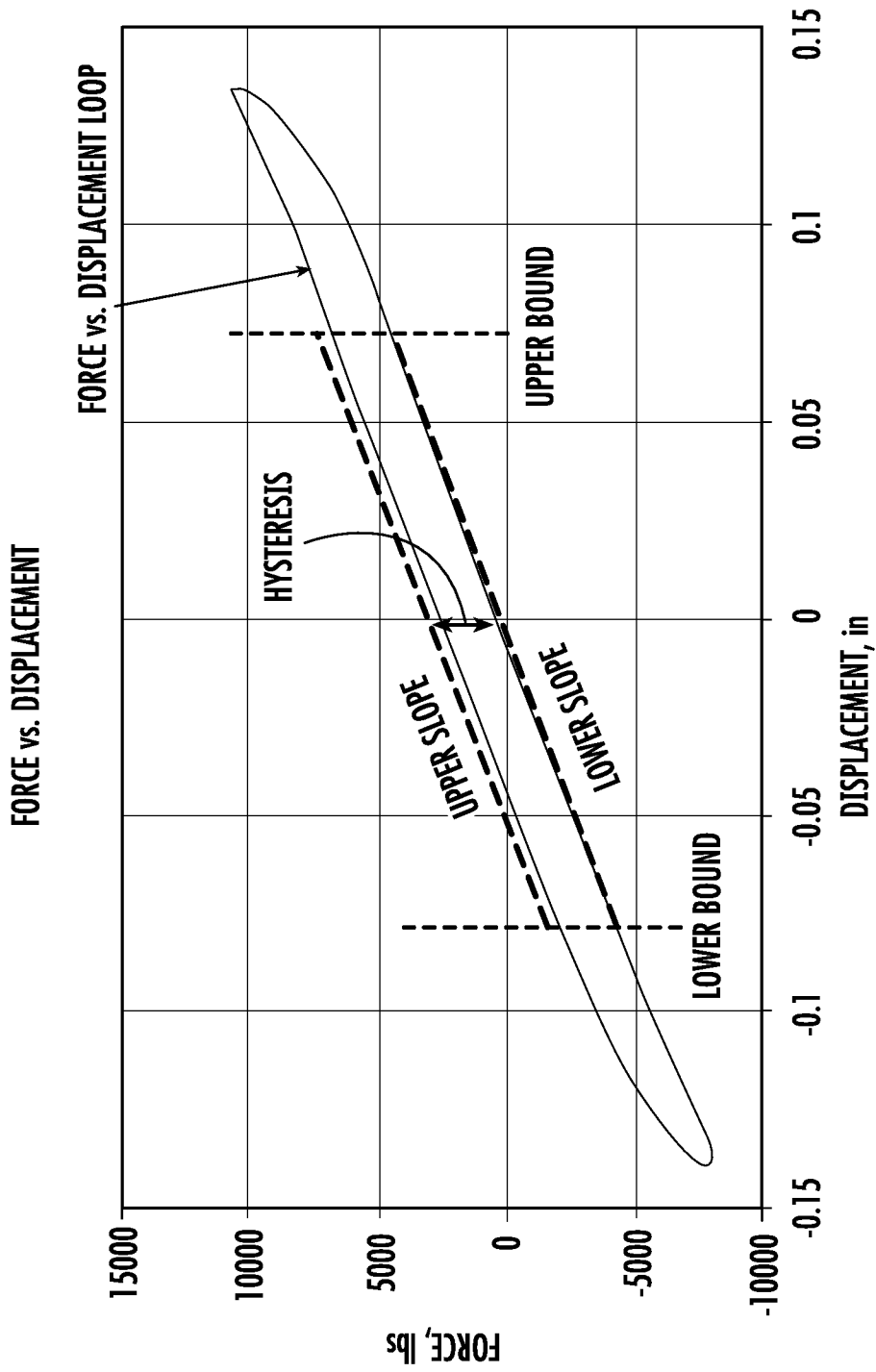

FIG. 27