

May 16, 1933.

M. FALK

1,908,701

BAR HOLDING DEVICE FOR LOCKS

Filed Dec. 22, 1931

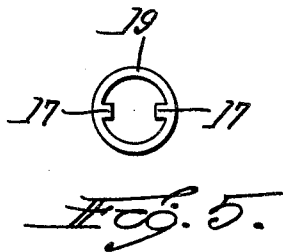
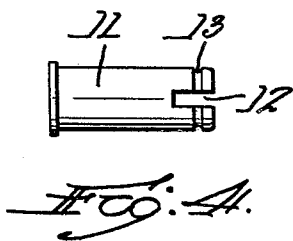
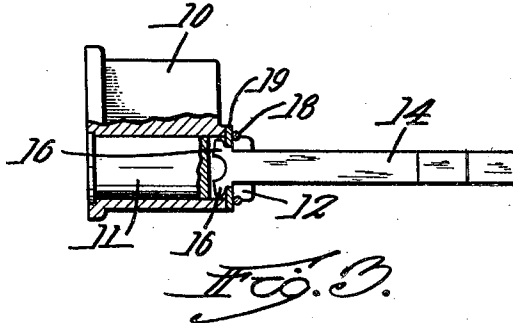
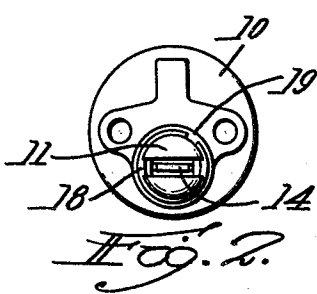
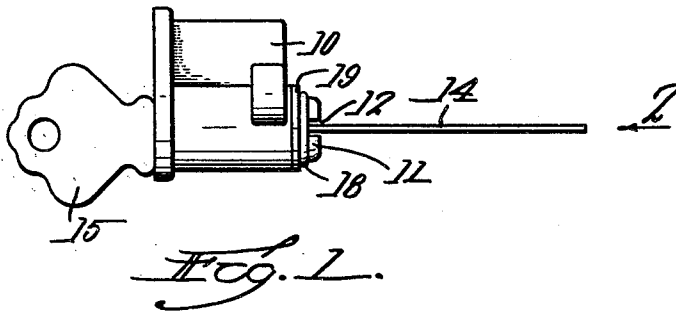

Inventor
Morris Falk
By Attorneys

Sautter, Fay & Harkey

Witness
W. D. McKean

UNITED STATES PATENT OFFICE

MORRIS FALK, OF FITCHBURG, MASSACHUSETTS

BAR HOLDING DEVICE FOR LOCKS

Application filed December 22, 1931. Serial No. 582,561.

This invention relates to an ordinary type of lock and the principal objects thereof are to provide a simple and inexpensive means of assembling; to provide a construction which can be put together very easily and which will remain in assembled condition without danger of the parts becoming detached and particularly to provide a simplified and improved means for connecting the connecting bar with the rotary plug of the lock.

Other objects and advantages of the invention will appear hereinafter.

Reference is to be had to the accompanying drawing, in which

Fig. 1 is a side view of a lock constructed in accordance with this invention;

Fig. 2 is an end view of the same as indicated by the arrow 2 of Fig. 1;

Fig. 3 is a diametrical sectional view;

Fig. 4 is a side elevation of the plug, and

Fig. 5 is an elevation of the retaining washer.

This invention is capable of application to locks of different kinds. It is shown for the purposes of illustration as comprising a casing 10 and plug 11 having pin tumblers, discs or the like, but the locking means are not shown. A key 15 is used as usual in this lock.

The plug is provided with a slot 12 in the end arranged diametrically and is also provided with a circumferential groove 13 near the end. For the purpose of holding the connecting bar 14 in place without going to the comparatively laborious and expensive means usually employed the said bar is provided with spread ends 16 adapted to be inserted in the slot 12.

After these two parts are put in position, as indicated in Fig. 3, a washer 19 is introduced over the end of the plug and up against the end of the casing to close the slot, this washer having a pair of inwardly extending ears 17 for entering the ends of the slot 12 and holding the washer from turning on the plug and also holding the ends 16 in the slot.

The washer is held in position by a spring locking ring 18 which is expanded slightly

from its normal position and introduced into the circular groove and engages the washer 19 and holds it against the casing 10. This ring therefore constitutes the means for holding the parts together. It is applied very readily and being made of spring steel, preferably, it will remain in place in the groove and resist all forces that may be applied to it in the use of the lock.

When the lock is removed from the door and it is desired to take it apart the ring can be pried off in an obvious and simple manner so that the parts are assembled and disassembled with almost equal facility. This constitutes a very simple means for holding the connecting bar with respect to the plug, reduces the cost of manufacture and the cost of assembling and produces a joint which will last as long as any other part of the lock.

Although I have illustrated and described only one form of the invention I am aware of the fact that modifications can be made therein by any person skilled in the art without departing from the scope of the invention as expressed in the claims. Therefore, I do not wish to be limited in this respect, otherwise than as set forth in the claims, but what I claim is:—

1. As an article of manufacture, a lock comprising a locking plug having a slot in its end and an exterior groove circumferentially around it near the end, a connecting bar having a spread end entering said slot and extending across it, means for holding said spread end in the slot, and a spring ring located outside the plug in said groove to hold said means in position.

2. As an article of manufacture, a lock comprising a casing and a plug rotatably mounted therein, the plug having a slot entering its end and a groove around the end, of a connecting bar having a spread end located in said slot, a washer engaging the end of the casing and having a passage there-through for the bar, the groove in the plug being located in a position just beyond said washer, and a spring ring in the groove to hold the washer in position.

3. As an article of manufacture, a lock comprising a locking plug having a slot in

its end and a groove circumferentially around it near the end, a connecting bar having a wide end entering said slot and extending across it, a washer having a pair of inwardly extending ears to retain said spread end of the connecting bar, and a spring ring located in said groove to hold the washer in position.

4. As an article of manufacture, a lock comprising a locking plug having a slot in its end, a connecting bar having an end in said slot, and a washer having a pair of inwardly extending ears for the purpose of turning the washer with the motion of the plug and, at the same time, retaining the spread end of the connecting bar.

5. As an article of manufacture, a lock comprising a locking plug having a slot in its end and a groove circumferentially around it near the end, a connecting bar having a spread end entering said slot and extending across it, a washer having a pair of inwardly extending ears for the purpose of turning the washer with the motion of the plug, and a spring ring located in said groove to hold the washer in position.

In testimony whereof I have hereunto affixed my signature.

MORRIS FALK.

30

35

40

45

50

55

60

65