

Nov. 18, 1924.

1,515,668

M. W. FISCHER

FUSE FOR PROJECTILES

Filed Sept. 26, 1922

2 Sheets-Sheet 1

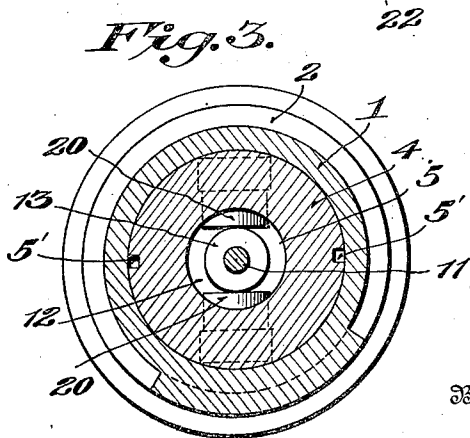
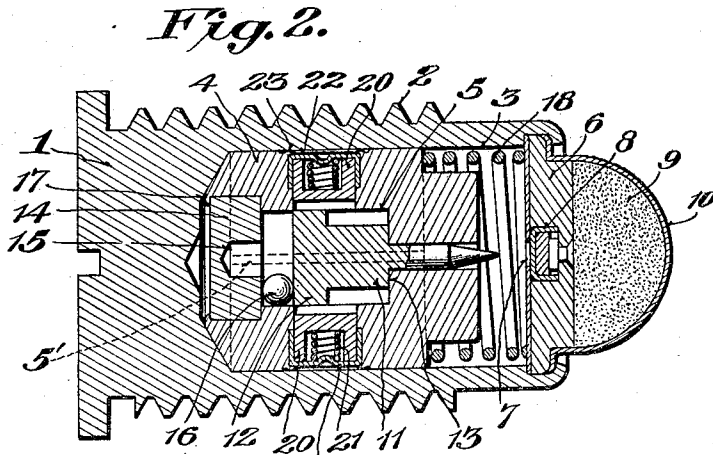
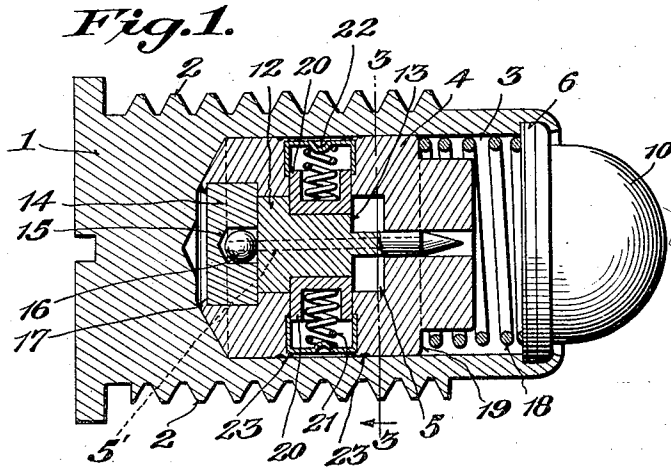

Inventor  
*Max W. Fischer*

By *Maurice Cameron, Lewis H. Keenan*

Attorneys

Nov. 18, 1924.

1,515,668

M. W. FISCHER

FUSE FOR PROJECTILES

Filed Sept. 26, 1922

2 Sheets-Sheet 2

Fig. 4.

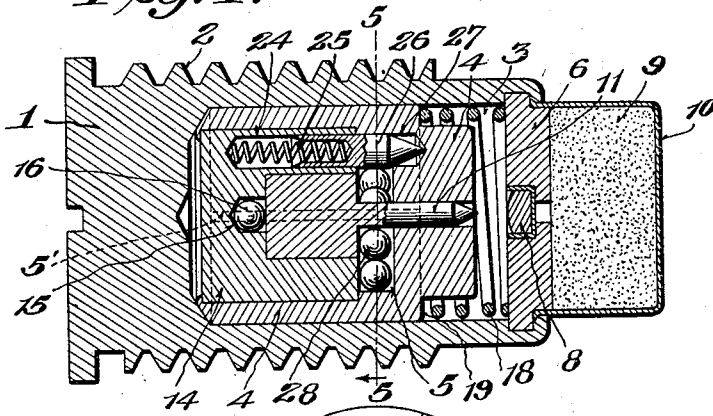

Fig. 5.

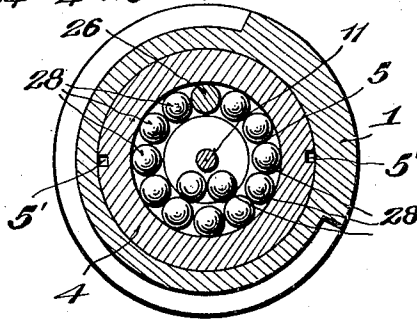
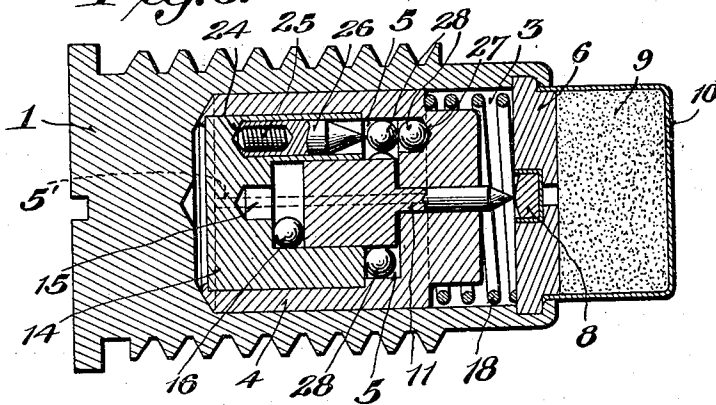

Fig. 6.



Inventor

Max W. Fischer

By *Mauro Cameron* *Attorney*

Attorney

# UNITED STATES PATENT OFFICE.

MAX W. FISCHER, OF WASHINGTON, DISTRICT OF COLUMBIA, ASSIGNOR TO HARRY J. NICHOLS, OF WASHINGTON, DISTRICT OF COLUMBIA.

## FUSE FOR PROJECTILES.

Application filed September 26, 1922. Serial No. 590,697.

*To all whom it may concern:*

Be it known that I, MAX W. FISCHER, citizen of the United States, and resident of Washington, District of Columbia, have invented new and useful Improvements in Fuses for Projectiles, which invention is fully set forth in the following specification.

This invention relates to percussion fuses for firing the bursting charges of explosive projectiles and particularly to the type of fuses employed in explosive projectiles fired from rifled guns.

It has heretofore been proposed to lock the firing pin of a fuse in unarmed position by means of spring-pressed, centrifugal bolts.

The use of these bolts alone, however, does not insure that the firing pin will remain in the unarmed position during the entire period the projectile is being accelerated in the bore of the gun. Investigation has shown that the inertia and friction, due to "set-back", of the bolts is greater than the centrifugal force tending to move the bolts radially to free the firing pin, for only a portion of the time consumed by the projectile in travelling through the bore of the gun.

During the latter part of the travel of the projectile down the bore, the centrifugal force predominates, the bolts move radially, and the firing pin is freed before the projectile has left the gun. In case the bore of the gun is constricted or damaged due to coppering, etc., the projectile, in passing this defective portion of the bore, has its acceleration momentarily checked, and the centrifugal bolts, if they have not already done so, will move outwardly, thus rendering the firing means operative while the projectile is yet in the gun. If the fuse is very sensitive, this momentary checking of the acceleration of the projectile is often sufficient to fire the fuse, and in the past there have been many instances where firing devices depending for safety on centrifugal bolts have fired prematurely in the bore of guns.

One of the objects of the present invention is to provide a fuse which is "bore-safe", thereby insuring against premature firing and consequent danger to personnel.

It has also been proposed, heretofore, to provide a fuse in which the firing pin is forced into armed position by resilient or centrifugally actuated means and then positively locked in the armed position.

Another object of this invention is to provide a fuse such that the firing pin will be moved to firing position solely by means of its own inertia, and to provide means whereby the firing pin will be automatically and positively locked in armed position in order that the fuse will be certain in its operation regardless of the angle at which the nose of the projectile strikes its objective.

Other objects of this invention are to provide a fuse simple in construction and economical in manufacture, and which will be safe while being handled or transported. These and other objects will appear as the description proceeds.

The invention is capable of receiving a variety of mechanical expressions, two of which for the purpose of illustration, have been shown in the accompanying drawings, but it is to be expressly understood that the drawings are for purposes of illustration only and are not to be construed as definitive of the limits of the invention, reference being had to the appended claims for that purpose.

Referring to the drawings, wherein the same reference characters designate corresponding parts in the several figures,

Fig. 1 is a central vertical section through a fuse embodying the present invention, showing the parts in unarmed position;

Fig. 2 is a view similar to Fig. 1 showing the firing pin locked in armed position;

Fig. 3 is a sectional view taken on the line 3-3 of Fig. 1;

Fig. 4 is a central vertical section through another fuse embodying the present invention, showing the parts in unarmed position;

Fig. 5 is a sectional view taken on the line 5-5 of Fig. 4; and

Fig. 6 is a view similar to Fig. 4 showing the firing pin locked in armed position.

To illustrate the embodiment of this invention I will proceed to describe its application to a non-delay action type of fuse, but it is to be expressly understood that the invention is not restricted thereto as by suitably selecting the proportion of parts the invention is applicable to other types of fuses for projectiles that are stabilized, by rapid rotation, during their flight.

In the form shown in Figs. 1 to 3, inclusive, 1 is the usual fuse body, of any suitable size and material, which forms the mount-

ing for the percussion mechanism and which is provided with the external threads 2 by means of which the fuse is secured in position in the projectile. Slidably mounted within the longitudinal cavity 3 of body 1 is the plunger or hammer 4 provided with a cylindrical recess or cavity 5 and the diametrically disposed grooves 5'. Suitably secured to the forward end of body 1 is the fixed plate or primer holder 6 provided with a vent 7 and carrying the primer 8 of any suitable type. A charge of powder or the like 9, encased in a magazine 10 suitably secured to body 1, may be employed to augment the effect of primer 8 in a well-known manner.

Slidably mounted in recess 5 is a firing pin 11 of any suitable shape but preferably light in weight for a purpose to be described hereinafter. Pin 11 is provided with a flanged base 12 and preferably with a shoulder 13. The rear end of recess 5 is closed by a plug 14 having a centrally located cup 15, in the front face thereof, adapted to receive a locking ball 16 of any suitable size. Plug 14 is preferably secured in the rear end of plunger 4 by upsetting the after bevelled edge of the plunger as indicated at 17. Plunger or hammer 4 is prevented from moving forward under the influence of the retardation produced by the resistance of the air to the flight of the projectile carrying the fuse, which influence is commonly referred to in the art as "creep," by a creep spring 18, which abuts at its forward end against plate 6 and at its after end against a shoulder 19 formed on plunger 4.

Mounted within radial passages, formed in the walls of plunger 4, are the centrifugal locking bolts 20, 20 which are normally held in engagement with flanged base 12 of firing pin 11 by means of springs 21, 21, the outer ends of said springs bearing against the retainers 22, 22. These retainers, which may be stamped or pressed, are preferably cup-shaped and are held in place in plunger 4 by upsetting the metal thereof as at 23, 23.

The operation of the device is as follows: When a projectile provided with my fuse is fired, the rifling of the gun imparts sufficient rotation to the projectile to cause locking bolts 20, 20 to move outwardly in the radial passages, leaving cavity 5 unobstructed and firing pin 11 free to move forward to armed position.

This forward movement of the firing pin is produced solely by "creep" or the force of inertia produced by the influence of the air resistance which begins to retard the forward movement of the projectile soon after it emerges from the muzzle of the gun, the plunger or hammer 4 being held rearwardly by means of creep spring 18. The arming of the firing pin is therefore not completed

normally until after the projectile has emerged from the gun.

As the firing pin moves or "creeps" forward, it is followed by the locking ball 16 which, upon leaving the cup or recess 15, is thrown radially into the space which separates pin 11 from plug 14 and held there by centrifugal force, thereby positively locking the firing pin in armed position.

On impact of the projectile with the target, the weight of plunger 4 and firing pin 11 is effective in firing the primer.

As previously stated, a light firing pin is used such that in case there is a constriction in the bore of the gun, the firing pin and plunger move forward with the same acceleration and velocity, except for the slight restraining effect of creep spring 18 which is almost negligible due to the weight of plunger 4, so that plunger and firing pin arrive at their forward position without sufficient relative movement having taken place to permit the firing pin to be locked in the armed position by means of ball 16. The weight of plunger or hammer 4 is thus not available for firing primer 8. The mass and relative forward movement of pin 11 are so small that the impact of the same is insufficient to fire said primer.

In Figs. 3 to 6, inclusive, there is illustrated another embodiment of the inventive idea in which plug 14, in addition to cup 15, is provided with a cup or cavity 24 opening into cavity 5 of plunger or hammer 4. A spring 25 positioned in cavity 24 normally holds a locking plunger 26 in the forward position, indicated in Fig. 4, which plunger extends into a depression or cup 27, formed in plunger or hammer 4, opening into recess or cavity 5.

Positioned within recess 5 are a plurality of balls 28 of the same diameter as that of plunger 26 and of such a number that there is one more than is necessary to form a complete ring whose outer diameter is equal to that of recess 5.

The operation of this embodiment of the invention is as follows: When a projectile carrying the fuse is fired the inertia of plunger 26 moves it rearwardly in cavity 24 with such force that plunger 26 is jammed and held in the bottom of cavity 24. The centrifugal force of the projectile throws balls 28 radially in such a manner that they form a complete ring around the circumference of cavity 5, one ball occupying the position formerly occupied by plunger 26 while the extra ball remains in a position immediately in front of firing pin 11 so that the latter is locked in unarmed position. Acting under the influence of "creep," the ball opposite cup 27 moves forward into said cup and the remaining ball is thrown by centrifugal force into the space left vacant by the ball now seated in cup 27. At this in-

stant, firing pin 11 is freed and its inertia or "creep" moves it forward to armed position, where it is locked by ball 16 which moves forward into the space between said pin and plug 14 as shown in Fig. 6.

It will be perceived that the firing pin is positively locked in unarmed position during the time the projectile is moving through the bore of the gun—in short, the fuse is made positively "bore safe." Upon impact of the projectile with the objective, the weight of plunger 4 and firing pin 11 is effective in firing primer 8.

From the foregoing it will be perceived that the several movable elements act without mutual interference and in the correct sequence to accomplish one of the prime objects of this invention, viz., the arming and locking of the firing pin after the projectile has left the bore of the gun and then only.

Since fuses must be made in enormous quantities, a minimum number of inexpensive parts which may be readily assembled are imperative, and my invention meets the requirements of inexpensive manufacture to an unusual degree.

While the two embodiments of the invention illustrated on the drawings have been described with considerable particularity, it is to be expressly understood that the invention is not to be restricted to the forms there shown for it is capable of receiving a variety of mechanical expressions, some of which will readily suggest themselves to those skilled in the art, while certain features thereof are capable of use without other features thereof. Furthermore, it will be apparent that my fuse may be used either as a base fuse or as a nose fuse. Reference is therefore to be had to the claims hereto appended for a definition of the invention.

What is claimed is:—

1. In a fuse for projectiles, the combination of a casing, a hammer slidably mounted in said casing, a firing pin slidably mounted in said hammer adapted to creep to armed position, means for normally locking said pin in unarmed position, and means adapted to creep forward independently of the pin for locking the latter in armed position, said last named means being rendered operable by the creep of said pin.

2. A fuse for projectiles comprising a casing, a plunger within said casing, a firing pin in said plunger adapted to creep to armed position, means for normally locking said pin in unarmed position, and a ball for locking said pin in armed position said ball being positioned rearwardly of said pin.

3. A fuse for projectiles comprising a casing, a plunger within said casing, a firing pin in said plunger adapted to creep to armed position, means for normally locking said pin in unarmed position, and means

adapted to creep forwardly independently of said pin to positively lock the latter in armed position.

4. In a fuse, the combination of a casing, a hammer therein provided with a recess, a firing pin in said recess, means normally locking said pin in unarmed position and movable by centrifugal force to free said pin, said pin being adapted to creep to armed position when freed by said last-named means, and means movable by inertia independently of the pin, to thereafter lock said pin in armed position.

5. A fuse for projectiles comprising a casing, a plunger within said casing, a firing pin in said plunger, means normally locking said pin in unarmed position, said pin being adapted to creep to armed position when freed by said means, and means movable forwardly by the force of inertia, independently of said pin, to positively lock the latter in armed position.

6. In a fuse, the combination of a casing, a hammer therein provided with a recess, a firing pin in said recess, a plurality of elements normally locking said pin in unarmed position and movable by centrifugal force to free said pin, a plunger slidably mounted in said hammer and normally preventing said elements from freeing said pin until the fuse is fired from a gun, and means for locking said pin in armed position.

7. In a fuse, the combination of a casing, a hammer therein provided with a recess, a firing pin in said recess, a plurality of balls normally positioned in front of said pin for locking the latter in unarmed position, means positioned in said hammer for normally maintaining said balls in locking position, and means for locking said pin in armed position.

8. In a fuse, the combination of a casing, a hammer therein provided with a recess and a cup, a firing pin in said recess, a plunger normally projecting into said cup, a plurality of balls for locking said pin in unarmed position, one of said balls being adapted to move into said cup after a projectile carrying said fuse has been fired from a gun, and means for locking said pin in armed position.

9. In a fuse, the combination of a casing, a hammer therein provided with a recess, a firing pin in said recess, means normally locking said pin in unarmed position and movable to free said pin, said means comprising a spring-pressed plunger and a plurality of balls, said pin being movable to armed position by inertia when freed by said means, and means to lock said pin in armed position.

10. In a fuse, the combination of a casing, a hammer therein provided with a cup and a recess, a firing pin in said recess, means normally locking said pin in unarmed posi-

tion. said means comprising a spring-pressed plunger and a plurality of balls, one of said balls being adapted to be moved into said cup by centrifugal force and inertia, and means for locking said pin in armed position.

11. In a fuse, the combination of a casing, a hammer therein provided with a recess, a resilient member interposed between said

casing and hammer, a firing pin in said recess adapted to creep to armed position, means normally locking said pin in unarmed position and a ball for locking said pin in armed position, said ball being rendered operable by the creep of said pin.

In testimony whereof I have signed this specification.

MAX W. FISCHER.