

1,000,589.

E. DE JOURNO.  
DYEING APPARATUS.  
APPLICATION FILED APR. 22, 1909.

Patented Aug. 15, 1911.  
4 SHEETS—SHEET 1.

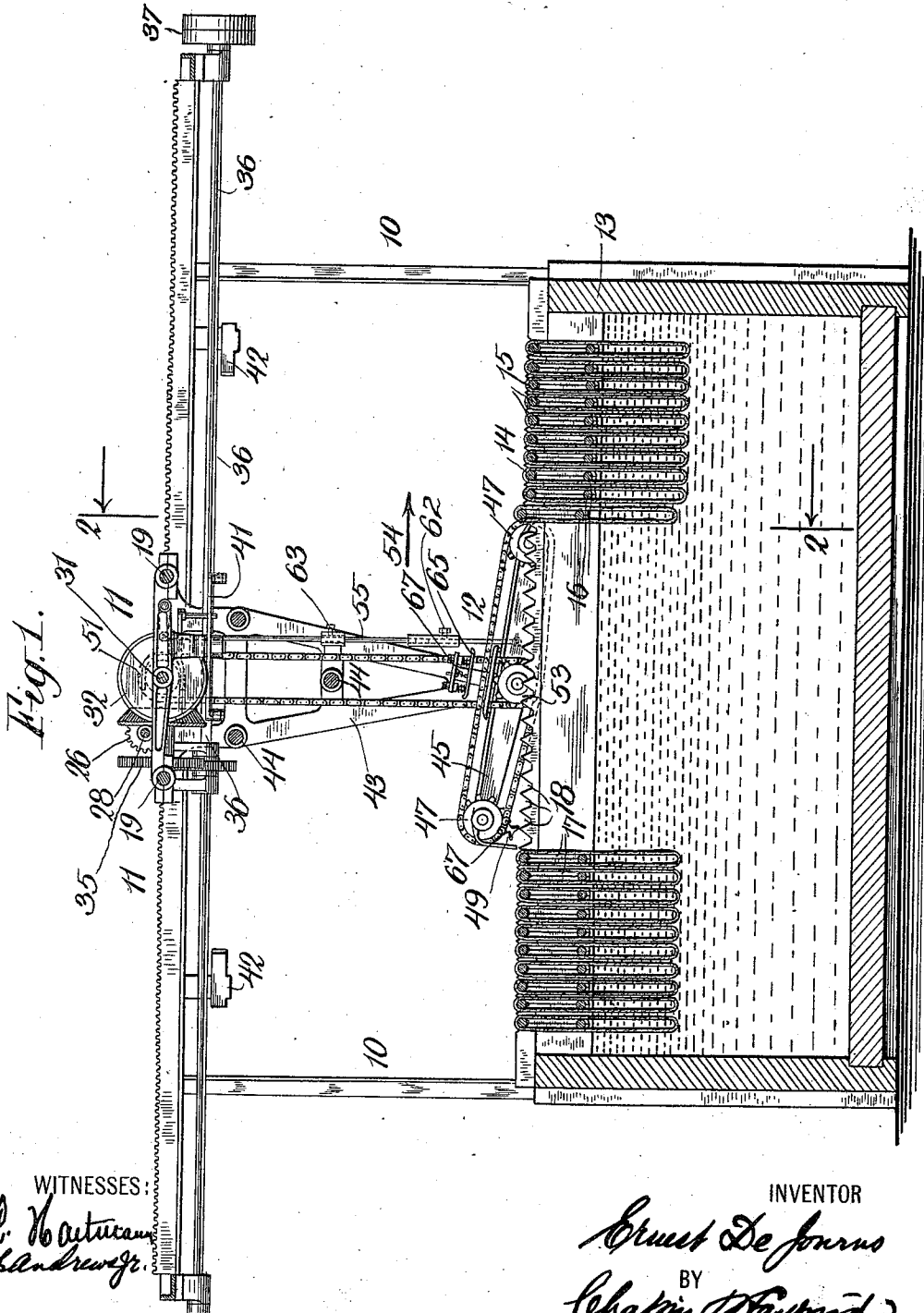

WITNESSES:  
*J. P. Hartman*  
*J. S. Anderson*

INVENTOR  
*Eust De Jours*  
BY  
*Chapin Raymond*  
his ATTORNEYS

E. DE JOURNO.  
DYEING APPARATUS.

APPLICATION FILED APR. 22, 1909.

Patented Aug. 15, 1911.

4 SHEETS—SHEET 2.

1,000,589.

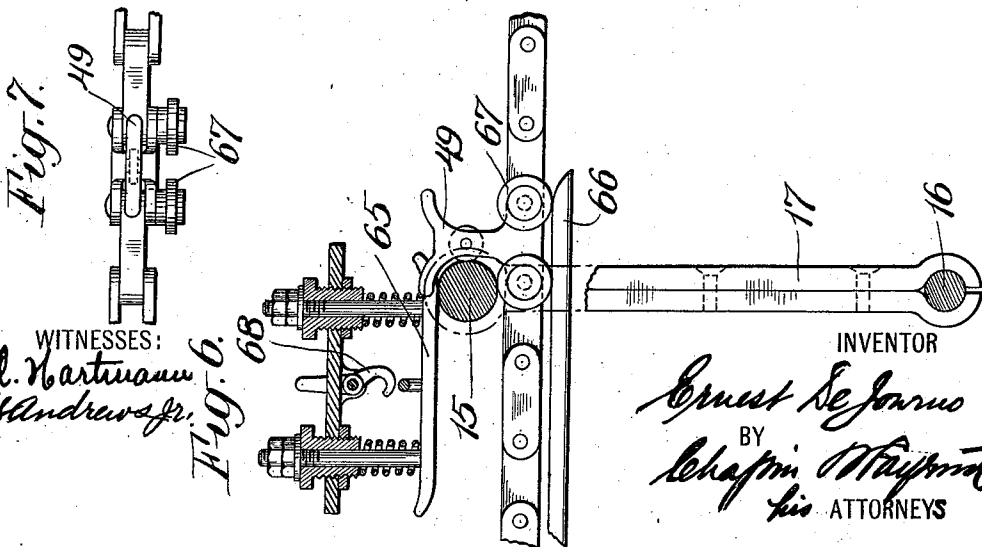
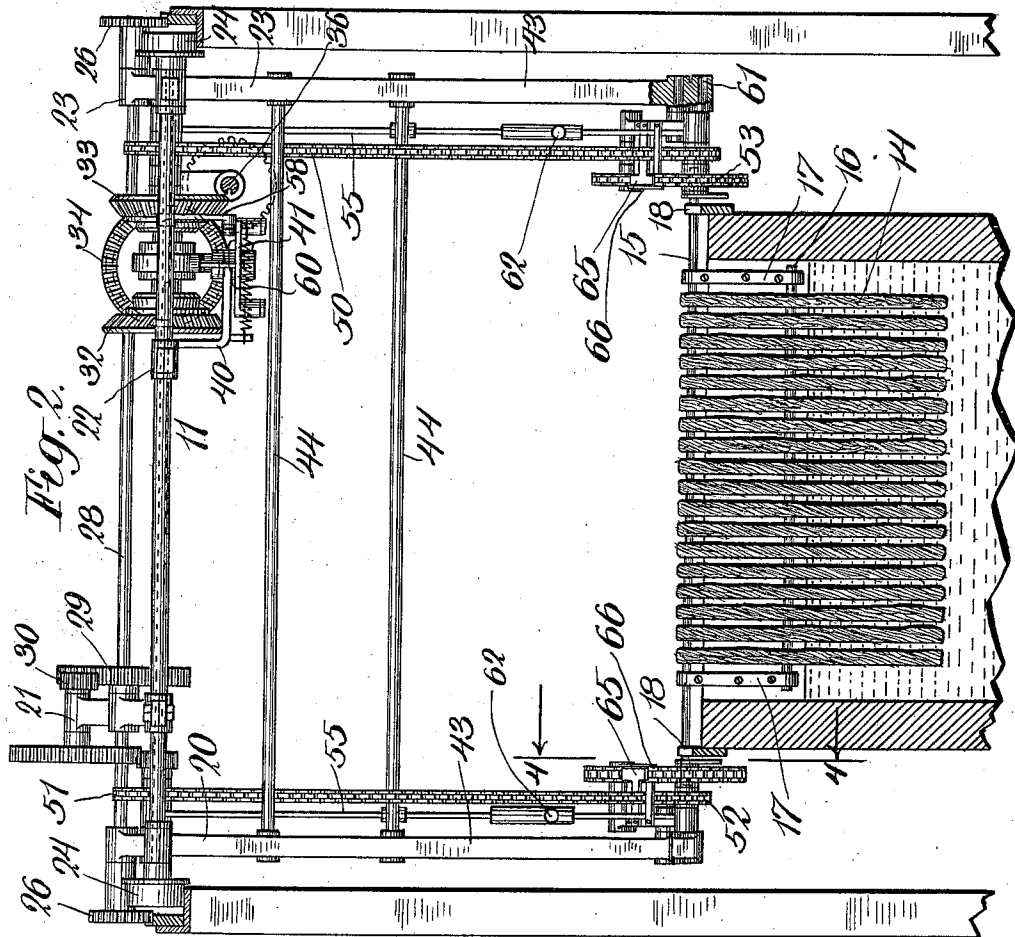

WITNESSES:  
*J. L. Hartmann*  
*H. Andrews, Jr.*

Fig. 6.

INVENTOR  
*Ernest De Jouno*  
BY  
*Chapin Raymond*  
his ATTORNEYS

E. DE JOURNO.  
DYEING APPARATUS.

APPLICATION FILED APR. 22, 1909.

1,000,589.

Patented Aug. 15, 1911.

4 SHEETS—SHEET 3.

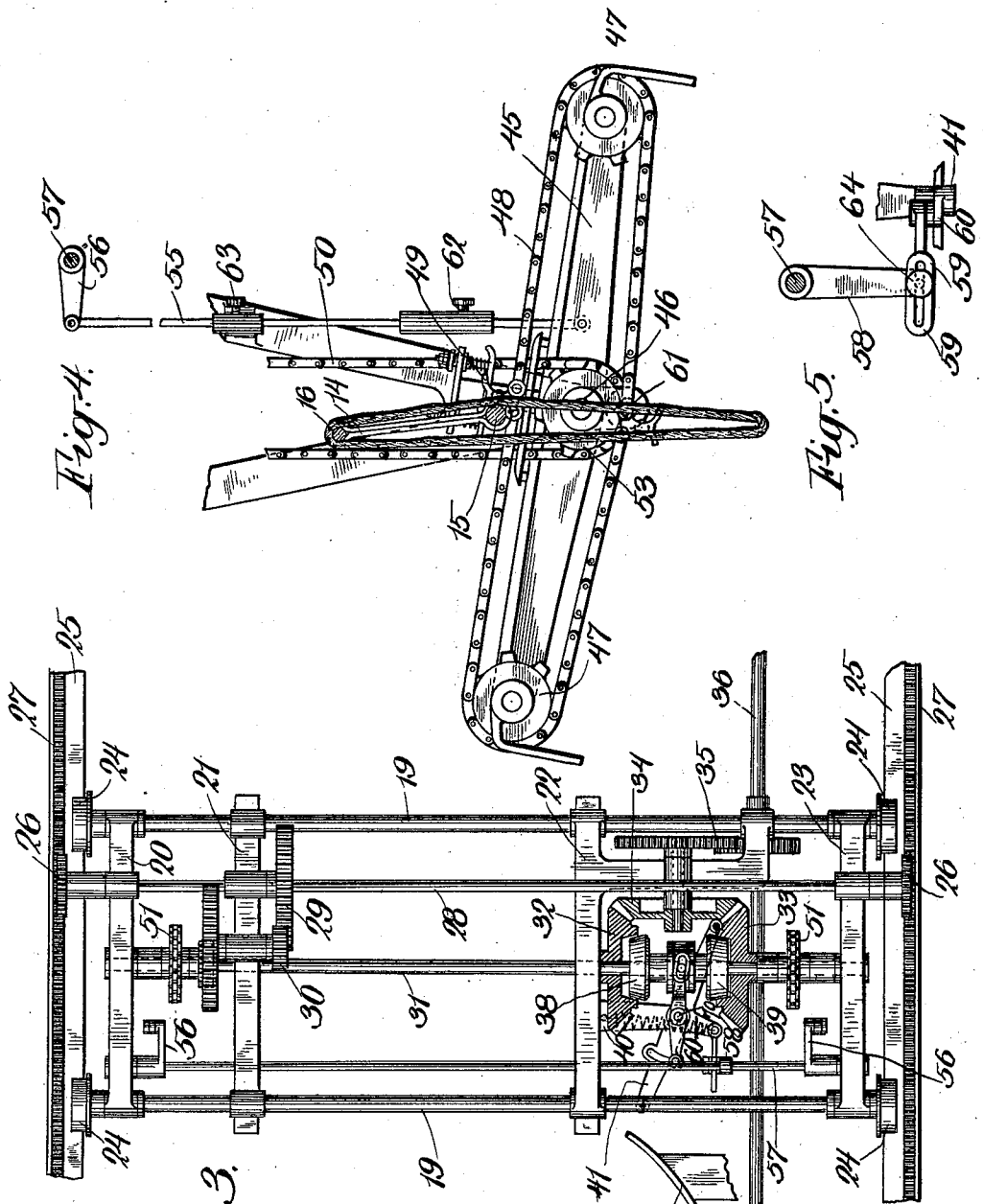

WITNESSES:  
*J. L. Hartmann*  
*W. Andrews Jr.*

INVENTOR  
*E. De Jorno*  
BY  
*Chapin Hayward*  
ATTORNEYS

E. DE JOURNO.  
DYEING APPARATUS.

APPLICATION FILED APR. 22, 1909.

1,000,589.

Patented Aug. 15, 1911.

4 SHEETS—SHEET 4.

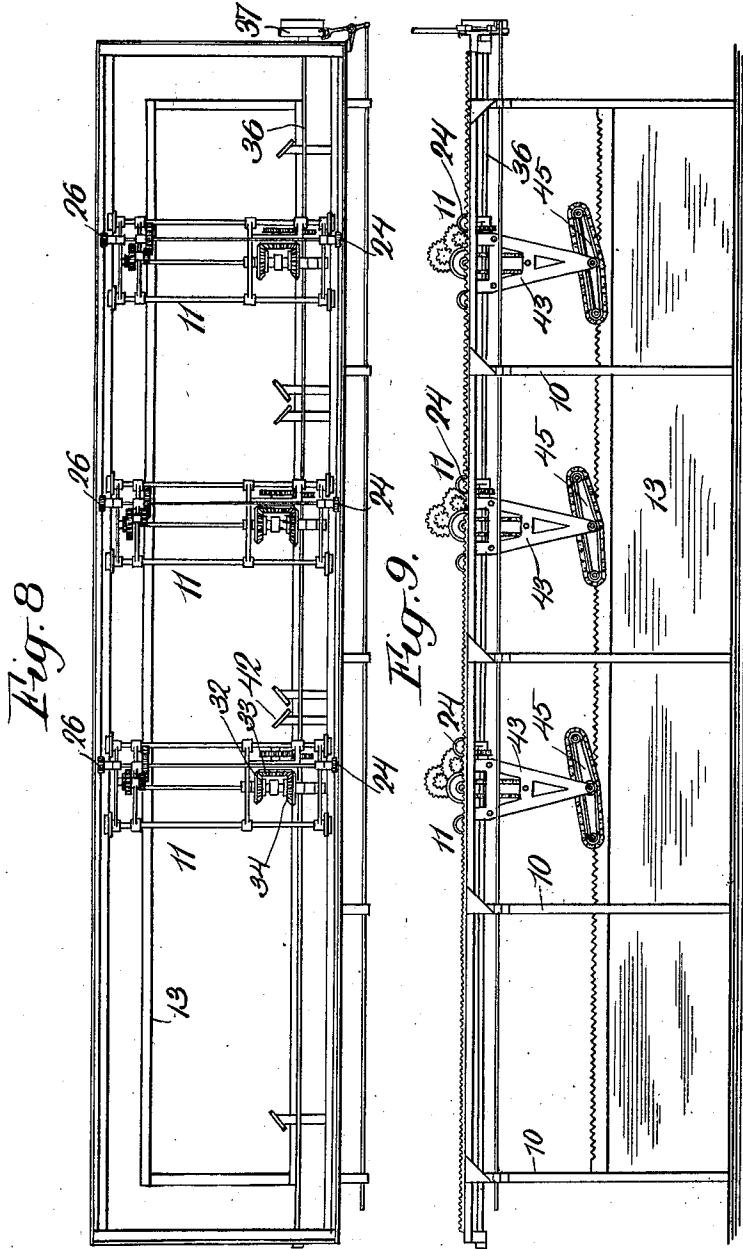

WITNESSES:  
*J. C. Hartmann*  
*H. Sandrews Jr.*

INVENTOR  
*Ernest de Jounno*  
BY  
*Chapin Haynes*  
his ATTORNEYS

# UNITED STATES PATENT OFFICE.

ERNEST DE JOURNO, OF ALLENTOWN, PENNSYLVANIA.

## DYEING APPARATUS.

1,000,589.

Specification of Letters Patent. Patented Aug. 15, 1911.

Application filed April 22, 1909. Serial No. 491,562.

*To all whom it may concern:*

Be it known that I, ERNEST DE JOURNO, a citizen of the United States of America, and a resident of Allentown, county of Lehigh, and State of Pennsylvania, have invented certain new and useful Improvements in Dyeing Apparatus, of which the following is a specification, reference being had to the accompanying drawings, forming a part thereof.

My invention relates to dyeing apparatus, and particularly to apparatus for dyeing silk in the skein.

The main object of my invention is to simulate hand dyeing as closely as possible, for the reason that heretofore such hand dyeing, particularly of silk skeins, has been very greatly superior to any dyeing effected by machinery. To this end I have provided an apparatus in which the various motions imparted to the skeins in their immersion in the dyeing vat, imitate as closely as possible the motions ordinarily made by the hand in hand dyeing.

In carrying out my invention I employ individual and independent carriers for the skeins, which, while adapted to be operated upon by the mechanism employed, are not permanently connected or attached in any way thereto whereby they may be readily removed and other carriers employed in their place. The advantages of this are many,—first, the carriers with the skeins hanging therefrom may be removed from the apparatus to a suitable place for drying or storage without the necessity of removing the skeins from the carriers; second, it obviates the necessity of cleaning the carriers every time a different color is employed in the dyeing apparatus, for different carriers may be employed for different colors; and third, it facilitates the placing of the skeins in position upon the carriers and the removal thereof from the carriers when required.

My invention consists in an improved form and construction of traveling carriage and means for operating the same, in a reversing means whereby the skeins are caused to travel backward and forward as in hand dyeing, and in many novel details of construction and combinations of parts, such as will be fully pointed out hereinafter, and in order that my invention may be fully understood, I will now proceed to describe an embodiment thereof, having reference to the accompanying drawings illustrating the

same, and will then point out the novel features in claims.

In the drawings: Figure 1 is a view in central vertical longitudinal section through the apparatus. Fig. 2 is a view in transverse section therethrough upon a somewhat larger scale, the lower portions of the dyeing vat and the supporting frame being broken away. Fig. 3 is a detail top view, with certain parts in horizontal section, of a traveling carriage employed, together with certain correlated parts. Fig. 4 is a detail view in sectional elevation of the carrier operating means. Fig. 5 is a detail view of certain parts of the shipping mechanism employed for changing the position of the carrier operating device. Fig. 6 is a detail view upon an enlarged scale of certain parts of the carrier operating device showing one of the carriers in a position to be rotated, at the same time a movement of translation is being imparted thereto. Fig. 7 is a detail top view of a portion of the link chain employed in the carrier operating device. Figs. 8 and 9 are respectively a top view and a view in side elevation of an apparatus employing a plurality of carrier operating mechanisms.

The apparatus as a whole comprises a suitable framework 10, a traveling carriage-11 supported thereby, a carrier operating mechanism 12 suspended from the said carriage, a dye vat 13, and a plurality of individual carriers 14 normally supported upon the edges of the vat but adapted to be picked up, and operated by, the operating mechanism 12. The carriers 14 each comprise a top rod 15 of a length somewhat greater than the width of the vat, a lower rod 16 whose length is somewhat less than the distance between the inner walls of the tank, and connecting side bars 17. The ends of the rods 15 are adapted to be received in notches in racks 18 secured to the edges of the tank (see Figs. 1 and 2), whereby they will be held against accidental displacement until they are intentionally removed. The skeins of silk or other material to be treated in the dyeing vat are threaded upon the carriers and are permitted to hang down suspended from the bar 15, while the carriers are thus held, as is clearly shown in Figs. 2 and 3, whereby the lower ends thereof will be contained within the dye in the vat 13.

The carriage 11 includes a framework composed of transverse tie rods 19 and

longitudinally disposed members 20—21—22—23. Flanged wheels 24 mounted upon the ends of the tie rods 19 are supported upon tracks 25 which form a part of the main frame 10 of the apparatus. Feeding movements longitudinal with respect to the apparatus are imparted to the carriage by means of pinions 26 which engage with stationary racks 27 secured to, or forming a part of, the framework 10 of the machine, the said pinions 26 being mounted fast upon a shaft 28 journaled in suitable bearings in the frame of the carriage 11, the said shaft having secured thereto a spur gear 29, the teeth of which engage a pinion 30 which constitutes a portion of a train of reducing gearing by which the shaft 28 is driven by a shaft 31 also journaled in the frame of the carriage 10. The shaft 31 has two bevel gear wheels 32—33 mounted loosely thereon, both of the said bevel gear wheels being arranged in mesh with a common bevel gear wheel 34 which is driven through gearing 35 by means of a longitudinally disposed shaft 36. The shaft 36 extends the whole length of the apparatus and is provided with suitable fast and loose drive pulleys 37 at the end thereof, and the gear of the train of gearing 35 which is upon the shaft 36 is provided with a spline connection therewith whereby the carriage 11 may move freely in a direction longitudinal with respect to the shaft 36 while the driving connection between the shaft 36 and the gearing 35 will be maintained. Clutch mechanism is provided for throwing either of the bevel gear wheels 32—33 into driving relation with the shaft 31, such clutch mechanism comprising two cones 38—39 splined upon the shaft 31 whereby they will always be in rotative connection therewith, but may have limited longitudinal movement thereon, the said cones being adapted to engage with conical recesses in the wheels 32—33 respectively. A shipping device 40, including a shipping lever 41, engages the said cones 38 and 39 and in its operation is adapted to move the cones in one direction or the other so that the cone 38 will engage the wheel 32, or the cone 39 will engage the wheel 33, at will. The shipping lever is pivotally mounted upon a vertical stud 70 carried by a bracket extending from the longitudinal element 22 of the carriage 11 and is adapted to move horizontally about such pivot. Stationary cam pieces 42 are provided at the desired points to engage the shipping lever 41 to operate the shipping device whereby to change the relative position of the cones, and hence to change the direction of the driving movements imparted to the carriage. These cam pieces 42 are preferably placed at the outside ends of the apparatus so that the carriage will be caused to travel backward and

forward from one end of the apparatus to the other, the direction of movement when the end of the apparatus is reached being automatically reversed by the action of the said stationary cam pieces upon the shipping mechanism, as will be well understood. The outer frame members 20 and 23 of the carriage 11 have downwardly extending portions 43 (see Figs. 2 and 3) connected together by cross ties 44, which constitute supporting means for the carrier-operating or transverse mechanism 12. This mechanism includes tilting frames 45, one on each side of the apparatus, the said frames being pivoted to the lower ends of the standards 43 upon studs or pins 46; sprocket wheels 47 rotatably mounted at the opposite ends of the said tilting frames 45; and a carrier chain 48 mounted upon the said sprocket wheels 47 and provided with carrier engaging elements or hooks 49. Motion is imparted to the chains 48 by means of vertical sprocket chains 50 which connect sprocket wheels 51 secured upon the carriage shaft 31 near its opposite ends, with sprocket wheels 52 mounted loosely upon the studs 46. Other sprocket wheels 53 mounted to rotate with the sprocket wheels 52 engage the links of the said chains 48 and so impart the driving movements which they receive through the chains 50 from the carriage shaft 11, to the said chains 48. It will be remembered that the shaft 31 rotates at a very much higher speed than does the shaft 28; therefore, though the carriage 11, as a whole, moves slowly from one end of the apparatus to the other the carrier chains 48 will, in the meantime, move quite rapidly. The carrier engaging elements or hooks 49 are arranged, in the movement of the carrier chains 48, to successively engage the ends of the bars 15 of the individual carriers 14, as appears more particularly in Fig. 1 of the drawings, the said hooks being arranged to carry the said carriers over the tilting frames 45 from the front to the rear ends thereof, and at the rear end of the same to deposit the carriers with their burdens at suitable points in succession to the rear of the said frames. Stationary guides 71 serve to guide the carriers as they leave the chains. This movement and the operation thereof will be best understood by reference to Fig. 1 in which it will be seen that a carrier is just being lifted by the transferring mechanism at the forward end of the tilting frames (considering the same to be moving in the direction of the arrow 54 in proximity thereto) and has just deposited a carrier with its burden at the rear thereof. As the carriage moves slowly in the direction of the arrow 54 the carriers with their burdens will be moved in succession from the front to the rear until the carriage

reaches the end of the apparatus. At this time the driving motion thereof will be reversed owing to the operation of the stationary cam piece 42 upon the shipping mechanism, and the carriage will then commence its return movement. In its return movement the transferring mechanism will proceed to transfer the carriers with the skeins thereon, one at a time, from one end of the transferring mechanism to the other, and such operation will be continuous until the carriage reaches the opposite end of the apparatus and the motion thereof is again reversed by engagement of the shipping mechanism with the stationary cam 42 as will be well understood.

At the moment of reversing the direction of movement of the carriage it is necessary also to reverse the tilted position of the frames 45, and for this purpose I have connected the said frames 45 by means of connecting rods 55 with arms 56 upon a rock shaft 57. The rock shaft 57 is provided with an operating arm 58 which connects by means of a link 59 with an arm 60 of the shipping lever 41. When the shipping lever 41 is shifted from one position to the other a corresponding movement is communicated through the said links and levers to tilt the frames 45 in the proper direction and at the proper angle.

Hand dyeing is usually carried on by shifting individual carriers, from which skeins hang suspended in the dyeing vat, from one position in the vat to another, and in such movements they are usually lifted somewhat. The lifting and transferring operation performed by the carrier operating mechanism 12 very closely simulates this movement. Sometimes, however, the carriers are hardly elevated at all, being lifted only just sufficient to clear the edges of the tank and then moved along from one position to the other. If it is desired to so do in the present apparatus the frames 45 are lowered and are maintained in a horizontal position. The amount of lift then given to the carriers is only just sufficient to allow them to clear the teeth of the racks 18 and thereafter they are moved horizontally instead of being moved along an incline as formerly. In order to lower the tilting frames 45 I have provided openings 61 at the lower extremities of the brackets or standards 43 for receiving the pivot pins 46. The pins may be removed from the positions which they normally occupy, to the said lower points, and the frames may be held permanently in a horizontal position by first loosening a coupling 62 with which the connecting rod 55 is provided whereby the frames may be adjusted to the required horizontal position and then securing the said connecting rod 55 fast to the frame piece 43 of the carriage 11 by means of a

set screw 63. At this time a coupling 64 provided between the operating arm 58 and the link 59 (see Fig. 5) must be disconnected so as to allow the operating arm 58 free movement while the link 59 is held still. 70

In the hand operation of dyeing a rotary movement is usually given to the carrier during its movement of translation from one end of the vat to the other, and to provide for a similar movement I employ a spring actuated presser bar 65, carried by the tilting frames intermediate their ends, and a relatively stationary track 66 opposite the said presser bar. The hooks 49 are provided with rollers 67 which engage the said tracks whereby the said rollers are rotated and the carrier bars 15 are forced against the said rollers 67 by means of the presser bars 65, whereby as the carriers pass the center of the tilting frames they will be given a movement of rotation. This mechanism is shown on an enlarged scale in detail in Fig. 6, while a carrier is shown as being thus rotated in the detail sectional view Fig. 4. The rotation of the carrier is brought about by the co-engagement of the bar 15 thereof with the wheels 67 and the lower face of the presser bars 65, as will be well understood. Should it be desired that no such rotary movement be imparted to the carriers the presser bars 65 may be lifted so that they will fail to engage the bars 15 of the carriers, and for the purpose of holding the said presser bars 65 in their elevated positions I have provided a hook 68 for each said presser bar, as is clearly shown in Fig. 6. 80 85 90 95 100

As it is common in the dyeing art to employ a very long vat and to employ several gangs of operators at various points along the same, I have designed an apparatus such as is shown in Figs. 8 and 9 by which similar operations may be carried on mechanically at the various points. Such an apparatus comprises a single drive shaft 36 and a plurality of carriages 11 all of which are engaged and operated thereby. These carriages may be located at various points and at different distances apart as may be desired, stationary cams 42 for each carriage being located at the proper positions to effect the reversal of the direction movement of the carriages so as to limit their range of movement, as will be well understood. 105 110 115

While I have described the foregoing apparatus as a "dyeing apparatus" and the liquid in the vat as a "dye," it will, of course, be understood that liquids of other character may be employed in the vat, if desired, and the apparatus used for other purposes besides dyeing,—such, for instance, as washing, cleaning, etc. 120 125

What I claim is:

1. In apparatus of the class described, the combination with a vat, of individual and 130

unattached carriers for suspending articles in the vat, a traveling carriage, means for imparting feeding movements to the carriage over the said vat and transferring means comprising endless chains carried by the said carriage, for imparting movements of translation to the said carriers.

2. In apparatus of the class described, the combination with a vat, of individual and unattached carriers for suspending articles in the vat, means for supporting the said carriers over the vat, a traveling carriage, means for imparting feeding movements to the carriage over the said vat, and transferring means carried by the said carriage for imparting movements of translation to the said carriers, said transferring means comprising endless chains arranged normally at an angle to the horizontal.

3. In apparatus of the class described, the combination with a vat, of individual and unattached carriers for suspending articles in the vat, a traveling carriage, means for imparting feeding movements alternately in opposite directions to the carriage over the said vat, and transferring means carried by the said carriage for imparting movements of translation to the said carriers, the said transferring means comprising endless chains arranged normally at an angle to the horizontal.

4. In apparatus of the class described, the combination with a vat, of individual and unattached carriers for suspending articles in the vat, a carriage arranged to travel over the vat, means for imparting such movements thereto, reversing means for reversing the direction of the said movements at predetermined points, and transferring means comprising endless chains carried by the said carriage for imparting movements of translation to the said carriers.

5. In apparatus of the class described, the combination with a vat, of individual and unattached carriers for suspending articles in the vat, a carriage, means for imparting feeding movements thereto alternately in opposite directions, transferring means carried by the said carriage for imparting movements of translation to the said carriers, the said transferring means comprising endless chains, and means carried thereby for engaging the said carriers.

6. In apparatus of the class described, the combination with a vat, of individual and unattached carriers for suspending articles in the vat, a carriage arranged to travel longitudinally with respect to the vat, tilting frames carried thereby, and endless chains carried by the said tilting frames, said endless chains provided with means for engaging the said carriers.

7. In apparatus of the class described, the combination with a vat, of individual and unattached carriers for suspending articles

in the vat, a carriage arranged to travel longitudinally with respect to the said vat, tilting frames carried thereby, endless chains carried by the tilting frames, the said endless chains provided with means for engaging the said carriers, and means for automatically tilting the said frame in opposite directions.

8. In apparatus of the class described, the combination with a vat, of individual and unattached carriers for suspending articles in the vat, a carriage arranged to travel longitudinally with respect to the said vat, means for reversing the direction of movement of the said carriage at predetermined points, tilting frames carried by the said carriage, means carried by the tilting frames for engaging the carriers and imparting movements of translation thereto independent of the feeding movements of the carriage, and means for oppositely tilting the frames when the direction of feeding movements of the carriage is reversed.

9. In apparatus of the class described, the combination with a vat, of individual and unattached carriers for suspending articles in the vat, a carriage arranged to travel longitudinally with respect to the vat, tilting frames carried thereby, endless chains carried by the said tilting frames, the said endless chains provided with means for engaging the said carriers, means for oppositely tilting the said frames, and means for rendering the said tilting means inoperative, and holding the frames against tilting when desired.

10. In apparatus of the class described, the combination with a vat, of individual and unattached carriers for suspending articles in the vat, means for supporting the said carriers over the vat, endless chain mechanism for imparting movements of translation to the carriers successively, supporting means for the endless chain mechanism and means for feeding the supporting means and the said endless chain mechanism bodily along the vat.

11. In apparatus of the class described, the combination with a vat, of individual and unattached carriers for suspending articles in the vat, means for supporting the said carriers over the vat, endless chain mechanism for imparting movements of translation to the carriers successively, means for rotating the carriers while they are engaged by the said endless chain mechanism, supporting means for the endless chain mechanism and means for feeding the supporting means and the said endless chain mechanism bodily along the vat.

12. In apparatus of the class described, the combination with a vat, of individual and unattached carriers for suspending articles in the vat, means for supporting the said carriers over the vat, endless chain

mechanism for imparting movements of translation to the carriers successively, a pressure device for pressing upon the carrier ends to rotate them during their movements of translation, supporting means for the endless chain mechanism, and means for feeding the supporting means and the said endless chain mechanism bodily along the vat.

10 13. In apparatus of the class described, the combination with a vat, of individual and unattached carriers for suspending articles in the vat, means for supporting the said carriers over the vat, endless chain  
15 mechanism for imparting movements of translation to the carriers successively, the said chains carrying rollers for engagement with the said carriers, said rollers being caused to rotate in the movement of the end-  
20 less chains, and presser bars for forcing the said carriers against the rollers whereby to cause the rotation of the said carriers during their movements of translation, and means for feeding the said endless chain mechanism  
25 bodily along the vat.

14. In apparatus of the class described, the combination with a vat, of individual and unattached carriers for suspending articles

in the vat, means for supporting the said carriers over the vat, endless chain mechanism for imparting movements of translation to the carriers successively, a pressure device for pressing upon the carrier ends to rotate them during their movements of translation, means for rendering the said pressure device inoperative at will, and means for feeding the said endless chain mechanism bodily along the vat.

15. In apparatus of the class described, the combination with a vat, of individual and unattached carriers for suspending articles in the vat, means for supporting the said carriers over the vat, means for imparting movements of translation to the carriers successively, rollers carried by the said means and arranged to rotate in such movements of translation, and a pressure device for forcing the carriers against the said rollers during their movements of translation to cause them to be rotated by the relative movement of the said rollers with respect to the said pressure device.

ERNEST DE JOURNO.

Witnesses:

D. HOWARD HAYWOOD,  
F. B. GRAVES.