

(19) World Intellectual Property Organization
International Bureau



(43) International Publication Date
3 July 2003 (03.07.2003)

PCT

(10) International Publication Number
WO 03/054389 A1

- (51) International Patent Classification⁷: F03D 11/02 // B29C 70/00 (SE). VAARA, Jan [SE/SE]; Klockartorpsvägen 38, S-582 75 Linköping (SE).
- (21) International Application Number: PCT/SE02/01997 (74) Agent: SAAB AB; Saab Aerospace, Technology Strategy and IPR, Margareta Ydreskog, SE-581 88 Linköping (SE).
- (22) International Filing Date: 4 November 2002 (04.11.2002) (81) Designated States (*national*): AE, AG, AL, AM, AT (utility model), AT, AU, AZ, BA, BB, BG, BR, BY, BZ, CA, CH, CN, CO, CR, CU, CZ (utility model), CZ, DE (utility model), DE, DK (utility model), DK, DM, DZ, EC, EE, ES, FI (utility model), FI, GB, GD, GE, GH, GM, HR, HU, ID, IL, IN, IS, JP, KE, KG, KP, KR, KZ, LC, LK, LR, LS, LT, LU, LV, MA, MD, MG, MK, MN, MW, MX, MZ, NO, NZ, OM, PH, PL, PT, RO, RU, SD, SE, SG, SI, SK (utility model), SK, SL, TJ, TM, TN, TR, TT, TZ, UA, UG, US, UZ, VN, YU, ZA, ZM, ZW.
- (25) Filing Language: English
- (26) Publication Language: English
- (30) Priority Data: 0103872-8 21 November 2001 (21.11.2001) SE
- (71) Applicant (*for all designated States except US*): SAAB AB [SE/SE]; S-581 88 Linköping (SE).
- (72) Inventors; and
- (75) Inventors/Applicants (*for US only*): KROGAGER, Max [SE/SE]; Nya Tanneforsvägen 88, S-582-42 Linköping
- (84) Designated States (*regional*): ARIPO patent (GH, GM, KE, LS, MW, MZ, SD, SL, SZ, TZ, UG, ZM, ZW), Eurasian patent (AM, AZ, BY, KG, KZ, MD, RU, TJ, TM), European patent (AT, BE, BG, CH, CY, CZ, DE, DK, EE, ES, FI, FR, GB, GR, IE, IT, LU, MC, NL, PT, SE, SK,

[Continued on next page]

(54) Title: DEVICE FOR OVERVOLTAGE PROTECTION IN A WIND TURBINE

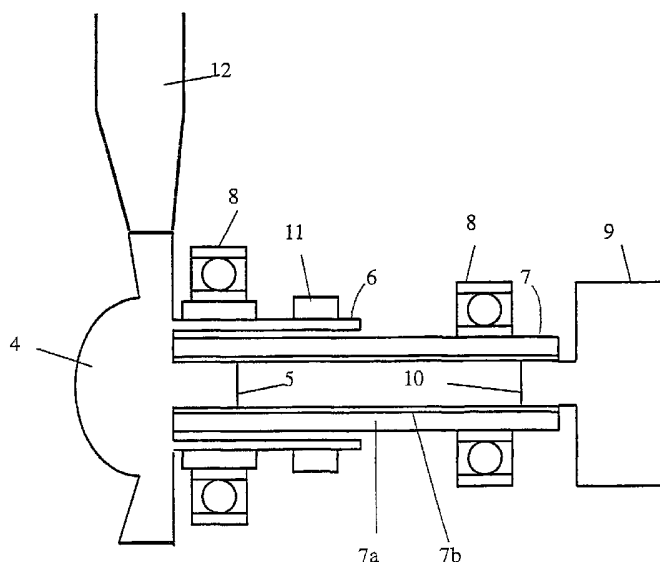

(57) Abstract: The invention concerns a device for overvoltage protection in a wind turbine comprising a drive shaft (7) that is arranged to operatively connect one or a plurality of rotor blades (12) to a generator (9). The invention includes a drive shaft (7) containing a core of carbon fiber composite (7a) with a longitudinally through-passing cavity. In one end a connector (5) for a hub (4) that connects the rotor blades (12) is arranged to be introduced, and in the other end a coupling part (10) to the generator (9) is arranged to be introduced. An inner layer of fiberglass composite (7b), which is integrated with a core of carbon fiber composite (7a) in the drive shaft (7), surrounds the cavity and is arranged so as to electrically insulate the connector (5) and the coupling (10) from the drive shaft (7), which is electrically connected to ground.



WO 03/054389 A1



TR), OAPI patent (BF, BJ, CF, CG, CI, CM, GA, GN, GQ, GW, ML, MR, NE, SN, TD, TG).

(AT, BE, BG, CH, CY, CZ, DE, DK, EE, ES, FI, FR, GB, GR, IE, IT, LU, MC, NL, PT, SE, SK, TR), OAPI patent (BF, BJ, CF, CG, CI, CM, GA, GN, GQ, GW, ML, MR, NE, SN, TD, TG)

Declarations under Rule 4.17:

— as to applicant's entitlement to apply for and be granted a patent (Rule 4.17(ii)) for the following designations AE, AG, AL, AM, AT, AU, AZ, BA, BB, BG, BR, BY, BZ, CA, CH, CN, CO, CR, CU, CZ, DE, DK, DM, DZ, EC, EE, ES, FI, GB, GD, GE, GH, GM, HR, HU, ID, IL, IN, IS, JP, KE, KG, KP, KR, KZ, LC, LK, LR, LS, LT, LU, LV, MA, MD, MG, MK, MN, MW, MX, MZ, NO, NZ, OM, PH, PL, PT, RO, RU, SD, SE, SG, SI, SK, SL, TJ, TM, TN, TR, TT, TZ, UA, UG, UZ, VN, YU, ZA, ZM, ZW, ARIPO patent (GH, GM, KE, LS, MW, MZ, SD, SL, SZ, TZ, UG, ZM, ZW), Eurasian patent (AM, AZ, BY, KG, KZ, MD, RU, TJ, TM), European patent

— as to the applicant's entitlement to claim the priority of the earlier application (Rule 4.17(iii)) for all designations
— of inventorship (Rule 4.17(iv)) for US only
— of inventorship (Rule 4.17(iv)) for US only

Published:

— with international search report

For two-letter codes and other abbreviations, refer to the "Guidance Notes on Codes and Abbreviations" appearing at the beginning of each regular issue of the PCT Gazette.

Device for Overvoltage Protection in a Wind Turbine

TECHNICAL AREA

The invention concerns a device for overvoltage protection in a wind turbine comprising a drive shaft that is arranged so as to operatively connect one or a plurality of rotor blades
5 to a generator.

STATE OF THE ART

Wind power plants generally consist of a tower with a wind turbine, which converts wind energy into electrical energy. The wind turbine comprises rotor blades, which connect to a
10 shaft that is connected to an electrical generator. The rotor blades transfer forces from the wind striking the blades to the shaft, and a generator can be caused to rotate thereby.

An effort is currently underway to increase the capacity of wind power plants by increasing their dimensions. Current wind power plants use a rotor shaft made of metal. This works
15 satisfactorily in smaller wind turbines but, in larger wind turbines, assumes such dimensions that the material is considered to be unsuitable for handling-related reasons. The use of fiber composite material in the shaft makes it possible to reduce the weight considerably, while at the same time achieving sufficient strength and rigidity.

20 The use of electrically conductive material in the rotor shaft entails a need for lightning protection or overvoltage protection for the generator itself, and for the bearings that support the rotary shaft. In the event of a lightning strike to the rotor blades, there is a risk that the current path will propagate through the rotor blades and the shaft and into the generator. It is important to protect the bearings and the generator from this current since,
25 e.g. bearing damage can lead to major problems in connection with repairs. The same is also true with regard to generator damage. Overvoltage protection, whereby the energy is conducted to ground potential in a controlled manner, is used to protect both generator and bearings.

30 SE, B, 429 279 describes a previously known overvoltage protection for a wind turbine. When such known overvoltage protection is used, the bearings and the generator are

insulated from the rotor shaft by means of a coating of insulating material. Each bearing lies in abutment with a bearing seat of high insulating capacity, which is fitted to the rotor shaft. To prevent the current path from passing into the generator, the generator shaft is equipped with insulating material in an area that connects to the rotor shaft. A lightning
5 discharge is conducted from the wind turbine via a spark discharge gap between a stationary and a moving part. One disadvantage of this known solution is that it imposes heavy loads on the connections between the shaft and its insulating layer, e.g. in connection with emergency braking, since the kinetic mass of the generator is substantial. There is a major risk that the insulating material will be torn away from the shaft.

10

DESCRIPTION OF THE INVENTION

One object of the invention is to simplify overvoltage protection in wind turbines, while at the same time utilizing a drive shaft that is suited for higher power levels. The device for overvoltage protection in a wind turbine comprises a drive shaft made of composite
15 material, which consists mainly of carbon fiber composite. The drive shaft has a longitudinally through-passing cavity. A connector to a hub connecting the rotor blades is arranged so as to be introduced into one end of the cavity. A coupling to the generator is arranged to be introduced into the second end. The cavity is surrounded by a layer of fiberglass composite that is integrally realized with the carbon fiber composite, which
20 fiberglass composite is arranged so as to electrically insulate the connector and the coupling from the carbon fiber composite of the drive shaft. The drive shaft is connected to ground.

In an embodiment of the invention, the drive shaft is arranged so as to rotate in at least two
25 bearings. These bearings lie in abutment with the drive shaft via a layer of fiberglass composite that is integrated with the carbon fiber composite. A slipring is arranged so as to conduct currents from the drive shaft to ground.

In an advantageous embodiment of the invention, the thickness of the fiberglass composite
30 may account for 2 - 10% of the thickness of the entire composite structure. Because each respective layer of fiberglass composite can be relatively thin in relation to the carbon fiber composite, the properties that render the carbon fiber composite suitable for use in large drive shafts are retained, while satisfactory insulation of the electrically conductive carbon

fiber composite is achieved at the same time.

In another embodiment of the invention, a thin layer of fiberglass composite is realized on the respective short sides of the drive shaft, so that each respective end of the drive shaft is
5 electrically insulated.

In yet another embodiment of the invention, a metallic guide is integrated with the hub. A slipring lies in abutment with the metallic guide, whereby currents in the hub are conducted to ground.
10

In an embodiment of the invention, an insulating layer is arranged between the metallic guide and a bearing adjacent thereto to prevent currents from being able to pass through the bearings.

15 BRIEF DESCRIPTION OF FIGURES

Figure 1 provides a schematic side view of a wind power plant.

Figure 2 provides a schematic view of a coupling between the rotor hub of the wind power plant and a generator.

Figure 3 shows another example of a coupling between a rotor hub and a generator.
20

PREFERRED EMBODIMENTS

Reference number 1 in Figure 1 generally designates a wind power plant consisting of a tower 2, a housing 3 arranged at the top of the tower, and a wind turbine arranged in the housing 3. The tower 2 is secured to a surface, either on land or at sea.
25

The parts of the wind turbine that are essential to the invention are shown in Figure 2. The rotor blades 12 are operatively connected to a generator 9 so that a torque applied to the rotor blades 12 is converted into electrical current in the generator. The rotor blades 12 are securely fastened to a drive shaft 7 in the wind turbine via a hub 4. A connector 5 connects
30 the hub 4 to the drive shaft 7 in such a way that, when the rotor blades 12 begin to rotate, the rotational motion is also imparted to the drive shaft 7. A coupling 10 connects the generator 9 to the drive shaft 7. The rotational motion is thereby transferred from the drive

shaft 7 to the generator 9, which converts the rotational energy of the shaft into electrical energy. The way in which the generator 9 is constructed is not the object of this invention. What is essential is that the drive shaft 7 has an operative connection to the generator 9 via a coupling 10, which may constitute a part of the generator 9 in an embodiment.

5

The drive shaft 7 consists of a cylindrical body with a longitudinally through-passing cavity. In large wind turbines it is advantageous, from a weight standpoint, to allow the cavity to be through-passing and to have the greatest possible diameter, since this results in substantially lower weight. The main part of the drive shaft 7 consists of a core of carbon fiber composite 7a.

10

The fiber composite material is composed of a plastic base reinforced with carbon fiber threads. The plastic is, e.g. an epoxy plastic, vinylester plastic or polyester plastic. This material provides a number of desirable properties, in that such material is light, very strong, and rigid. In the embodiment shown in Figure 2, an inner layer of fiber glass composite 7b is integrally realized with the carbon fiber composite along the inside diameter of the drive shaft 7 so that the inner layer of the fiberglass composite 7b delimits the cavity. The fiberglass composite is an electrically insulating material, and the drive shaft 7 is insulated from the inner cavity thereby. The core of the carbon fiber composite 7a and the respective layers 7b and 7c of fiber glass composite consist of a plurality of thin layers of composite material arranged on top of one another - often with different fiber orientations - which are joined in an autoclave press to produce an integrated structure.

15

20

By integrating one or a plurality of fiberglass composite layers with the carbon fiber composite in conjunction with the fabrication of the drive shaft 7, the risk that the insulating layer will separate from the shaft is eliminated. The integrated layer of fiberglass composite comprises a part of the drive shaft 7 and thus contributes to bearing the load on the shaft.

25

A metallic hub 4 connects the rotor blades 12 to the drive shaft by means of a connector 5, which is realized in one piece with the hub 4, or connected thereto in some other way. The connector 5 holds the hub 4 to the drive shaft 7 by means of a press-fit. The joint 13 between the connector 5 and the drive shaft 7 can also consist of other types of joints, such

30

as adhesive joints or bolt joints, as shown in Figure 3. The connector 5 connects the hub 4 to the drive shaft 7 in such a way that, when the hub 4 begins to rotate, the rotational motion is also imparted to the drive shaft 7. In its mounted state, the connector 5 lies in abutment with the insulating inner layer of fiberglass composite 7b.

5

In the embodiment shown in Figure 2, the hub 4 also comprises a guide 6, which is either realized in one piece with the hub 4 or constitutes a separate part that is mounted on the hub 4. The guide 6 extends from the hub 4 on the outside of the drive shaft 7 and includes a wall that is designed so as to surround, with play, the drive shaft 7 along a portion of the length of the drive shaft 7. The guide 6 is intended to hold the hub 4 in position relative to the drive shaft 7, and to permit its unimpeded rotation.

Bearings 8 are arranged along the length of the drive shaft 7, which bearings 8 hold the drive shaft 7 in its position, and in which bearings the drive shaft 7 rotates. In the embodiment shown in Figure 2, a first bearing 8 can surround the guide 6 of the hub 4, which guide is thereby caused to rotate in the bearing. A second bearing 8 surrounds the drive shaft 7 itself at a point nearer to the generator 9. The bearings and, above all, the bearing surfaces are sensitive to heavy currents, which makes it necessary to protect these surfaces from the heavy currents that can arise in connection with a lightning discharge.

20

An electrically insulating layer of, preferably, fiberglass composite is arranged between each respective bearing 8 and the part against which that bearing lies in abutment. In those cases where the bearings lie in direct abutment with the drive shaft 7, an insulating outer layer of fiberglass composite 7c is integrally realized with the carbon fiber composite on the outside of the drive shaft 7 so that the drive shaft wholly or partly exhibits an outside layer of fiber glass composite. The bearings are thereby insulated from those surfaces that could potentially be electrically conductive.

25

The inner layer of fiberglass composite 7b of the drive shaft insulates the generator 9 connected at the end from any current passing via the electrically conductive carbon fiber composite. To ensure that no current path into the generator 9 can arise, there is no contact between the coupling 10 to the generator 9 and the drive shaft 7. This is achieved by means of an air gap or beveling at the end surface on the drive shaft 7. It is also possible to coat

30

the two end surfaces of the drive shaft 7 with fiberglass composite so that the entire drive shaft 7 becomes electrically insulated, despite its core of electrically conductive carbon fiber composite. Because the drive shaft 7 consists of fiber composite, the joint described in Swedish patent application SE0103610-2 "Device and method for a drive shaft" can be used.

In the embodiment shown in Figure 2 a slipring 11 can lie in abutment with the mechanical guide 6. The slipring 11 connects to a ground potential and thus constitutes the natural current path for a current entering via the rotor blades 12.

10

A lightning discharge is described below in connection with the embodiment shown in Figure 2. When lightning strikes a wind turbine, a current path arises via the rotor blades 12 and into the hub 4 of the wind turbine. Using the device according to the invention, the electrical current is conducted via the guide 6 and the slipring 11, which constitute the easiest path for the current to follow to ground. On the generator side, contact is present only between the inner layer of fiberglass composite 7b on the drive shaft 7 and the generator 9. This prevents any type of current path from continuing on into the generator 9.

15

Figure 3 shows a wind turbine where the hub 4 is securely fastened to the drive shaft by means of a bolt joint 13. The bolts in this case are electrically conductive, and a current path could consequently arise in the carbon fiber composite. This current is however diverted via a slipring 11, which can lie in abutment with a portion of the carbon fiber core 7a in the drive shaft 7. The figure does not show the insulating layers that should be present in direct connection to each bearing 8 to further decrease the risk that the current path will propagate through the bearings.

20

25

LIST OF REFERENCE DESIGNATIONS

| | | |
|----|-------------------------------------|----|
| | Wind power plant | 1 |
| | Tower | 2 |
| | Housing | 3 |
| 5 | Hub | 4 |
| | Connector | 5 |
| | Guide | 6 |
| | Drive shaft | 7 |
| | Core of carbon fiber composite | 8 |
| 10 | Inner layer of fiberglass composite | 9 |
| | Outer layer of fiberglass composite | 10 |
| | Bearing | 8 |
| | Generator | 9 |
| | Coupling | 10 |
| 15 | Slipring | 11 |
| | Rotor blade | 12 |
| | Joint | 13 |

CLAIMS

1. A device for overvoltage protection in a wind turbine comprising a drive shaft (7) that is arranged so as to operatively connect one or a plurality of rotor blades (12) to a generator (9), **characterized in that**
- 5 - the drive shaft (7) contains a core of carbon fiber composite (7a),
- the drive shaft (7) contains a longitudinally through-passing cavity, in one end of which a connector (5) for a hub (4) that connects the rotor blades (12) is arranged to be introduced, and in the other end of which a coupling (10) to the generator (9) is arranged to be introduced,
- 10 - the drive shaft (7) also contains an inner layer of fiberglass composite (7b) that surrounds the cavity and is integrated with the core of carbon fiber composite (7a) in the drive shaft (7) so as to electrically insulate the connector (5) and the coupling (10) from the drive shaft, and
- the drive shaft (7) is electrically connected to ground.
- 15
2. A device according to claim 1, **characterized in that** the drive shaft (7) is arranged so as to rotate in at least two bearings 8, which lie in abutment with the drive shaft (7) via an electrically insulating material, and in that at least one slipring (11) lies in abutment with the drive shaft (7), whereupon currents through the drive shaft (7)
- 20 are diverted to ground.
3. A device according to claim 1, **characterized in that** the thickness of the inner layer of fiberglass composite (7b) accounts for 2 - 10% of the thickness of the entire composite structure.
- 25
4. A device according to claim 3, **characterized in that** the inner layer of fiberglass composite (7b) is arranged so as to extend along the short sides of the drive shaft (7) so that each respective end of the drive shaft (7) is electrically insulated.

5. A device according to claim 1, **characterized in that** a metallic guide (6) is integrated with the hub (4), and in that a slipring (11) lies in abutment with the metallic guide (6), whereby currents in the hub (4) are diverted to ground.
 - 5 6. A device according to claim 6, **characterized in that** an insulating layer is arranged between the metallic guide (6) and a bearing (8) adjacent thereto.
 7. A device according to claim 1, **characterized in that** an outer layer of fiberglass composite (7c) is arranged so as to surround the drive shaft (7) along the outside diameter of the drive shaft.
- 10

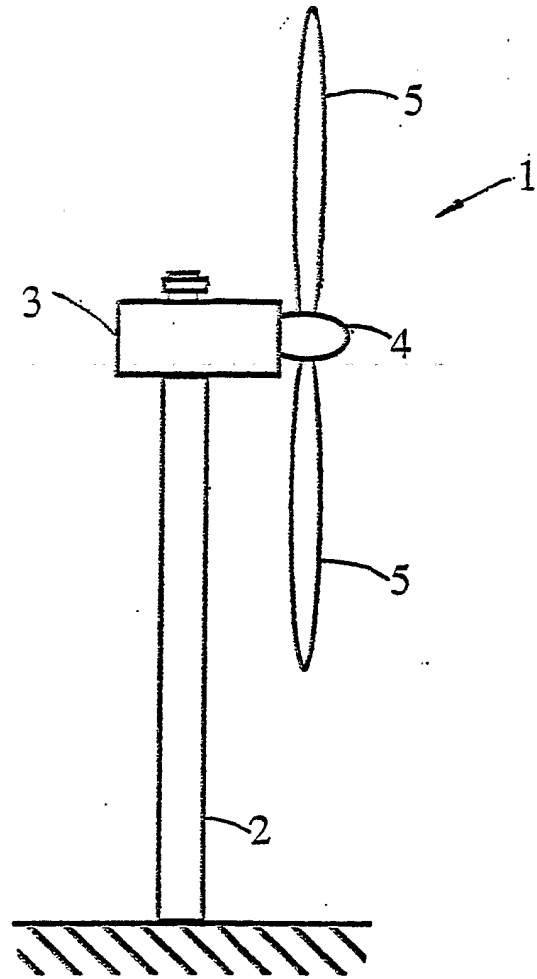

Fig 1

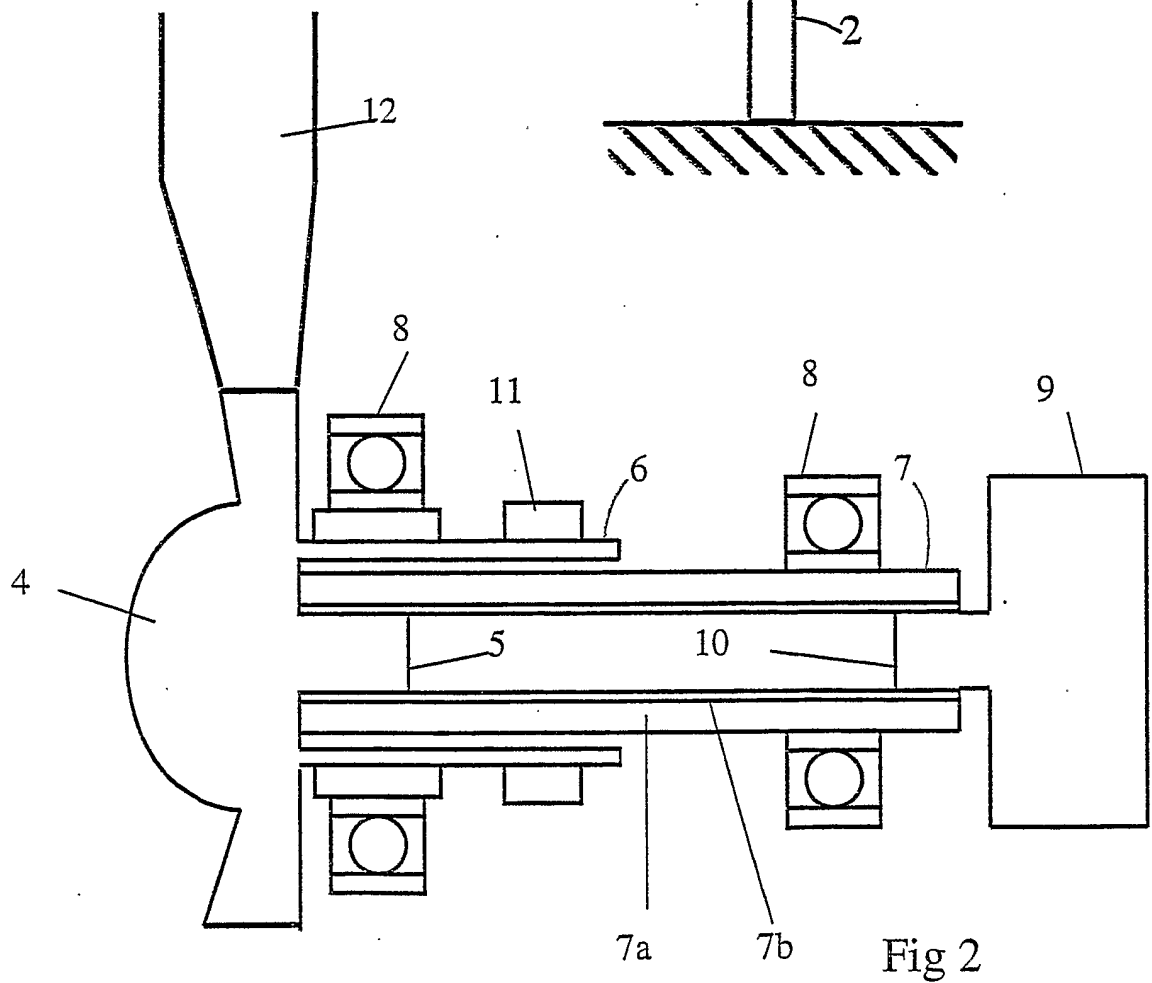

Fig 2

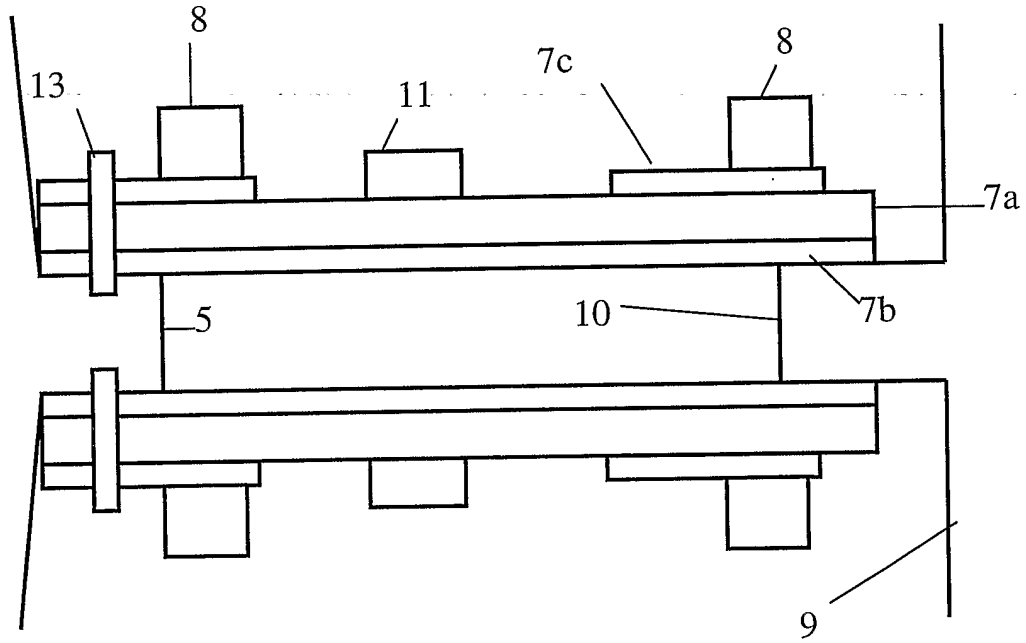

Fig 3

INTERNATIONAL SEARCH REPORT

International application No.

PCT/SE 02/01997

A. CLASSIFICATION OF SUBJECT MATTER

IPC7: F03D 11/02 // B29C 70/00

According to International Patent Classification (IPC) or to both national classification and IPC

B. FIELDS SEARCHED

Minimum documentation searched (classification system followed by classification symbols)

IPC7: F03D, B29C

Documentation searched other than minimum documentation to the extent that such documents are included in the fields searched

SE,DK,FI,NO classes as above

Electronic data base consulted during the international search (name of data base and, where practicable, search terms used)

EPO-INTERNAL, WPI DATA, PAJ

C. DOCUMENTS CONSIDERED TO BE RELEVANT

| Category* | Citation of document, with indication, where appropriate, of the relevant passages | Relevant to claim No. |
|-----------|--|-----------------------|
| A | EP 1036937 A2 (HITACHI, LTD ET AL), 20 Sept 2000 (20.09.00) -- | 1-7 |
| A | DE 4436197 A1 (WOBEN, ALOYS), 18 April 1996 (18.04.96) -- | 1-7 |
| A | WO 0177527 A1 (JOMITEK APS), 18 October 2001 (18.10.01) -- ----- | 1-7 |



Further documents are listed in the continuation of Box C.



See patent family annex.

* Special categories of cited documents:

"A" document defining the general state of the art which is not considered to be of particular relevance

"E" earlier application or patent but published on or after the international filing date

"L" document which may throw doubts on priority claim(s) or which is cited to establish the publication date of another citation or other special reason (as specified)

"O" document referring to an oral disclosure, use, exhibition or other means

"P" document published prior to the international filing date but later than the priority date claimed

"T" later document published after the international filing date or priority date and not in conflict with the application but cited to understand the principle or theory underlying the invention

"X" document of particular relevance: the claimed invention cannot be considered novel or cannot be considered to involve an inventive step when the document is taken alone

"Y" document of particular relevance: the claimed invention cannot be considered to involve an inventive step when the document is combined with one or more other such documents, such combination being obvious to a person skilled in the art

"&" document member of the same patent family

Date of the actual completion of the international search

4 February 2003

Date of mailing of the international search report

11-02-2003

Name and mailing address of the ISA/

Swedish Patent Office

Box 5055, S-102 42 STOCKHOLM

Facsimile No. +46 8 666 02 86

Authorized officer

Anna R-Salomonsson/EK

Telephone No. +46 8 782 25 00

INTERNATIONAL SEARCH REPORT

Information on patent family members

30/12/02

International application No.

PCT/SE 02/01997

| Patent document cited in search report | Publication date | Patent family member(s) | Publication date |
|--|------------------|---------------------------------|----------------------|
| EP 1036937 A2 | 20/09/00 | JP 2000265938 A US 6407900 B | 26/09/00 18/06/02 |
| DE 4436197 A1 | 18/04/96 | NONE | |
| WO 0177527 A1 | 18/10/01 | AU 4828301 A | 23/10/01 |