



US00D994604S

(12) **United States Design Patent**
Wang

(10) **Patent No.:** **US D994,604 S**

(45) **Date of Patent:** **** Aug. 8, 2023**

(54) **ACTUATOR VANE SHAFT**

D852,684 S * 7/2019 Carlini D12/159
D880,989 S * 4/2020 Hashimoto D8/360
D902,252 S * 11/2020 Joshi D15/5

(71) Applicant: **Easytork Automation Corporation**,
Maryland Heights, MO (US)

(Continued)

(72) Inventor: **George Wang**, Maryland Heights, MO
(US)

OTHER PUBLICATIONS

Caps. (Design—© Questel) orbit.com. [Online PDF compilation of
references] 71 pgs. Print Dates Range Oct. 14, 2020-May 15, 2007
[Retrieved Mar. 31, 2022].*

(**) Term: **15 Years**

(Continued)

(21) Appl. No.: **29/752,269**

(22) Filed: **Sep. 25, 2020**

Primary Examiner — George D. Kirschbaum

Assistant Examiner — Suzanne E Tisdell

(51) **LOC (14) Cl.** **13-02**

(74) *Attorney, Agent, or Firm* — Polsinelli PC

(52) **U.S. Cl.**

(57) **CLAIM**

USPC **D13/118**

The ornamental design for an actuator vane shaft, as shown
and described.

(58) **Field of Classification Search**

DESCRIPTION

USPC D15/1-6, 7-9, 14, 16, 28, 29, 72, 89,
D15/130, 142, 148, 149; D12/122-123;
D13/118; D32/1, 3, 5, 7, 13, 14, 19, 21,
D32/23, 25, 27, 29, 32, 33, 35; D8/382,
D8/383, 385, 386, 387, 394, 397, 399;
D18/10, 34.2, 34.8, 40, 46, 58; D23/231,
D23/232, 225

FIG. 1 is a front elevation view of an actuator vane shaft;
FIG. 2 is a left side thereof;
FIG. 3 is a rear elevation view thereof;
FIG. 4 is a right side view thereof;
FIG. 5 is a cross-section view thereof, viewed along line
2-2;

CPC F01L 2013/0052; F01L 2001/0535; F01L
2001/0473; F01L 1/047; F01L 1/344;
F16C 3/02; F16C 3/06; F16C 3/18

FIG. 6 is a top view thereof;
FIG. 7 is a bottom view thereof;
FIG. 8 is a top view thereof, shown within the unclaimed
environment of an actuator; and,
FIG. 9 is a front elevation view thereof, shown within the
unclaimed environment of an actuator.

See application file for complete search history.

The broken dashed lines (- - -) showing in FIGS. 1-7 are
included for illustrating portions of the actuator vane shaft
that form no part of the claimed design;

(56) **References Cited**

U.S. PATENT DOCUMENTS

D631,066 S * 1/2011 Itadani D15/9
D678,337 S * 3/2013 Yamamoto D15/5
D710,062 S * 7/2014 Ishibashi D32/25
D728,177 S * 4/2015 Ishibashi D8/399
D735,427 S * 7/2015 Ishibashi D32/35
D742,214 S * 11/2015 Yuan D8/399
D767,375 S * 9/2016 Nakano D8/360
D816,192 S * 4/2018 Sato D8/382
D836,740 S * 12/2018 Cameron D21/753

The broken long dash- short dash lines (- - -) showing in
FIGS. 8 and 9 are included for illustrating portions of the
actuator vane shaft that form no part of the claimed design;
while the broken dashed lines (- - -) are included for
unclaimed environmental structures.

1 Claim, 3 Drawing Sheets

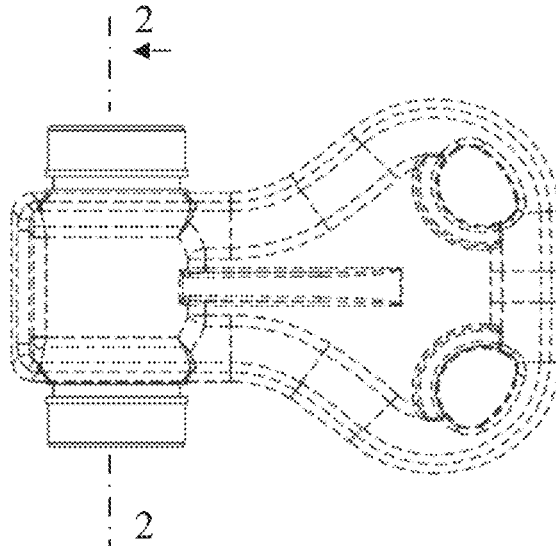

(56)

References Cited

U.S. PATENT DOCUMENTS

D913,336 S * 3/2021 Joshi D15/5

OTHER PUBLICATIONS

Vane, Shaft and Seal Design: The Critical Difference in Pneumatic Rotary Valve Actuators. Nov. 2017. Kinetrol. <https://vane-actuator.kinetrolusa.com/2017/11/vane-shaft-and-seal-design-critical.html>.*

Rotary actuator. 2014. Trivaco. https://www.trivaco.com/media/2122/rotary_actuator_2014_lr.pdf.*

Rotary Actuator Basics. Apr. 14, 2020. Mor Endustri. <https://www.morendustri.com/en/rotary-actuator-basics/>.*

* cited by examiner

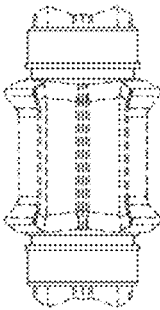
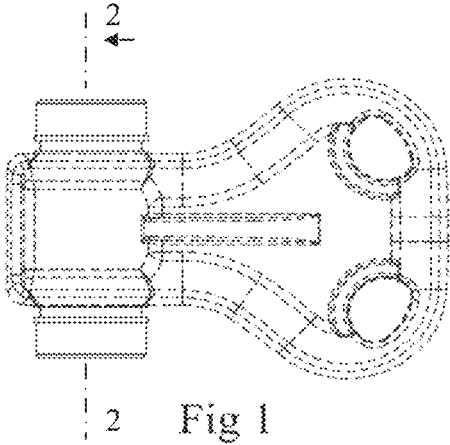

Fig 2

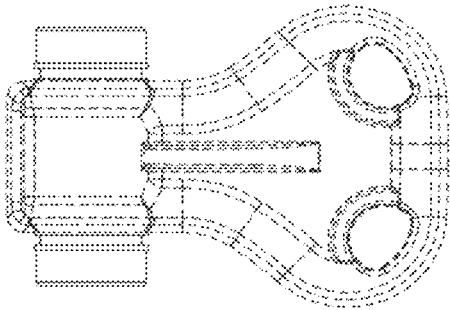

Fig 3

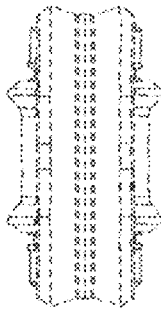

Fig 4

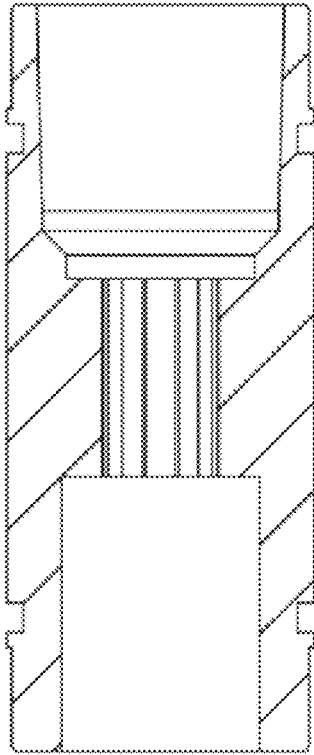

Fig 5



Fig 6

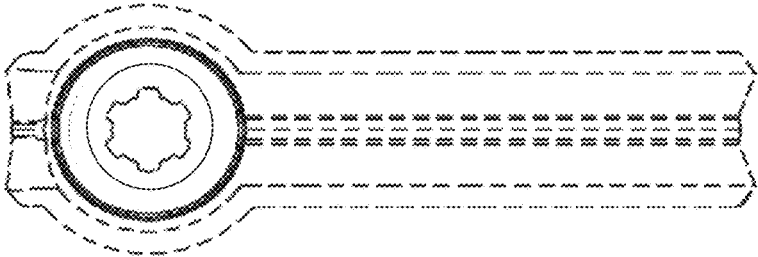

Fig 7

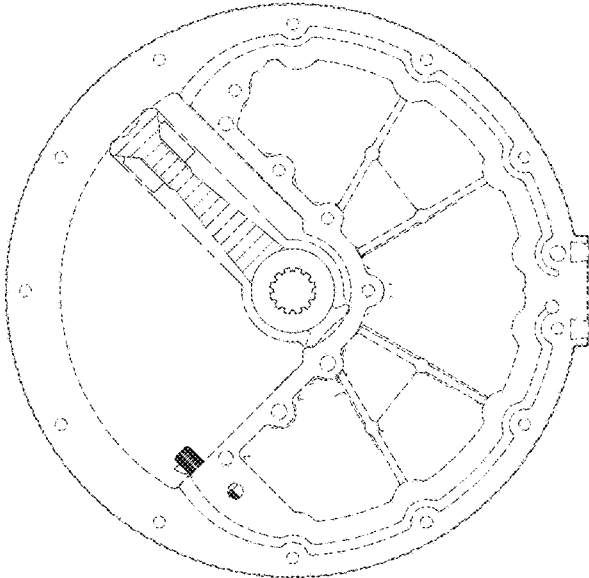

Fig 8

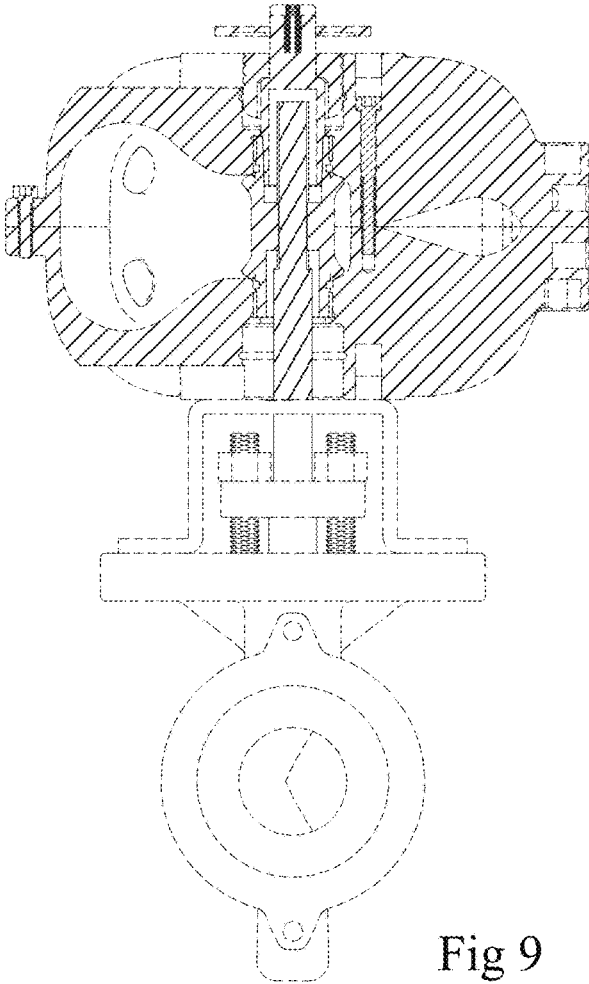

Fig 9