

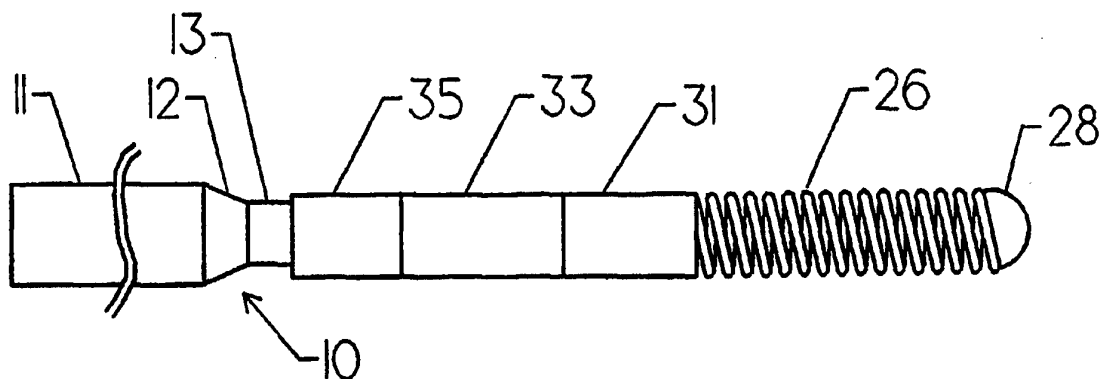

## INTERNATIONAL APPLICATION PUBLISHED UNDER THE PATENT COOPERATION TREATY (PCT)

(51) International Patent Classification <sup>6</sup> : <b>A61M 25/01</b>	<b>A1</b>	(11) International Publication Number: <b>WO 95/31244</b> (43) International Publication Date: 23 November 1995 (23.11.95)
<p>(21) International Application Number: PCT/US95/06226</p> <p>(22) International Filing Date: 18 May 1995 (18.05.95)</p> <p>(30) Priority Data: 08/245,339 18 May 1994 (18.05.94) US</p> <p>(71) Applicant: SCIMED LIFE SYSTEMS, INC. [US/US]; One Scimed Place, Maple Grove, MN 55311-1566 (US).</p> <p>(72) Inventor: PRATHER, Richard, R.; 5730 Nelmark Avenue, N.E., Rogers, MN 55374 (US).</p> <p>(74) Agents: GAFNER, Peter, J. et al.; One Scimed Place, Mail Stop A150, Maple Grove, MN 55311-1566 (US).</p>	<p>(81) Designated States: CA, JP, European patent (AT, BE, CH, DE, DK, ES, FR, GB, GR, IE, IT, LU, MC, NL, PT, SE).</p> <p><b>Published</b> <i>With international search report. Before the expiration of the time limit for amending the claims and to be republished in the event of the receipt of amendments.</i></p>	

(54) Title: CATHETER GUIDE WIRE WITH MULTIPLE RADIOPACITY



## (57) Abstract

An apparatus and method for a thin, flexible catheter guide wire having portions of uniform and tapering diameters, a helical coil of a first radiopacity encasing or covering the distal end of the wire, and at least one additional wire cover of a lubricious material which is formed to be radiopaque but which has a radiopacity different than that of the helical coil. This improved device enables the use of an improved method of placement with the use of fluoroscopy to steer and locate the guide wire, and thus the catheter ultimately placed over the guide wire, at a precise situs within the body.

**FOR THE PURPOSES OF INFORMATION ONLY**

Codes used to identify States party to the PCT on the front pages of pamphlets publishing international applications under the PCT.

AT	Austria	GB	United Kingdom	MR	Mauritania
AU	Australia	GE	Georgia	MW	Malawi
BB	Barbados	GN	Guinea	NE	Niger
BE	Belgium	GR	Greece	NL	Netherlands
BF	Burkina Faso	HU	Hungary	NO	Norway
BG	Bulgaria	IE	Ireland	NZ	New Zealand
BJ	Benin	IT	Italy	PL	Poland
BR	Brazil	JP	Japan	PT	Portugal
BY	Belarus	KE	Kenya	RO	Romania
CA	Canada	KG	Kyrgystan	RU	Russian Federation
CF	Central African Republic	KP	Democratic People's Republic of Korea	SD	Sudan
CG	Congo	KR	Republic of Korea	SE	Sweden
CH	Switzerland	KZ	Kazakhstan	SI	Slovenia
CI	Côte d'Ivoire	LI	Liechtenstein	SK	Slovakia
CM	Cameroon	LU	Luxembourg	SN	Senegal
CN	China	LK	Sri Lanka	TD	Chad
CS	Czechoslovakia	LV	Latvia	TG	Togo
CZ	Czech Republic	MC	Monaco	TJ	Tajikistan
DE	Germany	MD	Republic of Moldova	TT	Trinidad and Tobago
DK	Denmark	MG	Madagascar	UA	Ukraine
ES	Spain	ML	Mali	US	United States of America
FI	Finland	MN	Mongolia	UZ	Uzbekistan
FR	France			VN	Viet Nam
GA	Gabon				

## CATHETER GUIDE WIRE WITH MULTIPLE RADIOPACITY

### Background of the Invention

#### 1. Field of the Invention

5 The present invention relates in general to medical instrumentation, and more particularly to intraluminal devices, and still more particularly to guide wires for intraluminal devices including catheters.

#### 2. Description of the Prior Art

10 The use of intraluminal catheters for treatment of various medical problems within the body is well known. It is also well known that a variety of problems are encountered as the catheter is steered through the selected lumen to a desired point in the body. The path may be tortuous and the point of interest may be difficult to locate precisely. A continuing series of technical improvements and additions have been made in the catheter field to provide devices and methods which can overcome certain of the difficulties. One such  
15 series of improvements has resulted in the now well known use of a thin flexible guide wire which includes a radiopaque tip or distal portion and which can be more easily steered through the lumen and which can be more precisely placed with the use of a fluoroscope to read the location of the tip. A desired catheter can then be slid over the guide wire to reach the desired situs  
20 in the body.

U.S. Patent No. 3,789,841, for example, teaches the use of a guide wire having portions of uniform diameter adjacent to portions of tapered diameter to provide increase flexibility. The teaching includes encasing the distal end of the guide wire in a coiled spring and the remainder of the wire in a Teflon  
25 jacket.

U.S. Patent No. 4,545,390, for example, also teaches the use of a thin guide having both uniform and tapered diameter portions and having a helically wound spring encasing a tapered portion at its distal end. In this teaching, at least part of the spring is formed from a material having a high  
30 degree of radiopacity for the purpose of fluoroscopic observation.

U.S. Patent No. 4,884,579, for example, teaches yet another version of the above described thin, flexible guide wire that has a portion encased in a lubricious material such as Teflon to facilitate the passage of a catheter over the wire after it has been situated in the body.

U.S. Patent No. 5,201,754 teaches the use of varying radiopacity in an angioplasty balloon catheter to better enable its steerage through a body lumen.

#### SUMMARY OF THE INVENTION

5 The present invention adds to the improvements of the prior art by providing a thin, flexible catheter guide wire having portions of uniform and tapering diameters, a helical coil of a first radiopacity encasing or covering the distal end of the wire, and at least one additional wire cover of lubricious material which is formed to be radiopaque but which has a radiopacity  
10 different than that of the helical coil. This improved device enables the use of an improved method of placement with the use of fluoroscopy to steer and locate the guide wire, and thus the catheter ultimately placed over the guide wire, at a precise situs within the body.

#### BRIEF DESCRIPTION OF THE DRAWINGS

15 The objects and many of the attendant advantages of the present invention will be readily appreciated as it becomes better understood by reference to the following detailed description when considered in connection with the accompanying drawings, in which like reference numerals designate like parts throughout the figures thereof and wherein:

20 Fig. 1 is a plan view showing a thin, flexible wire having alternating portions of uniform and tapering diameters, and representing the preferred guide wire of this invention;

Fig. 2 is a plan view of one preferred embodiment of the invention showing a helical coil and a lubricious member covering a portion of the wire  
25 of Fig. 1; and

Fig. 3 is a plan view of a second preferred embodiment of this invention in which a plurality of lubricious wire covers are used.

#### DETAILED DESCRIPTION OF THE PREFERRED EMBODIMENTS

Fig. 1 discloses a catheter guide wire indicated generally at 10. Wire 10  
30 has a plurality of steps of uniform diameters 11, 13, 15 and 17, alternately interspersed with a plurality of steps of tapering diameter 12, 14, 16 and 18. The use of steps such as 11-19 is known in the art for the purpose of adding flexibility and ease of steerage to the guide wire. Step 11 is at the proximal end of wire 10, where the steering is initiated, while step 19 is at the distal end  
35 of wire 10 where the greatest flexibility is desired. As shown in Fig. 1, step 19 is connected at its distal end to a tip construction component indicated at 20.

Construction component 20 is adapted to be utilized in a tip member such as a ball-tip to protect the lumen walls as guide wire 10 is passed therethrough to reach its destination within the body.

5 Fig. 2 discloses a tip member 28 which has been formed with tip construction component 20 (not shown in Fig. 2). Also shown is a helical coil 26 which is mounted over the wire 10 and extends proximately from member 28. For purposes of clarity, any portion of wire 10 which might be visible within coil 26 has been omitted from Fig. 2, but reference to Fig. 1 will make clear the portion of wire 10 that is covered by coil 26. Coil 26 is flexible and at  
10 at least a portion of coil 26 is made of a material, such as that having a first radiopacity, in a manner known to those familiar with the prior art.

Fig. 2 also discloses a wire covering member 24, shown here as a sleeve, which is mounted on wire 10 and extends proximately from coil 26 to cover a selected portion of wire 10. According to the present invention, member 24 is  
15 preferably a lubricious polymer which has been properly loaded to have a radiopacity different from that of coil 26. It is this second level of radiopacity, preferably but not by way of limitation of a lower level than that of coil 26, which provides the improved method of steering the guide wire 10 through the lumens of the body by enabling the operator to have additional  
20 fluoroscopic information. In the preferred embodiment of Fig. 2, wire covering 24 comprises a Pebax polymer sleeve which has been loaded with a mixture that includes barium sulfate or other barium salts to provide the desired radiopacity. In the preferred embodiment the mixture comprises 60% to 70% barium sulfate. Reference is made to U.S. Patent No. 5,245,195  
25 regarding x-ray attenuation provided by a film of thermoplastic elastomer containing barium sulfate. It is also recognized that bismuth, tungsten, platinum and other high molecular weight metals may also be used for polymer loading 30% - 80% by weight.

Fig. 3 discloses another preferred embodiment of the guide wire of this  
30 invention which comprises a device similar to that of Fig. 2 except that covering member 24 of Fig. 2 has been replaced with a series of wire covering members 31, 33 and 35. Each of members 31, 33 and 35 is made of a polymer loaded to have a radiopacity different from one another and different from the radiopacity of coil 26. This plurality of radiopacity signals seen on a  
35 fluoroscope will provide still further information to the operator of the

placement of guide wire 10, thus enhancing the opportunity for more precise placement.

5 It is recognized that the loading of the polymer for radiopacity can also be done using a mixture of several high molecular weight metals and metal salts. It has been found that doing so creates greater radiopacity than could be achieved using a single component loading of equal amount. One preferred embodiment is a blend of barium sulfate, bismuth oxychloride and tungsten. The resulting blend can then be loaded into the polymer 20-80% by weight to achieve the desired radiopacity.

10 Having thus described the preferred embodiments of the present invention, those of skill in the art will readily appreciate the other useful embodiments within the scope of the attached claims.

## WHAT IS CLAIMED IS:

1. In a guide wire apparatus having a length of flexible wire with proximal and distal ends, a tip at the distal end of the guide wire, a first wire covering adjacent the tip and having a first radiopacity and further wire coverings including at least a second wire covering placed intermediate the first wire covering and the proximal end of the guide wire, the improvement comprising:
  - a) the second wire covering including a polymer sleeve having a load mixture of a radiopaque metal, the second wire covering having a second radiopacity; and
  - b) the second radiopacity being unequal to the first radiopacity.
2. The improved apparatus of claim 1 in which the second radiopacity is less than the first radiopacity.
3. The improved apparatus of claim 1 in which the second radiopacity is greater than the first radiopacity.
4. The improved apparatus of claim 1 in which the further wire coverings each have a radiopacity different from the first radiopacity.
5. The improved apparatus of claim 4 in which the radiopacity of each of the further wire coverings differs from every other wire covering radiopacity.
6. The apparatus of claims 1, 2 or 3 in which the polymer sleeve of the second wire covering has a load mixture of a radiopaque metal selected from the group consisting of bismuth, tungsten, platinum or barium sulfate.
7. The apparatus of claim 6 in which the load mixture is in the range of 60-70%.
8. The apparatus of claims 1, 4 or 5 in which the further wire coverings comprise polymer sleeves mounted to the guide wire and made of a material including a load of a mixture of a radiopaque metal.

9. The apparatus of claim 8 in which the load mixture is in the range of 60-70%.

10. The improved method of fluoroscopic placement of a catheter guide wire comprising the steps of:

- a) mounting a first wire covering adjacent a distal end of the guide wire;
- b) mounting at least a second wire covering intermediate the first covering and a proximal end of the guide wire, the second wire covering including a polymer sleeve having a load mixture of a radiopaque metal;
- c) providing the first wire covering with a first radiopacity; and
- d) providing the second wire covering with a second radiopacity different than the first radiopacity.

11. The improved method of fluoroscopic placement of a catheter guide wire comprising the steps of:

- a) mounting a first wire covering adjacent a distal end of the guide wire;
- b) mounting a plurality of further wire coverings intermediate the first covering and a proximal end of the guide wire, each further wire covering including a polymer sleeve having a load mixture of a radiopaque metal;
- c) providing the first wire covering with a first radiopacity;
- d) providing each of the further wire coverings with a different radiopacity; and
- e) making each of the different radiopacities different than the first radiopacity.

12. Catheter guide wire apparatus comprising:

- a) a length of flexible wire having proximal and distal ends;
- b) a tip connected to the distal end of the wire;
- c) a flexible coil mounted around the wire adjacent to the tip and extending proximally therefrom;
- d) a first polymer sleeve mounted around the wire adjacent to the coil and extending proximally therefrom;





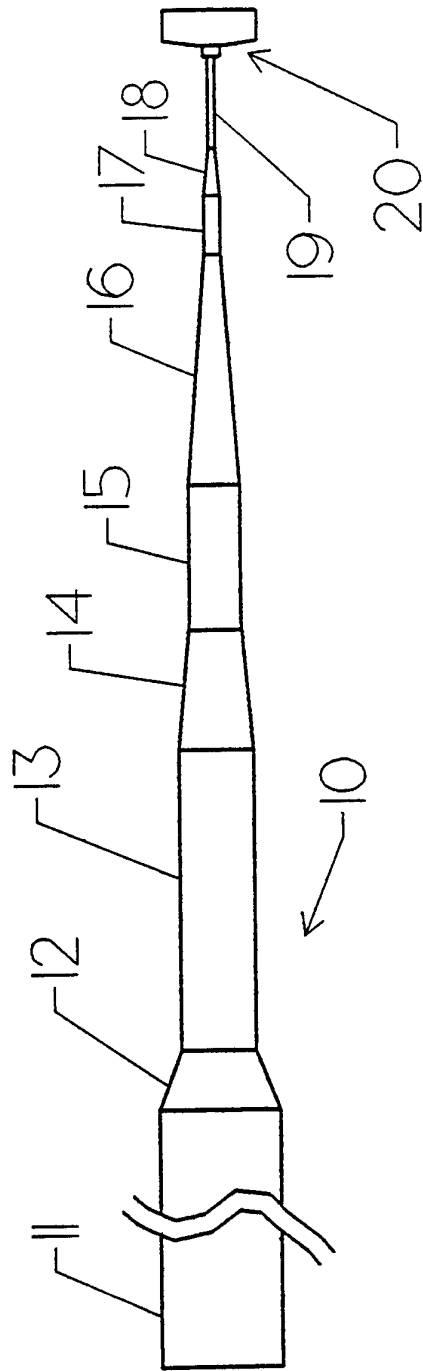

Fig. 1

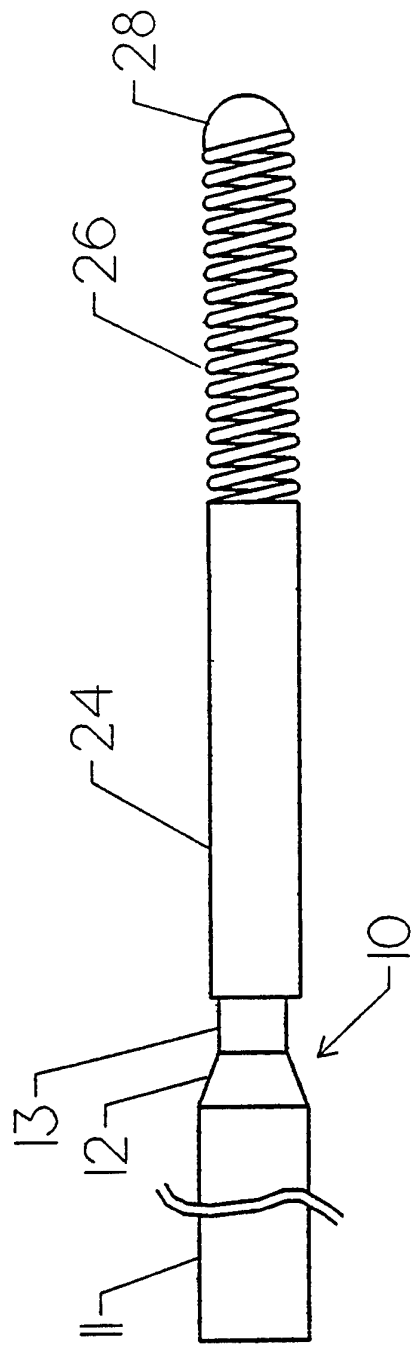

Fig. 2

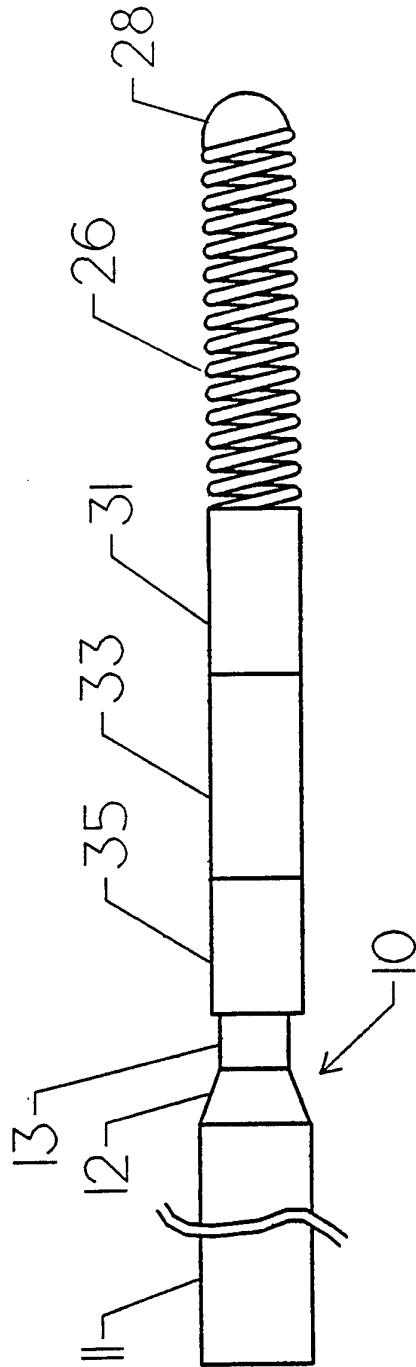

Fig. 3

# INTERNATIONAL SEARCH REPORT

Intern al Application No  
PCT/US 95/06226

A. CLASSIFICATION OF SUBJECT MATTER  
IPC 6 A61M25/01

According to International Patent Classification (IPC) or to both national classification and IPC

B. FIELDS SEARCHED

Minimum documentation searched (classification system followed by classification symbols)  
IPC 6 A61M

Documentation searched other than minimum documentation to the extent that such documents are included in the fields searched

Electronic data base consulted during the international search (name of data base and, where practical, search terms used)

C. DOCUMENTS CONSIDERED TO BE RELEVANT

Category *	Citation of document, with indication, where appropriate, of the relevant passages	Relevant to claim No.
A	US-A-5 259 393 (CORSO) 9 November 1993 see column 3, line 10 - column 4, line 14; figure 2 ---	1-4, 10-12
A	US-A-5 144 959 (GAMBALE) 8 September 1992 see abstract; figures 1-4 ---	1-4, 10-12
A	EP-A-0 597 195 (THE SPECTRANETICS) 18 May 1994 see abstract; figure 6 ---	1-4, 10-12
A	US-A-5 267 574 (VIERA) 7 December 1993 see column 3, line 23 - column 4, line 37; figure 2 ---	1,10-12
	-/--	

Further documents are listed in the continuation of box C.

Patent family members are listed in annex.

\* Special categories of cited documents :

- "A" document defining the general state of the art which is not considered to be of particular relevance
- "E" earlier document but published on or after the international filing date
- "L" document which may throw doubts on priority claim(s) or which is cited to establish the publication date of another citation or other special reason (as specified)
- "O" document referring to an oral disclosure, use, exhibition or other means
- "P" document published prior to the international filing date but later than the priority date claimed

- "T" later document published after the international filing date or priority date and not in conflict with the application but cited to understand the principle or theory underlying the invention
- "X" document of particular relevance; the claimed invention cannot be considered novel or cannot be considered to involve an inventive step when the document is taken alone
- "Y" document of particular relevance; the claimed invention cannot be considered to involve an inventive step when the document is combined with one or more other such documents, such combination being obvious to a person skilled in the art.
- "&" document member of the same patent family

Date of the actual completion of the international search

28 July 1995

Date of mailing of the international search report

25. 09. 95

Name and mailing address of the ISA  
European Patent Office, P.B. 5818 Patentlaan 2  
NL - 2280 HV Rijswijk  
Tel. ( + 31-70) 340-2040, Tx. 31 651 epo nl,  
Fax: ( + 31-70) 340-3016

Authorized officer

Kousouretas, I

# INTERNATIONAL SEARCH REPORT

International Application No  
PCT/US 95/06226

## C.(Continuation) DOCUMENTS CONSIDERED TO BE RELEVANT

Category <sup>o</sup>	Citation of document, with indication, where appropriate, of the relevant passages	Relevant to claim No.
P,A	US-A-5 353 808 (VIERA) 11 October 1994  see the whole document -----	1-4, 10-12

# INTERNATIONAL SEARCH REPORT

Information on patent family members

International Application No  
PCT/US 95/06226

Patent document cited in search report	Publication date	Patent family member(s)	Publication date
US-A-5259393	09-11-93	NONE	
US-A-5144959	08-09-92	JP-A- 3133463	06-06-91
EP-A-597195	18-05-94	CA-A- 2104239 JP-A- 6197910	19-02-94 19-07-94
US-A-5267574	07-12-93	NONE	
US-A-5353808	11-10-94	NONE	