

W. F. WATERS.

Improvement in Corn-Shellers.

No. 130,777.

Patented Aug. 20, 1872.

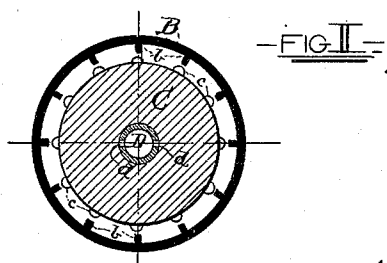
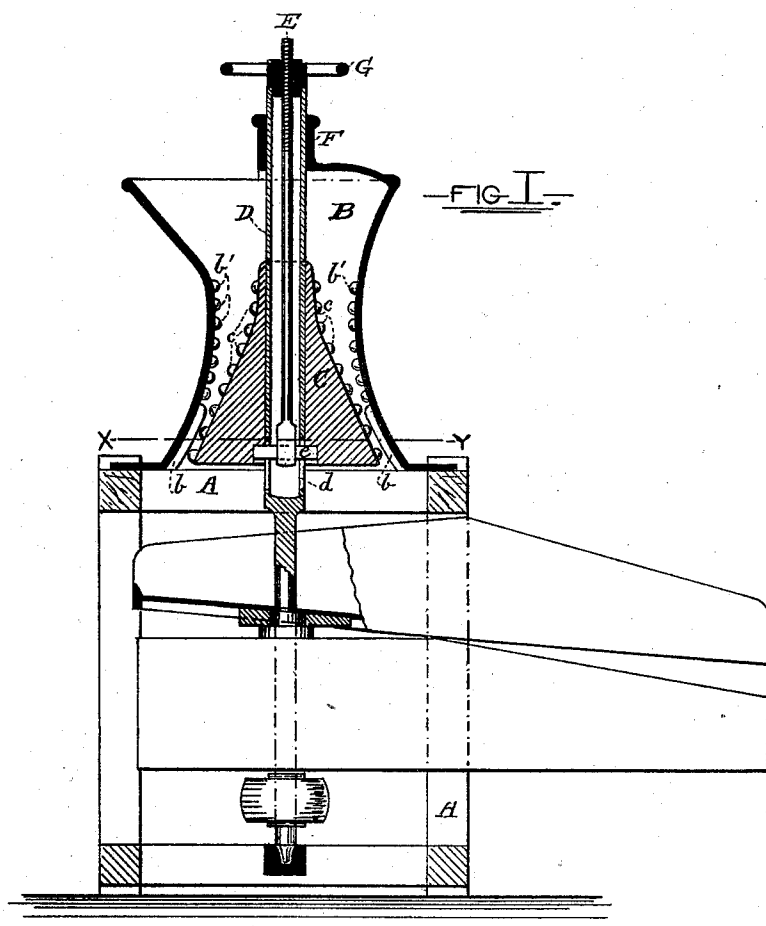

WITNESSES:

Geo. A. Howard
French F. No 14

INVENTOR:

Wilbur F. Waters
By his Attorney
J. H. Whippleman

UNITED STATES PATENT OFFICE.

WILBUR F. WATERS, OF DUNKIRK, NEW YORK.

IMPROVEMENT IN CORN-SHELLERS.

Specification forming part of Letters Patent No. 130,777, dated August 20, 1872.

To all whom it may concern:

Be it known that I, WILBUR F. WATERS, of Dunkirk, in the county of Chautauqua and State of New York, have invented certain Improvements in Corn-Shellers, of which the following is a specification; and I do hereby declare that the same is a full, clear, and exact description of my said invention, reference being had to the accompanying drawing and to the letters of reference marked thereon.

My invention relates to an adjusting device to be applied to the operating parts of a corn-sheller, by which it may be adapted to the size of the corn to be shelled. These operating or grinding parts consist of a conical cylinder and an interior cone, the working surface of the cylinder being provided with ribs and hemispherical studs, and that of the interior cone with similar studs. The cone is centered upon a tubular shaft, adapted by the use of a slot therein, and a feather fitted to the cone to slide within the cone, by which arrangement of parts it is made adjustable with reference to the interior of the cylinder. Passing through the tubular shaft, and connecting with the feather which slides within the slot in the tubular shaft, is a rod, threaded at its upper end and having thereupon a regulating band-wheel, used in the adjustment of the operating parts.

In the further description of my invention which follows, due reference must be had to the accompanying drawing, in which—

Figure 1 is a sectional elevation of my invention. Fig. 2 is a transverse section upon line X Y through the cylinder, cone, and tubular shaft.

Similar letters of reference indicate similar parts of the invention in both figures.

A is the frame of the machine. B is the conical cylinder, and C the interior cone. The ribs upon the interior surface of the cylinder are shown by *b*, and the hemispherical studs by *b'*. Like studs upon the exterior of the cone are shown by *c*. D is the tubular shaft upon which the cone is centered. A slot within the shaft is represented by *d*. Within the shaft D is a rod, E, having a feather, *e*, passing through it at its lower end. The feather slides within the slot *d* and is inserted

or fitted within the body of the cone. By this means the cone is secured to the rod E and also to the shaft D, revolving with them, at the same time being adapted to slide upon the shaft D. This shaft is reduced in diameter below the cone, which part is used with an eccentric and other appliances in the movement of the shaking screen beneath, and has upon it the driving pulley, ultimately resting in a step or bearing.

I give no detailed description of the parts below the top of the frame, they being such as are in common use for cleaning grain, screening, and other purposes. Their construction and operation, and their relation to the parts of my invention placed above them, can be seen at a glance by referring to the figure.

The upper part of the tubular shaft D passes through the saddle F. Upon the upper part of the rod E is the band-wheel G, the lower part of the hub of which fits within the tubular shaft. By lowering the wheel upon the rod E, by the bearing of the hub against the top of the tubular shaft, the cone sliding thereupon is elevated or brought more closely to the surface of the conical cylinder. By reversing the wheel the cone is lowered. The machine is thus adapted to the size of the corn to be shelled.

Having thus described my invention, what I claim as new, and wish to secure by Letters Patent, is—

1. In a corn-sheller, an adjusting device, consisting of the tubular shaft D with the slot *d*, inclosing the rod E, having the feather *e* and wheel G, arranged relatively and substantially as herein set forth.

2. In combination with the above-named adjusting device, the studded interior cone C and the studded and ribbed conical cylinder B and saddle F, arranged substantially as and for the purposes specified.

In testimony whereof I have hereunto signed my name.

WILBUR F. WATERS.

Witnesses:

JAMES SHEWARD,
DANIEL BEAN.