



(51) International Patent Classification:

*B65B 51/14* (2006.01)    *B29C 65/08* (2006.01)  
*B29C 65/02* (2006.01)    *B65B 51/22* (2006.01)  
*B29C 65/30* (2006.01)    *B65B 51/30* (2006.01)

(21) International Application Number:

PCT/EP2012/001877

(22) International Filing Date:

2 May 2012 (02.05.2012)

(25) Filing Language:

English

(26) Publication Language:

English

(30) Priority Data:

11003838.7    10 May 2011 (10.05.2011)    EP  
11003879.1    11 May 2011 (11.05.2011)    EP

(71) Applicant (for all designated States except US): **CFS WEERT B. V.** [NL/NL]; De Fuus No. 8, NL-6006 RV Weert (NL).

(72) Inventors; and

(75) Inventors/Applicants (for US only): **VAN RENS, Joseph, Johan, Maria** [NL/NL]; Windmolen 28, NL-6003 BK Weert (NL). **BAUMEISTER, Bruno, Gerfried** [DE/DE]; Heussstrasse 34, 52078 Aachen (DE). **HOUBEN, Eric,**

**Joseph, Elizabeth** [NL/NL]; Gerst 17, NL-5988 JS Helden (NL).

(74) Agents: **WOLFF, Felix** et al.; Kutzenberger & Wolff, Theodor-Heuss-Ring 23, 50668 Köln (DE).

(81) Designated States (unless otherwise indicated, for every kind of national protection available): AE, AG, AL, AM, AO, AT, AU, AZ, BA, BB, BG, BH, BR, BW, BY, BZ, CA, CH, CL, CN, CO, CR, CU, CZ, DE, DK, DM, DO, DZ, EC, EE, EG, ES, FI, GB, GD, GE, GH, GM, GT, HN, HR, HU, ID, IL, IN, IS, JP, KE, KG, KM, KN, KP, KR, KZ, LA, LC, LK, LR, LS, LT, LU, LY, MA, MD, ME, MG, MK, MN, MW, MX, MY, MZ, NA, NG, NI, NO, NZ, OM, PE, PG, PH, PL, PT, QA, RO, RS, RU, RW, SC, SD, SE, SG, SK, SL, SM, ST, SV, SY, TH, TJ, TM, TN, TR, TT, TZ, UA, UG, US, UZ, VC, VN, ZA, ZM, ZW.

(84) Designated States (unless otherwise indicated, for every kind of regional protection available): ARIPO (BW, GH, GM, KE, LR, LS, MW, MZ, NA, RW, SD, SL, SZ, TZ, UG, ZM, ZW), Eurasian (AM, AZ, BY, KG, KZ, RU, TJ, TM), European (AL, AT, BE, BG, CH, CY, CZ, DE, DK, EE, ES, FI, FR, GB, GR, HR, HU, IE, IS, IT, LT, LU, LV, MC, MK, MT, NL, NO, PL, PT, RO, RS, SE, SI, SK, SM, TR), OAPI (BF, BJ, CF, CG, CI, CM, GA, GN, GQ, GW, ML, MR, NE, SN, TD, TG).

[Continued on next page]

(54) Title: SEALING SYSTEM FOR A PACKAGING MACHINE

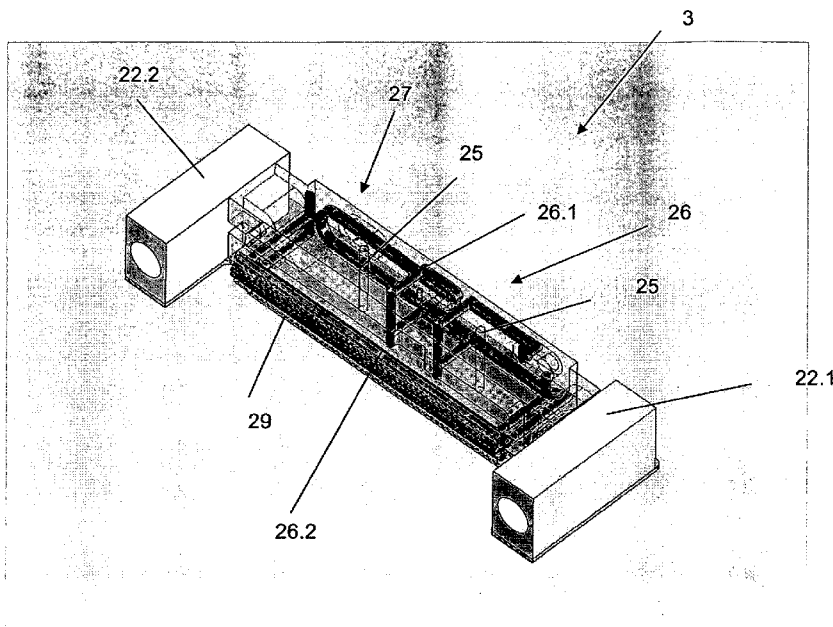

(57) Abstract: The following invention relates to a packaging machine with a sealing system comprising a front jaw and a rear jaw which reciprocate between an open-and a sealing-position, respectively, whereas a front jaw comprises two guide shafts which are supported in a frame.

Fig. 9

WO 2012/152403 A2

**Published:**

- *without international search report and to be republished upon receipt of that report (Rule 48.2(g))*

## Sealing system for a packaging machine

The present invention relates to a packaging machine with a sealing system comprising a front jaw and a rear jaw which reciprocate between an open- and a sealing-position, respectively, whereas the front jaw comprises two guide shafts which are supported in a frame.

Such a packaging machine is known from the state of the art and is for example a so called vertical flow wrapper in which a film is formed into a tube and is provided with a longitudinal seal. This tube is filled with the packaging item and a cross seal is provided at the lower and the upper end of the package. Subsequently, the package is separated from the film tube. The cross seal is applied by a sealing system which comprises a front jaw and a rear jaw which reciprocate between an open and a sealing position. The sealing system of these packaging machine is, however, rather complicated.

It was therefore the objective of the present invention to provide a packaging machine which does not comprise the deficiencies according to the state of the art.

The problem is attained with a packaging machine with a sealing system, comprising a front jaw and a rear jaw, which reciprocates between an open- and a sealing-position, respectively, whereas the front jaw comprises two guide shafts which are supported in a frame and whereas the rear jaw is supported on the guide shafts of the front jaw.

The disclosure made regarding this embodiment of the present invention also applies to the other embodiments and vice versa.

The present invention relates to a packaging machine, which packages a packaging item into individual packages. Preferably this packaging machine is a so called vertical flow wrapper, which forms a plain film into a tube, provides a longitudinal seal to the film tube, fills the film tube with a packaging item and provides a cross seal at the top and at the bottom of each package in order to close the package hermetically. Subsequently or simultaneously, the package is separated from the film tube. In order to apply the cross seal to the package, the inventive packaging machine comprises a sealing system. This sealing system has a front jaw and a rear jaw, which reciprocate between an open- and a sealing position. In the sealing position, the two jaws interact and apply heat and/or pressure to the film tube in order to apply the cross-seal. In the open position, the two jaws are removed from the film tube. The front jaw comprises two guide shafts, which are supported in a frame of the sealing system

and which guide the linear movement of the front jaw from its open to its sealing position and vice versa. According to the present invention, the guide shafts of the front jaw are also utilized to support/guide the rear jaw during its linear movement from the open- to the sealing-position and vice versa. This assures, that there is no offset between the front and the rear jaw and that the system is very stiff.

According to another or a preferred embodiment of the present invention, each guide shaft of the front jaw comprises two bearings, respectively. According to this embodiment of the present invention, all these four bearings are situated in a frame which is made from a single piece. This reduces manufacturing tolerances, simplifies the construction and provides optimal stiffness.

The disclosure made regarding this embodiment of the present invention also applies to the other embodiments and vice versa.

According to a preferred embodiment of the present invention, one bearing of each guide shaft of the front jaw is located between the front jaw and the rear jaw. This preferred embodiment of the present invention gives the sealing system maximum stability in the sealing position, since, during sealing, the frame, the front jaw and the rear jaw are very close together.

According to another or a preferred embodiment of the present invention, the front jaw and the rear jaw are connected to a beam, respectively. Both these beams are, according to this embodiment of the present invention, supported at the frame by linear guiding means. This avoids, that the guide shaft of the front jaw are subjected to shear forces.

According to another or a preferred embodiment of the present invention, the motor drives the jaws and provides the pressure needed for the sealing with ultrasonic sound. There are no other means needed to position the jaws and/or to provide the necessary pressure during the ultrasonic sealing.

According to a preferred embodiment of the present invention, the bearings of the inventive packaging machine are free from play. Preferably, the play between the bearing and the bared part is less than 20, preferably 10 micrometers.

Preferably, the jaws are driven by a servo motor.

According to another preferred embodiment of the present invention, the frame of the sealing system is made from two segments, which are connected by two side plates.

Preferably, the connection between the two segments and/or the connection between the side plates and the segments comprises dowel pins, in order to reduce manufacturing tolerances.

Preferably, at least one sealing jaw comprises a sonotrode for sealing of the film material with ultrasonic sound.

According to a preferred embodiment of the present invention, each jaw comprises two connections with shaft, respectively, whereas one connection of each jaw is preferably an adjustable connection and one connection of each jaw is preferably a fixed connection. This adjustment allows the exact positioning of the jaws relative to each other, particularly the parallel positioning of the jaws in one or two planes. Additionally or exclusively, the jaws can be adjusted relative to the shaft at a certain temperature, respectively. Preferably, the connection between the front jaw and the shaft comprises an adjustable bush in a chamber in the front jaw. Preferably the connection between the rear jaw and the shaft is an adjustable block. The jaws will be assembled and adjusted at a certain temperature.

Preferably, the sealing system comprises a heating- and/or cooling-means and more preferably a temperature sensor. The sealing system can preferably only be started and/or operated in case the temperature of the sealing system, particularly the temperature of one or both jaw(s) is/are in a range of the temperature at which it has been adjusted. If the temperature is out of this range, one or both jaws will either be cooled or heated. Preferably the rear jaw comprises an anvil which is heated to adjust the temperature.

Preferably, the sealing system comprises a film sensor. The sealing system can only be operated when the film sensor detects the presence of a film.

Another subject matter of the present invention is a sealing-jaw of a packaging machine that comprises heating- and/or cooling means.

The disclosure made regarding this embodiment of the present invention also applies to the other embodiments and vice versa.

The heating and/or cooling means are utilized to heat or cool the sealing jaw to a certain temperature and/or to maintain the sealing jaw at a certain temperature. Preferably, the heating means is an electrical heating means, for example one or more heating cartridge(s). Preferably, the heating- and/or the cooling means are designed such that anvil of the jaw and the bearings of the sealing jaw comprises an at least essentially uniform temperature, respectively. This assures that there is no or only minimal distortion in the anvil, the bearings and/or the jaw, so that so that the front jaw and the rear jaw are perfectly parallel, which is particularly essential for the sealing of a thin film. The cooling means is preferably a tube system, preferably a tube circuit, in which a liquid, preferably water flows and is preferably circulated and which, more preferably is provided within the anvil of the sealing jaw. The water flow can be also utilized for heating-purposes. Preferably, the tube system extends along the front- and along the rear side of the anvil. This also assures an, at least essentially, equal temperature of the anvil und thus no distortion. Preferably, a temperature sensor is provided at the anvil, in the vicinity of the anvil and/or in the liquid to measure the temperature of the anvil. Preferably, the temperature of the liquid that is passed through the anvil is 45 – 50 °C, more preferably 48 – 52 °C.

The heating means are preferably utilized to bring and/or maintain the rear jaw at a certain, more preferably a minimum, temperature.

Another subject matter of the present invention is a method to seal a packaging with two jaws, whereas at least one jaw, preferably the rear jaw, is tempered prior to sealing.

The disclosure made regarding this embodiment of the present invention also applies to the other embodiments and vice versa.

This embodiment of the present invention assures that the quality of the sealing of the film is acceptable even during the entire production period, even after start-up at the beginning of a shift. The temperature of the jaw, particularly the rear jaw and preferably, at least the anvil is heated until a certain temperature is reached. Only then, the inventive packaging machine starts its production. The heating is preferably executed by one or more electrical heating means, preferably heating cartridge(s).

Yet another subject matter of the present invention is a method to seal a packaging with a sonotrode, whereas the sealing period is adjusted based on the temperature of the sonotrode. According to the present invention, a package, made from a plastic film is formed,

filled with a packaging item and then hermetically closed by sealing the film. The sonotrode is utilized to seal a film with ultrasonic sound. The sonotrode provides the ultrasonic sound.

The disclosure made regarding this embodiment of the present invention also applies to the other embodiments and vice versa.

According to the present invention, the sealing time is adjusted based on the temperature of the sonotrode. Preferably, the sealing time is decreased with increasing temperature of the sonotrode. The sealing time is the time during which the two sealing jaws are pressed together.

Preferably, the inventive packaging machine and/or the inventive method is self adapting. For example, after a certain time period after the start of the packaging machine and/or after a certain amount seals have been applied to the film, a control system automatically reduces the sealing time. Alternatively, the temperature of the sonotrode is determined and based on this reading, the sealing time is automatically adjusted.

The inventions are now explained according to figures 1-9. These explanations do not limit the scope of protection. The explanation applies to all inventions, respectively.

Figure 1 shows the sealing system.

Figure 2 shows the bearing of the guide shaft.

Figure 3 shows the linear guiding means.

Figure 4 shows the connection between the frame and the side plates.

Figure 5 shows the bearings in the frame.

Figure 6 shows the sealing system.

Figure 7 shows the connection between the jaws 2, 3 and the guide shaft.

Figure 8 shows a film sensor.

Figure 9 shows the inventive sealing jaw

Figures 1 and 6 show the sealing system 1 of the inventive packaging machine. This sealing system 1 comprises a front jaw 2 and a rear jaw 3 which reciprocate between an open- and a sealing-position. The sealing position is depicted in figure 1 and the open position is depicted in figure 6. The front jaw 2 is connected to two guide shafts 4, which are supported in a frame 13 of the sealing system 1. At their rear end, the guide shafts 4 are connected to a beam 5. As can be particularly seen from figure 6, the rear jaw 3 comprises bearings 22, which support the rear jaw 3 at the guide shafts 4 of the front jaw 2. Each bearing 22 comprises preferably two segments, which are separated from each other so that a moment of a torque can be easily transferred from the rear jaw 3 to the guide shaft 4. Additionally, the rear jaw 3 is connected to two drive shafts 7, which comprise at their rear end a beam 6. Each beam 5, 6 is connected with one end of a crank 8, respectively. The other end of the cranks 8 are connected to a rotational drive 9, which is driven by a motor 17, preferably a servo motor. By turning the rotational drive clockwise, the front jaw 2 and the rear jaw 3 move from their open position to the sealing position. A counter clockwise rotation of the rotation drive 9 results in a movement of the jaws 2, 3 into their open position. In order to avoid, that the guide shaft 4 and/or the drive shaft 7 is subjected to a shear force, both beams 5, 6 comprise a bearing 18, respectively, each supported on a linear guiding means 19. As can be also seen from figure 6, two bearings 15 of the guide shaft 4 are located between the front shaft 2 and the rear shaft 3. This assures, that the bearing and the front and the rear jaw 2, 3 are in close proximity during sealing. As can be also seen from figure 6, each guide shaft 4 is supported by two bearings 15, 16, respectively, which are relatively far apart in order to increase the stiffness of the system. All four bearings 15, 16 are situated in a first segment 13.1 of frame 13, which is machined from a single piece of metal. The entire frame 13 is, in the present case, made from two segments 13.1, 13.2, which are connected to each other by two side plates 14. One segment, 13.1 comprises all four bearings 15, 16, the other segment 13.2 comprises the beam 5, 6 for the jaws 2, 3. In order to reduce manufacturing tolerances, the segment 13.1, 13.2 and all the side plates are connected to each other by dowel pins 20 which can be particularly seen from figure 4. All bearings 15, 16, 22 are preferably play free bearings, for example ball recirculating sleeve bearings. In the present case, the sealing of the film, particularly the cross-seal is provided by means of a ultrasonic sound. Therefore, the sealing system comprises a sonotrode 28, in the present case two sonotrodes 28, which are operated in parallel and which are both connected to the front jaw 2. Preferably, the position of both sonotrodes 28 relative to the front jaw 2 can be adjusted individually. Preferably, the frequency and/or the amplitude of each sonotrode can be set individually.

Reference is now made to figure 2. It can be clearly seen, that each shaft 4 is supported to the frame 13 by bearings 15, 16, which are separated from each other. All four bearings 15, 16 are supported in one segment 13.1 of frame 13, which is manufactured from a single piece of metal.

In figure 3, the linear guiding means 19 of the beams 5, 6 can be seen, each beam 5, 6 comprises a bearing 18, in the present case a play free bearing, which is supported on the linear guiding means 19. The cooperation of bearings 18 and the linear guiding means 19 avoid, that shear forces are introduced into shafts 4 or shafts 7. Preferably, the bearing is a ball recirculating sleeve bearing.

Figure 4 shows the connection between the segment 13.1 and side plates 14. The connection comprises dowel pins 10 and fastening means here screws 21. The dowel pins assure the exact positioning between the segment 13.1 and the side plate 14.

From figure 5, it can be seen, that all four bearings 15, 16 are situated in one segment 13.1 of frame 13.

According to figure 7, each jaw 2, 3 comprises two connections 22.1, 22.2, 23.1, 23.2 with the shafts 4, respectively, whereas one connection 22.1, 23.1 of each jaw 2, 3 is an adjustable connection and one connection 22.2, 23.2 of each jaw 2, 3 is preferably a fixed connection. This adjustment preferably allows the exact positioning of the jaws 2, 3 relative to each other, particularly the parallel positioning of the jaws 2, 3 relative to each other in one or more plane(s). Additionally or exclusively, the jaws 2, 3 can be adjusted relative to the shaft 4 at a certain temperature, respectively. Preferably, the connection between the front jaw and the shaft comprises an adjustable bush in a chamber in the front jaw. Preferably the connection between the rear jaw and the shaft is an adjustable block. The jaws will be assembled and adjusted at a certain temperature. Preferably, the sealing system comprises a heating- and/or cooling-means and more preferably a temperature sensor. The sealing system can preferably only be started and/or operated in case the temperature of the sealing system, particularly the temperature of one or both jaw(s) is in a range of the temperature at which it has been adjusted. If the temperature is out of this range, one or both jaws will either be cooled or heated or the system will be shut down. Preferably the rear jaw comprises an anvil which is heated to adjust the temperature.

In figure 8, the sealing system comprises a film sensor 24. The sealing system can only be operated when the film sensor 24 detects the presence of a film.

27/06/2012

Figure 9 shows the inventive rear sealing jaw 3, which comprises, in the present case, an anvil 27 and two bearings 22.1, 22.2, in the present case designed as bearing-blocks. In the present example, the sealing of the film is applied by ultrasonic sound, which is provided by a sonotrode, which is part of the front jaw 2. At its front side, the anvil comprises a sealing bar 29, which is in contact with the film, in order to apply the seal to the film, which, during sealing, is pressed between the sonotrode 28 and the sealing bar 29.

According to the present invention, the rear jaw 3, particularly its anvil 26 is heated and/or cooled, to bring and/or maintain the sealing jaw and/or the anvil at a certain temperature, whereas a uniform temperature, particularly over the entire anvil 26. A uniform temperature distribution over the anvil 26 assures that no or only little distortion of the anvil takes place, so that the sealing bar 29 is always parallel to the sonotrode. In the present case, the heating is carried out by two cartridges 25. The cartridges are particularly utilized to increase the temperature of the rear jaw after a longer production-break. Additionally or alternatively, the anvil comprises a tube system 26 in the anvil 27. Through the tube system, a liquid, preferably water, is passed to cool and/or heat the rear jaw. The tube system can be part of a closed loop comprising a heat-exchange-element to heat or cool the temperature of the liquid, if needed. As can be clearly seen, that the tube system extends along the front end 26.2 and along the rear end 26.1 of the anvil, in order to achieve a uniform temperature in the anvil. The person skilled in the art understands, that heat can be transferred from the anvil to the bearings in order to adjust, i.e. heat and/or cool, their temperature. Preferably the anvil and the bearings are at the same temperature.

Before the operation of the inventive packaging machine is started, for example at the beginning of morning shift, the rear jaw is preferably heated to its operation temperature. This is preferably done by the electrical heating elements 25. As soon as this temperature has been reached, the packaging machine starts packaging articles.

**List of reference signs:**

- 1 Sealing System
- 2 Front jaw
- 3 Rear jaw
- 4 Guide shaft, drive shaft
- 5 Beam for the front jaw
- 6 Beam for the rear jaw
- 7 Drive shaft rear jaw
- 8 Crank
- 9 Rotation means
- 10 Linear guide
- 11 Bearing for the vertical movement of the system
- 12 Bearing for the rear jaw
- 13 Frame
- 13.1 first segment of the frame
- 13.2 second segment of the frame
- 14 Side plate
- 15 Bearing for the guide shaft 4
- 16 Bearing for the guide shaft 4
- 17 Motor
- 18 Bearing
- 19 Linear guiding means
- 20 Dowel pin
- 21 Fastening means, screw
- 22 Bearing of the rear jaw
- 23 Connection between the front jaw and the guide shaft
- 24 Film sensor
- 25 heating cartridge
- 26 liquid circuit
- 27 anvil
- 28 sonotrode
- 29 sealing bar

**Claims:**

1. Packaging machine with a sealing system (1), comprising a front jaw (2) and a rear jaw (3), which reciprocate between an open- and a sealing-position, respectively, whereas the front jaw (2) comprises two guide shafts (4) which are supported in a frame (13), characterized in, that the rear jaw (3) is supported on the guide shafts (4) of the front jaw.
2. Packaging machine according to claim 1 or the preamble of claim 1, characterized in, that each guide shaft (4) comprises two bearings (15, 16), respectively and that all bearings (15, 16) are situated in a frame (13.1) which is made from one single piece.
3. Packaging machine according to one of the preceding claims, characterized in that a bearing (15) of the guide shaft (4) is located between the front jaw (2) and the rear jaw (3).
4. Packaging machine according to one of the preceding claims or the preamble of claim 1, characterized in, that the front jaw (2) is coupled to a beam (5) and the rear jaw is connected to a beam (6) and that each beam (5, 6) is supported at the frame (13) by a linear guiding means (19) respectively.
5. Packaging machine according to one of the preceding claims or the preamble of claim 1, characterized in, that the motor (17) drives the jaws (2, 3) and provides the pressure needed for the sealing with ultrasonic sound.
6. Packaging machine according to one of the preceding claims, characterized in that the bearings (15, 16, 22) are free from play.
7. Packaging machine according to one of the preceding claims, characterized in that the jaws (2, 3) are driven by a servo motor.
8. Packaging machine according to one of the preceding claims, characterized in that the frame (13) is made from two pieces (13.1, 13.2) which are connected by two side plates (14).

9. Packaging machine according to claim 8, characterized in, that the parts (13.1, 13.2) of the frame (13) and/or the side plates (14) are connected by dowel pins (20).
10. Packaging machine according to one of the preceding claims, characterized in, that the sealing system is based on ultrasonic sound.
11. Packaging machine according to one of the preceding claims, characterized in, that each jaw (2, 3) comprises two connections (22, 23) with shaft (4), respectively, whereas one connection (22.1, 23.1) of each jaw (2, 3) is an adjustable connection and one connection (22.2, 23.2) of each jaw (2, 3) is a fixed connection.
12. Sealing-jaw (2, 3) of a packaging machine, characterized in, that it comprises heating- and/or cooling means (25, 26).
13. Sealing-jaw (2, 3) according to claim 12, characterized in, that it comprises an anvil and that the heating- and/or cooling means (25, 26) are distributed at the front- and at the rear part of the anvil.
14. Method to seal a packaging with two jaws (2, 3), characterized in, that at least one jaw is tempered prior to sealing.
15. Method to seal a packaging with a sonotrode, characterized in, that the sealing period is adjusted based on the temperature of the sonotrode.

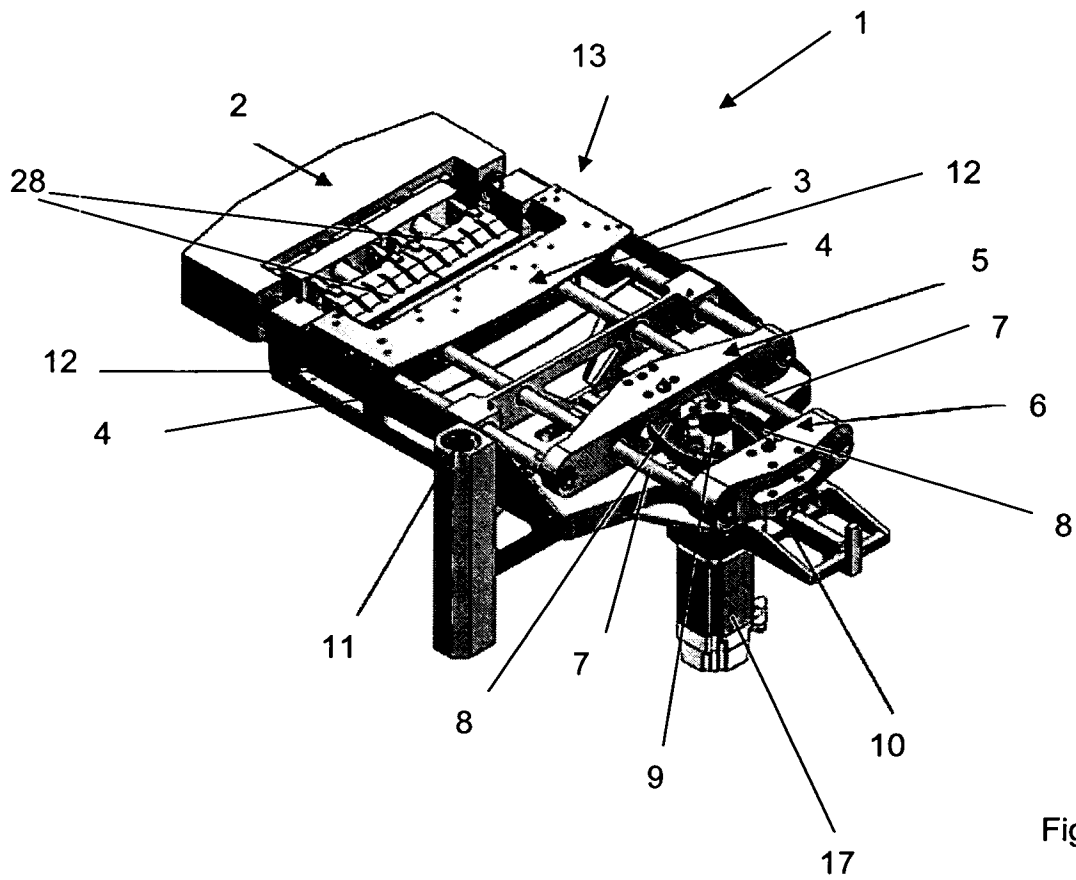

Fig. 1

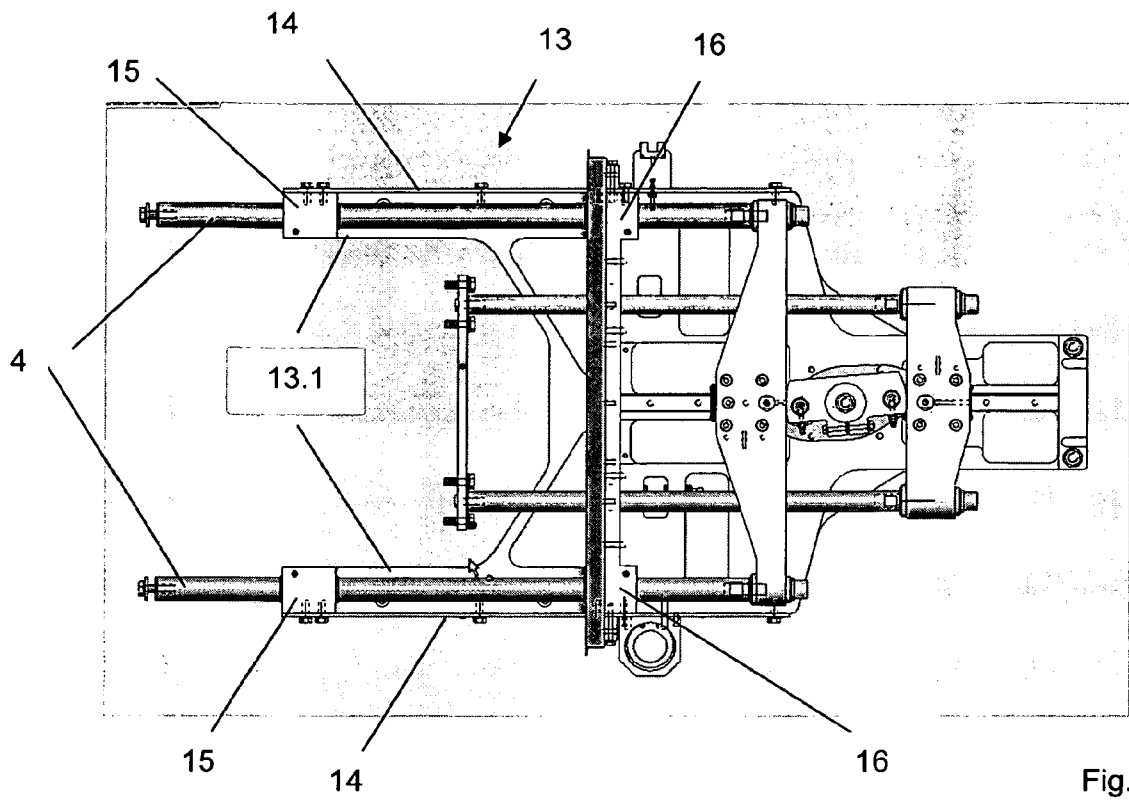

Fig. 2

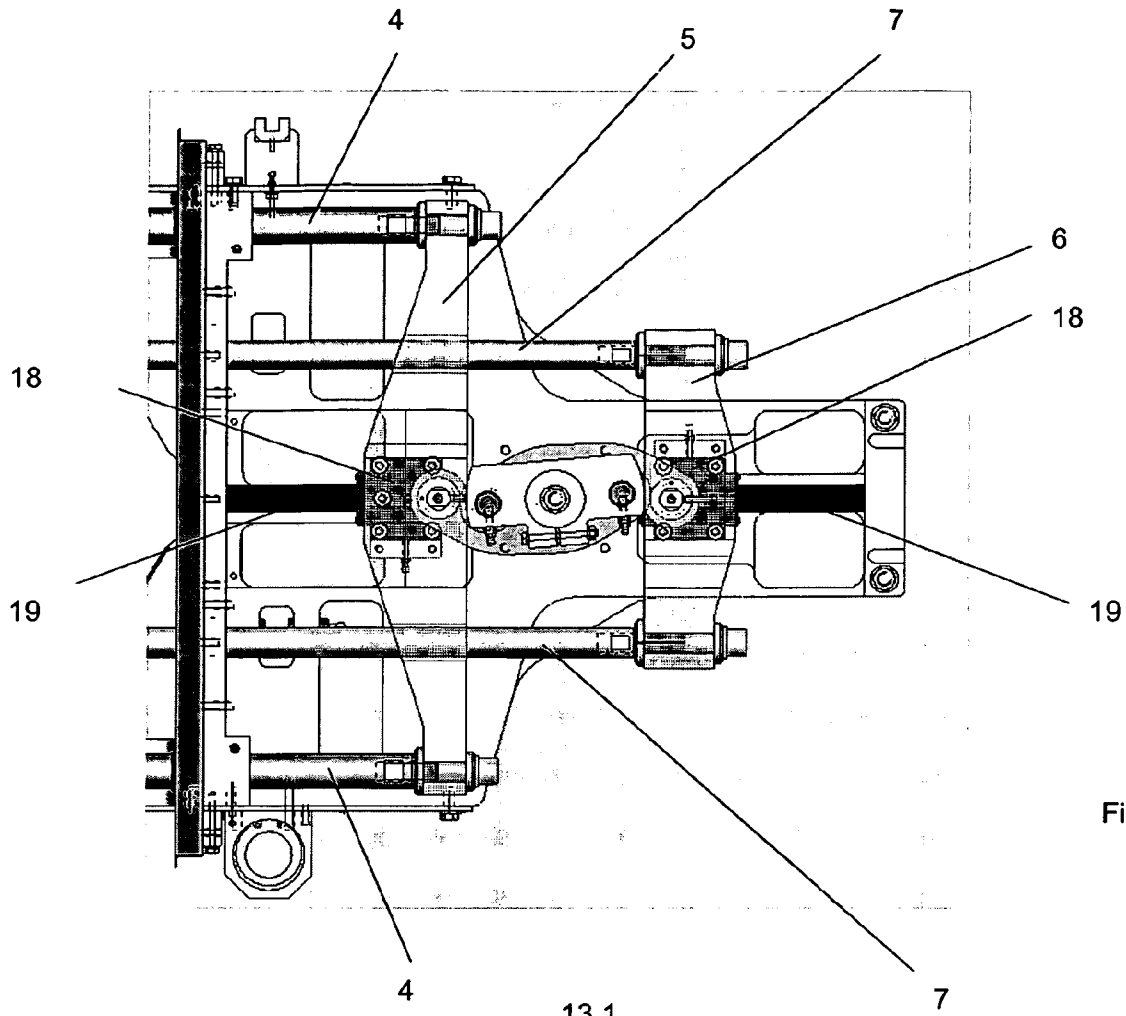

Fig. 3

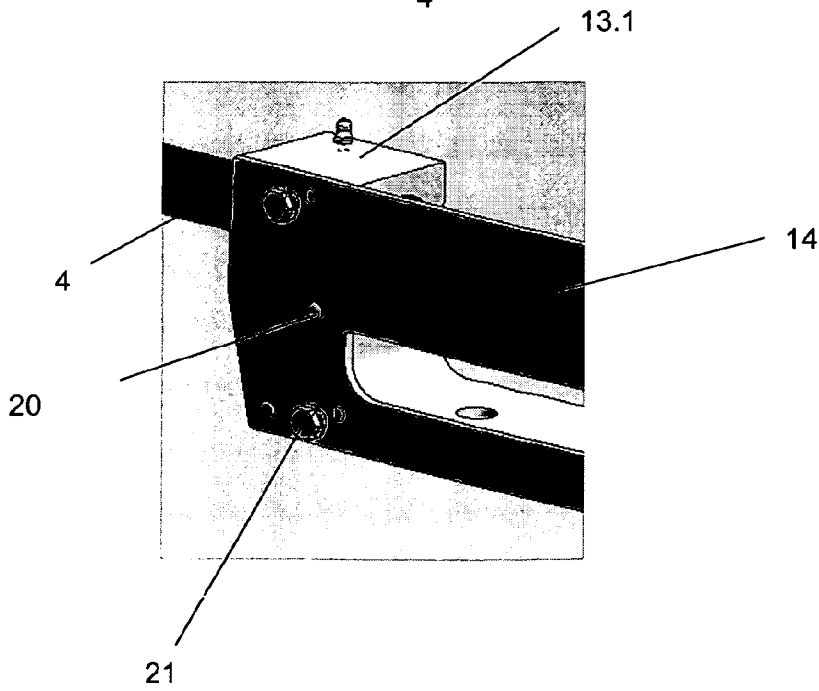

Fig. 4

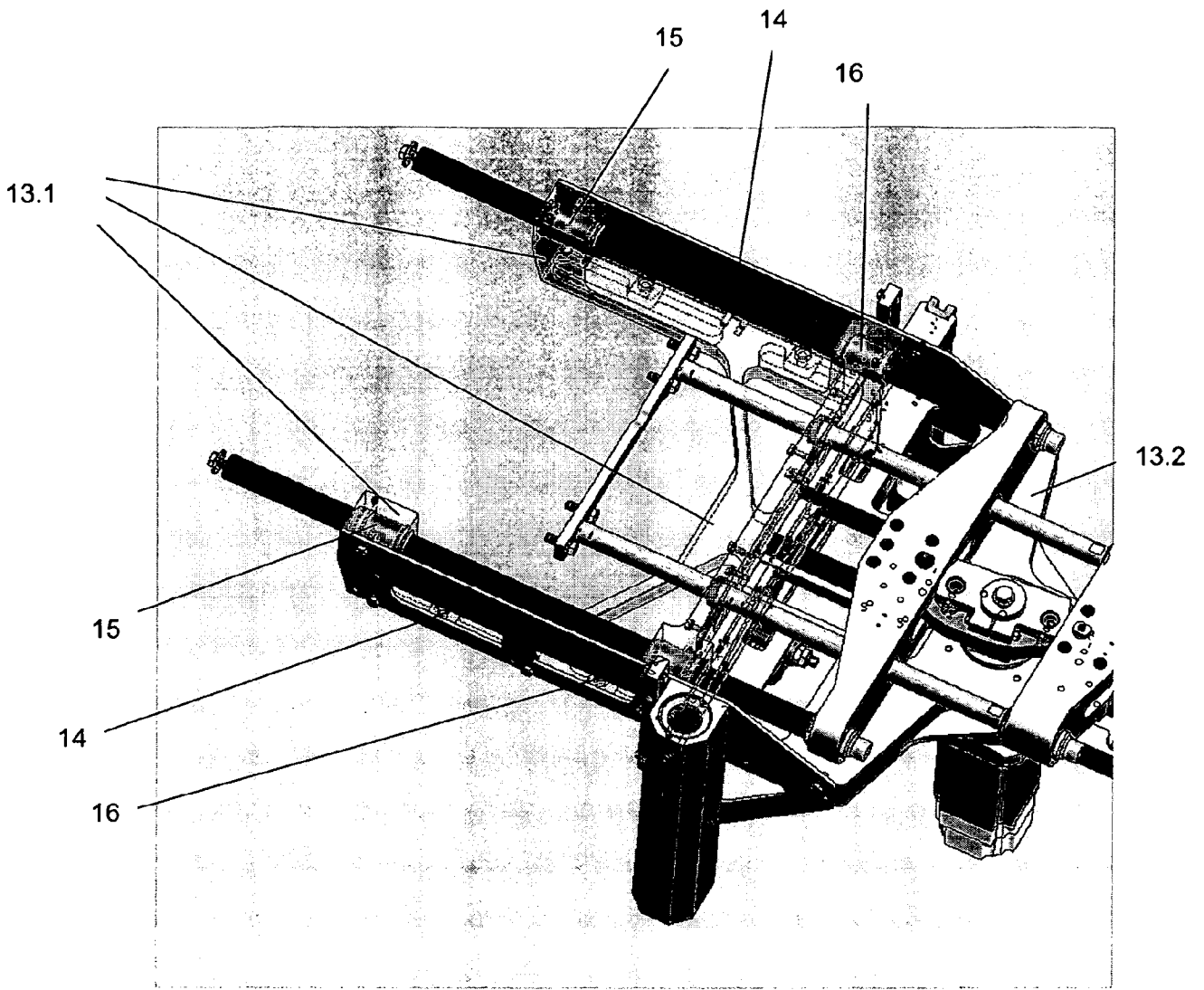

Fig. 5

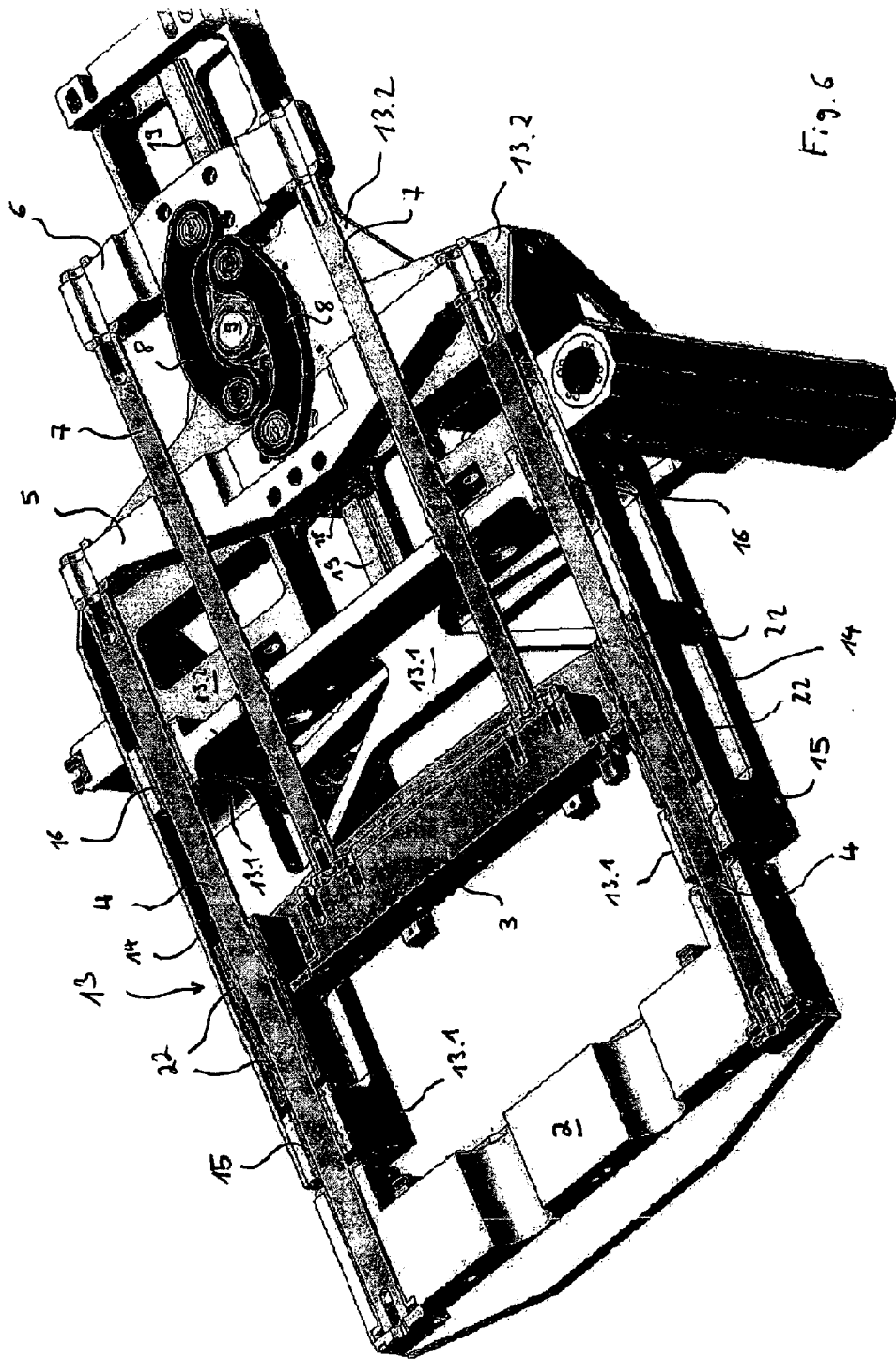

Fig. 6

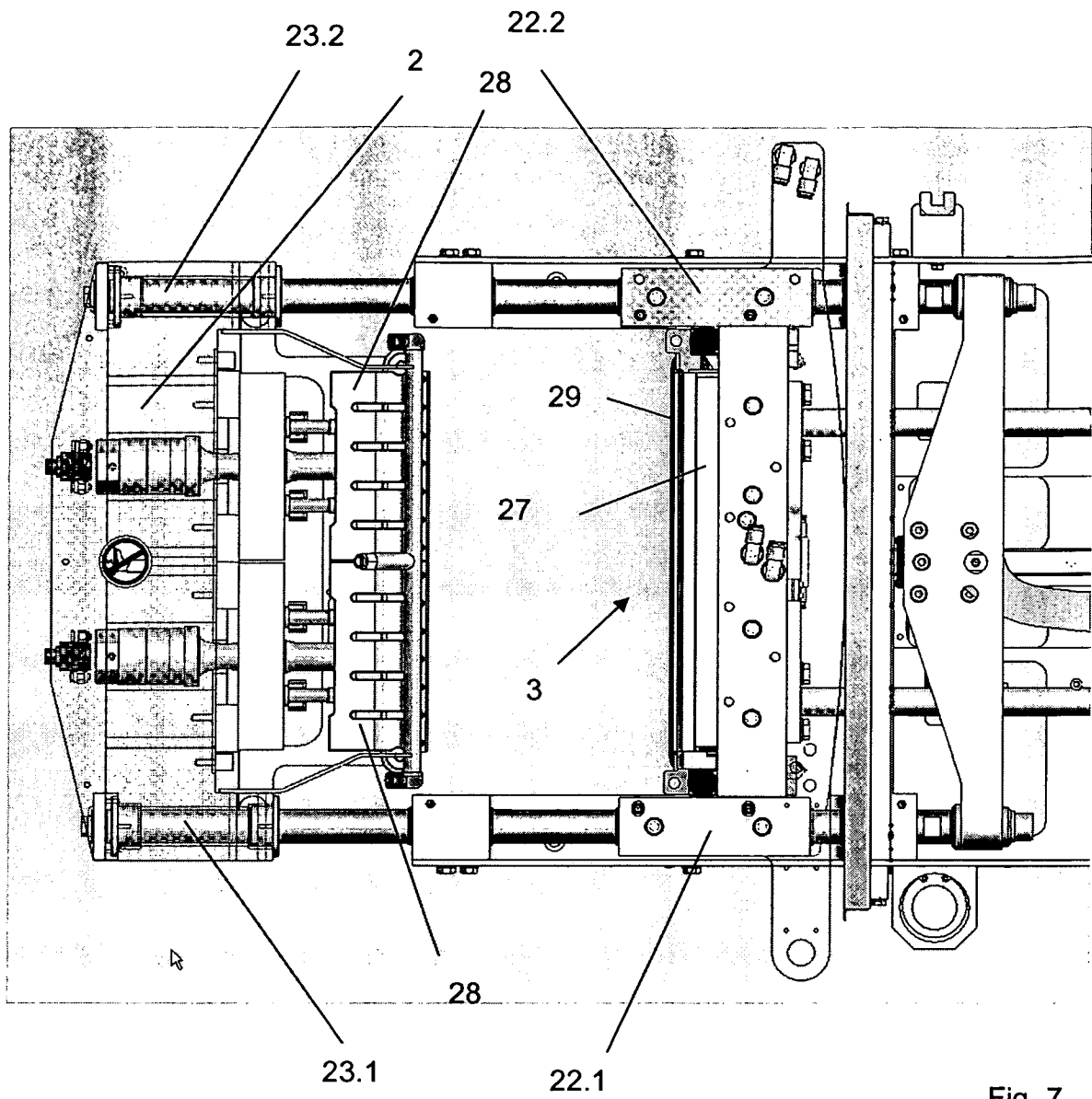
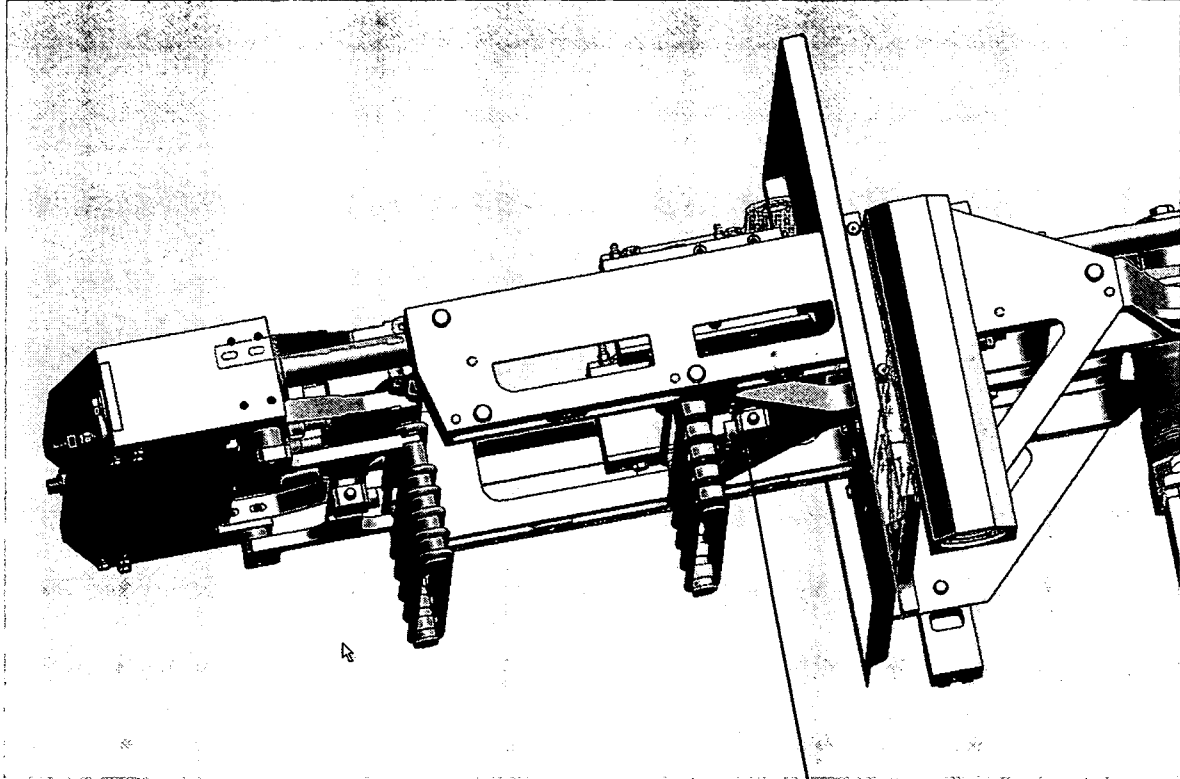

Fig. 7



24

Fig. 8

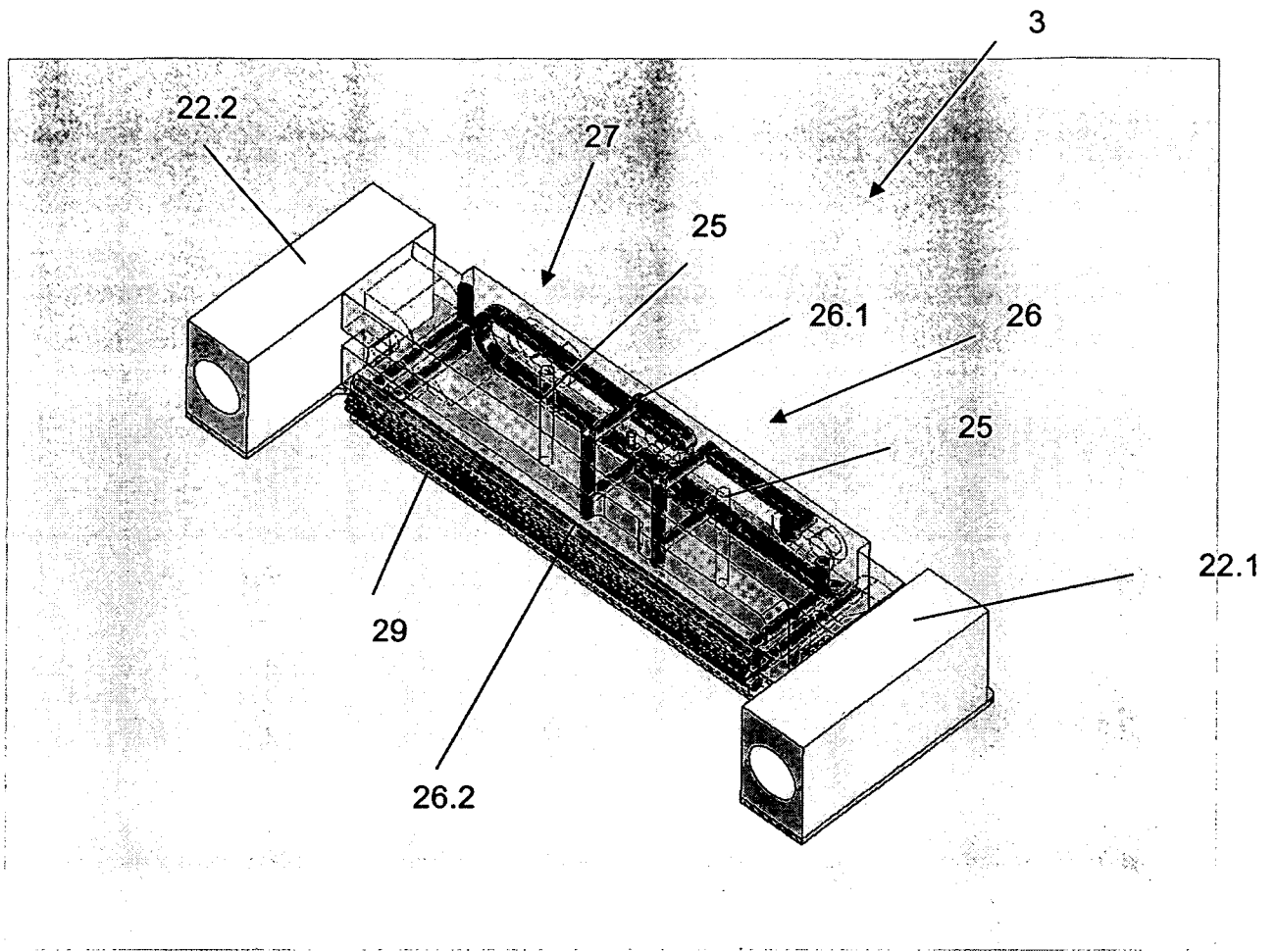

Fig. 9