

Sept. 16, 1969

J. G. B. LINDAU ET AL

3,467,433

DETACHABLE FURNITURE

Filed Sept. 19, 1967

2 Sheets-Sheet 1

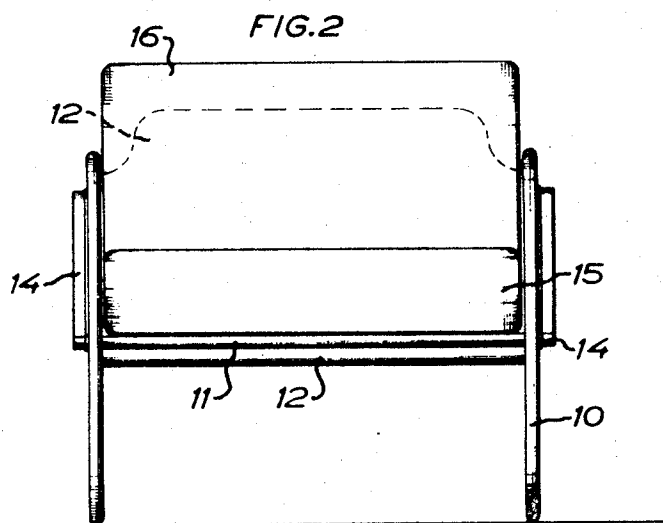
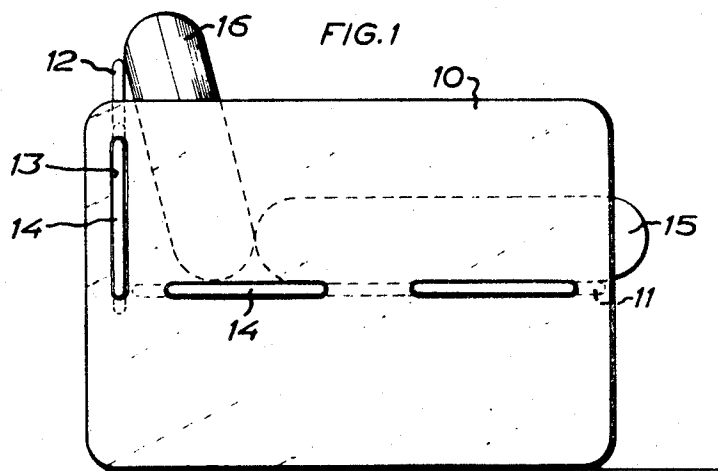

INVENTORS:

JOHN GUSTAF BÖRGE LINDAU &
BO KRISTOFFER LINDEKRANTZ

by

Brown, Schuyler & Beveridge
Attorneys

Sept. 16, 1969

J. G. B. LINDAU ET AL

3,467,433

DETACHABLE FURNITURE

Filed Sept. 19, 1967

2 Sheets-Sheet 2

FIG. 3

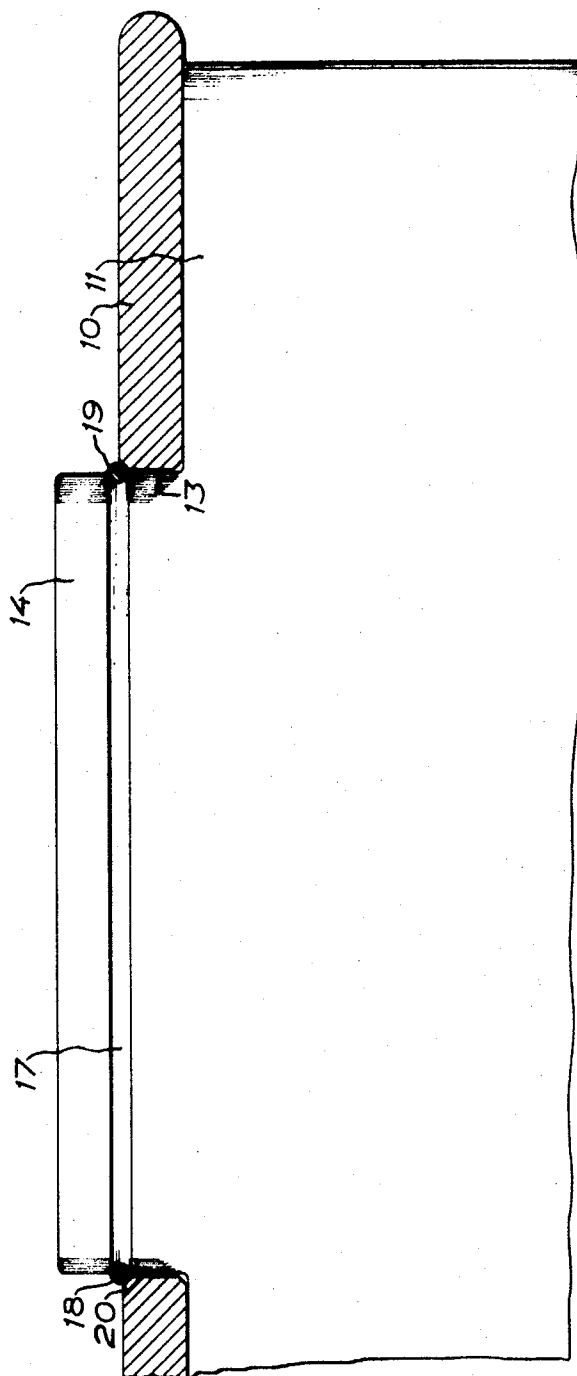

INVENTORS:
JOHN GUSTAF BÖRGE LINDAU &
BO KRISTOFFER LINDEKRANTZ

by
Browne, Schuyler & Beveridge
attorneys

1

2

3,467,433

DETACHABLE FURNITURE

John Gustaf Börge Lindau, Kopp. Molleg 8B, and Bo Kristoffer Lindekrantz, Lagervagen 35B, both of Halsinborg, Sweden

Filed Sept. 19, 1967, Ser. No. 668,879

Claims priority, application Sweden, Sept. 28, 1966, 13,090/66

Int. Cl. A47c 7/02, 7/00

U.S. Cl. 297-442

2 Claims

ABSTRACT OF THE DISCLOSURE

A piece of furniture the members of which are detachably connected together by pin and slot connections, the pins having such a length as to project from the slots and being provided with a ring of synthetic plastics mounted in a groove in the pin and preventing withdrawal of the pin from the slot.

This invention relates to detachable furniture consisting of sheets, plates, rods and like members which can be assembled to form furniture with the aid of slots in said members and pins preferably integral with said members, each of said pins having at one end an abutment, i.e. the wall or edge from which the pin projects.

Nowadays furniture must often be detachable for instance to permit moving it to another location in a room, or between different rooms or different apartments. There is a special need of this type of furniture in institutes and schools teaching the subject "interior decoration" in which the students now mostly carry around pieces of furniture and arrange them in different layouts. To improve the teaching of the subject "interior decoration" it would be valuable if the students instead could assemble the furniture in accordance with their own intentions, making suitable combinations of various sets and pieces of furniture. As furniture intended for such purposes may be expected to be subject to rough handling both upon assembly and use thereof, it is important that the assembly can be performed in an extremely simple way excluding possible errors, and after assembly the furniture should be capable of withstanding considerable stresses.

Furniture of this kind also is very suitable as nursery furniture since it gives children who often tire of their belongings the possibility of rapidly reconstructing their furniture, possibly with the aid of supplementing details of some kind.

The invention thus has for its object to provide means for simple assembling of furniture, said means also permitting rough handling of the furniture after assembly.

According to the invention this is realized in that the pin at a distance from the abutment has a transverse groove preferably extending all around the pin and intended to accommodate a ring of synthetic plastics to prevent unintentional withdrawal of the pin from the slot, that the groove is spaced such a distance from the abutment that when the member engages the abutment a portion of the groove will project into the slot, and that the peripheral edge of the slot is bevelled above the

groove portion projecting into the slot. By this arrangement it is practically impossible unintentionally to remove the pin from the slot because the force exerted at the removal due to the relative position between the groove and the bevel of the slot will tend to urge the ring of synthetic plastics into a firmer engagement with the groove. To permit removal of the pin for dismounting of the furniture there is provided in said bevel, according to a further characteristic feature of the invention, a recess through which a tool can be inserted so as to engage the rear face of the ring, whereby the ring can be withdrawn from the groove to release the pin.

The above features of the invention and the advantages gained thereby will become more fully apparent from the following specification in which reference is made to the accompanying drawings illustrating a preferred form of the invention.

In the drawings:

FIGURE 1 is a side view of an armchair assembled in accordance with the invention;

FIGURE 2 is a front view of the armchair;

FIGURE 3 is a view of a pin inserted in a slot.

The armchair illustrated in FIGURE 1 comprises two side frame members 10 which are interconnected by a seat member 11 and a back member 12, all of said members consisting of boards of plywood. To permit assembly of the armchair the side frame members have elongated slots 13 and the seat and back members have corresponding elongated pins 14 exactly fitting the slots and insertable therein for instance under wringing fit. The pins 14 are retained in the slots with the aid of means that will be described more in detail with reference to FIGURE 3. A cushion 15 is placed on the seat member 11, and a cushion 16 is placed in application against the back member 12 of the armchair.

The pins are anchored in the slots in the manner shown in FIGURE 3 in which one of the pins of the seat member is shown engaged in a slot in one of the side frame members. As will appear from the drawing, the pin has a groove 17 which extends transversely of the pin at such a distance from the edge of the seat member 11 that part of the groove 17 is accommodated in the slot 13 when the pin is inserted therein. Opposite the part of the groove 17 accommodated in the slot the edge of the slot 13 is bevelled as shown at 19. By placing, after insertion of the pin in the slot 13, a ring 18 of synthetic plastics in the groove 17 the seat member 11 is efficiently prevented from unintentionally getting loose from the side frame member 10 inasmuch as the bevel 19 tends to urge the ring of synthetic plastics into a firmer engagement with the groove 17, as will be clearly seen from FIGURE 3. As a matter of fact, the engagement of the ring of synthetic plastics with the groove is so firm that when it is desired to dismount the armchair the ring of synthetic plastics will have to be loosened with the aid of a special tool (not shown) inserted through a recess 20.

What we claim and desire to secure by Letters Patent is:

1. A piece of furniture including members forming the frame of the piece of furniture, said members being detachably connected together by pin and slot connections, the pins being of such a length as to project from

3

the slots and having in each of the projecting portions a transverse groove extending around each of said pins, a portion of said groove projecting into said slot, the peripheral edge of the slot adjacent the groove being bevelled, and a ring of synthetic plastic in said groove engaging the bevel of the peripheral edge of the slot and preventing withdrawal of the pin from the slot.

2. A piece of furniture as claimed in claim 1 and the bevelled peripheral edge of the slot having a recess to permit insertion of a tool for engaging the ring of synthetic plastics to allow removal thereof.

4

References Cited

UNITED STATES PATENTS

2,334,912	11/1943	Eide	297—442 X
2,720,253	10/1955	Turner et al.	297—442
3,001,824	9/1961	Wiener	297—458
3,281,185	10/1966	Albinson et al.	297—457 X

CASMIR A. NUNBERG, Primary Examiner

U.S. Cl. X.R.

297—445