

H. B. PANCOAST & F. I. MAULE.
Sectional Steam-Boilers.

No. 136,453.

Patented March 4, 1873.

Fig. 1

12

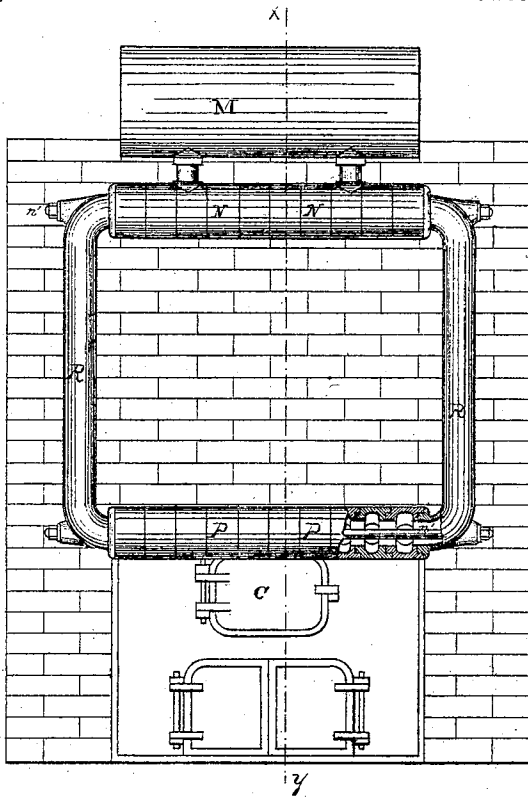

Fig. 5

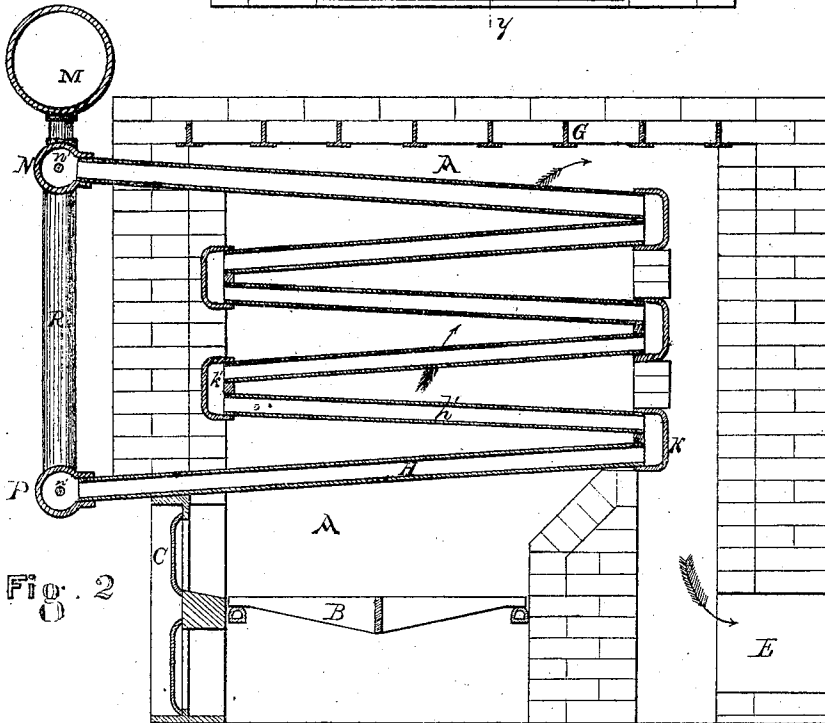
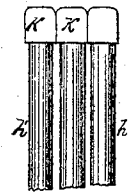

Fig. 2

Witnesses { *John S. Grant*
Mark W. Holland } *Henry B. Pancoast and*
Francis J. Maule.
by Edward Brown attorney

UNITED STATES PATENT OFFICE.

HENRY B. PANCOAST AND FRANCIS I. MAULE, OF PHILADELPHIA, PA.

IMPROVEMENT IN SECTIONAL STEAM-BOILERS.

Specification forming part of Letters Patent No. 136,453, dated March 4, 1873.

To all whom it may concern:

Be it known that we, HENRY B. PANCOAST and FRANCIS I. MAULE, both of Philadelphia, Pennsylvania, have invented certain Improvements in Sectional Steam-Boilers, of which the following is a specification:

Our invention relates to that class of steam-boilers known as sectional wrought-iron tubular boilers; and it may be briefly described as consisting of wrought-iron tubes arranged horizontally or inclined in a fire-chamber, the rear ends being connected by return bends. The top and bottom tubes of the series project through the front wall, and are secured to cast-iron rings, which fit into each other and are held together by longitudinal bolts passing through them, one bolt passing through the top row and the other bolt through the bottom row. The top row of rings is connected to the bottom row by side pipes to complete the circulation.

Referring to the drawing, Figure 1 is a front elevation. Fig. 2 is a section on X Y. Fig. 3 is a plan of tubes at the rear.

A is the fire-chamber; B, the fire-bars; C, the fire-door; E, the flue to chimney; G are iron girders to carry the roof of the furnace or fire-chamber. The lower row of tubes H project through the front just above the fire-door. They are inclined upward to the rear, where they enter the return bend K. Another row of tubes, *h'*, pass from the return bend to the front, (inclining upward sufficiently to create the necessary circulation,) where they enter the return bend *h'*, and so on backward and forward as many turns as may be necessary. The top row of tubes pass out through the front wall, where each tube is secured to a separate cast-iron ring, N. These rings are rabbeted so as to make a joint laterally, and are held together by the long bolts *n'*. Two of the rings have branches cast on, by which they are connected to the steam-drum M. The form

of this series of rings is shown in section in Fig. 1. The lower row of tubes H are connected in like manner to the rings P, which are bolted together the same as the upper row. The top row of rings N and the bottom row P are connected by the circulating pipes R, through which the water falls to the bottom row of tubes, and the circulation is complete. The same bolts *n'* which pass through the rings N and P also pass through the pipes R, holding them in steam-tight contact. In Fig. 3 is shown a plan of the tubes at the rear. The return bends K are placed in contact sidewise, so as to prevent the passage of the heated gases into the flue at the rear. The bends are of sufficient width to leave a passage between the wrought-iron tubes for the upward current of heated air and gases. The rings N can also be bolted together by two long bolts passing outside, in place of the single bolt inside.

This mode of connecting the tubes and return bends by rings and bolts so as to form a sectional manifold makes the boiler economical in transportation, and easily erected and repaired; and it can easily be enlarged by additional sections bolted on laterally.

What we claim is—

1. The arrangement and combination of the tubes H *h'*, the return bends K, and the rings N P, bolted together, as and for the purpose herein described.

2. The arrangement and combination of the tubes H *h'*, the return bends K, the manifolds composed of the rings N P bolted together, and the circulating pipes R, operating so as to form a sectional steam-boiler, as herein described.

HENRY B. PANCOAST.
FRANCIS I. MAULE.

Witnesses:

EDWD. BROWN,
FREDERIC H. SHARPLESS.