



(86) Date de dépôt PCT/PCT Filing Date: 2001/01/19  
 (87) Date publication PCT/PCT Publication Date: 2001/08/09  
 (45) Date de délivrance/Issue Date: 2010/10/19  
 (85) Entrée phase nationale/National Entry: 2002/07/16  
 (86) N° demande PCT/PCT Application No.: KR 2001/000097  
 (87) N° publication PCT/PCT Publication No.: 2001/057217  
 (30) Priorité/Priority: 2000/01/19 (KR2000-2434)

(51) Cl.Int./Int.Cl. *C12N 15/21* (2006.01),  
*C07K 14/245* (2006.01), *C07K 14/56* (2006.01),  
*C12N 15/70* (2006.01)

(72) Inventeurs/Inventors:  
KWON, SE CHANG, KR;  
JUNG, SUNG YOUB, KR;  
CHOI, KI DOO, KR;  
KIM, CHA SOON, KR;  
BAE, SUNG MIN, KR;  
LEE, GWAN SUN, KR

(73) Propriétaire/Owner:  
HANMI PHARM. CO. LTD., KR

(74) Agent: CASSAN MACLEAN

(54) Titre : VECTEUR D'EXPRESSION ET DE SECRETION POUR L'INTERFERON HUMAIN ALPHA ET PROCEDE D'OBTENTION DE L'INTERFERON HUMAIN ALPHA AU MOYEN DUDIT VECTEUR  
 (54) Title: EXPRESSION AND SECRETION VECTOR FOR HUMAN INTERFERON ALPHA AND PROCESS FOR PRODUCING HUMAN INTERFERON ALPHA BY EMPLOYING SAME

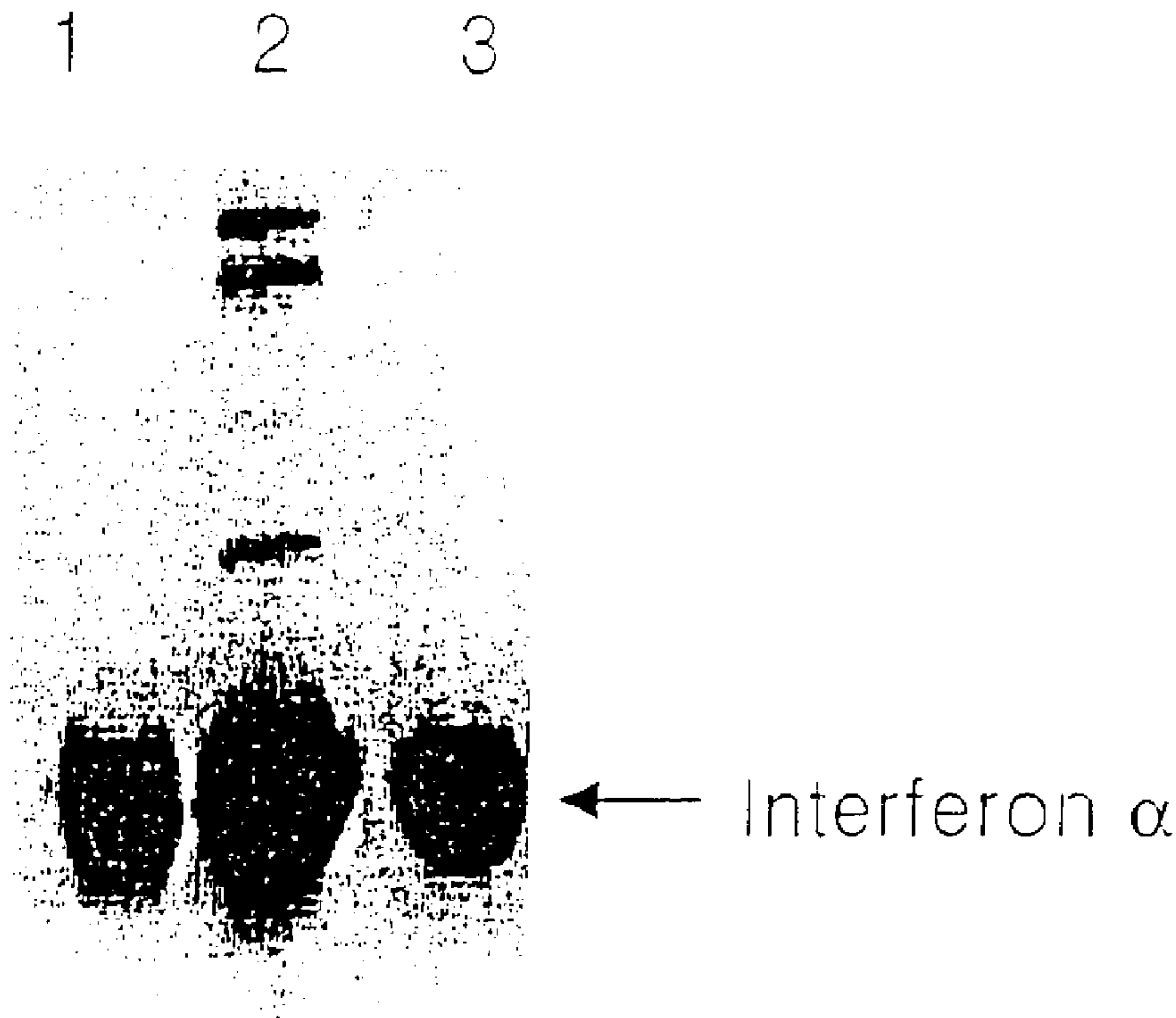

(57) Abrégé/Abstract:

Disclosed in this invention are: an expression vector for the secretive production of human interferon alpha (hIFN $\alpha$ ) comprising a polynucleotide encoding a modified E. coli thermostable enterotoxin II signal sequence and a polynucleotide encoding hIFN $\alpha$  ligated to the 3'-end thereof; a microorganism transformed with the expression vector; and a process for secretively producing human interferon by culturing the microorganism, said process being capable of secreting a soluble form of active hIFN $\alpha$ , which does not contain an additional methionine residue at its N-terminal, into the periplasm of an E. coli cell.

## (12) INTERNATIONAL APPLICATION PUBLISHED UNDER THE PATENT COOPERATION TREATY (PCT)

(19) World Intellectual Property Organization  
International Bureau(43) International Publication Date  
9 August 2001 (09.08.2001)

PCT

(10) International Publication Number  
**WO 01/57217 A1**(51) International Patent Classification<sup>7</sup>: C12N 15/21

(21) International Application Number: PCT/KR01/00097

(22) International Filing Date: 19 January 2001 (19.01.2001)

(25) Filing Language: Korean

(26) Publication Language: English

(30) Priority Data:  
2000-2434 19 January 2000 (19.01.2000) KR(71) Applicant (for all designated States except US): HANMI  
PHARM. CO. LTD. [KR/KR]; #893-5, Hajeo-ri, Paltan-  
myeon, Hwaseong-gun, Kyungki-do 445-910 (KR).

(72) Inventors; and

(75) Inventors/Applicants (for US only): KWON, Se,  
Chang [KR/KR]; 5-201 Hanyang Apt., #789, Shi-  
hung-1-dong, Gumcheon-gu, Seoul 153-031 (KR).  
JUNG, Sung, Youb [KR/KR]; 504-1402 Geoyeo Apt.,  
#294, Geoyeo-2-dong, Songpa-gu, Seoul 138-112 (KR).  
CHOI, Ki, Doo [KR/KR]; 601-407 Gaepo JugongApt., Gaepo-3-dong, Gangnam-gu, Seoul 135-243 (KR).  
KIM, Cha, Soon [KR/KR]; 106-903 Poonglim Apt.,  
#664, Poongdukcheon-lee, Suji-eup, Yongin-shi, Gy-  
onggi-do449-840 (KR). BAE, Sung, Min [KR/KR]; 303,  
#1587-8, Bongcheon-4-dong, Kwanak-gu, Seoul 151-054  
(KR). LEE, Gwan, Sun [KR/KR]; 2-806 Kukdong Apt.,  
Garak-dong, Songpa-gu, Seoul 138-160 (KR).(74) Agents: JANG, Seong, Ku et al.; First Law Offices of Ko-  
rea, 17th Fl., KEC Building, #275-7, Yangjae-dong, Seo-  
cho-ku, Seoul 137-130 (KR).(81) Designated States (national): AU, BR, CA, CN, JP, NZ,  
RU, SG, US.(84) Designated States (regional): European patent (AT, BE,  
CH, CY, DE, DK, ES, FI, FR, GB, GR, IE, IT, LU, MC,  
NL, PT, SE, TR).

Published:

— with international search report

For two-letter codes and other abbreviations, refer to the "Guid-  
ance Notes on Codes and Abbreviations" appearing at the begin-  
ning of each regular issue of the PCT Gazette.(54) Title: EXPRESSION AND SECRETION VECTOR FOR HUMAN INTERFERON ALPHA AND PROCESS FOR PRODUC-  
ING HUMAN INTERFERON ALPHA BY EMPLOYING SAME

1 2 3

← Interferon  $\alpha$ (57) Abstract: Disclosed in this invention are: an expression vector for the secre-  
tive production of human interferon alpha (hIFN $\alpha$ ) comprising a polynucleotide  
encoding a modified *E. coli* thermostable enterotoxin II signal sequence and a  
polynucleotide encoding hIFN $\alpha$  ligated to the 3'-end thereof; a microorganism  
transformed with the expression vector; and a process for secretively producing  
human interferon by culturing the microorganism, said process being capable of  
secreting a soluble form of active hIFN $\alpha$ , which does not contain an additional  
methionine residue at its N-terminal, into the periplasm of an *E. coli* cell.

WO 01/57217 A1

**EXPRESSION AND SECRETION VECTOR FOR HUMAN  
INTERFERON ALPHA AND PROCESS FOR PRODUCING  
HUMAN INTERFERON ALPHA BY EMPLOYING SAME**

5 **Field of the Invention**

The present invention relates to an expression vector for the secretive production of human interferon alpha (hIFN $\alpha$ ) comprising a polynucleotide encoding a modified *E.coli* thermostable enterotoxin II signal sequence and a  
10 polynucleotide encoding hIFN $\alpha$  ligated to the 3'-end thereof; a microorganism transformed with the expression vector; and a process for secretively producing hIFN $\alpha$  having no methionine residue added at its N-terminal in the periplasm of *E.coli* cell.

15 **Background of the Invention**

Isaacs and Lindenmann reported in 1957 that when chicken is infected with influenza virus A, a viral replication inhibitory factor designated interferon is produced (Isaacs, K and Lindenmann, *J. Proc. R.*  
20 *Soc. Lond.*, B147:258-267, 1957).

Human interferons are cytokine proteins which inhibit *in vivo* immune response or viral replication and they are classified as interferon alpha (IFN $\alpha$ ), interferon beta (IFN $\beta$ ) and interferon gamma (IFN $\gamma$ ) according to cell types producing them (Kirchner, H. et al., *Tex. Rep. Biol. Med.*, 41:89-  
25 93, 1981; Stanton, G. J. et al., *Tex. Rep. Biol. Med.*, 41:84-88, 1981).

It is well-known that these interferons work together to exert synergic effects in the manifestation of anti-viral, anti-cancer, NK (natural killer) cell activation and marrow cell inhibition activities (Klimpel, et al., *J. Immunol.*, 129:76-78, 1982; Fleischmann, W. R. et al., *J. Natl. Cancer Inst.*,  
30 65:863-966, 1980; Weigent, et al., *Infec. Immun.*, 40:35-38, 1980). In addition, interferons act as regulatory factors of the expression, structure and function of genes in the cell, and show a direct anti-proliferating effect.

IFN $\alpha$  is produced when leukocyte is stimulated by B cell mitogen, virus or cancer cells. Up to now, there have been reported genes that encode more than 20 species of interferons, each comprising 165 or 166 amino acids.

5 IFN $\alpha$  used for early clinical tests were obtained from buffy coat leukocyte stimulated by Sendai virus and its purity was only less than 1% (Cantell, K. and Hirvonen, *Tex. Rep. Biol. Med.*, 35:138-144, 1977).

It has become possible to produce a large quantity of IFN $\alpha$  having biophysical activity by gene recombinant techniques in the 1980' (Goedell, 10 D. V. et al., *Nature*, 287:411-416, 1980). Clinical tests using the recombinant hIFN $\alpha$  have shown that it is effective in treating various solid cancers, particularly bladder cancer, kidney cancer, HIV related Kaposi's sarcoma, etc. (Torti, F. M., *J. Clin. Oncol.*, 6:476-483, 1988; Vugrin, D., et al., *Cancer Treat. Rep.*, 69:817-820, 1985; Rios, A., et al., *J. Clin. Oncol.*, 15 3:506-512, 1985). It is also effective for the treatment of hepatitis C virus (Davis, G. G., et al., *N. Engl. J. Med.*, 321:1501-1506, 1989), and its applicable range as a therapeutic agent is expanding day by day.

The result of cloning IFN $\alpha$  gene from leukocyte has shown that IFN $\alpha$  is encoded by a group of at least 10 different genes. This indicates 20 that the DNA sequences of the genes do not produce one kind of protein but that IFN $\alpha$  is a mixture of subtype proteins having similar structures. Such subtype proteins are named IFN $\alpha$ -1, 2, 3, and so on (*Nature*, 290:20-26, 1981).

Among the several types of interferons, hIFN $\alpha$  purified from human 25 leukocyte has a molecular weight of 17,500 to 21,000, and a very high native activity of about  $2 \times 10^8$  IU/mg protein. *In vivo* IFN $\alpha$  is a protein consisting of 165 amino acids. It is designated IFN $\alpha$ -2a (SEQ ID NO : 1) in case the 23<sup>rd</sup> amino acid is lycine, and IFN $\alpha$ -2b (SEQ ID NO : 2) in case the 23<sup>rd</sup> amino acid is arginine. In the beginning, hIFN $\alpha$  was produced by a 30 process using a cell culture method. However, this process is unsuitable for commercialization because of its low productivity of about 250 ug/L.

To solve this problem, processes for recovering a large quantity of

interferon from microorganisms by using gene recombinant techniques have been developed and used to date.

The most widely employed is a process using *E.coli* which produces IFN $\alpha$  consisting of 166 or 167 amino acids according to the characteristics  
5 of the *E.coli* cell. These products have an extra methionine residue added at the N-terminal by the action of the ATG codon existing at the site of initiation codon. However, it has been reported that the additional methionine residue can trigger harmful immune response, in the case of human growth hormone (EP Patent Publication No. 256,843).

10 In addition, most of the expressed IFN $\alpha$  accumulates in cytoplasm in the form of insoluble inclusion bodies and must be converted into an active form through refolding during a purification process. As such a refolding process is not efficient, IFN $\alpha$  exists partially in a reduced form, or forms an intermolecular disulfide coupling body or a defective disulfide coupling body.  
15 It is difficult to remove these by-products, which cause a markedly low yield. In particular, it is extremely difficult to remove undesirable interferon by-products such as misfolded interferons.

Recently, in order to solve the above mentioned problems associated with the production of a foreign protein within a microbial cell, various  
20 efforts have been made to develop a method based on efficient secretion of a soluble form of the target protein carrying no extra methionine added to the N-terminal.

In this method, a desired protein is expressed in the form of a fusion protein which carries a signal peptide attached to its N-terminal. When the  
25 fusion protein passes through the cell membrane, the signal peptide is removed by an enzyme in *E.coli* and the desired protein is secreted in a native form.

The secretive production method is more advantageous than the microbial production method in that the amino acid sequence and the higher  
30 structure of the produced protein are usually identical to those of the wild-type. However, the yield of a secretive production method is often quite low due to its unsatisfactory efficiencies in both the membrane transport and

the subsequent purification process. This is in line with the well-known fact that the yield of a mammalian protein produced in a secretory mode in prokaryotes is much lower than that of a prokaryotic protein produced in the same mode in prokaryotes. Therefore, it has been attempted to develop a more efficient secretory production method. For instance, Korean Patent  
5 Publication No. 93-1387 discloses an attempt to mass-produce IFN $\alpha$  using the signal peptide of *E.coli* alkaline phosphatase, but the yield was very low at 10<sup>9</sup> IU/L culture medium (10 ug/L culture medium). Therefore, there has been a keen interest in developing a method which is capable of producing  
10 soluble IFN $\alpha$  having no additional methionine residue added at the N-terminal, using a microorganism on a large scale.

The present inventors have previously generated a new signal peptide of *E.coli* thermostable enterotoxin II (Korean Patent Application No. 98-38061 and 99-27418) and found that this new secretory signal peptide can  
15 be used for the mass-production of the native form of IFN $\alpha$ . Namely, the present inventors have constructed an expression vector containing a gene obtained by ligating IFN $\alpha$  encoding gene instead of enterotoxin II encoding gene to the modified *E.coli* secretory signal peptide, and developed a secretory production method of IFN $\alpha$  having a native biological activity via  
20 the microbial secretory system by culturing the microorganism transformed with said expression vector.

### **Summary of the Invention**

25 Accordingly, it is an object of the present invention to provide an expression vector which can secretively produce human interferon alpha (hIFN $\alpha$ ).

It is another object of the present invention to provide a microorganism transformed with said expression vector.

30 It is a further object of the present invention to provide a process for producing a soluble form of hIFN $\alpha$  using said microorganism, which has no extra methionine residue attached to the amino terminus.

### **Brief Description of the Drawings**

The above and other objects and features of the present invention will become apparent from the following description of the invention taken in conjunction with the following accompanying drawings; which respectively show:

- Fig. 1 : the procedure for constructing vector pT-IFN $\alpha$ -2a;  
10 Fig. 2 : the procedure for constructing vector pT14SI $\alpha$ -2a;  
Fig. 3 : the procedure for constructing vector pT14SSI $\alpha$ -2a;  
Fig. 4 : the procedure for constructing vector pT140SSI $\alpha$ -2a-4T22Q;  
15 Figs. 5a and 5b : the results of SDS-PAGE which verify the expression of IFN $\alpha$ -2a and the purity of the expressed IFN $\alpha$ -2a from recombinant cell lines, and the result of western blot analysis which verifies the molecular weight of expressed IFN $\alpha$ -2b, respectively.

### **Detailed Description of the Invention**

20 According to one aspect of the present invention, there is provided an expression vector for the secretive production of hIFN $\alpha$  comprising a polynucleotide encoding a modified thermostable enterotoxin II signal sequence (hereinafter, as referred as to 'STII mutant') and a polynucleotide encoding hIFN $\alpha$  ligated to the 3'-end thereof.

25 The polynucleotide encoding hIFN $\alpha$  used for constructing the expression vector of the present invention may be any one of polynucleotides encoding random hIFN $\alpha$  subtypes such as native hIFN $\alpha$ -2a (SEQ ID NO : 1), IFN $\alpha$ -2b (SEQ ID NO : 2), IFN $\alpha$ -1 and IFN $\alpha$ -3, and it may also be a recombinant polynucleotide which has a modified base sequence that  
30 encodes any of the above IFN $\alpha$  subtypes.

The polynucleotide encoding the modified *E.coli* thermostable enterotoxin II signal sequence of the present invention, which is ligated to

the front of the 5'-end of the polynucleotide encoding hIFN $\alpha$  and used for the purpose of the secretive production of hIFN $\alpha$ , may be a polynucleotide encoding a mutant derivable by replacing one or more of the amino acids of *E.coli* thermostable enterotoxin II signal sequence described in SEQ ID NO :  
5 3, preferably one or more of the 4<sup>th</sup>, 20<sup>th</sup> and 22<sup>nd</sup> amino acids thereof with other amino acid(s). Examples of such polynucleotides encode mutants obtained by replacing: the 4<sup>th</sup> amino acid with threonine ([Thr<sup>4</sup>]STII); the 4<sup>th</sup> amino acid with threonine and the 22<sup>nd</sup> amino acid with glutamine, respectively ([Thr<sup>4</sup>, Gln<sup>22</sup>]STII); the 4<sup>th</sup> amino acid with threonine, the 20<sup>th</sup>  
10 amino acid with valine and the 22<sup>nd</sup> amino acid with glutamine, respectively ([Thr<sup>4</sup>, Val<sup>20</sup>, Gln<sup>22</sup>]STII); and the 4<sup>th</sup> amino acid with threonine and the 20<sup>th</sup> amino acid with valine, respectively ([Thr<sup>4</sup>, Val<sup>20</sup>]STII) in the *E.coli* thermostable enterotoxin II signal sequence (STII) described in the SEQ ID NO : 3, and preferred polynucleotide sequences are SEQ ID NOS : 4, 5, 6  
15 and 7. However, it is known that several different polynucleotides encoding the mutants of the present invention may exist due to the codon degeneracy, and, specifically, a polynucleotide modified by introducing preferred codons of *E.coli* without any change of amino acid sequence can be used for promoting the expression rate of IFN $\alpha$ .

20 In addition, the expression vector of the present invention may further comprise *E.coli* thermostable enterotoxin II Shine-Dalgarno sequence (SD sequence, SEQ ID NO :8) or its mutant ligated to the front of the 5'-end of the polynucleotide encoding the modified thermostable enterotoxin II signal sequence. As compared with an wild-type which has 7 bases  
25 (TGATTTT) following GAGG of the 5'-end in the *E.coli* thermostable enterotoxin II SD sequence described in the SEQ ID NO : 8, the mutant of SD sequence has a shorter sequence of 6 or 5 bases. The use of this mutant can increase the secretive expression rate of IFN $\alpha$ . However, when said base sequence becomes shorter than 4 bases, the expression rate decreases  
30 markedly. A specific example of a preferred mutant that can be used in the present invention is the *E.coli* thermostable enterotoxin II SD sequence mutant having the nucleotide sequence of SEQ ID NO : 9.

The promoter used in preparing the expression vector of the present invention may be any of those which can express a heterologous protein in a microorganism host. Specifically, lac, Tac, and arabinose promoter is preferred when the heterologous protein is expressed in *E.coli*.

5 This invention also provides transformed microorganisms which may be obtained e.g., by transforming such *E.coli* strains as *E.coli* BL21(DE3) (Novagen, USA) or *E.coli* XL-1 blue (Novagen, USA) with said expression vector. Examples of the present invention provide such transformed microorganisms: *E.coli* BL21(DE3)/pT140SSI $\alpha$ -2a-4T ("HM 10603"),  
10 *E.coli* BL21(DE3)/pT140SSI $\alpha$ -2a-4T22Q ("HM 10611"), *E.coli* BL21(DE3)/pT140SSI $\alpha$ -2b-4T ("HM 10703") and *E.coli* BL21(DE3)/pT140SSI $\alpha$ -2b-4T22Q ("HM 10711"). The above transformed microorganisms are deposited in Korean Culture Center of Microorganisms (KCCM) (Address; Yurim Bldg., 361-221, Hongje 1-dong, Seodaemun-gu,  
15 Seoul 120-091, Republic of Korea) on December 23, 1999 under accession numbers KCCM-10175, KCCM-10176, KCCM-10177 and KCCM-10178, respectively, in accordance with the terms of the Budapest Treaty on the International Recognition of the Deposit of Microorganism for the Purpose of Patent Procedure.

20 In accordance with another aspect of this invention, there is also provided a process for secretively producing hIFN $\alpha$  having no additional methionine residue attached at the N-terminal, into the periplasm of *E.coli* by culturing the transformed microorganism under an appropriate culture condition which may be the same as the conventional culture condition used  
25 for transformed microorganisms.

hIFN $\alpha$  secretively produced by the process of the present invention comprises random hIFN $\alpha$  subtypes such as IFN $\alpha$ -1, IFN $\alpha$ -3 and so on, as well as native hIFN $\alpha$ -2a (SEQ ID NO : 1) and hIFN $\alpha$ -2b (SEQ ID NO : 2) consisting of 165 amino acids. In addition, the process of the present  
30 invention can be applied to the production of any other interferon such as hIFN $\beta$  and hIFN $\gamma$ .

According to the process of the present invention, 80% or more of

IFN $\alpha$  produced by the inventive *E.coli* transformant is secreted into the periplasm at a high productivity of more than 1 g/L. The produced IFN $\alpha$  has the same amino acid sequence as that of native IFN $\alpha$  which has no additional amino acid attached at the N-terminal, and shows a biological  
5 activity equal to that of native IFN $\alpha$ .

The following Examples are included to further illustrate the present invention without limiting its scope.

10 **Reference Example : IFN $\alpha$ -2a gene and construction of a vector containing same**

A gene encoding hIFN $\alpha$ -2a was prepared by carrying out PCR using human genomic DNA as a template and SEQ ID NOS : 10 and 11 as primers.  
15 The primer of SEQ ID NO : 10 was designed to provide an NdeI restriction site (5'-CATATG-3') upstream from the codon for the first amino acid (cysteine) codon of native hIFN $\alpha$ , and the primer of SEQ ID NO : 11, to provide a BamHI restriction site (5'-GGATCC-3') downstream from the termination codon thereof.

20 The amplified PCR product was cleaved with NdeI and BamHI to obtain a DNA fragment encoding hIFN $\alpha$ -2a. The DNA fragment was inserted into the NdeI/BamHI site of vector pET-14b (Novagen, USA) to obtain vector pT-IFN $\alpha$ -2a.

25 Fig. 1 shows the above procedure for constructing vector pT-IFN $\alpha$ -2a.

**Comparative Example 1: Construction of a vector containing enterotoxin signal sequence and IFN $\alpha$ -2a genes**

30 To prepare *E.coli* enterotoxin II signal sequence gene, the pair of complementary oligonucleotides of SEQ ID NOS : 12 and 13 were designed based on the previously known nucleotide sequence of *E.coli* enterotoxin II

signal peptide, and synthesized using a DNA synthesizer (Model 380B, Applied Biosystem, USA). The above oligonucleotides were designed to provide a BspHI restriction site (complementary sites to an NdeI restriction site) upstream from the initiation codon of *E.coli* enterotoxin II and a MluI restriction site introduced by a silent change at the other end. Both  
5 oligonucleotides were annealed at 95°C to obtain a blunt-ended DNA fragment having a nucleotide sequence encoding *E.coli* enterotoxin II signal sequence. The above DNA fragment was inserted into the SmaI site of vector pUC19 (BioLabs, USA) to obtain vector pUC19ST.

10 In addition, vector pT-IFN $\alpha$ -2a containing IFN $\alpha$ -2a gene obtained in Reference Example was subjected to PCR using the primers of SEQ ID NOS : 14 and 15 to ligate the enterotoxin signal peptide to IFN $\alpha$ -2a gene. The primer of SEQ ID NO : 14 was designed to correspond to the 5'-end of IFN $\alpha$ -2a gene, and the primer of SEQ ID NO : 15, to provide a BamHI  
15 restriction site (5'-GGATCC-3') downstream from the termination codon thereof. The DNA fragment containing the polynucleotide, which encodes native IFN $\alpha$ -2a, was amplified by PCR using the above polynucleotide primers. The amplified DNA fragment was cleaved with MluI and BamHI to obtain an IFN $\alpha$ -2a DNA fragment having MluI/BamHI ends.

20 Meanwhile, vector pUC19ST containing the enterotoxin signal peptide was cleaved with MluI and then digested with BamHI to obtain a vector fragment having MluI/BamHI ends. The vector fragment was ligated to the IFN $\alpha$ -2a DNA fragment to construct vector pUC19SIFN $\alpha$ -2a.

25 Vector pUC19SIFN $\alpha$ -2a was cleaved with BspHI and BamHI to obtain a DNA fragment (564 bp). The DNA fragment was inserted at the NcoI/BamHI section of vector pET-14b (Novagen, USA) to obtain vector pT14SI $\alpha$ -2a. Fig. 2 shows the above procedure for constructing vector pT14SI $\alpha$ -2a.

30 Subsequently, *E.coli* BL21(DE3) strain was treated with 70 mM calcium chloride solution to prepare competent *E.coli*, and then, vector pT14I $\alpha$ -2a in 10 mM Tris buffer (pH 7.5) was added thereto. An *E.coli* transformant expressing IFN $\alpha$ -2a was selected by a conventional method

which exploits the sensitivity of the transformed vector toward antibiotics, and designated *E.coli* HM 10600.

In addition, vector pT14SI $\alpha$ -2a was subjected to PCR using the primers of SEQ ID NOS : 16 and 17 to amplify a DNA fragment obtained by  
5 ligating the Shine-Dalgarno sequence of the enterotoxin, the enterotoxin signal peptide, and IFN $\alpha$ -2a gene, in that order, and then the DNA fragment was cleaved with XbaI and BamHI to obtain an insert.

The insert was ligated into the XbaI/BamHI section of vector pET-14b (Novagen, USA) to construct vector pT14SSI $\alpha$ -2a. Fig. 3 displays the  
10 above procedure for constructing vector pT13SSI $\alpha$ -2a. *E.coli* BL21(DE3) (Stratagene, USA) was transformed with vector pT14SSI $\alpha$ -2a to obtain a transformant designated *E.coli* HM 10601.

**Comparative Example 2: Construction of a vector containing**  
15 **enterotoxin signal sequence and IFN $\alpha$ -2b genes**

The 23<sup>rd</sup> lysine codon of IFN $\alpha$ -2a gene in vector pT14SSI $\alpha$ -2a was replaced by arginine codon with a site-directed mutagenesis (Papworth, C. et al., *Stratagies*, 9, 3, 1996) to construct an expression vector containing  
20 IFN $\alpha$ -2b gene. Vector pT14SSI $\alpha$ -2a was subjected to hybridization with the synthetic oligonucleotides of SEQ ID NOS : 19 and 20 containing the replaced codon to form a hybrid molecule and DNA amplification was performed using pfu (Stratagene, USA) and four nucleotide triphosphates (ATP, GTP, TTP, CTP) which extend said oligonucleotides in the 5'-3'  
25 direction.

Interferon  $\alpha$ -2b sequence

	17	18	19	20	21	22	23	24	25	26	27	28	29	
	Leu	Leu	Ala	Gln	Met	Arg	<b>Arg</b>	Ile	Ser	Leu	Phe	Ser	Cys	(SEQ ID NO:18)
30	CTC	CTG	GCA	CAG	ATG	AGG	<b>AGA</b>	ATC	TCT	CTT	TTC	TCC	TGC	(SEQ ID NO:19)
	GCA	GGA	AGG	AAG	AGA	GAT	<b>TCT</b>	CCT	CAT	CTG	TGC	CAG	GAG	(SEQ ID NO:20)

The amplified DNA fragment was recovered and a restriction enzyme DpnI was added thereto to remove unconverted plasmids completely.

*E. coli* XL-1 blue (Novagen, USA) was transformed with the modified plasmid. The base sequence of the DNA recovered from transformed colonies was determined, and thus obtained was plasmid pT14SSI $\alpha$ -2b which contained a gene having arginine in place of the 23<sup>rd</sup> amino acid lysine of IFN $\alpha$ -2a.

Subsequently, *E. coli* BL21(DE3) was transformed with the modified vector pT14SSI $\alpha$ -2b to obtain a transformant designated *E. coli* HM10701 by using the same method described in Comparative Example 1. By analyzing the N-terminal amino acid sequence of the protein produced by culturing the transformant, it has been confirmed that IFN $\alpha$ -2b having the native amino acid sequence was expressed therefrom.

### Example 1: Construction of a vector containing enterotoxin signal peptide mutant

#### (1) Construction of a vector containing [Thr<sup>4</sup>]STII

In order to modify a specific amino acid residue of the enterotoxin signal sequence peptide, a vector containing a polynucleotide encoding enterotoxin mutant signal sequence was prepared by site-directed mutagenesis as follows.

First, vector pT14SSI $\alpha$ -2a obtained in Comparative Example 1 was subjected to PCR using oligonucleotides of SEQ ID NOS : 22 and 23 to obtain a modified plasmid, wherein the 4<sup>th</sup> amino acid of the enterotoxin signal sequence is replaced with threonine (Thr), by the site-directed mutagenesis procedure described in Comparative Example 2.

Met Lys Lys **Thr** Ile Ala Phe Leu (SEQ ID NO:21)  
 5'-GGTGATTTT ATG AAA AAG **ACA** ATC GCA TTT CTT C-3' (SEQ ID NO:22)  
 3'-CCACTAAAA TAC TTT TTC **TGT** TAG CGT AAA GAA G-5' (SEQ ID NO:23)

Then, *E.coli* XL-1 blue (Novagen, USA) was transformed with the modified plasmid. The base sequence of DNA recovered from the transformed colonies was determined, and thus obtained was a plasmid  
 5 which contained a gene encoding the enterotoxin signal sequence peptide having Thr in the 4<sup>th</sup> amino acid position thereof. The plasmid thus obtained was cleaved with XbaI and MluI, and then inserted into the XbaI/MluI section of vector pT14SSI $\alpha$ -2a to obtain vector pT14SSI $\alpha$ -2a-4T.

Subsequently, *E.coli* BL21(DE3) (Stratagene, USA) was transformed  
 10 with vector pT14SSI $\alpha$ -2a-4T to obtain an *E.coli* transformant designated *E.coli* HM 10602.

Vector pT14SSI $\alpha$ -2a-4T was constructed using pT14SSI $\alpha$ -2b, and then transformed into *E.coli* BL21(DE3) (Stratagene, USA) to obtain an *E.coli* transformant designated *E.coli* HM 10702 by the same method  
 15 described above.

## (2) Construction of a vector containing [Thr<sup>4</sup>, Gln<sup>22</sup>]STII

Vector pT14SSI $\alpha$ -2a-4T obtained in step (1) was subjected to PCR  
 20 using the oligonucleotides of SEQ ID NOS : 25 and 26, which were designed to substitute Gln codon for the 22<sup>nd</sup> amino acid of the enterotoxin signal peptide having Thr in its 4<sup>th</sup> position, in accordance with the site-directed mutagenesis procedure of step (1) to obtain a modified plasmid.

25 Asp Ala **Gln** Ala Cys Asp Leu Pro (SEQ ID NO:24)  
 5'-CA ATT GCC **CAA** GCG TGT GAT CTG CCT-3' (SEQ ID NO:25)  
 3'-GT TTA CGG **GTT** CGC ACA CTA GAC GGA-5' (SEQ ID NO:26)

Then, *E.coli* XL-1 blue (Novagen, USA) was transformed with the  
 30 modified plasmid. The base sequence of DNA recovered from transformed colonies was determined, and thus obtained was plasmid pT14SSI $\alpha$ -2a-4T22Q which contained a gene having Thr and Gln in the 4<sup>th</sup> and 22<sup>nd</sup> amino

acid positions of the enterotoxin signal sequence, respectively. Subsequently, *E.coli* BL21(DE3) (Stratagen, USA) was transformed with vector pT14SSI $\alpha$ -2a-4T22Q by the same method described in step (1) to obtain a transformant designated *E.coli* HM 10604.

5 To modify the Shine-Dalgarno sequence of the modified enterotoxin signal sequence into SEQ ID NO : 9, vectors pT14SSI $\alpha$ -2a-4T and pT14SSI $\alpha$ -2a-4T22Q were subjected to the site-directed mutagenesis procedure described in step (2) using the oligonucleotides of SEQ ID NOS : 27 and 28 to obtain the desired modified plasmid.

10 *E.coli* XL-1 blue (Novagen, USA) was transformed with the modified plasmid. The base sequence of the DNA recovered from transformed colonies was determined, and thus obtained were plasmids pT14OSSI $\alpha$ -2a-4T and pT14OSSI $\alpha$ -2a-4T22Q having modified Shine-Dalgarno sequence of enterotoxin signal sequence. Fig. 4 represents the  
15 above procedure for constructing vector pT14OSSI $\alpha$ -2a-4T22Q.

*E.coli* BL21(DE3) was transformed with vector pT14OSSI $\alpha$ -2a-4T and pT14OSSI $\alpha$ -2a-4T22Q, respectively, to obtain a transformant designated *E.coli* HM 10603 and HM 10611, which were deposited in Korean Culture Collection of Microorganisms (KCCM) on December 23, 1999 under  
20 accession numbers KCCM-10175 and KCCM-10176, respectively.

In addition, vectors pT14OSSI $\alpha$ -2b-4T and pT14OSSI $\alpha$ -2b-4T22Q were prepared by the same procedure as above using vector pT14SSI $\alpha$ -2b, which were used to transform *E.coli* BL21(DE3) to obtain transformants designated *E.coli* HM 10703 and HM 10711, respectively. *E.coli*  
25 transformants HM 10703 and HM 10711 were deposited in KCCM on December 23, 1999 under accession numbers KCCM-10177 and KCCM-10178, respectively.

### (3) Construction of a vector containing [Thr<sup>4</sup>, Val<sup>20</sup>, Gln<sup>22</sup>]STII

30

To further substitute Val codon for the 20<sup>th</sup> amino acid of the enterotoxin signal sequence peptide having Thr and Gln in its 4<sup>th</sup> and 22<sup>nd</sup>

amino acid positions, vectors pT14OSSII $\alpha$ -2a-4T22Q and pT14OSSII $\alpha$ -2b-4T22Q prepared in step (2) were subjected to PCR using the oligonucleotides of SEQ ID NOS : 29 and 30 by the site-directed mutagenesis procedure described in step (2), to obtain the desired modified  
5 plasmids designated pT14OSSII $\alpha$ -2a-4T20V22Q and pT14OSSII $\alpha$ -2b-4T20V22Q.

*E.coli* XL-1 blue was transformed with the modified plasmids. The base sequences of the DNAs recovered from transformed colonies were determined, and thus obtained were plasmids pT14OSSII $\alpha$ -2a-4T20V22Q  
10 and pT14OSSII $\alpha$ -2b-4T20V22Q which contained a gene having Thr, Val and Gln codons in places of the 4<sup>th</sup> Asp, 20<sup>th</sup> Asp and 22<sup>nd</sup> Tyr codons, respectively. *E.coli* BL21(DE3) was transformed with the plasmids to obtain transformants designated *E.coli* HM 10612 and HM 10712, respectively.

15

**Example 2: Preparation of thermostable enterotoxin II Shine-Dalgarno sequence mutant**

In order to reduce the number of bases between the ribosome binding  
20 site and initiation codon ATG of the modified *E.coli* thermostable enterotoxin II signal sequence within thermostable enterotoxin II Shine-Dalgarno sequence of the above-prepared expression vector, a modified plasmid was constructed by the site-directed mutagenesis procedure of Comparative Example 2.

25 Namely, to reduce the number of bases between the ribosome binding site GAGG and initiation codon ATG from 7 to 5, vector pT14OSSII $\alpha$ -2a-4T22Q prepared in Example 1 (2) was subjected to the site-directed mutagenesis procedure of Comparative Example 2 using the oligonucleotides of SEQ ID NOS : 31 and 32 to obtain a modified plasmid  
30 designated pT14NSSII $\alpha$ -2a-4T22Q. In addition, to reduce the number of bases between the ribosome binding site GAGG and initiation codon ATG to 4, vector pT14NSSII $\alpha$ -2a-4T22Q was subjected to by the site-directed

mutagenesis procedure of Comparative Example 2 using the oligonucleotides of SEQ ID NOS : 33 and 34 to obtain a modified plasmid designated pT14MSSI $\alpha$ -2a-4T22Q.

*E.coli* XL-1 blue was transformed with the modified plasmids. The base sequences of the DNAs recovered from transformed colonies were determined, and thus obtained were IFN $\alpha$  expression plasmids pT14NSSI $\alpha$ -2a-4T22Q and pT14MSSI $\alpha$ -2a-4T22Q which respectively contained 5 and 4 bases between the ribosome binding site GAGG and initiation codon ATG. *E.coli* BL21(DE3) was transformed with the expression plasmids to obtain transformants designated HM 10613 and HM 10614, respectively.

### Example 3 : Comparision of expression amount of IFN $\alpha$ -2

Transformants prepared in the above Comparative Examples and Examples were cultured in LB medium and then incubated in the presence of IPTG for 3 hours. Each of the cultures was centrifuged at 6,000 rpm for 20 min. to precipitate bacterial cells and the precipitate was treated by Osmotic shock method (Nossal, G. N., *J. Biol. Chem.*, 241:3055, 1966) as following.

The precipitate was suspended in a 1/10 volume of isotonic solution (20% sucrose, 10 mM Tris-Cl buffer containing 1 mM EDTA, pH 7.0). The suspension was allowed to stand at room temperature for 30 min, and then centrifuged to collect bacterial cells. The cells were resuspended in D.W. at 4°C to extract the proteins present in the periplasm of the cells, and centrifuged to obtain a supernatant as a periplasmic solution. The IFN $\alpha$ -2 level in the periplasmic solution was assayed in accordance with ELISA method (Kato, K. et al., *J. Immunol.*, 116, 1554, 1976) using an antibody against the IFN $\alpha$ -2 (R&D, USA), which was calculated as the amount of the IFN $\alpha$ -2a produced per 1  $\ell$  of culture. The results are shown in Table 1.

Table I : Comparision of expression amount of IFN $\alpha$ -2

Transformant	Example	Expression	Modified	IFN $\alpha$ -2
--------------	---------	------------	----------	-----------------

		Vector	amino acid residue in STII	Level in periplasm*
HM 10600	Comp. Exam. 1	PT14SI $\alpha$ -2a		82 $\pm$ 40
HM 10601	Comp. Exam. 1	PT14SSI $\alpha$ -2a		325 $\pm$ 75
HM 10701	Comp. Exam. 2	PT14SSI $\alpha$ -2b		288 $\pm$ 90
HM 10602	Example 1(1)	pT14SSI $\alpha$ -2a-4T	Thr <sup>4</sup>	550 $\pm$ 120
HM 10603	Example 1(2)	pT14OSSI $\alpha$ -2a-4T	Thr <sup>4</sup>	1,020 $\pm$ 135
HM 10604	Example 1(2)	PT14SSI $\alpha$ -2a-4T22Q	Thr <sup>4</sup> , Gln <sup>22</sup>	680 $\pm$ 105
HM 10611	Example 1(2)	pT14OSSI $\alpha$ -2a-4T22Q	Thr <sup>4</sup> , Gln <sup>22</sup>	1,220 $\pm$ 120
HM 10612	Example 1(3)	pT14OSSI $\alpha$ -2a-4T20V22Q	Thr <sup>4</sup> , Val <sup>20</sup> , Gln <sup>22</sup>	1,130 $\pm$ 180
HM 10613	Example 2	pT14NSSI $\alpha$ -2a-4T22Q	Thr <sup>4</sup> , Gln <sup>22</sup>	750 $\pm$ 144
HM 10614	Example 2	pT14MSSI $\alpha$ -2a-4T22Q	Thr <sup>4</sup> , Gln <sup>22</sup>	420 $\pm$ 100
HM 10702	Example 1(1)	pT14SSI $\alpha$ -2b-4T	Thr <sup>4</sup>	370 $\pm$ 90
HM 10703	Example 1(2)	pT14OSSI $\alpha$ -2b-4T	Thr <sup>4</sup>	735 $\pm$ 117
HM 10711	Example 1(2)	pT14OSSI $\alpha$ -2b-4T22Q	Thr <sup>4</sup> , Gln <sup>22</sup>	1,070 $\pm$ 150
HM 10712	Example 1(3)	pT14OSSI $\alpha$ -2b-4T20V22Q	Thr <sup>4</sup> , Val <sup>20</sup> , Gln <sup>22</sup>	820 $\pm$ 160
* IFN $\alpha$ mg/100 O.D <sub>600 nm</sub> /L culture solution				

#### **Example 4 : Post-treatment and purification**

According to the procedure of Example 3, transformant *E. coli* HM 10611 prepared in Example 1(2) was cultured in LB medium and the culture was centrifuged for 6,000 rpm for 20 min. to harvest cells. The periplasmic solution was prepared from the cells by the Osmotic Shock method.

The periplasmic solution was adjusted to pH 5.0 to 5.5, adsorbed on

an S-Sepharose<sup>TM</sup> (Pharmacia Inc., Sweden) column pre-equilibrated to pH 5.3, and then, the column was washed with 25 mM NaCl. IFN $\alpha$ -2 was eluted by sequentially adding acetic acid buffer solutions containing 50 mM, 100 mM, 200 mM and 1 M NaCl, respectively, and fractions containing IFN $\alpha$ -2 were collected and combined.

The combined fractions were subjected to Blue Sepharose<sup>TM</sup> (Pharmacia Inc., Sweden) column chromatography and eluted by adding to the column buffer solutions containing more than 2 M NaCl to obtain an active fraction.

The active fraction was dialyzed with a buffer, and finally subjected to resin column fractionation using a DEAE anion exchange resin column at pH 5.8 to obtain IFN $\alpha$ -2a having a purity of more than 99%. In addition, IFN $\alpha$ -2b was purified from transformant *E.coli* HM 10711 by repeating the above procedure.

Each of the purified IFN $\alpha$ -2a and IFN $\alpha$ -2b fractions was subjected to sodium dodecylsulfate polyacrylamide gel electrophoresis (SDS-PAGE) to determine the purity and approximate IFN $\alpha$  concentration, and then subjected to a conventional ELISA method as in Example 3 to determine the exact IFN $\alpha$  concentration in the periplasmic solution. In addition, it was confirmed by N-terminal amino acid sequence analysis that IFN $\alpha$ -2a and IFN $\alpha$ -2b were of the native types having no additional methionine.

#### **Example 5 : Determination of IFN $\alpha$ -2a molecular weight produced from recombinant cell lines**

The expression and molecular weights of IFN $\alpha$ -2a and IFN $\alpha$ -2b produced from recombinant cell lines were determined by using SDS-PAGE and Western blotting.

First, the periplasmic fraction of transformant *E.coli* HM 10611 prepared in Example 4 and purified IFN $\alpha$ -2a obtained therefrom were subjected to SDS-PAGE using a commercial IFN $\alpha$ -2a product (3 X 10<sup>6</sup> IU/ml) as a control according to the conventional method. Fig. 5a

reproduces the SDS-PAGE result, wherein lane 1 shows the IFN $\alpha$ -2a control; lane 2, the periplasmic fraction of *E.coli* transformant HM 10611; and lane 3, the purified IFN $\alpha$ -2a. As can be seen from Fig. 5a, the purified IFN $\alpha$ -2a had the same molecular weight as that of the native IFN $\alpha$ -2a, and was present in the periplasmic fraction of transformant *E.coli* HM 10611 at a high level.

In addition, the periplasmic fraction of transformant *E.coli* HM 10711, a purified fraction obtained by subjecting the periplasmic solution to S-Sepharose<sup>TM</sup> column chromatography and the finally purified IFN $\alpha$ -2b were subjected to SDS-PAGE according to the conventional method.

A nitrocellulose filter (Bio-Rad Lab, USA) was wetted with a buffer solution for blotting (170 mM glycine, 25 mM Tris · HCl [pH 8], 20% methanol) and the proteins separated on the gel were transferred onto the nitrocellulose filter over a period of 3 hours by using a blotting kit. The filter was kept in 1% Casein for 1 hour and washed three times with PBS containing 0.05% Tween<sup>TM</sup> 20. The filter was put in a rabbit anti-IFN $\alpha$  antibody (Chemicon, #AB1434, USA) solution diluted with PBS and reacted at room temperature for 2 hours. After reaction, the filter was washed 3 times with a PBST solution to remove unreacted antibody. Horseradish peroxidase-conjugated goat anti-rabbit IgG (Bio-Rad Lab., USA) diluted with PBS was added thereto and reacted at room temperature for 2 hour. The filter was washed with PBST, and a peroxidase substrate kit (Bio-Rad Lab., USA) solution was added thereto to develop a color reaction. The results from the above western blotting are shown in Fig. 5b, wherein lane 1 represents the periplasmic fraction of transformant *E.coli* HM 10711; lane 2, the fraction purified with S-Sepharose<sup>TM</sup> column chromatography; and lane 3, the final purified IFN $\alpha$ -2b.

As a result of Example, it is confirmed that a large quantity of soluble IFN $\alpha$  is expressed from the recombinant *E.coli* strains of the present invention.

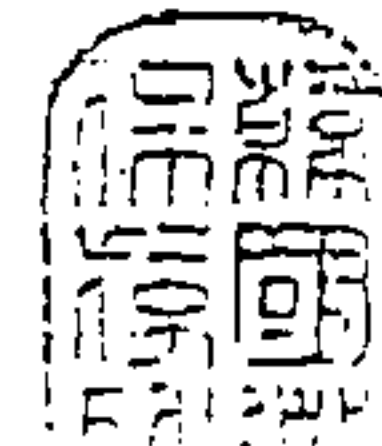

BUDAPEST TREATY ON THE INTERNATIONAL  
RECOGNITION OF THE DEPOSIT OF MICROORGANISMS  
FOR THE PURPOSES OF PATENT PROCEDURE

INTERNATIONAL FORM

To: Hanmi Pharm. Co., Ltd.  
893-5 Hajeo-ri Palsan-myun  
Hwasung-Kun  
Kyonggi-do,  
Republic of Korea

RECEIPT IN THE CASE OF AN ORIGINAL  
issued pursuant to Rule 7.1 by the  
INTERNATIONAL DEPOSITARY AUTHORITY  
identified at the bottom of this page

I. IDENTIFICATION OF THE MICROORGANISM	
Identification reference given by the DEPOSITOR :	Accession number given by the INTERNATIONAL DEPOSITARY AUTHORITY:
HM10503	KCCM-10175
II. SCIENTIFIC DESCRIPTION AND/OR PROPOSED TAXONOMIC DESIGNATION	
The microorganism identified under I above was accompanied by:	
<input type="checkbox"/> a scientific description <input type="checkbox"/> a proposed taxonomic designation (Mark with a cross where applicable)	
III. RECEIPT AND ACCEPTANCE	
This International Depositary Authority accepts the microorganism identified under I above, which was received by it on Dec. 23, 1999 (date of the original deposit) <sup>1</sup>	
IV. INTERNATIONAL DEPOSITARY AUTHORITY	
Name : Korean Culture Center of Microorganisms  Address : 361-221, Yurim B/D Hongje-1-dong, Seodaemun-gu SEOUL 120-091 Republic of Korea	Signature(s) of person(s) having the power to represent the International Depositary Authority of of authorized official(s):  Date: Dec. 29, 1999.

<sup>1</sup> Where Rule 6.4(d) applies, such date is the date on which the status of international depositary authority was acquired; where a deposit made outside the Budapest Treaty after the acquisition of the status of international depositary authority is converted into a deposit under the Budapest Treaty, such date is the date on which the microorganism was received by the international depositary authority.

WO 01/57217

PCT/KR01/00097

20

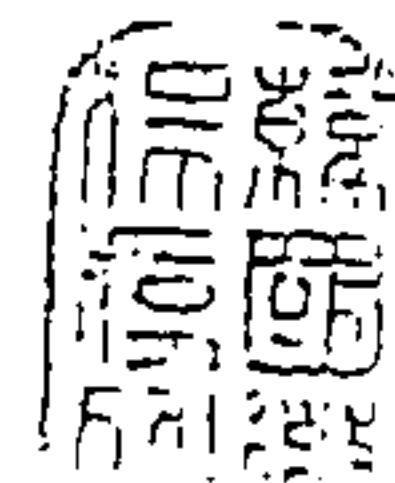

BUDAPEST TREATY ON THE INTERNATIONAL  
RECOGNITION OF THE DEPOSIT OF MICROORGANISMS  
FOR THE PURPOSES OF PATENT PROCEDURE

## INTERNATIONAL FORM

To: Hanni Pharm. Co., Ltd.  
898-5 Hajeon-ni Palan-myun  
Hwasung-Kun  
Kyonggi-do.  
Republic of Korea

RECEIPT IN THE CASE OF AN ORIGINAL  
issued pursuant to Rule 7.1 by the  
INTERNATIONAL DEPOSITARY AUTHORITY  
identified at the bottom of this page

I. IDENTIFICATION OF THE MICROORGANISM	
Identification reference given by the DEPOSITOR :	Accession number given by the INTERNATIONAL DEPOSITARY AUTHORITY:
JEMJ0611	KCCM-10176
II. SCIENTIFIC DESCRIPTION AND/OR PROPOSED TAXONOMIC DESIGNATION	
The microorganism identified under I above was accompanied by:	
<input type="checkbox"/> a scientific description <input type="checkbox"/> a proposed taxonomic designation (Mark with a cross where applicable)	
III. RECEIPT AND ACCEPTANCE	
This International Depositary Authority accepts the microorganism identified under I above, which was received by it on Dec. 23, 1999 (date of the original deposit) <sup>1</sup>	
IV. INTERNATIONAL DEPOSITARY AUTHORITY	
Name : Korean Culture Center of Microorganisms  Address : 361-221, Yunim E/D Hongje-1-dong, Seodaemun-gu SEOUL 120-091 Republic of Korea	Signature(s) of person(s) having the power to represent the International Depositary Authority of authorized official(s):  Date: Dec. 29, 1999.

<sup>1</sup> Where Rule 6.4(d) applies, such date is the date on which the status of international depositary authority was acquired; where a deposit made outside the Budapest Treaty after the acquisition of the status of international depositary authority is converted into a deposit under the Budapest Treaty, such date is the date on which the microorganism was received by the international depositary authority.



BUDAPEST TREATY ON THE INTERNATIONAL  
RECOGNITION OF THE DEPOSIT OF MICROORGANISMS  
FOR THE PURPOSES OF PATENT PROCEDURE

## INTERNATIONAL FORM

To: Hanmi Pharm. Co., Ltd.  
893-5 Hajeo-ri Palsan-myun  
Hwasong-Kun  
Kyonggi-do,  
Republic of Korea

RECEIPT IN THE CASE OF AN ORIGINAL  
issued pursuant to Rule 7.1 by the  
INTERNATIONAL DEPOSITARY AUTHORITY  
identified at the bottom of this page

I. IDENTIFICATION OF THE MICROORGANISM	
Identification reference given by the DEPOSITOR :	Accession number given by the INTERNATIONAL DEPOSITARY AUTHORITY :
HM10703	KCCM-10177
II. SCIENTIFIC DESCRIPTION AND/OR PROPOSED TAXONOMIC DESIGNATION	
The microorganism identified under I above was accompanied by:	
<input type="checkbox"/> a scientific description	
<input type="checkbox"/> a proposed taxonomic designation	
(Mark with a cross where applicable)	
III. RECEIPT AND ACCEPTANCE	
This International Depositary Authority accepts the microorganism identified under I above, which was received by it on Dec. 22, 1999 (date of the original deposit) <sup>1</sup>	
IV. INTERNATIONAL DEPOSITARY AUTHORITY	
Name : Korean Culture Center of Microorganisms  Address : 361-221, Yurim B/D Hongje-1-dong, Seodaemun-gu SEOUL 120-091 Republic of Korea	Signature(s) of person(s) having the power to represent the International Depositary Authority of authorized official(s) :  Date: Dec. 29, 1999.

<sup>1</sup> Where Rule 6.4(d) applies, such date is the date on which the status of international depositary authority was acquired ; where a deposit made outside the Budapest Treaty after the acquisition of the status of international depositary authority is converted into a deposit under the Budapest Treaty, such date is the date on which the microorganism was received by the international depositary authority.

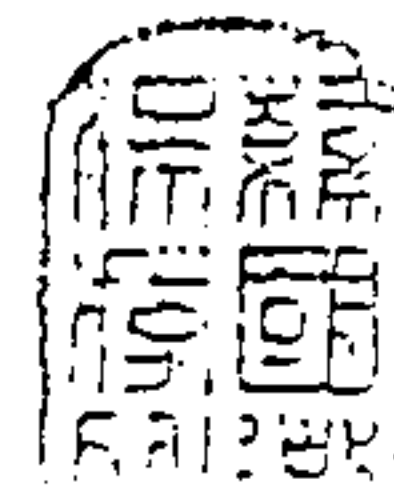

BUDAPEST TREATY ON THE INTERNATIONAL  
RECOGNITION OF THE DEPOSIT OF MICROORGANISMS  
FOR THE PURPOSES OF PATENT PROCEDURE

INTERNATIONAL FORM

To: Hannu Pharm. Co., Ltd.  
893-5 Hajeon-ri Paltan-myun  
Hwasung-Kun,  
Kyonggi-do,  
Republic of Korea

RECEIPT IN THE CASE OF AN ORIGINAL  
issued pursuant to Rule 7.1 by the  
INTERNATIONAL DEPOSITARY AUTHORITY  
identified at the bottom of this page

I. IDENTIFICATION OF THE MICROORGANISM	
Identification reference given by the DEPOSITOR :	Accession number given by the INTERNATIONAL DEPOSITARY AUTHORITY:
HM10711	KCCM-10178
II. SCIENTIFIC DESCRIPTION AND/OR PROPOSED TAXONOMIC DESIGNATION	
The microorganism identified under I above was accompanied by:	
<input type="checkbox"/> a scientific description <input type="checkbox"/> a proposed taxonomic designation (Mark with a cross where applicable)	
III. RECEIPT AND ACCEPTANCE	
This International Depositary Authority accepts the microorganism identified under I above, which was received by it on Dec. 23, 1999 (date of the original deposit) <sup>1</sup>	
IV. INTERNATIONAL DEPOSITARY AUTHORITY	
Name : Korean Culture Center of Microorganisms  Address : 361-221, Yurim B/D Hongje-1-dong, Seodaeun-gu SEOUL 120-091 Republic of Korea	Signature(s) of person(s) having the power to represent the International Depositary Authority of of authorized official(s):  Date: Dec. 29, 1999.



<sup>1</sup> Where Rule 6.4(d) applies, such date is the date on which the status of international depositary authority was acquired; where a deposit made outside the Budapest Treaty after the acquisition of the status of international depositary authority is converted into a deposit under the Budapest Treaty, such date is the date on which the microorganism was received by the international depositary authority.

## SEQUENCE LISTING

## (1) GENERAL INFORMATION

(i) APPLICANT: Hanmi Pharm. Co., Ltd.  
895-5, Hajeo-rai, Paltanmyeon,  
Hwaseong-gun, Kyungki-do 445-910 (KR)

(ii) TITLE OF INVENTION: EXPRESSION AND SECRETION VECTOR FOR HUMAN  
INTERFERON ALPHA AND PROCESS FOR PRODUCING HUMAN INTERFERON ALPHA BY EMPLOYING  
SAME

(iii) NUMBER OF SEQUENCES: 34

## (iv) CORRESPONDENCE ADDRESS:

(A) ADDRESSEE: CASSAN MACLEAN  
(B) STREET: Suite 401 - 80 Aberdeen Street  
(C) CITY: Ottawa  
(D) PROVINCE: Ontario  
(E) COUNTRY: Canada  
(F) POSTAL CODE: K1S 5R5

## (v) COMPUTER READABLE FORM:

(A) MEDIUM TYPE: Floppy disc  
(B) COMPUTER: IBM PC compatible  
(C) OPERATING SYSTEM: PC-DOS/MS-DOS  
(D) SOFTWARE: KopatentIn 1.71

## (vi) CURRENT APPLICATION DATA:

(A) APPLICATION NUMBER: 2,397,527  
(B) FILING DATE: January 19, 2001  
(C) CLASSIFICATION:

## (vii) PRIOR APPLICATION DATA:

(A) APPLICATION NUMBER: PCT/KR01/00097  
(B) FILING DATE: January 19, 2001  
(C) CLASSIFICATION:

## (vii) PRIOR APPLICATION DATA:

(A) APPLICATION NUMBER: 2000-2434  
(B) FILING DATE: January 19, 2000  
(C) CLASSIFICATION:

## (viii) ATTORNEY/AGENT INFORMATION:

(A) NAME: MACLEAN, P. Scott  
(B) REGISTRATION NUMBER:  
(C) REFERENCE/DOCKET NUMBER: 37543-0090

## (ix) TELECOMMUNICATION INFORMATION:

(A) TELEPHONE: (613) 238-6404  
(B) TELEFAX: (613) 230-8755

## (2) INFORMATION FOR SEQ ID NO. 1:

## (i) SEQUENCE CHARACTERISTICS:

(A) LENGTH: 165  
(B) TYPE: PRT

(vi) ORIGINAL SOURCE: Homo sapiens

(ix) FEATURE:

## (D) OTHER INFORMATION: primer

## (xi) SEQUENCE DESCRIPTION: SEQ ID NO. 1:

Cys Asp Leu Pro Glu Thr His Ser Leu Gly Ser Arg Arg Thr Leu Met  
 1 5 10 15  
 Leu Leu Ala Gln Met Arg Lys Ile Ser Leu Phe Ser Cys Leu Lys Asp  
 20 25 30  
 Arg Arg Asp Phe Gly Phe Pro Gln Glu Glu Phe Gly Asn Gln Phe Gln  
 35 40 45  
 Lys Ala Glu Thr Ile Pro Val Leu His Glu Met Ile Gln Gln Ile Phe  
 50 55 60  
 Asn Leu Phe Ser Thr Lys Asp Ser Ser Ala Ala Trp Asp Glu Thr Leu  
 65 70 75 80  
 Leu Asp Lys Phe Tyr Thr Glu Leu Tyr Gln Gln Leu Asn Asp Leu Glu  
 85 90 95  
 Ala Cys Val Ile Gln Gly Val Gly Val Thr Glu Thr Pro Leu Met Lys  
 100 105 110  
 Glu Asp Ser Ile Leu Ala Val Arg Lys Tyr Phe Gln Arg Ile Thr Leu  
 115 120 125  
 Tyr Leu Lys Glu Lys Lys Tyr Ser Pro Cys Ala Trp Glu Val Val Arg  
 130 135 140  
 Ala Glu Ile Met Arg Ser Phe Ser Leu Ser Thr Asn Leu Gln Glu Ser  
 145 150 155 160  
 Leu Arg Ser Lys Glu  
 165

## (3) INFORMATION FOR SEQ ID NO. 2:

## (i) SEQUENCE CHARACTERISTICS:

(A) LENGTH: 165

(B) TYPE: PRT

## (vi) ORIGINAL SOURCE: Homo sapiens

## (xi) SEQUENCE DESCRIPTION: SEQ ID NO. 2:

Cys Asp Leu Pro Glu Thr His Ser Leu Gly Ser Arg Arg Thr Leu Met  
 1 5 10 15  
 Leu Leu Ala Gln Met Arg Arg Ile Ser Leu Phe Ser Cys Leu Lys Asp  
 20 25 30  
 Arg Arg Asp Phe Gly Phe Pro Gln Glu Glu Phe Gly Asn Gln Phe Gln  
 35 40 45  
 Lys Ala Glu Thr Ile Pro Val Leu His Glu Met Ile Gln Gln Ile Phe  
 50 55 60



(A) LENGTH: 69  
(B) TYPE: DNA

(vi) ORIGINAL SOURCE: Artificial Sequence

(ix) FEATURE:

(D) OTHER INFORMATION: DNA encoding a modified E. coli  
thermostable enterotoxin II ([Thr4, Gln22] ST II)

(xi) SEQUENCE DESCRIPTION: SEQ ID NO. 5:

atgaaaaaga caatcgcatt tcttcttgca tctatgttcg ttttttctat tgctacaaat 60  
gccaagcg 69

(7) INFORMATION FOR SEQ ID NO. 6:

(i) SEQUENCE CHARACTERISTICS:

(A) LENGTH: 69  
(B) TYPE: DNA

(vi) ORIGINAL SOURCE: Artificial Sequence

(ix) FEATURE:

(D) OTHER INFORMATION: DNA encoding a modified E. coli  
thermostable enterotoxin II ([Thr4, Val20, Gln22] ST II)

(xi) SEQUENCE DESCRIPTION: SEQ ID NO. 6:

atgaaaaaga caatcgcatt tcttcttgca tctatgttcg ttttttctat tgctacagtt 60  
gccaagcg 69

(8) INFORMATION FOR SEQ ID NO. 7:

(i) SEQUENCE CHARACTERISTICS:

(A) LENGTH: 69  
(B) TYPE: DNA

(vi) ORIGINAL SOURCE: Artificial Sequence

(ix) FEATURE:

(D) OTHER INFORMATION: DNA encoding a modified E. coli  
thermostable enterotoxin II ([Thr4, Val20] ST II)

(xi) SEQUENCE DESCRIPTION: SEQ ID NO. 7:

atgaaaaaga caatcgcatt tcttcttgca tctatgttcg ttttttctat tgctacagtt 60  
gcctacgcg 69

(9) INFORMATION FOR SEQ ID NO. 8:

(i) SEQUENCE CHARACTERISTICS:

(A) LENGTH: 11  
(B) TYPE: DNA

(vi) ORIGINAL SOURCE: Escherichia coli

(xi) SEQUENCE DESCRIPTION: SEQ ID NO. 8:

gaggtgattt t

11

## (10) INFORMATION FOR SEQ ID NO. 9:

## (i) SEQUENCE CHARACTERISTICS:

(A) LENGTH: 10

(B) TYPE: DNA

(vi) ORIGINAL SOURCE: Artificial Sequence

## (ix) FEATURE:

(D) OTHER INFORMATION: Modified Shine-Dalgarno sequence of E. coli thermostable enterotoxin II

(xi) SEQUENCE DESCRIPTION: SEQ ID NO. 9:

gaggtgtttt

10

## (11) INFORMATION FOR SEQ ID NO. 10:

## (i) SEQUENCE CHARACTERISTICS:

(A) LENGTH: 35

(B) TYPE: DNA

(vi) ORIGINAL SOURCE: Artificial Sequence

## (ix) FEATURE:

(D) OTHER INFORMATION: primer for preparing the N-terminal of interferon alpha-2a

(xi) SEQUENCE DESCRIPTION: SEQ ID NO. 10:

cgccgccata tgtgtgatct gcctcaaacc cacag

35

## (12) INFORMATION FOR SEQ ID NO. 11:

## (i) SEQUENCE CHARACTERISTICS:

(A) LENGTH: 36

(B) TYPE: DNA

(vi) ORIGINAL SOURCE: Artificial Sequence

## (ix) FEATURE:

(D) OTHER INFORMATION: primer for preparing the C-terminal of interferon alpha-2a

(xi) SEQUENCE DESCRIPTION: SEQ ID NO. 11:

accgaattcg gatcctcatt ccttacttct taaact

36

## (13) INFORMATION FOR SEQ ID NO. 12:

## (i) SEQUENCE CHARACTERISTICS:

(A) LENGTH: 72

(B) TYPE: DNA

(vi) ORIGINAL SOURCE: Artificial Sequence

(ix) FEATURE:

(D) OTHER INFORMATION: primer for the preparation of the secretion sequence of E. coli thermostable enterotoxin II

(xi) SEQUENCE DESCRIPTION: SEQ ID NO. 12:

tcatgaaaaa gaatatcgca tttcttcttg catctatggt cgttttttct attgctacaa 60  
atgcctacgc gt 72

(14) INFORMATION FOR SEQ ID NO. 13:

(i) SEQUENCE CHARACTERISTICS:

(A) LENGTH: 72

(B) TYPE: DNA

(vi) ORIGINAL SOURCE: Artificial Sequence

(ix) FEATURE:

(D) OTHER INFORMATION: primer for the preparation of the secretion sequence of E. coli thermostable enterotoxin II

(xi) SEQUENCE DESCRIPTION: SEQ ID NO. 13:

acgcgtaggc attttagca atagaaaaaa cgaacataga tgcaagaaga aatgcgatat 60  
tctttttcat ga 72

(15) INFORMATION FOR SEQ ID NO. 14:

(i) SEQUENCE CHARACTERISTICS:

(A) LENGTH: 38

(B) TYPE: DNA

(vi) ORIGINAL SOURCE: Artificial Sequence

(ix) FEATURE:

(D) OTHER INFORMATION: primer for preparing the N-terminal of interferon alpha-2a

(xi) SEQUENCE DESCRIPTION: SEQ ID NO. 14:

acaaatgcct acgcgtgtga tctgcctcaa acccacag 38

(16) INFORMATION FOR SEQ ID NO. 15:

(i) SEQUENCE CHARACTERISTICS:

(A) LENGTH: 36

(B) TYPE: DNA

(vi) ORIGINAL SOURCE: Artificial Sequence

(ix) FEATURE:

(D) OTHER INFORMATION: primer for preparing the C-terminal of interferon alpha-2a

## (xi) SEQUENCE DESCRIPTION: SEQ ID NO. 15:

accgaattcg gatcctcatt ccttacttct taaact

36

## (17) INFORMATION FOR SEQ ID NO. 16:

## (i) SEQUENCE CHARACTERISTICS:

- (A) LENGTH: 65
- (B) TYPE: DNA

(vi) ORIGINAL SOURCE: Artificial Sequence

## (ix) FEATURE:

(D) OTHER INFORMATION: primer for introducing Shine-Dalgarno sequence of E. coli ST II

## (xi) SEQUENCE DESCRIPTION: SEQ ID NO. 16:

cggtttcct ctagaggttg aggtgttta tgaaaagaa tatcgcattt cttcttgcac  
ctatg 65

60

## (18) INFORMATION FOR SEQ ID NO. 17:

## (i) SEQUENCE CHARACTERISTICS:

- (A) LENGTH: 36
- (B) TYPE: DNA

(vi) ORIGINAL SOURCE: Artificial Sequence

## (ix) FEATURE:

(D) OTHER INFORMATION: primer for introducing Shine-Dalgarno sequence of E. coli ST II

## (xi) SEQUENCE DESCRIPTION: SEQ ID NO. 17:

accgaattcg gatcctcatt ccttacttct taaact

36

## (19) INFORMATION FOR SEQ ID NO. 18:

## (i) SEQUENCE CHARACTERISTICS:

- (A) LENGTH: 13
- (B) TYPE: PRT

(vi) ORIGINAL SOURCE: Escherichia coli

## (xi) SEQUENCE DESCRIPTION: SEQ ID NO. 18:

Leu Leu Ala Gln Met Arg Arg Ile Ser Leu Phe Ser Cys  
1 5 10

## (20) INFORMATION FOR SEQ ID NO. 19:

## (i) SEQUENCE CHARACTERISTICS:

- (A) LENGTH: 39
- (B) TYPE: DNA

(vi) ORIGINAL SOURCE: Artificial Sequence

(ix) FEATURE:

(D) OTHER INFORMATION: oligonucleotide for preparing interferon  
alpha-2b

(xi) SEQUENCE DESCRIPTION: SEQ ID NO. 19:

ctcctggcac agatgaggag aatctctctt ttctcctgc 39

(21) INFORMATION FOR SEQ ID NO. 20:

(i) SEQUENCE CHARACTERISTICS:

(A) LENGTH: 39

(B) TYPE: DNA

(vi) ORIGINAL SOURCE: Artificial Sequence

(ix) FEATURE:

(D) OTHER INFORMATION: anti-sense of SEQ ID NO: 19

(xi) SEQUENCE DESCRIPTION: SEQ ID NO. ~~20~~

gaggaccgtg tctactctc ttagagagaa aagaggacg 39

(22) INFORMATION FOR SEQ ID NO. 21:

(i) SEQUENCE CHARACTERISTICS:

(A) LENGTH: 8

(B) TYPE: PRT

(vi) ORIGINAL SOURCE: Artificial Sequence

(ix) FEATURE:

(D) OTHER INFORMATION: 1st to 8th amino acids of [Thr4] ST II

(xi) SEQUENCE DESCRIPTION: SEQ ID NO. 21:

Met Lys Lys Thr Ile Ala Phe Leu  
1 5

(23) INFORMATION FOR SEQ ID NO. 22:

(i) SEQUENCE CHARACTERISTICS:

(A) LENGTH: 34

(B) TYPE: DNA

(vi) ORIGINAL SOURCE: Artificial Sequence

(ix) FEATURE:

(D) OTHER INFORMATION: oligonucleotide for preparing [Thr4] ST  
II

(xi) SEQUENCE DESCRIPTION: SEQ ID NO. 22:

ggtgatttta tgaaaaagac aatcgattt cttc 34

## (24) INFORMATION FOR SEQ ID NO. 23:

## (i) SEQUENCE CHARACTERISTICS:

- (A) LENGTH: 34
- (B) TYPE: DNA

(vi) ORIGINAL SOURCE: Artificial Sequence

## (ix) FEATURE:

- (D) OTHER INFORMATION: anti-sense of SEQ ID NO: 22

(xi) SEQUENCE DESCRIPTION: SEQ ID NO. 23:

gaagaaatgc gattgtcttt ttcataaaat cacc

34

## (25) INFORMATION FOR SEQ ID NO. 24:

## (i) SEQUENCE CHARACTERISTICS:

- (A) LENGTH: 11
- (B) TYPE: PRT

(vi) ORIGINAL SOURCE: Artificial Sequence

## (ix) FEATURE:

- (D) OTHER INFORMATION: 20th to 27th amino acids of [Gln22] ST II

(xi) SEQUENCE DESCRIPTION: SEQ ID NO. 24:

Asn	Ala	Gln	Ala	Cys	Asp	Leu	Pro	Gln	Thr	His
1			5				10			

## (26) INFORMATION FOR SEQ ID NO. 25:

## (i) SEQUENCE CHARACTERISTICS:

- (A) LENGTH: 37
- (B) TYPE: DNA

(vi) ORIGINAL SOURCE: Artificial Sequence

## (ix) FEATURE:

- (D) OTHER INFORMATION: oligonucleotide for preparing [Gln22] ST

II

(xi) SEQUENCE DESCRIPTION: SEQ ID NO. 25:

caaatgccca agcgtgtgat ctgcctcaaa cccacag

37

## (27) INFORMATION FOR SEQ ID NO. 26:

## (i) SEQUENCE CHARACTERISTICS:

- (A) LENGTH: 37
- (B) TYPE: DNA

(vi) ORIGINAL SOURCE: Artificial Sequence

## (ix) FEATURE:

(D) OTHER INFORMATION: anti-sense of SEQ ID NO: 25

(xi) SEQUENCE DESCRIPTION: SEQ ID NO. 26:

ctgtggggtt gaggcagatc acacgcttgg gcatttg

37

(28) INFORMATION FOR SEQ ID NO. 27:

(i) SEQUENCE CHARACTERISTICS:

(A) LENGTH: 24

(B) TYPE: DNA

(vi) ORIGINAL SOURCE: Artificial Sequence

(ix) FEATURE:

(D) OTHER INFORMATION: primer for preparing the modified Shine-Dalgarno sequence of SEQ ID NO: 9

(xi) SEQUENCE DESCRIPTION: SEQ ID NO. 27:

tctagagggtt gaggtgtttt atga

24

(29) INFORMATION FOR SEQ ID NO. 28:

(i) SEQUENCE CHARACTERISTICS:

(A) LENGTH: 24

(B) TYPE: DNA

(vi) ORIGINAL SOURCE: Artificial Sequence

(ix) FEATURE:

(D) OTHER INFORMATION: anti-sense of SEQ ID NO: 27

(xi) SEQUENCE DESCRIPTION: SEQ ID NO. 28:

tcataaaaaca cctcaacctc taga

24

(30) INFORMATION FOR SEQ ID NO. 29:

(i) SEQUENCE CHARACTERISTICS:

(A) LENGTH: 42

(B) TYPE: DNA

(vi) ORIGINAL SOURCE: Artificial Sequence

(ix) FEATURE:

(D) OTHER INFORMATION: oligonucleotide for preparing [Val20] ST

II

(xi) SEQUENCE DESCRIPTION: SEQ ID NO. 29:

gttttttcta ttgctacagt tgcccaagcg tgtgatctgc ct

42

(31) INFORMATION FOR SEQ ID NO. 30:

(i) SEQUENCE CHARACTERISTICS:

(A) LENGTH: 42  
(B) TYPE: DNA

(vi) ORIGINAL SOURCE: Artificial Sequence

(ix) FEATURE:

(D) OTHER INFORMATION: anti-sense of SEQ ID NO: 29

(xi) SEQUENCE DESCRIPTION: SEQ ID NO. 30:

aggcagatca cacgcttggg caactgtagc aatagaaaaa ac 42

(32) INFORMATION FOR SEQ ID NO. 31:

(i) SEQUENCE CHARACTERISTICS:

(A) LENGTH: 25  
(B) TYPE: DNA

(vi) ORIGINAL SOURCE: Artificial Sequence

(ix) FEATURE:

(D) OTHER INFORMATION: primer for preparing a modified Shine-Dalgarno sequence

(xi) SEQUENCE DESCRIPTION: SEQ ID NO. 31:

tctagagggtt gaggttttta tgaaa 25

(33) INFORMATION FOR SEQ ID NO. 32:

(i) SEQUENCE CHARACTERISTICS:

(A) LENGTH: 25  
(B) TYPE: DNA

(vi) ORIGINAL SOURCE: Artificial Sequence

(ix) FEATURE:

(D) OTHER INFORMATION: anti-sense of SEQ ID NO: 31

(xi) SEQUENCE DESCRIPTION: SEQ ID NO. 32:

tttcataaaa acctcaacct ctaga 25

(34) INFORMATION FOR SEQ ID NO. 33:

(i) SEQUENCE CHARACTERISTICS:

(A) LENGTH: 24  
(B) TYPE: DNA

(vi) ORIGINAL SOURCE: Artificial Sequence

(ix) FEATURE:

(D) OTHER INFORMATION: primer for preparing a modified Shine-Dalgarno sequence

(xi) SEQUENCE DESCRIPTION: SEQ ID NO. 33:

tctagagggtt gaggttttat gaaa

24

(35) INFORMATION FOR SEQ ID NO. 34:

(i) SEQUENCE CHARACTERISTICS:

(A) LENGTH: 24

(B) TYPE: DNA

(vi) ORIGINAL SOURCE: Artificial Sequence

(ix) FEATURE:

(D) OTHER INFORMATION: anti-sense of SEQ ID NO: 33

(xi) SEQUENCE DESCRIPTION: SEQ ID NO. 34:

tttcataaaa cctcaacctc taga

24

What is claimed is:

1. An expression vector for the secretive production of human interferon alpha (hIFN $\alpha$ ) comprising a polynucleotide encoding a modified thermostable enterotoxin II signal sequence and a polynucleotide encoding hIFN $\alpha$  ligated to the 3'-end thereof, wherein the modified thermostable enterotoxin II signal sequence is selected from the group consisting of:

a polypeptide obtained by replacing the 4<sup>th</sup> asparagine of the amino acid sequence of SEQ ID NO: 3 with threonine, and

a polypeptide obtained by replacing the 4<sup>th</sup> and 20<sup>th</sup> asparagines of the amino acid sequence of SEQ ID NO: 3 with threonine and valine, respectively.

2. The expression vector according to claim 1, wherein the polynucleotide encoding hIFN $\alpha$  codes for IFN $\alpha$ -2a of SEQ ID NO: 1 or IFN $\alpha$ -2b of SEQ ID NO:

2.

3. The expression vector according to claim 1, which further comprises *E. coli* thermostable enterotoxin II Shine-Dalgarno sequence (SD sequence, SEQ ID NO: 8) or a mutant thereof ligated to the front of the 5'-end of the polynucleotide encoding the modified thermostable enterotoxin II signal sequence, wherein the mutant has the nucleotide sequence of SEQ ID NO: 9.

4. The expression vector according to claim 1, which is selected from the group consisting of plasmids pT14SSl $\alpha$ -2a-4T, pT14OSSl $\alpha$ -2a-4T, pT14SSl $\alpha$ -2b-4T and pT14OSSl $\alpha$ -2b-4T.

5. An *E. coli* transformed with the expression vector of any one of claims 1 to 4.
6. The microorganism according to claim 5, which is selected from the group consisting of *E. coli* BL21(DE3)/pT14SS1 $\alpha$ -2a-4T (HM 10602); *E. coli* BL21(DE3)/pT14OSS1 $\alpha$ -2a-4T (HM10603; Accession No. KCCM-10175); *E. coli* BL21(DE3)/pT14SS1 $\alpha$ -2b-4T (HM10702); and *E. coli* BL21(DE3)/pT14OSS1 $\alpha$ -2b-4T (HM10703; Accession No. KCCM-10177).
7. A process for secretively producing hIFN $\alpha$  having no additional methionine residue attached at the N-terminal comprising the steps of:
  - transforming an *E. coli* with an expression vector for the secretive production hIFN $\alpha$  comprising a polynucleotide encoding a modified thermostable enterotoxin II signal sequence and a polynucleotide encoding hIFN $\alpha$  ligated to the 3'-end thereof; and culturing the transformed *E. coli*,
  - wherein the modified thermostable enterotoxin II signal sequence is selected from the group consisting of:
    - a polypeptide obtained by replacing the 4<sup>th</sup> asparagine of the amino acid sequence of SEQ ID NO: 3 with threonine, and
    - a polypeptide obtained by replacing the 4<sup>th</sup> and 20<sup>th</sup> asparagines of the amino acid sequence of SEQ ID NO: 3 with threonine and valine, respectively.
8. The process according to claim 7, wherein the polynucleotide encoding hIFN $\alpha$  codes for IFN $\alpha$ -2a of SEQ ID NO: 1 or IFN  $\alpha$ -2b of SEQ ID NO: 2.

9. The process according to claim 7, wherein the vector further comprises *E. coli* thermostable enterotoxin II SD sequence (SEQ ID NO: 8) or a mutant thereof ligated to the front of the 5'-end of the polynucleotide encoding the modified thermostable enterotoxin II signal sequence, wherein the mutant has the nucleotide sequence of SEQ ID NO: 9.
10. The process according to claim 7, wherein the expression vector is selected from the group consisting of plasmids pT14SSl $\alpha$ -2a-4T, pT14OSSl $\alpha$ -2a-4T, pT14SSl $\alpha$ -2b-4T and pT14OSSl  $\alpha$ -2b-4T.
11. The process according to claim 7, wherein the transformed microorganism is selected from the group consisting of *E. coli* BL21(DE3)/pT14SSl $\alpha$ -2a-4T (HM 10602); *E. coli* BL21(DE3)/pT14OSSl $\alpha$ -2a-4T (HM10603; Accession No. KCCM-10175); *E. coli* BL21(DE3)/pT14SSl $\alpha$ -2b-4T (HM10702); and *E. coli* BL21(DE3)/pT14OSSl $\alpha$ -2b-4T (HM10703; Accession No. KCCM-10177).

1/5  
FIG. 1

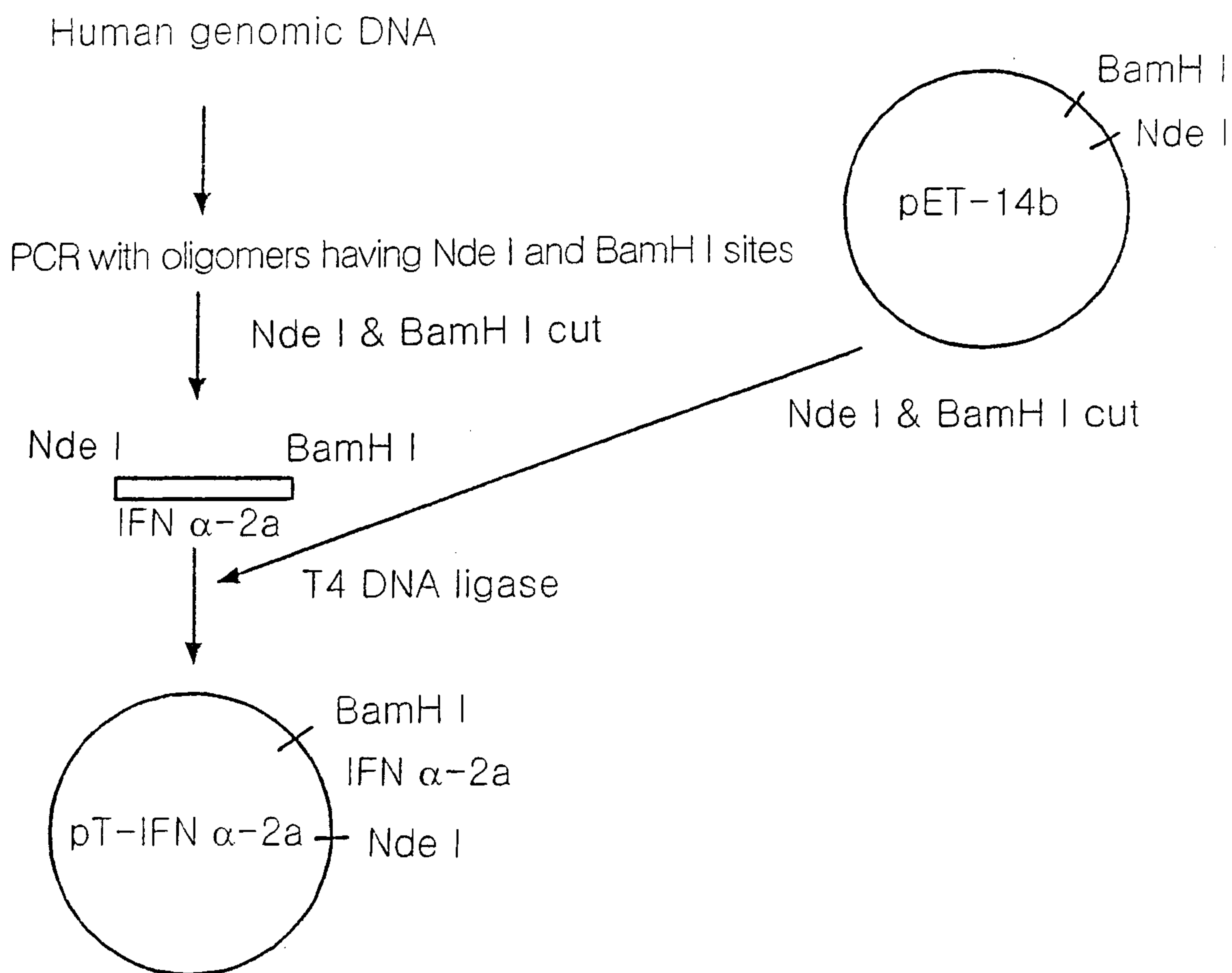
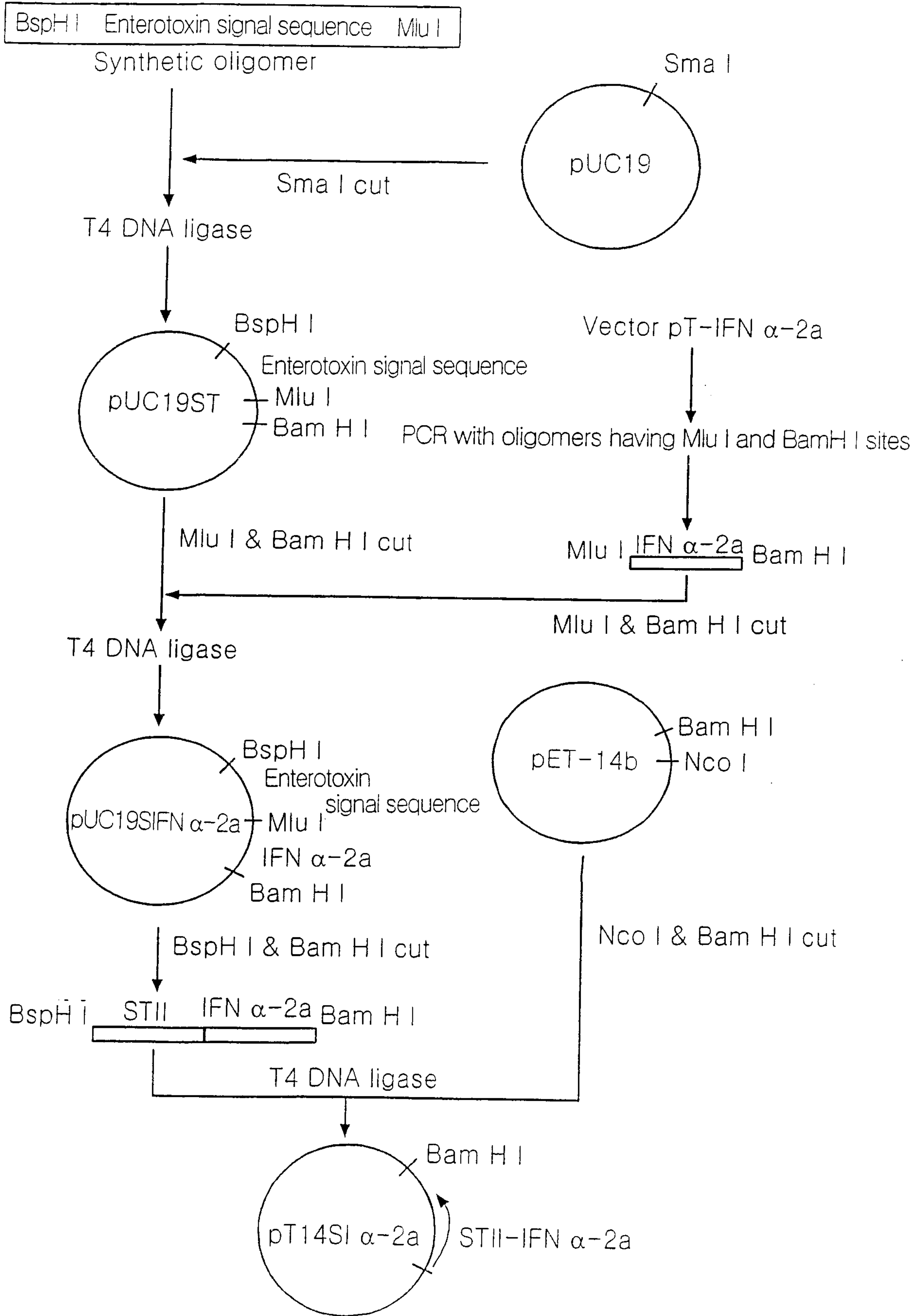
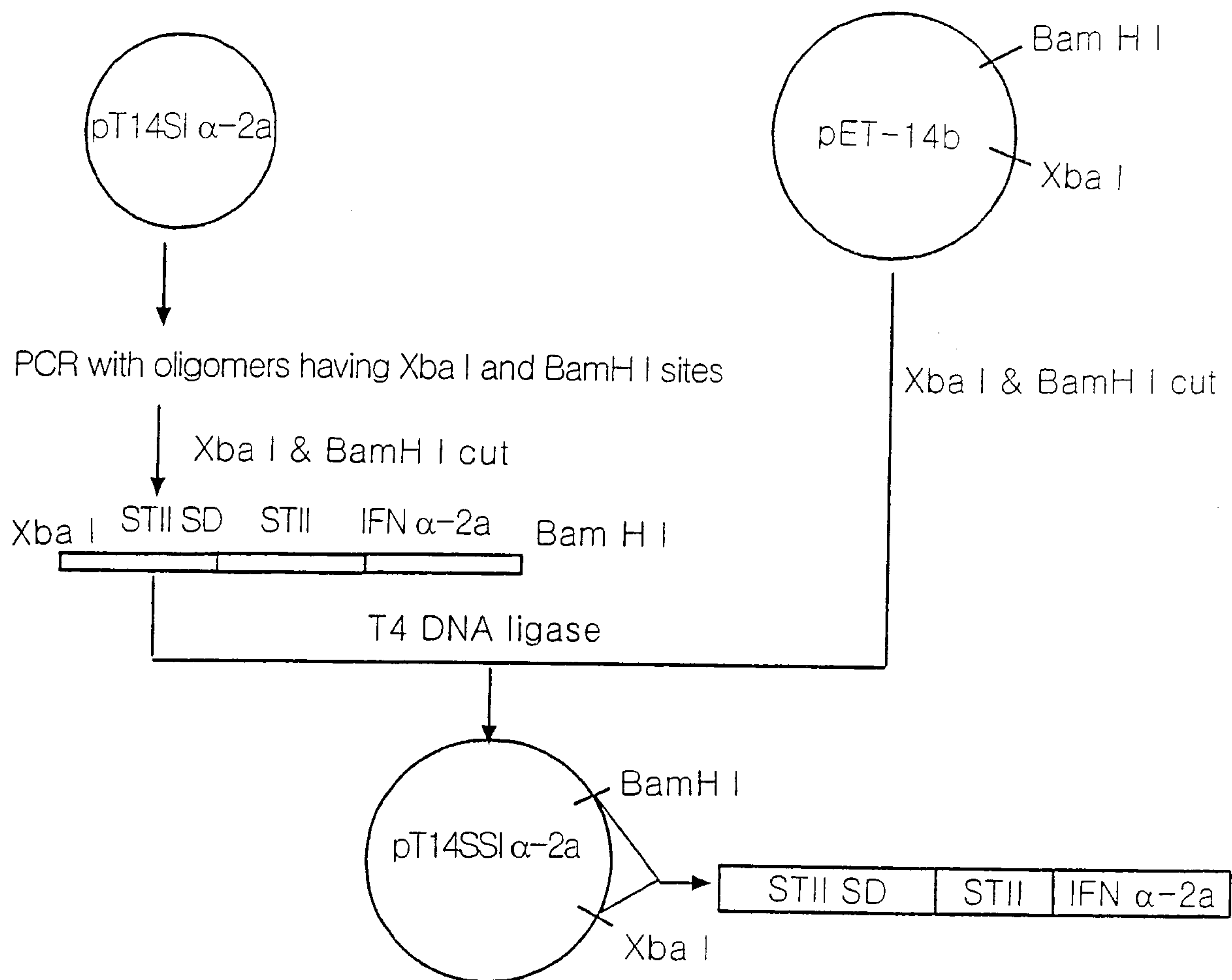

FIG. 2



3/5  
FIG. 3

4/5

FIG. 4

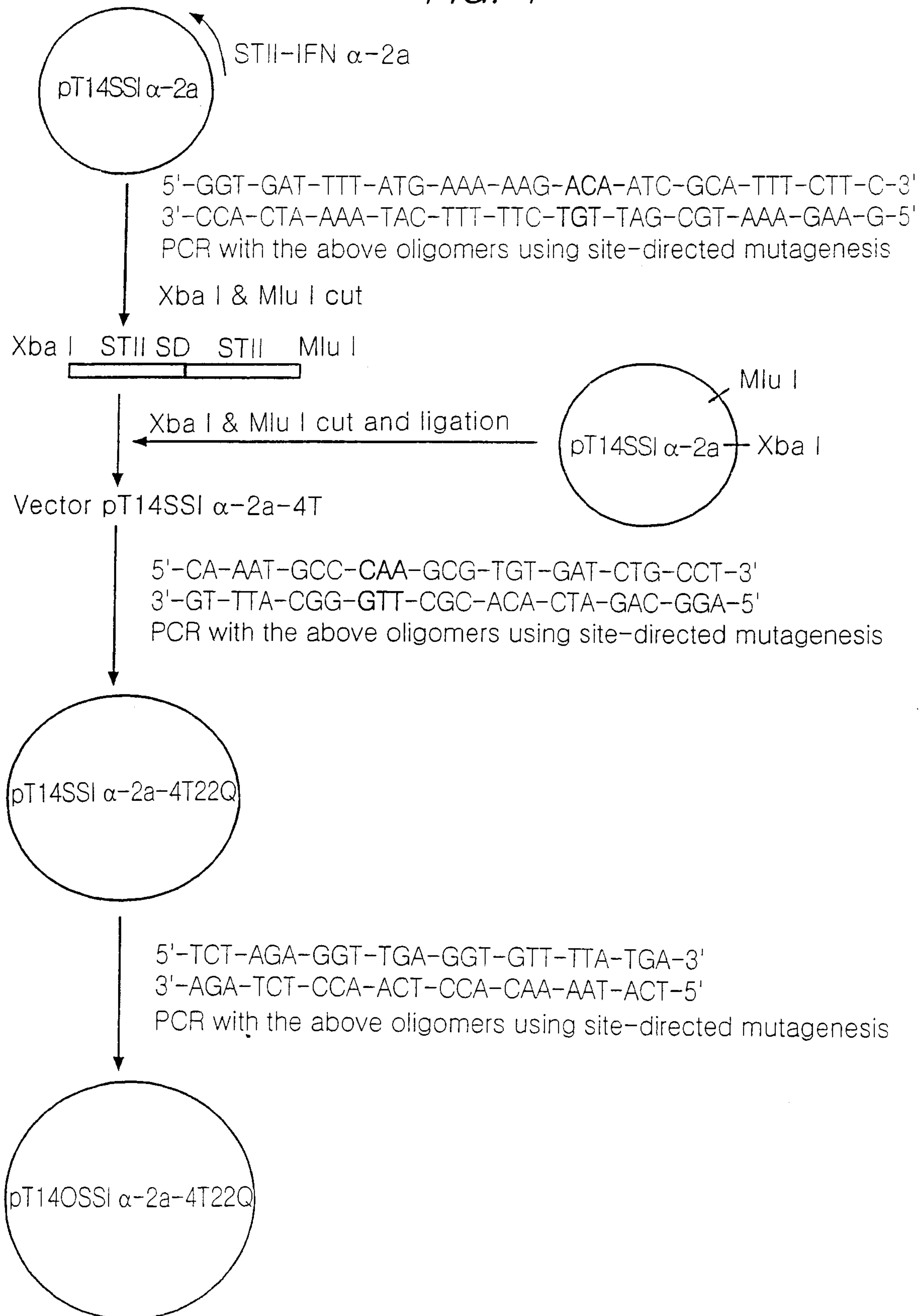

5/5

FIG. 5A

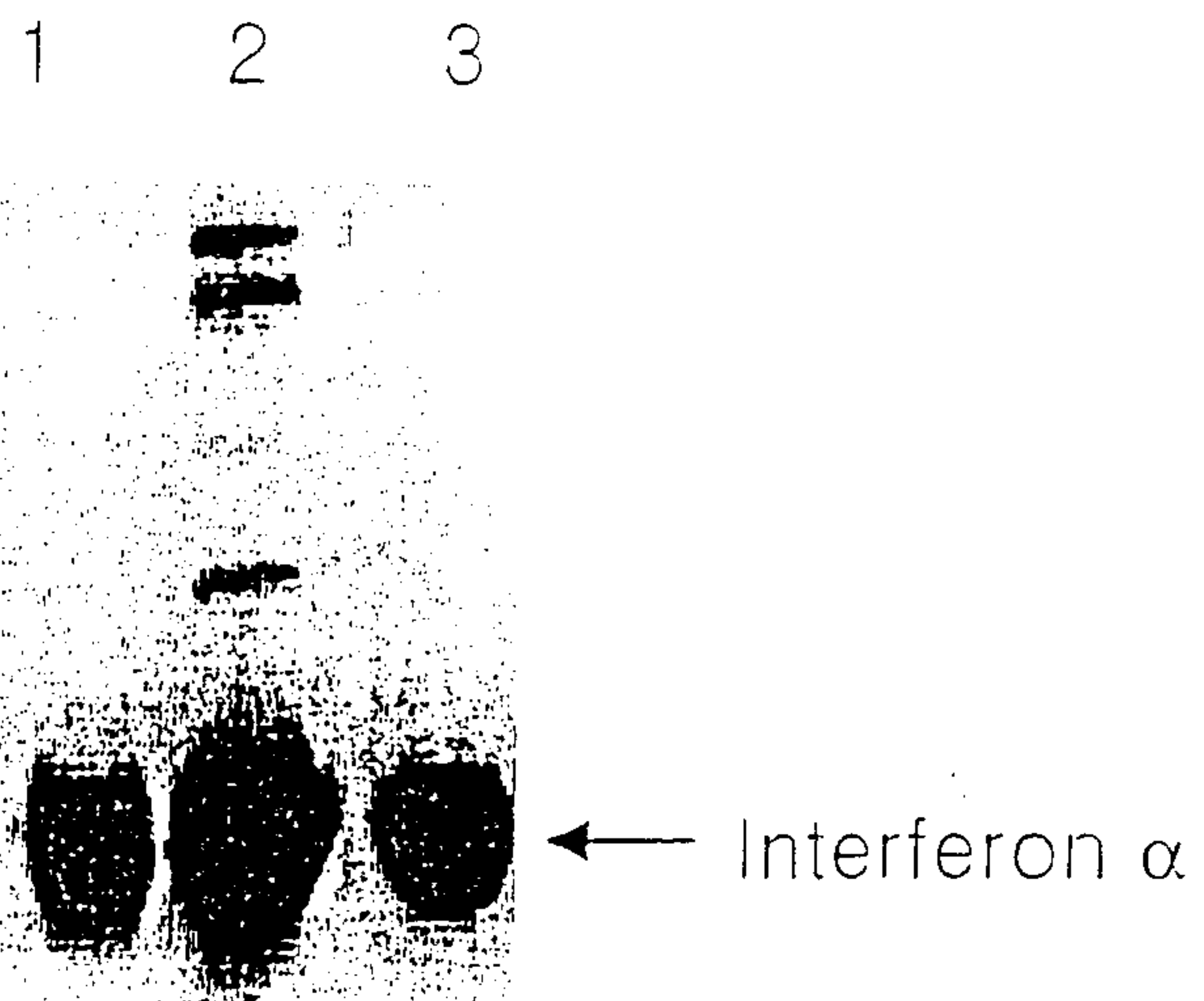
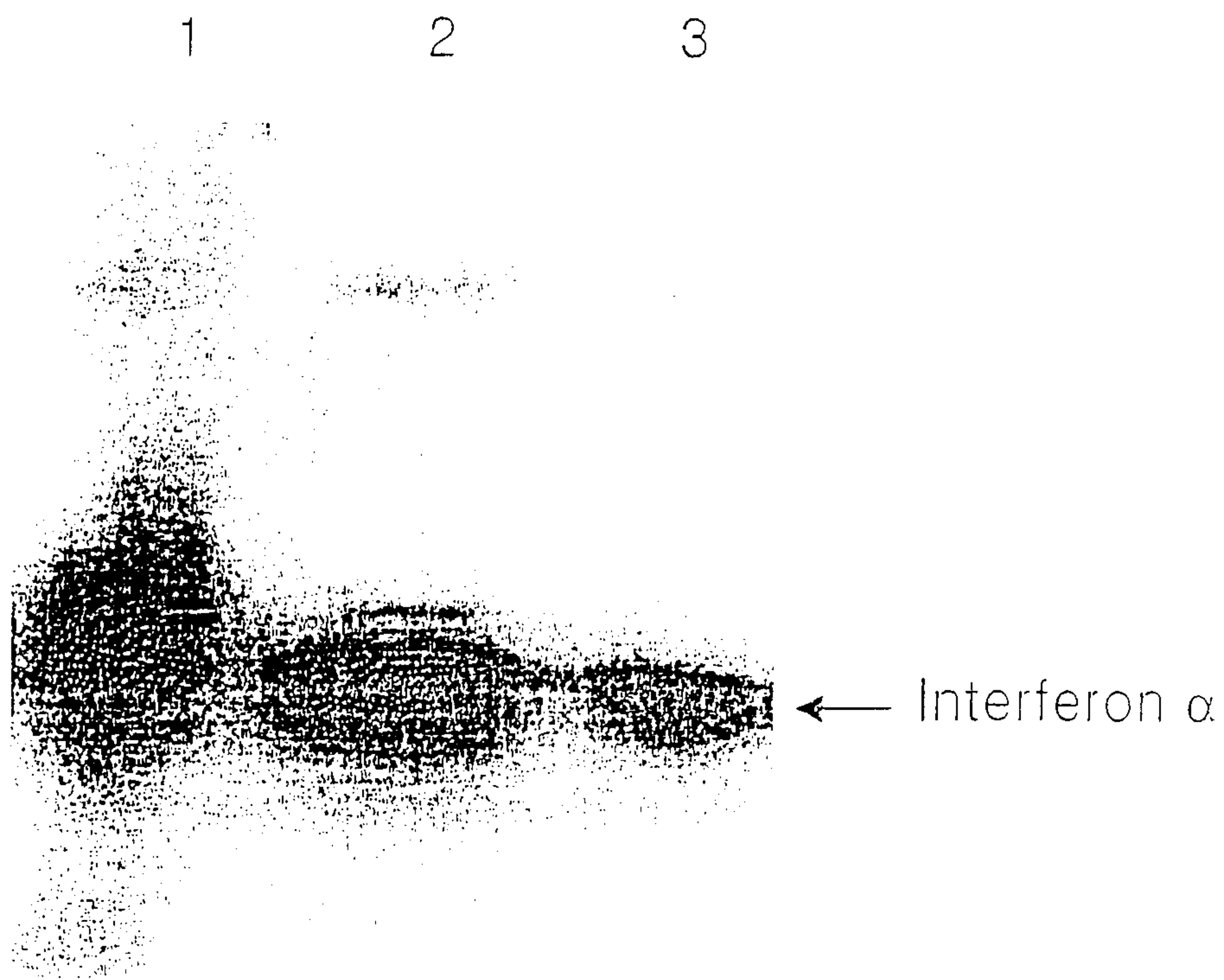

FIG. 5B



1

2

3

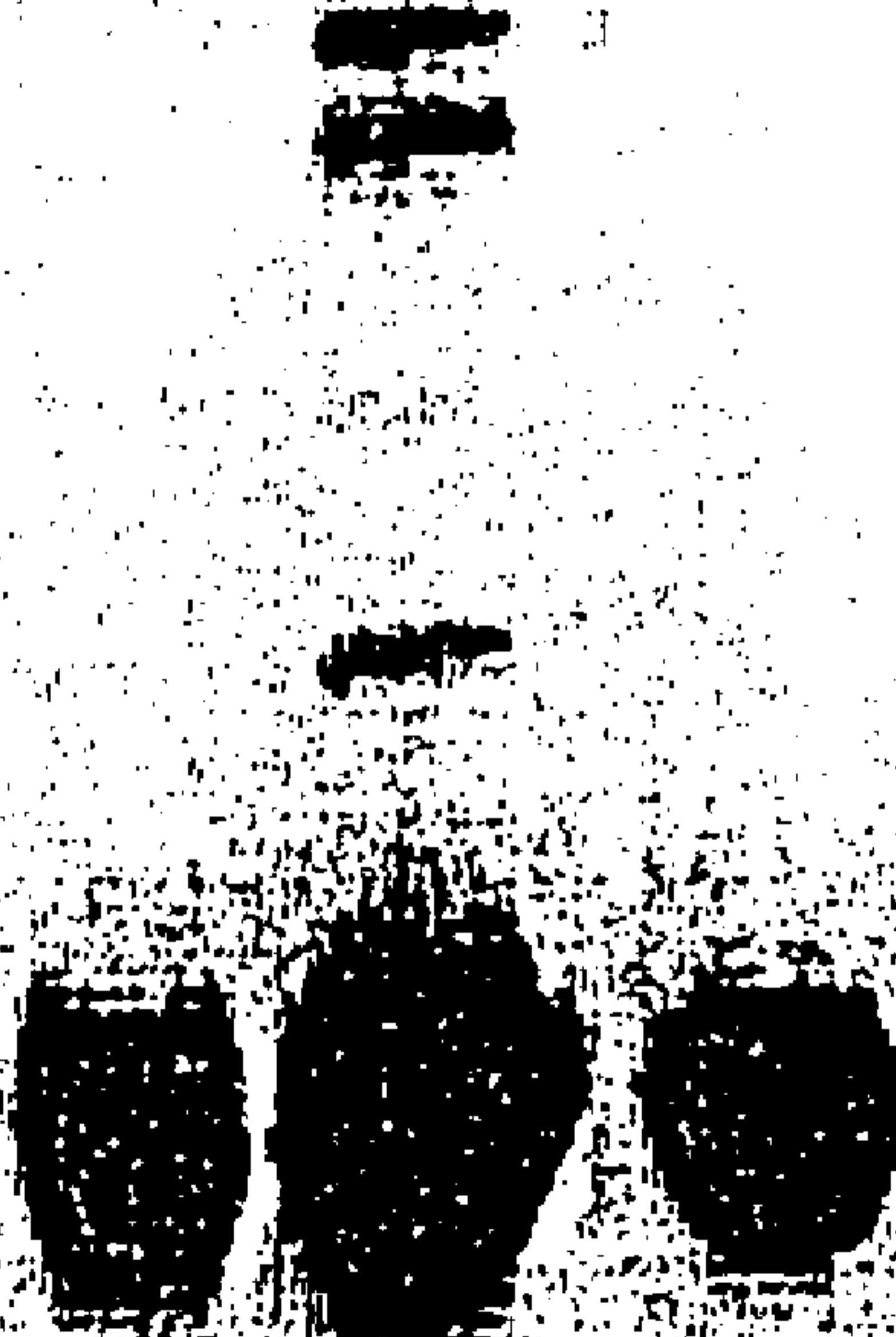

Interferon  $\alpha$