

(19) World Intellectual Property Organization
International Bureau



(43) International Publication Date
21 June 2007 (21.06.2007)

PCT

(10) International Publication Number
WO 2007/069159 A2

- (51) International Patent Classification:
G09G 3/36 (2006.01)
- (21) International Application Number:
PCT/IB2006/054693
- (22) International Filing Date:
8 December 2006 (08.12.2006)
- (25) Filing Language: English
- (26) Publication Language: English
- (30) Priority Data:
05112275.2 16 December 2005 (16.12.2005) EP
- (71) Applicant (for all designated States except US): **NXP B.V.**
[NL/NL]; High Tech Campus 60, NL-5656 AG Eindhoven (NL).
- (72) Inventors; and
- (75) Inventors/Applicants (for US only): **OELHAFEN, Patrick** [CH/CH]; c/o NXP Semiconductors, IP Department, Cross Oak Lane, Redhill Surrey RH1 5HA (GB). **BRUNNER, Patrick** [CH/CH]; c/o NXP Semiconductors,

- IP Department, Cross Oak Lane, Redhill Surrey RH1 5HA (GB).
- (74) Agents: **WHITE, Andrew, G.** et al.; c/o NXP Semiconductors, IP Department, Cross Oak Lane, Redhill Surrey RH1 5HA (GB).
- (81) Designated States (unless otherwise indicated, for every kind of national protection available): AE, AG, AL, AM, AT, AU, AZ, BA, BB, BG, BR, BW, BY, BZ, CA, CH, CN, CO, CR, CU, CZ, DE, DK, DM, DZ, EC, EE, EG, ES, FI, GB, GD, GE, GH, GM, GT, HN, HR, HU, ID, IL, IN, IS, JP, KE, KG, KM, KN, KP, KR, KZ, LA, LC, LK, LR, LS, LT, LU, LV, LY, MA, MD, MG, MK, MN, MW, MX, MY, MZ, NA, NG, NI, NO, NZ, OM, PG, PH, PL, PT, RO, RS, RU, SC, SD, SE, SG, SK, SL, SM, SV, SY, TJ, TM, TN, TR, TT, TZ, UA, UG, US, UZ, VC, VN, ZA, ZM, ZW.
- (84) Designated States (unless otherwise indicated, for every kind of regional protection available): ARIPO (BW, GH, GM, KE, LS, MW, MZ, NA, SD, SL, SZ, TZ, UG, ZM, ZW), Eurasian (AM, AZ, BY, KG, KZ, MD, RU, TJ, TM), European (AT, BE, BG, CH, CY, CZ, DE, DK, EE, ES, FI,

[Continued on next page]

(54) Title: APPARATUS AND METHOD FOR COLOR SHIFT COMPENSATION IN DISPLAYS

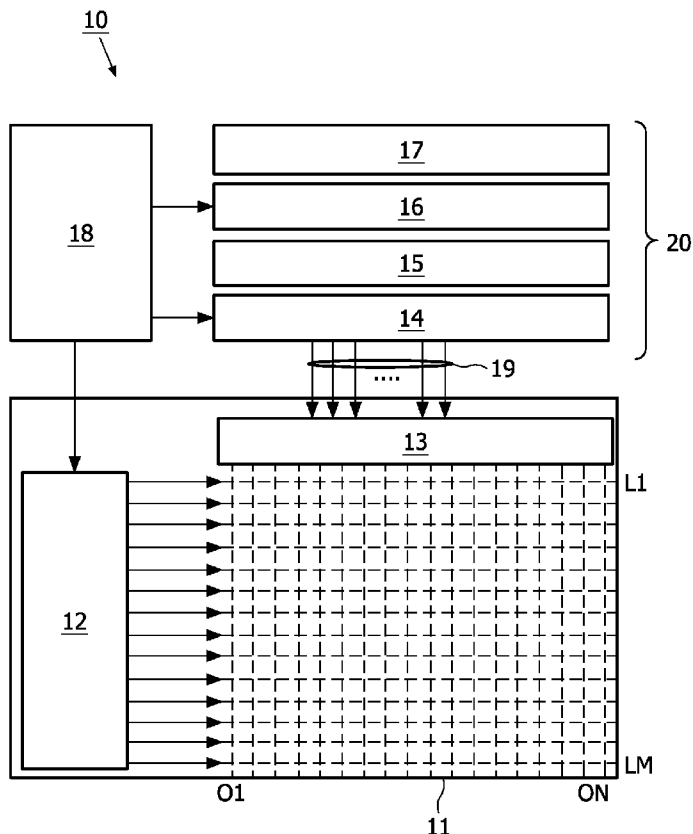

(57) Abstract: Active matrix display module (10) comprising a driving circuit with a source driver (20) and a gate driver (12). Furthermore, a display panel (11) with pixels consisting of three sub-pixels is provided. The sub-pixels are arranged in rows and columns and each sub-pixel comprises a sub-pixel selection transistor arranged at an intersection of a row and a column. The gate driver (12) is employed to select and deselect all pixels of a row of the display panel (11) and the source driver (20) is employed for providing the required voltage levels to all sub-pixels of a currently selected row, said voltage levels corresponding to the desired intensity for each color. Demultiplexer switches (21) are integrated onto the display panel (11) for demultiplexing columns of the display panel (11). The active matrix display module (10) further comprises means (18) for color shift compensation. These means (18) implement a selection order for the selection of the sub-pixels to compensate unintentional color shifts. The compensation takes place within two frames.

WO 2007/069159 A2



FR, GB, GR, HU, IE, IS, IT, LT, LU, LV, MC, NL, PL, PT,
RO, SE, SI, SK, TR), OAPI (BF, BJ, CF, CG, CI, CM, GA,
GN, GQ, GW, ML, MR, NE, SN, TD, TG).

Published:

— *without international search report and to be republished
upon receipt of that report*

Declaration under Rule 4.17:

— *as to applicant's entitlement to apply for and be granted a
patent (Rule 4.17(ii))*

*For two-letter codes and other abbreviations, refer to the "Guid-
ance Notes on Codes and Abbreviations" appearing at the begin-
ning of each regular issue of the PCT Gazette.*

DESCRIPTION

**APPARATUS AND METHOD FOR COLOR SHIFT COMPENSATION IN
DISPLAYS**

The invention concerns active matrix display modules and methods for the color shift compensation implemented in active matrix display modules.

The driving circuit for an active matrix LCD (AMLCD) can be divided in two parts: a source and a gate driver. The gate driver controls the gates of the on glass transistors to select and deselect all pixels of a specific row. Each pixel consists of three sub-pixels (red, green, blue) and each sub-pixel has its own storage capacitor. The source drivers provide the required voltage level to all sub-pixels of the currently selected row corresponding to the desired intensity for each color. The final color is obtained by the ability of the human eye to mix combinations of the three base colors (red, green, blue) into one.

When the previously selected row is deselected by the gate driver, all of this row's sub-pixels become isolated and the voltage level for each sub-pixel is maintained by a storage capacitor and a pixel capacitance. The period, in which every display row is selected exactly once, is typically referred to as a 'frame'.

In Fig. 1 an example of an active matrix LTPS (low temperature polysilicon) display module 10 is schematically depicted. In this LTPS display module 10, the gate driver circuit 12 is integrated directly into the display glass 11. This is possible since the gate driver 12 typically only comprises circuits that can easily be implemented on the display glass 11. Note that in theory, the gate driver could reside in a separate chip as well. The source drivers can either be integrated on-glass or in a separate chip. In Fig. 1 an embodiment is shown where the demultiplexers 13 are integrated on the display glass 11. The multiplexers 14, source output drivers 15, latches 16, buffer 17 and control circuit 18 are realized in a separate source driver chip 20. The display panel has in the present example N columns and M rows. If a multiplexing rate of 1:3 is employed, only N/3 source driver lines 19 are required to connect the source driver chip 20 with the display panel 11. The LTPS technology allows the integration of demultiplexers on the display glass which dramatically reduces the amount of required source driver lines 19. LTPS is an example only. The invention which will be addressed later is not LTPS specific.

In cases where the source driver circuit is integrated on-chip, too, the on-glass demultiplexing method reduces the amount of source output pads needed to drive a specific display size. Or, in other words, it increases the possible display size that can be driven by a single chip. In case of multiplexing, the source lines are grouped, e.g. 3 sub-pixels per
 5 multiplexing group for a mux rate of 1:3 or 6 sub-pixels per multiplexing group for a mux rate of 1:6. When a row is selected, the sub-pixels therein are not charged all at the same time but the source lines of one group are charged sequentially. For instance in a multiplexing 1:3 case, first all red sub-pixels are selected, then all green sub-pixels, and finally all blue sub-pixels. After that, the row is deselected, and the next row becomes selected, followed again
 10 by charging the red sub-pixels, and so on. This case is schematically illustrated in Fig. 2. In this Figure two rows R_{N+1} and R_N and three columns $n-1$, n , $n+1$ are illustrated. Each pixel has, as mentioned above, three sub-pixels. In Fig. 2 the sub-pixels of column $n-1$ are denoted as (red) R_{n-1} , (green) G_{n-1} , and (blue) B_{n-1} . The source driver lines 19 are denoted as S_{n-1} , S_n , and S_{n+1} . The switches of the demultiplexer 13 carry the reference number 21 and the
 15 demultiplexer selection lines carry the reference number 22. C_p are the parasitic capacitances between two adjacent source lines and C_{pix} are the pixel capacitances. Furthermore, each sub-pixel comprises a sub-pixel selection transistor arranged at an intersection of a row and a column. One such sub-pixel selection transistor carries the reference number 23.

The drawback of the demultiplexing method is the so-called color shift. When
 20 a row is selected, all the on-glass sub-pixel selection transistors 23 for this row are conducting. As shown in Fig. 3, charging a sub-pixel influences the neighboring pixels (which were charged before) through the parasitic capacitances C_p between two lines (mainly the adjacent lines). The demultiplexer selection signals are shown on the left hand side right next to the demultiplexer selection lines 22. In Fig 3 the color shift is denoted by ϵB & ϵG .
 25 Therefore, only the sub-pixels which were charged as the last ones in a row, carry the correct voltage level when the row becomes deselected (the blue sub-pixel in case of Fig. 3).

The state of the art technique to compensate the color shift effect is to rotate the pixel order selection from frame to frame. In this way, the last charged pixels (those with the correct color) of a specific row are in each frame different. The color of the last selected
 30 sub-pixel is then correct and the error on each sub-pixel partially averages out over 3 frames for a mux-rate of 1:3 (or 6 frames for mux-rate 1:6, respectively). Depending on the frame frequency and on the multiplexing factor the amount of required frames to average out the errors might become too long and will be perceived as flicker on the display. Especially for high multiplexing rates, a high frame frequency must be applied to avoid flickering.

The drawback of this method is, that the color shift is only slowly compensated (over several frames) and a certain deviance will always remain.

5 It is an object of the present invention to provide a better and faster color compensation scheme.

This and other objects are accomplished by an apparatus according to claim 1 and the methods according to claims 8 and 10. Further advantageous implementations are given in the dependent claims.

10 According to the present invention, the color shift is compensated using a smart selection order for the sub-pixels. According to the present invention the compensation takes place within two frames. During the first frame the color shift is partially compensated and during the second frame, the color shift is completely compensated.

According to the present invention an active matrix display module is
15 provided that comprises a driving circuit with a source driver and a gate driver. Furthermore, a display panel with pixels consisting of three sub-pixels is provided. The sub-pixels are arranged in rows and columns and each sub-pixel comprises a sub-pixel selection transistor arranged at an intersection of a row and a column. The gate driver is employed to select and
20 deselect all pixels of a row of the display panel and the source driver is employed for providing the required voltage levels to all sub-pixels of a currently selected row, said voltage levels corresponding to the desired intensity for each color. Demultiplexer switches are integrated onto the display panel for demultiplexing rows of the display panel. The active matrix display module further comprises means for color shift compensation. These means
25 implement a selection order for the selection of the sub-pixels to compensate unintentional color shifts. The compensation takes place within two frames.

Further advantageous embodiments are addressed in connection with the detailed description.

30 For a more complete description of the present invention and for further objects and advantages thereof, reference is made to the following description, taken in conjunction with the accompanying drawings, in which:

Fig. 1 is a schematic representation of a typical active matrix display module;

Fig. 2 is a schematic representation showing part of a conventional active matrix display module;

Fig. 3 is a schematic representation showing part of a conventional active matrix display module and a prior art selection scheme;

5 Figs. 4A-4C are a schematic representation showing part of an active matrix display module and details of the inventive selection scheme and the steps carried out during a first frame;

10 Figs. 5A-5C are a schematic representation showing part of an active matrix display module and details of the inventive selection scheme and the steps carried out during a second frame;

Figs. 6A-6C are a schematic representation showing part of an active matrix display module and details of the inventive selection scheme and the steps carried out during a third frame;

15 Figs. 7A-7C are a schematic representation showing part of an active matrix display module and details of the inventive selection scheme and the steps carried out during a fourth frame;

Figs. 8A-8F are a schematic representation showing part of an active matrix display module and details of the inventive selection scheme and the steps carried out during a first frame;

20 Figs. 9A-9F are a schematic representation showing part of an active matrix display module and details of the inventive selection scheme and the steps carried out during a second frame.

25 According to the present invention, the color shift is compensated by a smart selection order employed when selecting the sub-pixels. This is done within two frames.

In the first frame, the color shift is partially compensated, and in the second frame completely. In this way, flicker (which might be present in the prior art solution) is avoided.

30 The inventive selection order proposed herein is also chosen to minimize power consumption.

The basic idea is based on the following physical properties:

1. Assuming a row is selected and the sub-pixel n of this row has been charged: If the adjacent sub-pixel $n+1$ and the adjacent sub-pixel $n-1$ of this row are charged with

opposite voltage polarities (one with a positive voltage and the other with a negative voltage), then the color shift on the pixel n is attenuated (partially compensated).

2. Assuming a row is selected and two adjacent sub-pixels of this row are selected at the same time: In this case, the voltage level charged on either sub-pixel does not have an impact on the voltage level charged on the other one.

3. The sub-pixel selection order can be chosen in such a way that in one frame the same absolute value of color shift as in the next frame is obtained but with opposite polarity. In this way the color shift is averaged out over two frames.

4. Assuming a row is selected and a sub-pixel n from this row has already been charged. If now the next sub-pixel (e.g., sub-pixel $n-2$, $n-3$, ... or sub-pixel $n+2$, $n+3$, ...), which is not adjacent to sub-pixel n , is being charged, then the color shift on sub-pixel n is considered to be very small.

Two different embodiments of this smart color shift compensation are now addressed in connection with the corresponding drawings.

Before addressing the two exemplary embodiments, some basic aspects of the schematic drawings are explained.

In the Figures, part of a display panel 11 is shown. The display panel 11 comprises pixels consisting of three sub-pixels (R_n , G_n , B_n). The sub-pixels are arranged in rows where the row line (horizontal) is called gate line. Each sub-pixel comprises a sub-pixel selection transistor 23 arranged at an intersection of a row and a column. The sub-pixel selection transistors 23 in a row are all connected to individual, i.e. different, data lines (vertical/column lines). A gate driver 12 is employed to select and deselect all pixels of a row of the display panel 11. A source driver 20 provides the required voltage levels to all sub-pixels of a currently selected row of said display panel 11, said voltage levels corresponding to the desired intensity for each color.

If a multiplexed display implementation is used, the corresponding demultiplexer switches may be integrated onto the display panel 11 for demultiplexing the data lines of the display panel 11. In Fig. 4A one demultiplexer switch is denoted as 21.1.

The control circuit 18 may comprise a demultiplexer logic or a sequencer to control the demultiplexer switches 21 in accordance with the present invention. That is, the control circuit 18 provides the right signals in order to switch the demultiplexer switches 21 so that the above-identified properties are satisfied.

A first embodiment of the invention is designed for a multiplexing rate (mux rate) of 1:3. In this particular embodiment the above-mentioned properties 1, 2, and 3 are

being used. It is to be noted that according to the invention other selection orders than described here are possible too.

In the following one possible solution is explained, where the charging of the pixels is divided into the following steps:

5 Frame 1 (see Figures 4A through 4C):

1. The row R_N is selected by the gate driver 12.

2. All sub-pixels (G_{n-1} , G_n , and G_{n+1}) in the middle of a multiplexing group of the row R_N are charged (cf. Fig 4A). This is done by applying a respective signal pulse muxsel <1> on the corresponding demultiplexer selection line 22.1 so that the demultiplexer
10 selection line 22.1 becomes a logic one for a short period of time. Note that the sub-pixel G_{n-1} is charged with a positive, the sub-pixel G_n with a negative, and the sub-pixel G_{n+1} with a positive voltage, as indicated right next to the source driver lines 19.

3. One of the neighboring sub-pixels (sub-pixel B_{n-1} in the present example) is charged with one voltage polarity (assuming positive), since the respective signal pulse
15 muxsel <2> on the corresponding demultiplexer selection line 22.2 is a logic one for a short period of time. In order to take advantage of property 2, the adjacent sub-pixel (sub-pixel R_n in the present example) of the adjacent multiplexing group is selected at the same time (in this way these two sub-pixels (B_{n-1} and R_n) are not influencing each other) (cf. Fig 4B, V_R is not influenced by V_B).

20 4. Then, the other neighbor (sub-pixel R_{n-1} in the present example) of the middle sub-pixel (sub-pixel G_{n-1} in the present example) is charged with the opposite voltage polarity (assuming negative), since the respective signal pulse muxsel <0> on the corresponding demultiplexer selection line 22.0 is a logic one for a short period of time. This takes advantage of property 1 (in this way the influence on the sub-pixel in the middle (sub-pixel
25 G_{n-1} in the present example) is partially attenuated). Like in step 2 above, the two adjacent sub-pixels (B_n and R_{n+1}) of the two adjacent multiplexing groups are selected simultaneously. In this way, these two sub-pixels (B_n and R_{n+1}) are not influenced by each other. Finally, all pixels of the row R_N have been charged and the only sub-pixel suffering slightly from color shift is the sub-pixel in the middle (cf. Fig 4C).

30 5. The previous steps are repeated for every row until the whole display has been addressed.

In this way the frame 1 has been completed.

Frame 2 (see Figures 5A through 5C):

6. To compensate the color shift, in this 2nd frame the polarity of the two adjacent sub-pixels (R_n and B_n) of the middle one (G_n) has to be inverted. The middle one (sub-pixel G_n) is charged with the same polarity as in frame 1. The selection order of the neighbor pixel is different with respect to the previous frame to save current consumption, that is the sub-pixel B_n is selected before the sub-pixel R_n is selected. The source lines 19 do not have to be charged to the opposite voltage polarity (cf. Figures 5A – 5C).

Figures 4C and 5C show that the color shifts ϵB and ϵR are compensated by averaging over frame 1 and frame 2 (see the above-mentioned property 3).

7. The step 6 is repeated for every row until the whole display has been addressed.

In this way the frame 2 has been completed and the color shift is compensated.

Frames 3 and 4 (see Figures 6A through 6C and Figures 7A through 7C):

8. To avoid the deterioration of the liquid crystal of the display panel 11 the DC value on each sub-pixel should be averaged out to 0V. To eliminate the DC level on each sub-pixel the two frames 1 and 2 have to be repeated but with inverted polarity (see Figures 6A through 6C and Figures 7A through 7C).

It is to be noted that the step 8 (carried out during the 3rd and 4th frame) is optional.

A second embodiment of the invention is designed for a multiplexing rate (mux rate) of 1:6. In this particular embodiment the above-mentioned properties 1, 3, and 4 are being used. It is to be noted that according to the invention other selection orders than described here are possible too.

In the following one possible solution is explained, where the charging of the pixels is divided into the following steps:

Frame 1 (see Figures 8A through 8F):

1. The row R_N is selected by the gate driver 12.

2. Then three sub-pixels of every demultiplexer group are selected sequentially (respectively in the order: sub-pixels 5, 3, 1, for instance). In Fig. 8A sub-pixel 5 is selected.

In Fig. 8B the sub-pixel 3 is selected and in Fig. 8C the sub-pixel 1 is selected. The selection order is such that every second sub-pixel (cf. Fig. 8A to Fig. 8C) will be selected and the others later (cf. step 3 below). In this way the property 4 is used. Like for multiplexer rate 1:3, two demultiplexer groups have always opposite pixel polarities.

3. Then the sub-pixels 4, 2, 6 will be charged sequentially, but in a way that each sub-pixels 5, 3, 1 has on the left and right hand side sub-pixels with inverse polarity (use of property 1) (cf. Fig. 8D to Fig. 8F).

4. The previous steps 1 – 3 are repeated for every row until the whole display has
5 been addressed.

The 1st frame is then completed. Through the parasitic capacitor (C_p) between source tracks a color shift (respectively ε_1 to ε_5) will appear on some sub-pixels, as shown in Figures 8D through 8F.

Frame 2 (see Figures 9A through 9F):

10 5. In the next frame the sub-pixels 5, 3, 1 are charged identically to the first frame (Fig. 9A to Fig. 9C).

6. Then the remaining sub-pixels will be charged with the inverse polarity with respect to the previous frame (use of property 3). In order to minimize the current consumption the selection order is respectively: subpixels 2, 6, 4 (Fig. 9D to Fig. 9F). This
15 minimizes the amount of polarity inversions during the charging sequence. Through the parasitic capacitor (C_p) between source tracks the color shifts ε_6 to ε_9 will appear on some sub-pixels. However, these shifts will be eliminated before the end of the pixel charging sequence and will not influence the displayed image. The remaining color shifts on some pixels (ε_1 to ε_5) are eliminated by averaging with frame 1 (compare Fig. 8F and Fig. 9F).

20 7. The above steps 5 and 6 are repeated for every row until the whole display has been addressed.

In this way the frame 2 has been completed and the color shift is compensated.

Frame 3

8. In the frame 3 the DC value of frame 1 is averaged to 0V on each sub-pixel.

25 This is realized by repeating the same frame as frame 1 but with each sub-pixel charged with inverted polarity with respect to frame 1.

Frame 4

9. In the frame 4 the DC value of frame 2 is averaged to 0V on each sub-pixel.

This is realized by repeating the same frame as frame 2 but with each sub-pixel charged with
30 inverted polarity with respect to frame 2.

To avoid the deterioration of the liquid crystal the DC value on each sub-pixel may be averaged out to 0V. This is realized in four frames. However, the color shift is partially compensated in each frame and completely over two frames, i.e. over frame 1 to frame 2 and over frame 3 to frame 4, respectively.

For the purposes of color shift compensation thus two frames are sufficient. A scheme involving 4 frames is only necessary if one also wants avoid the deterioration of the liquid crystal.

5 The selection order for the selection of the sub-pixels is typically implemented inside the control circuit 18. This control circuit 18 provides the appropriate selection signals taking into account two or more of the properties 1 through 4 identified above.

As mentioned above, the present invention is intended to be used in LCD drivers where the source lines are multiplexed. Very well suited is the present invention for small displays, such as the ones used in mobile phones, PDAs, and the like.

10 In the drawings and specification there have been set forth preferred embodiments of the invention and, although specific terms are used, the description thus given uses terminology in a generic and descriptive sense only and not for purposes of limitation. In this context it is to be mentioned that the invention was made during the development for an LTPS driver. The invention, as described and claimed herein, however,
15 also applies to other active matrix technologies (such as high temperature polysilicon) too.

CLAIMS:

1. Active matrix display module (10) comprising:
 - a driving circuit with a source driver (20) and a gate driver (12),
 - a display panel (11) with pixels consisting of three sub-pixels (R_n, G_n, B_n) being arranged in rows (R_N) and columns, each sub-pixel (R_n, G_n, B_n) comprising a sub-pixel selection transistor (23) arranged at an intersection of a row and a column,
5
 - said gate driver (12) being employed to select and deselect all pixels of a row (R_N) of said display panel (11),
 - said source driver (20) being employed for providing required voltage levels to all sub-pixels (R_n, G_n, B_n) of a currently selected row (R_N) of said display panel (11), said
10 voltage levels corresponding to the desired intensity for each color,
 - demultiplexer switches (21) being integrated onto the display panel (11) for demultiplexing columns (R_N) of said display panel (11), and
 - means (18) for color shift compensation implementing a selection order for the selection of the sub-pixels (R_n, G_n, B_n) in order to compensate unintentional color shifts, said
15 compensation taking place within two frames.
2. The display module (10) of claim 1, wherein the during the color shift compensation in a first frame the color shift is partially compensated and in a second frame the color shift is completely compensated.
20
3. The display module (10) of claim 2, wherein during a third frame the DC value of the first frame is averaged to 0V on each sub-pixel and during a fourth frame the DC value of the second frame is averaged to 0V on each sub-pixel in order to avoid the deterioration of the display panel (11).
25
4. The display module (10) of claim 1 or 2, wherein said source driver (20) and/or said gate driver (12) is integrated into a display glass forming the display panel (11).

5. The display module (10) of claim 1 or 2, wherein each pixel has a storage capacitor and a pixel capacitance (C_{pix}).

6. The display module (10) of claim 4, wherein all sub-pixels of a row become isolated if this row is deselected by said gate driver (12) and wherein the voltage level for each sub-pixel is maintained by the storage capacitor and the pixel capacitance (C_{pix}).

7. The display module (10) of one of the preceding claims, wherein said display module (10) is a low temperature polysilicon display module or a high temperature polysilicon display module.

8. Method for the color shift compensation implemented in an active matrix display module (10) comprising a driving circuit with a source driver (20) and a gate driver (12), and a display panel (11) with pixels consisting of three sub-pixels (R_n , G_n , B_n) being arranged in demultiplexing columns (C_N), each sub-pixel (R_n , G_n , B_n) comprising a sub-pixel selection transistor (23) arranged at an intersection of a row and a column and corresponding demultiplexer selection lines (22.0 – 22.5) implementing a 1:3 multiplexing scheme where each pixel belongs to a different multiplexing group, the method comprising the following steps:

during a first frame:

(1) selecting a row (R_N) by the gate driver (12),

(2) charging all sub-pixels (G_{n-1} , G_n , and G_{n+1}) in the middle of a multiplexing group of said row (R_N) by applying a respective signal pulse on a corresponding demultiplexer selection line (22.1),

(3) charging one of the two neighboring sub-pixels (B_{n-1}) of each multiplexing group of said row (R_N) with a first voltage polarity, and selecting an adjacent sub-pixel (R_n) of an adjacent multiplexing group at the same time,

(4) charging the other neighbor sub-pixel (R_{n-1}) of the middle sub-pixel of each multiplexing group of said row (R_N) with a voltage polarity opposite to the first voltage polarity, whereby two adjacent sub-pixels (B_n and R_{n+1}) of the two adjacent multiplexing groups are selected simultaneously,

(5) repeating the steps (1) – (4) for every row until the whole display panel (11) is addressed,

during a second, subsequent frame:

(6) inverting the polarity of the two adjacent sub-pixels (R_n and B_n) of the middle sub-pixel (G_n) of each multiplexing group of a row (R_N) and charging the respective middle sub-pixels (G_n) with the same polarity as in step (2),

(7) repeating the step (6) for every row until the whole display has been

5 addressed.

9. The method of claim 8 whereby said first and second frames are repeated with inverted polarity in order to average out the DC value on each sub-pixel to 0V.

10 10. Method for the color shift compensation implemented in an active matrix display module (10) comprising a driving circuit with a source driver (20) and a gate driver (12), and a display panel (11) with pixels consisting of three sub-pixels (R_n , G_n , B_n) being arranged in rows (R_N) and columns, each sub-pixel (R_n , G_n , B_n) comprising a sub-pixel selection transistor (23) arranged at an intersection of a row and a column and corresponding demultiplexer selection lines (22.0 – 22.5) implementing a 1:6 multiplexing scheme
15 subdividing said display panel (11) into different multiplexing group where each multiplexing group comprises two adjacent pixels, the method comprising the following steps:

during a first frame:

20 (1) selecting a row (R_N) by the gate driver (12),

(2) sequentially charging three sub-pixels of every multiplexing group such that every second sub-pixel gets selected,

(3) sequentially charging three so far un-selected sub-pixels such that each sub-pixel that was charged during the step (2) now has on the left and right hand side sub-pixels with inverse polarity,
25

(4) repeating the previous steps (1) – (3) for every row until the whole display panel (11) is addressed,

during a second, subsequent frame:

(5) identically charging in said second frame the same three sub-pixels of every multiplexing group as in step (2),
30

(6) charging the remaining sub-pixels with the inverse polarity with respect to the steps (1) – (3),

(7) repeating the previous steps (5) and (6) for every row until the whole display panel (11) is addressed.

11. The method of claim 10 whereby in a third frame the DC value of the first frame is averaged out to 0V on each sub-pixel.

5 12. The method of claim 11 whereby in a fourth frame the DC value of the second frame is averaged out to 0V on each sub-pixel.

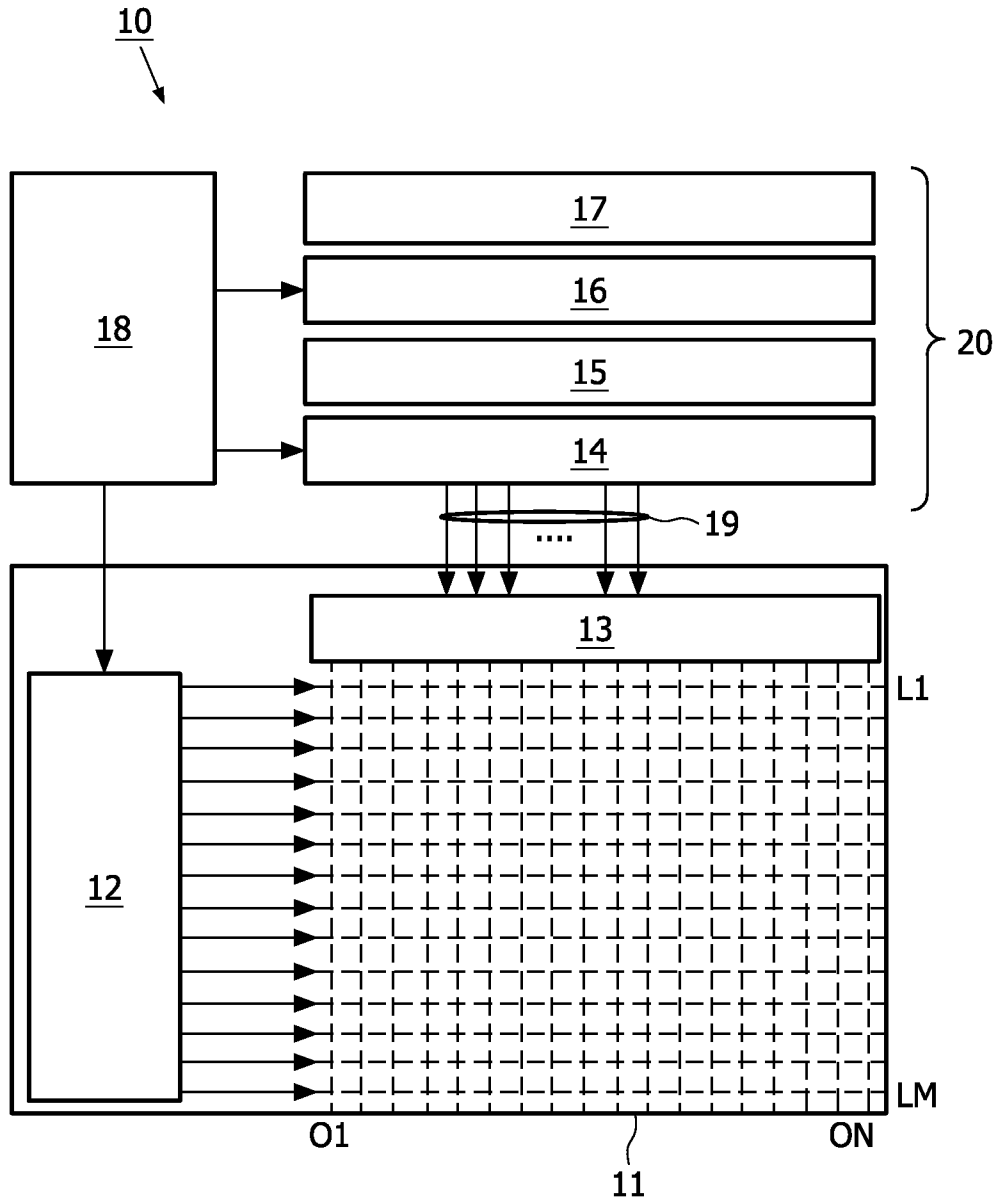

FIG. 1

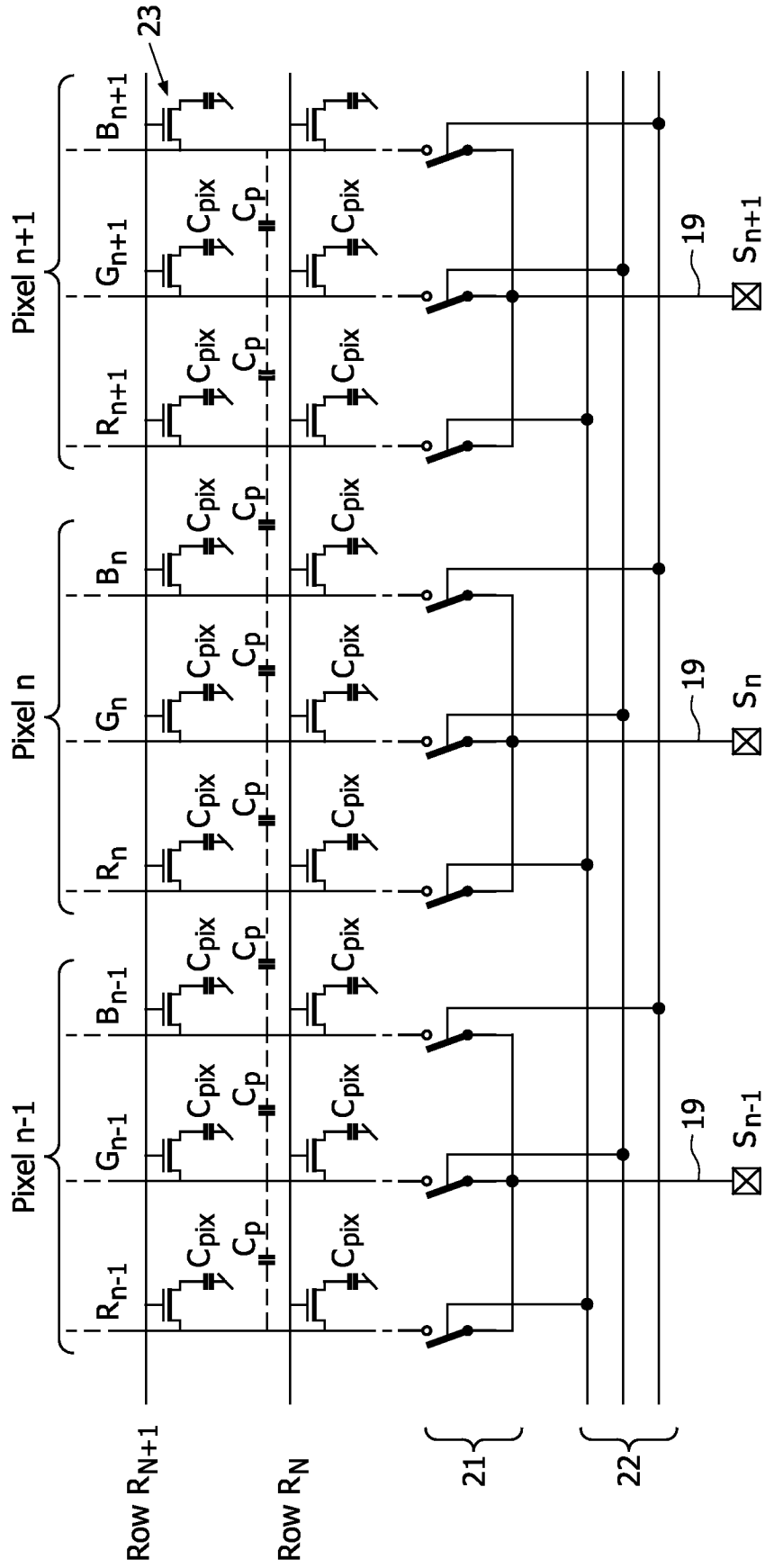

FIG. 2

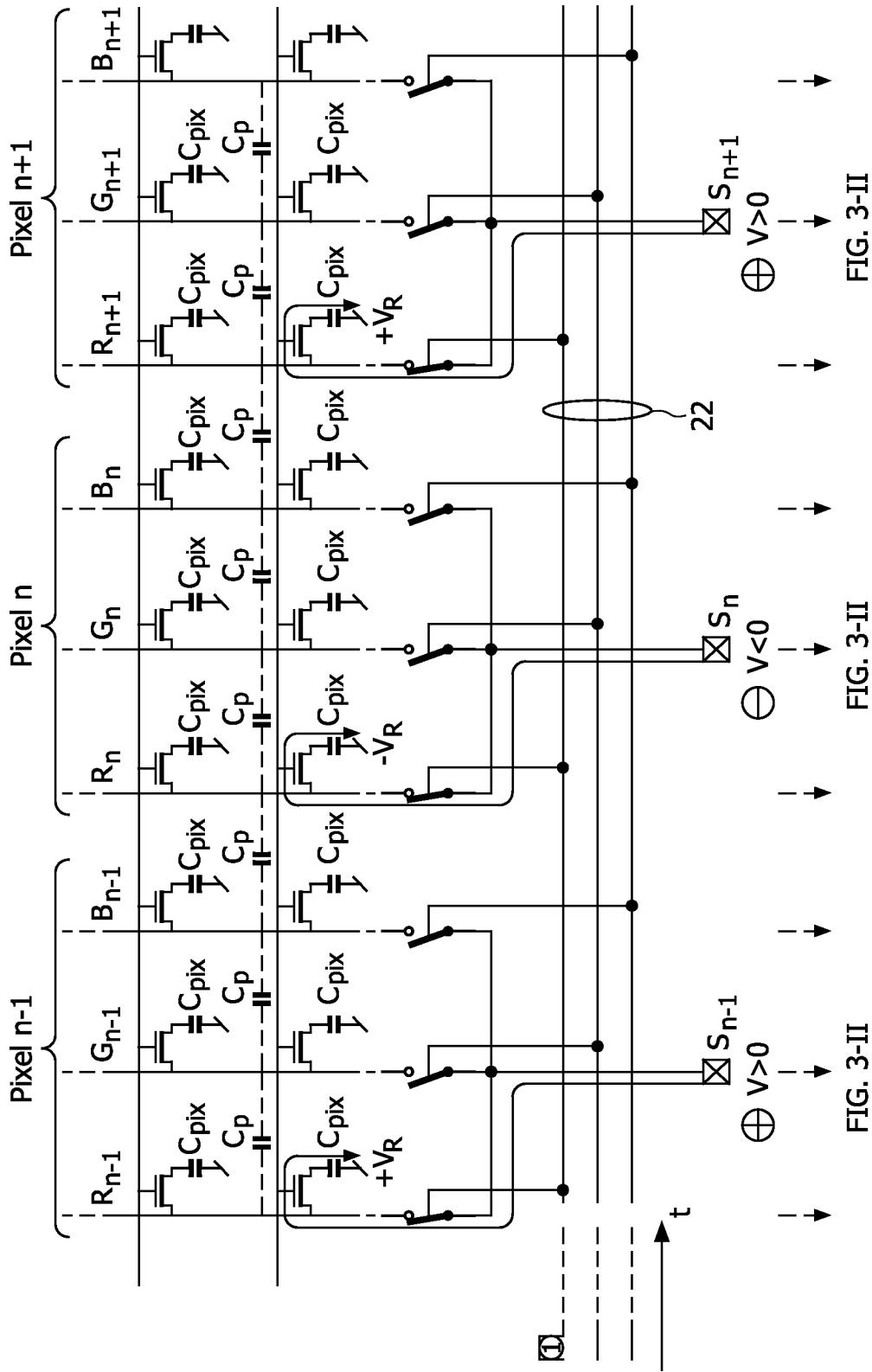

FIG. 3-II

FIG. 3-II

FIG. 3-II

FIG. 3-I

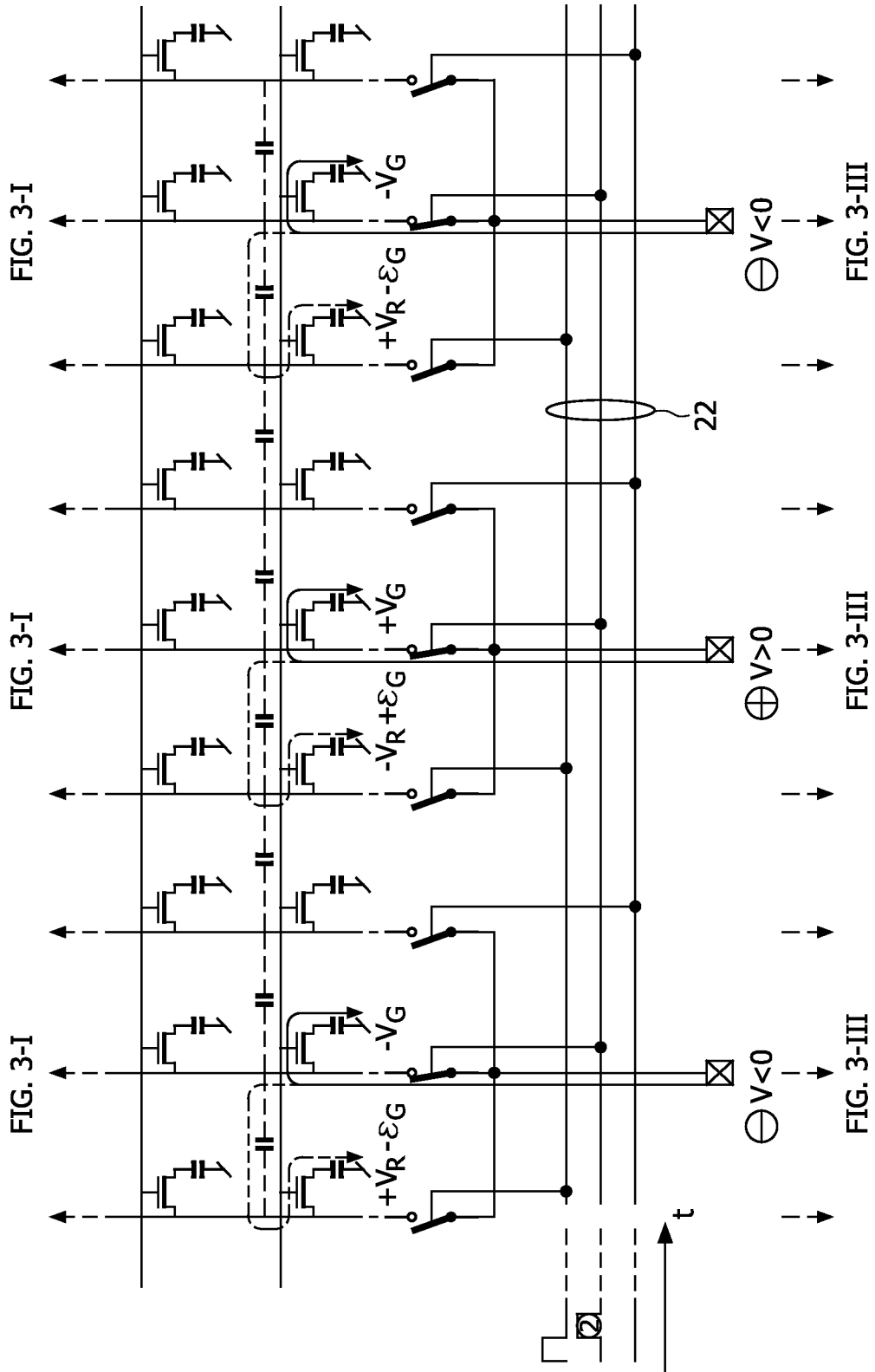

FIG. 3-II

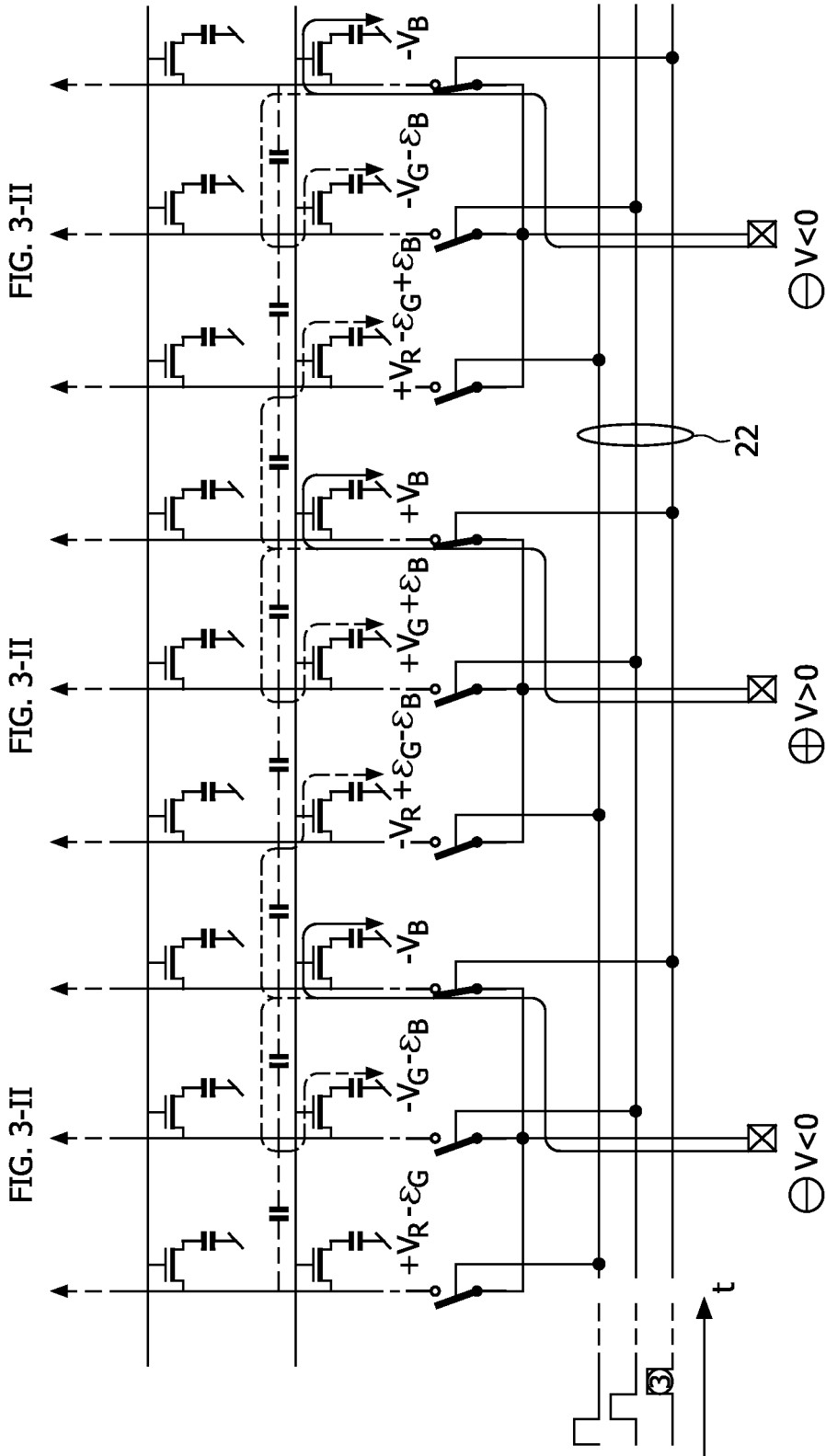

FIG. 3-III

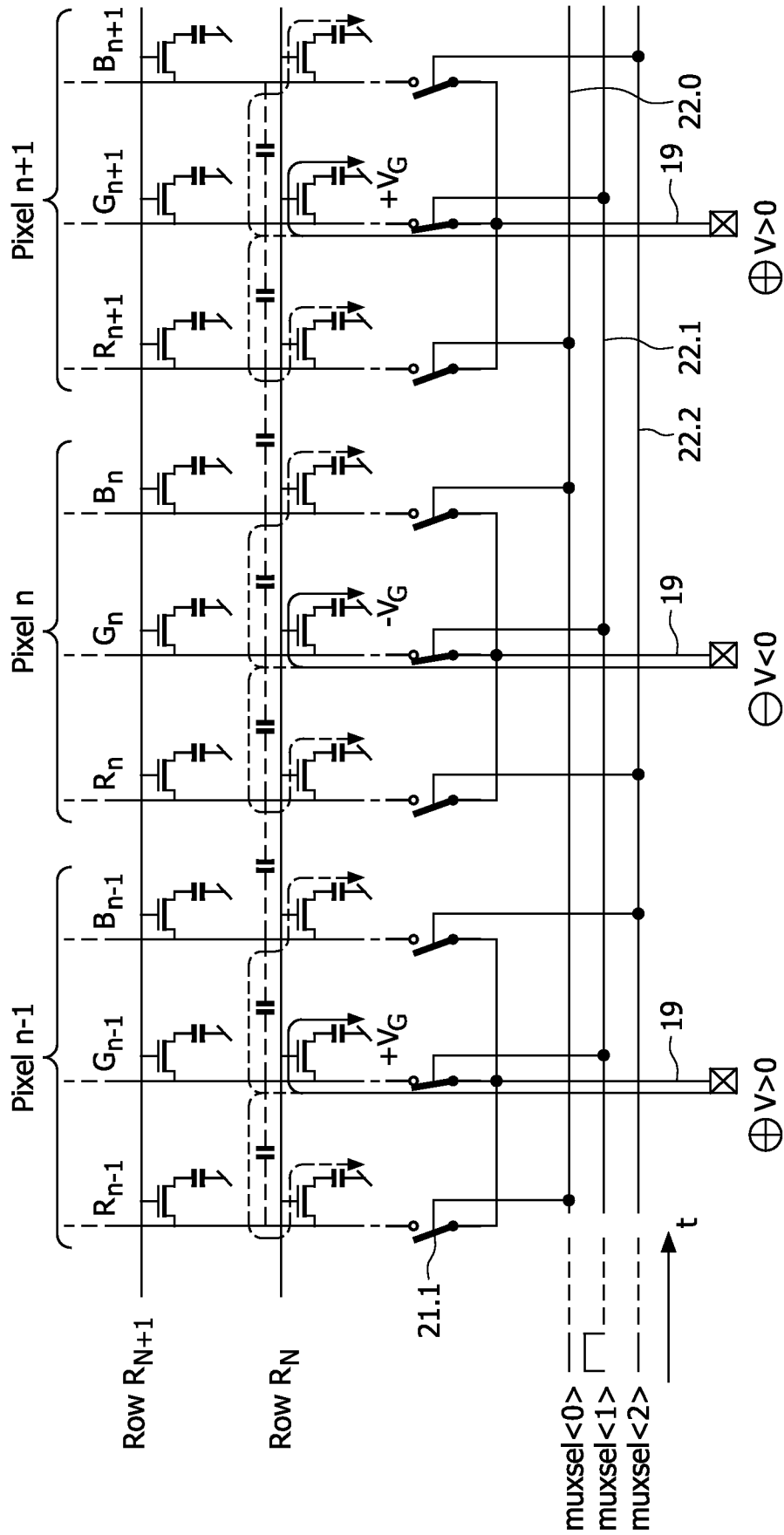

FIG. 4A

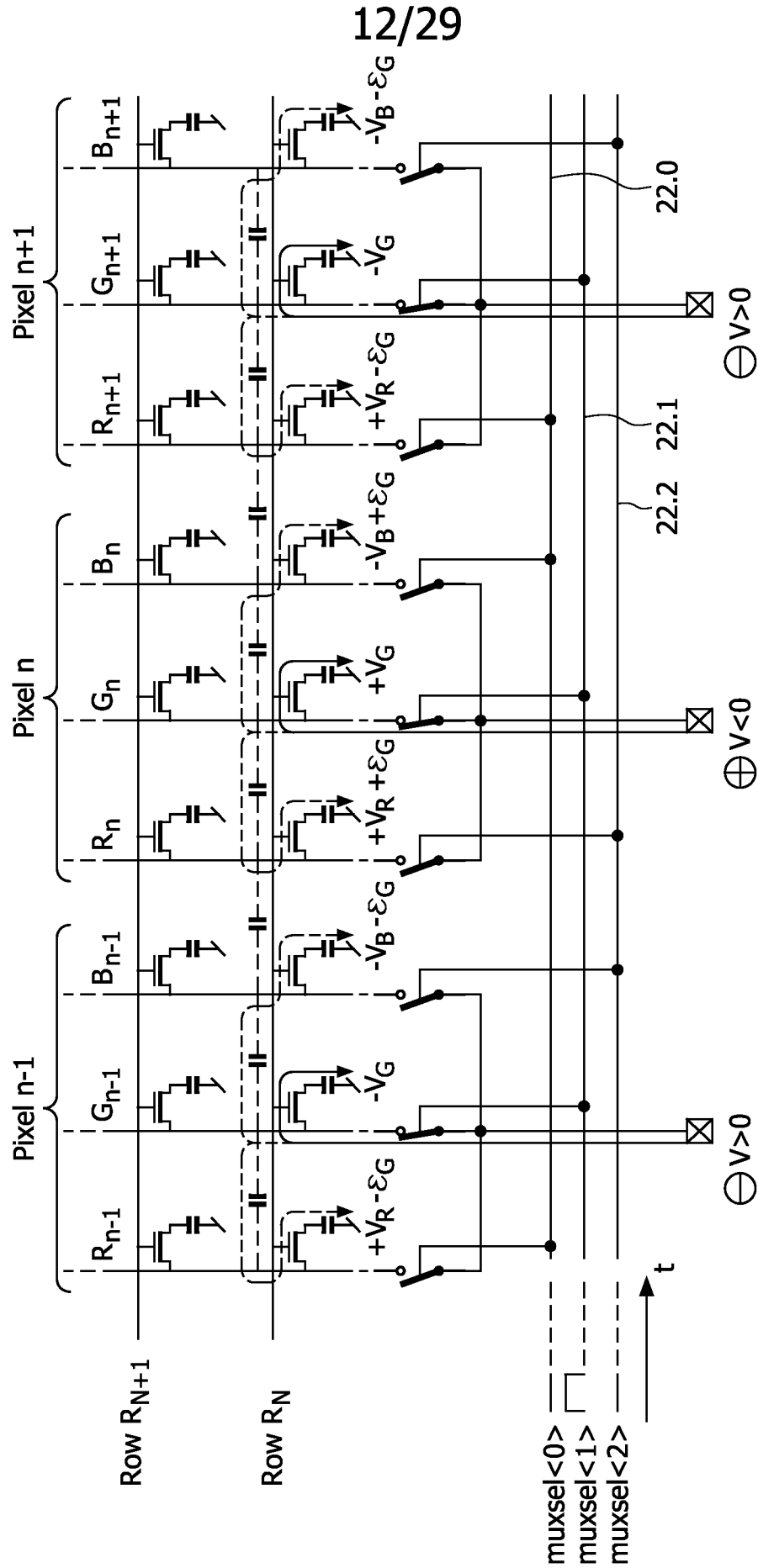

FIG. 6A

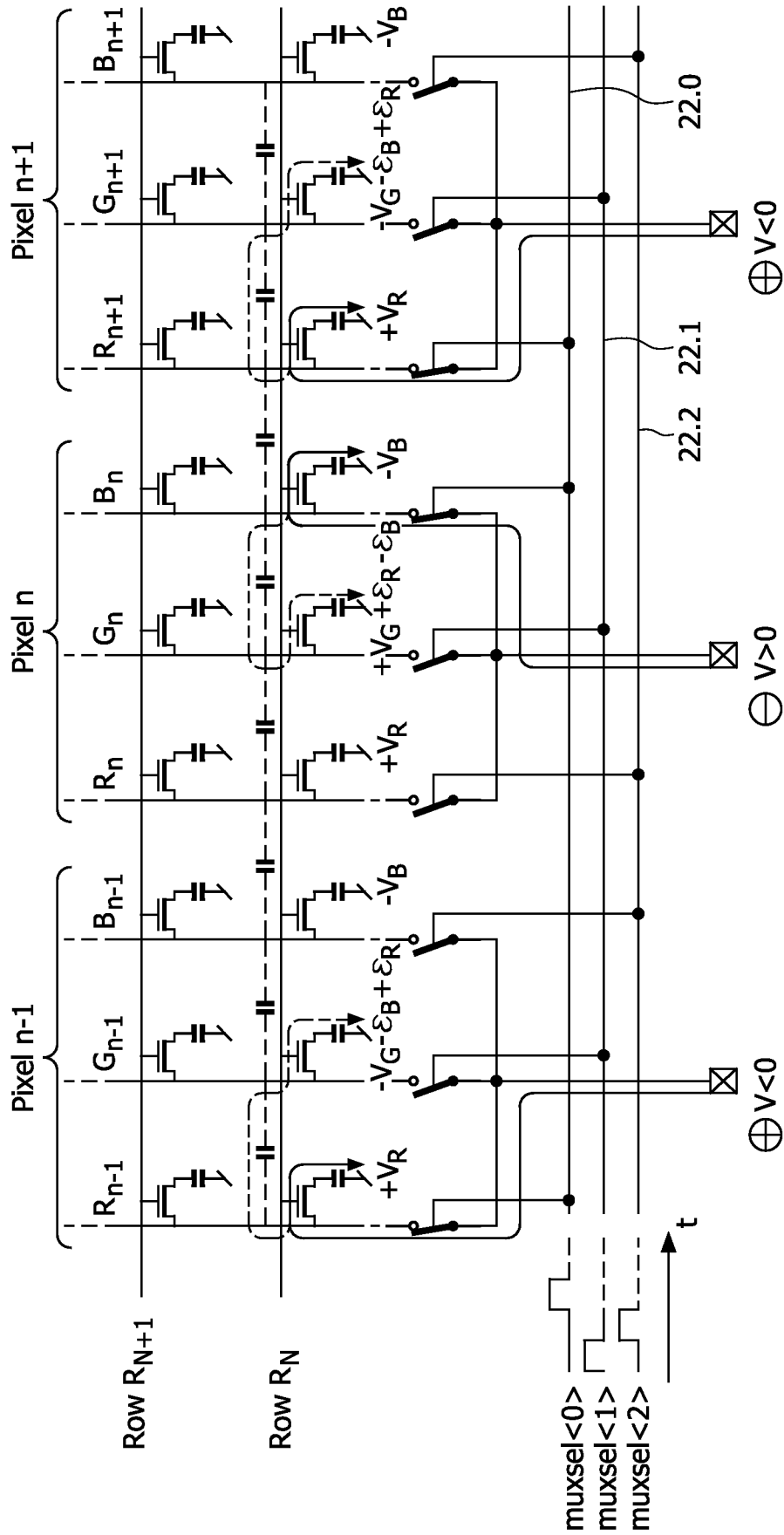

FIG. 6C

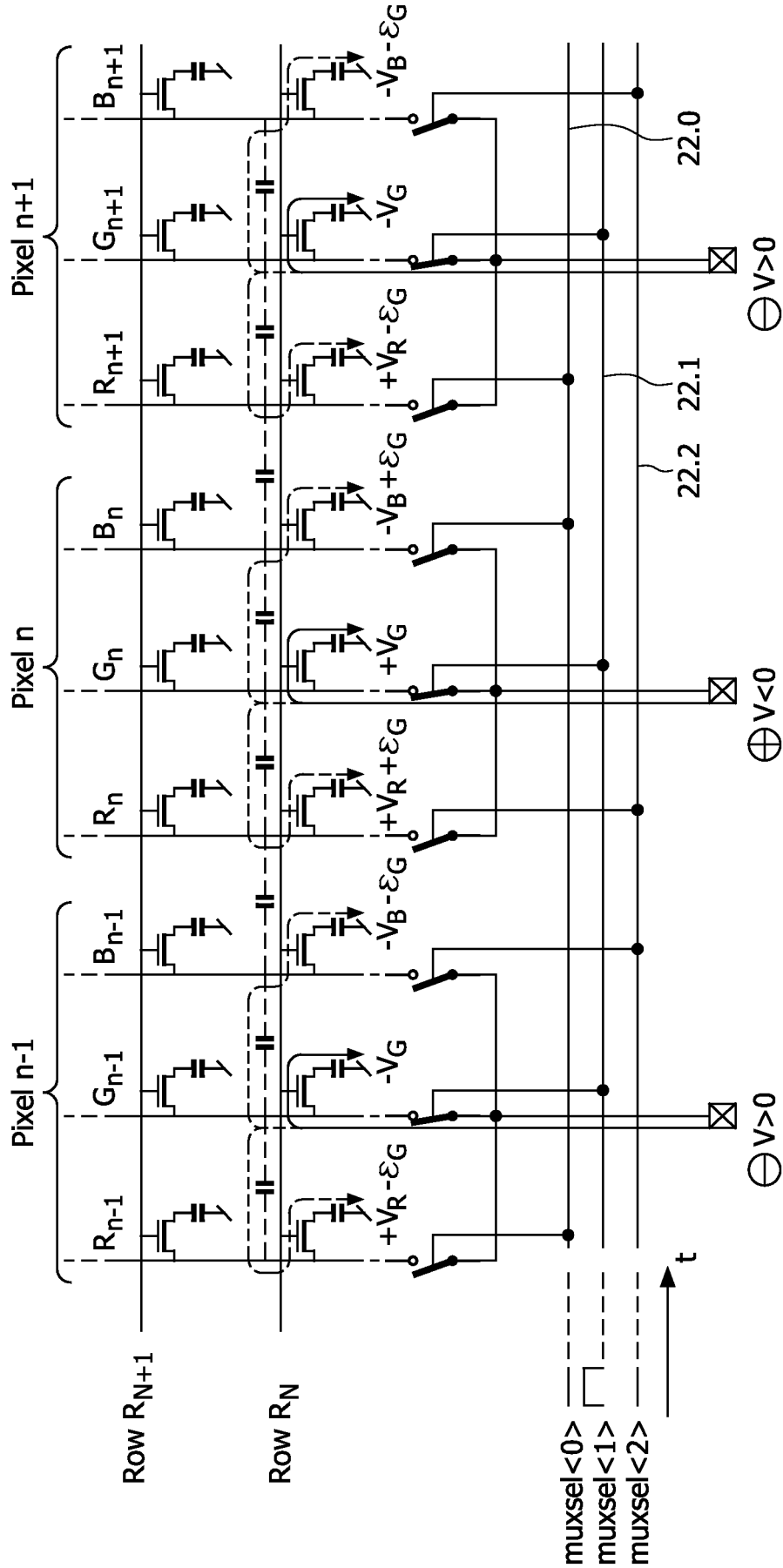

FIG. 7A

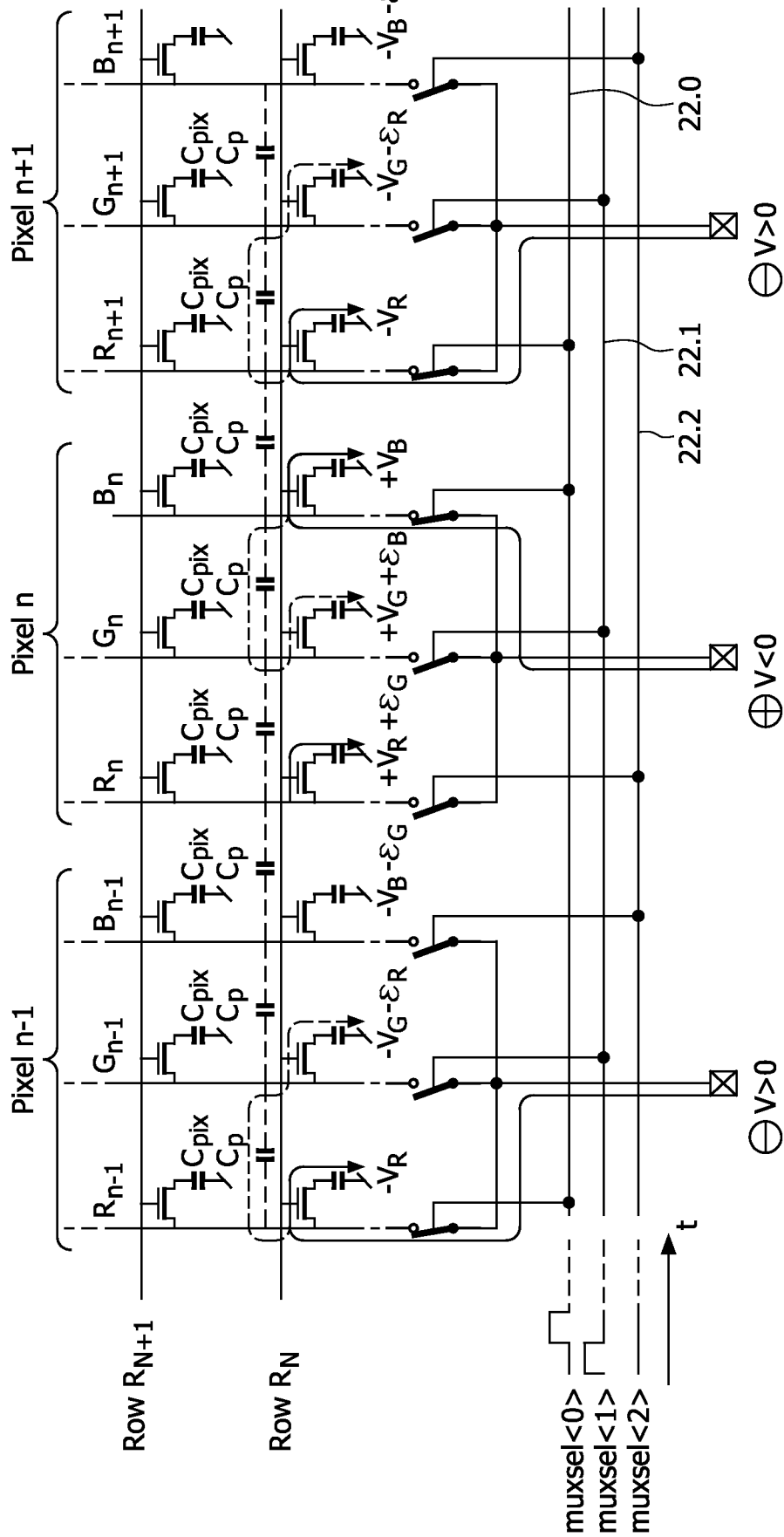

FIG. 7B

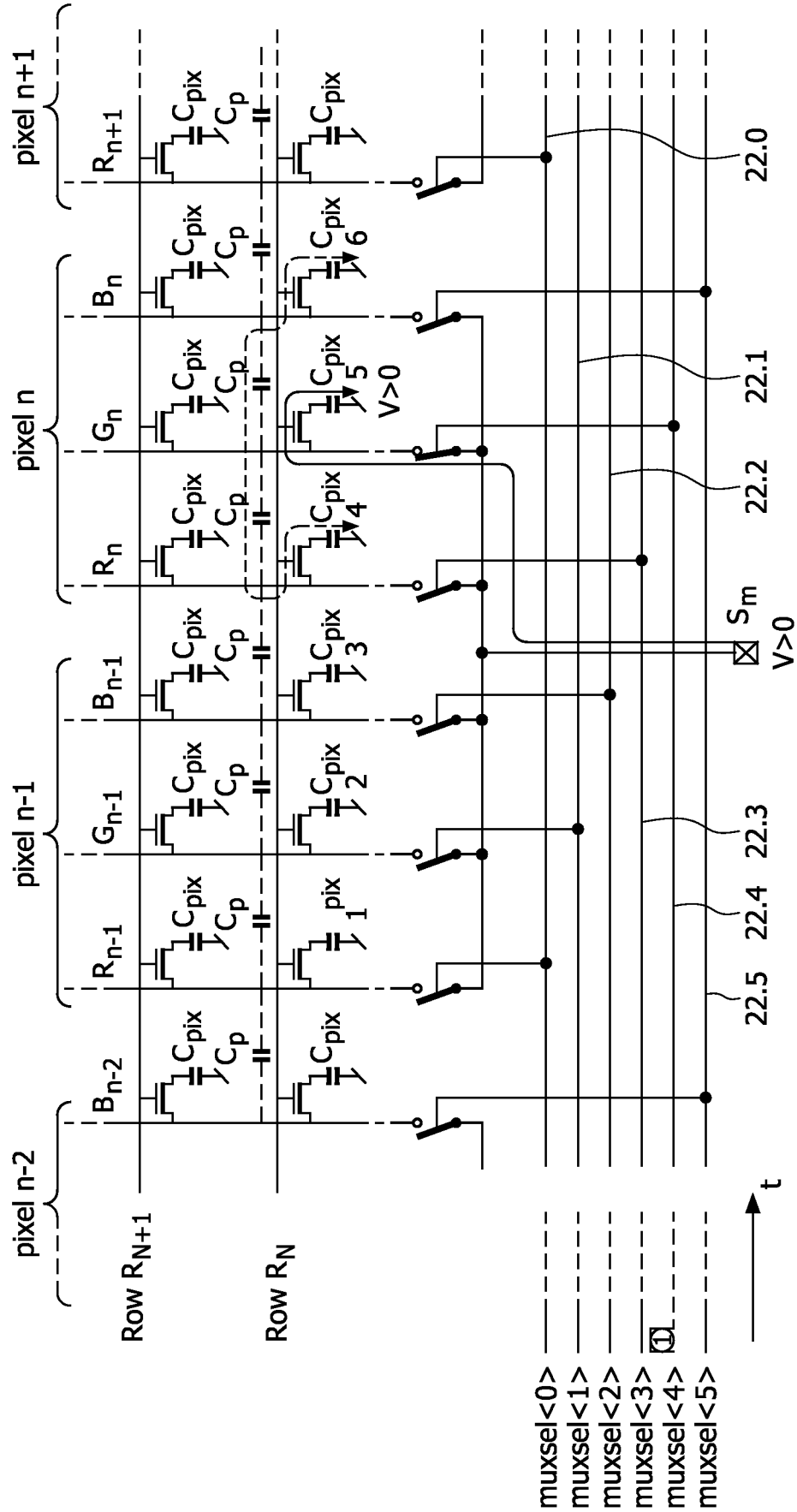

FIG. 8A

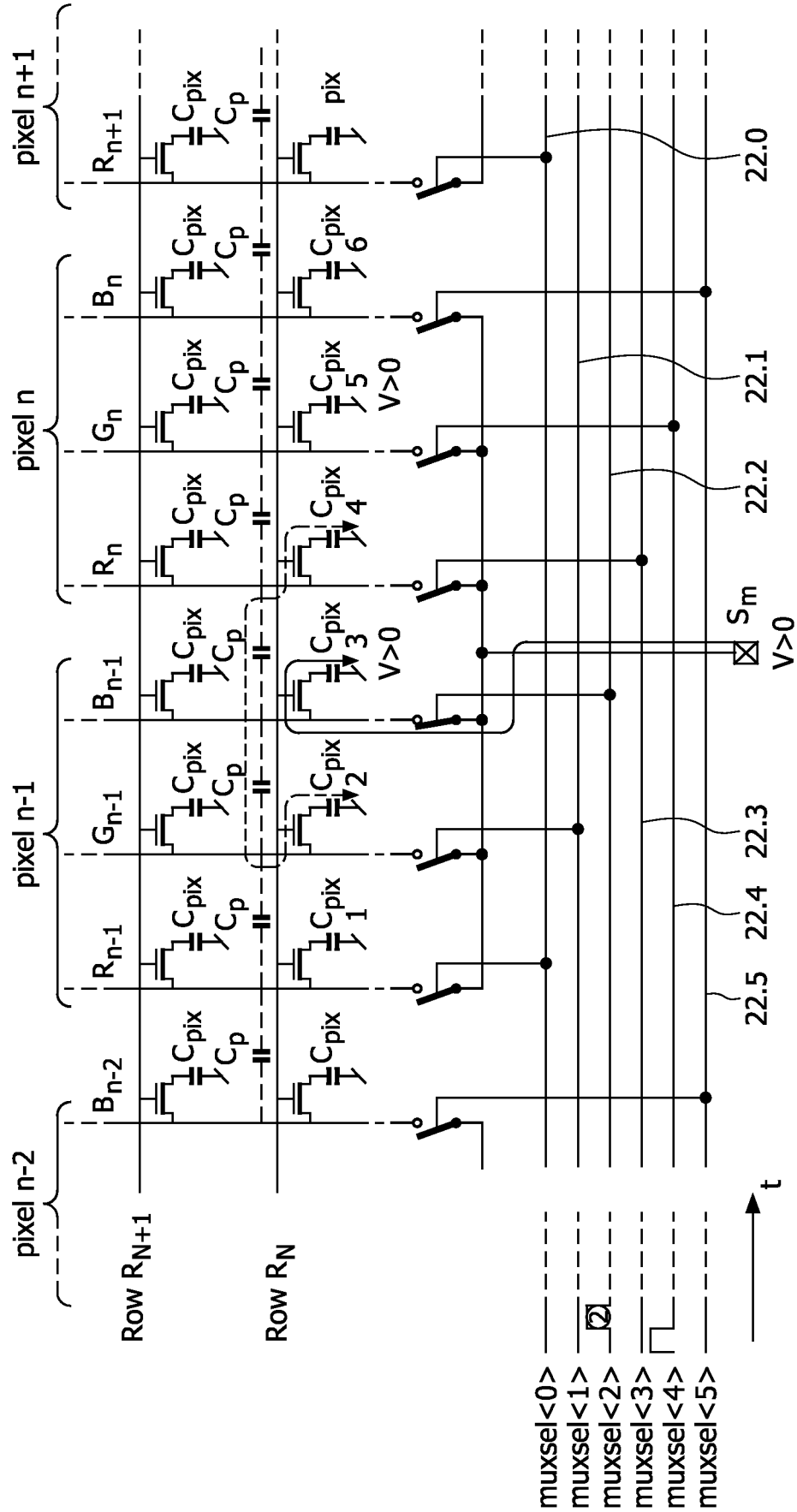

FIG. 8B

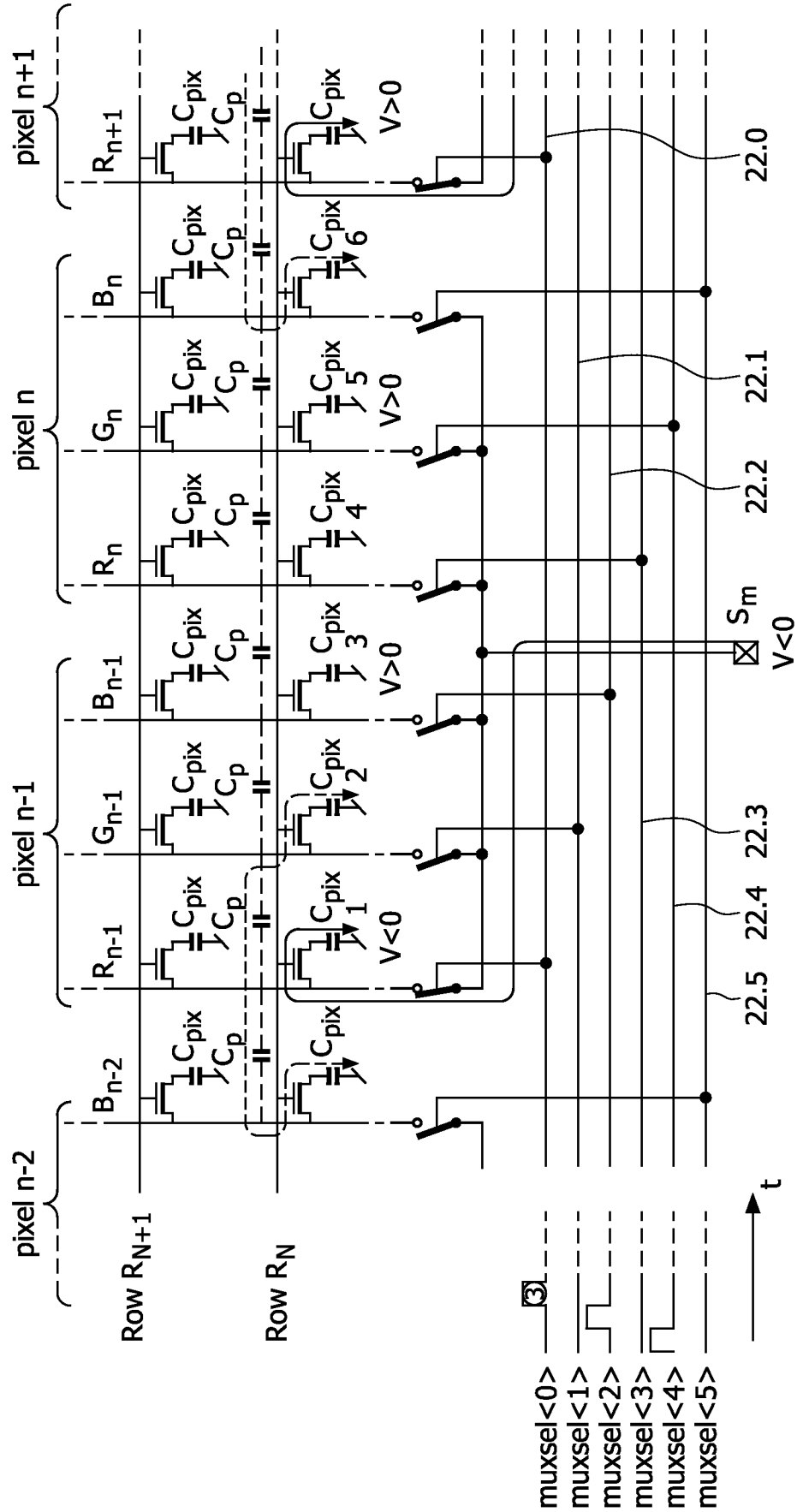

FIG. 8C

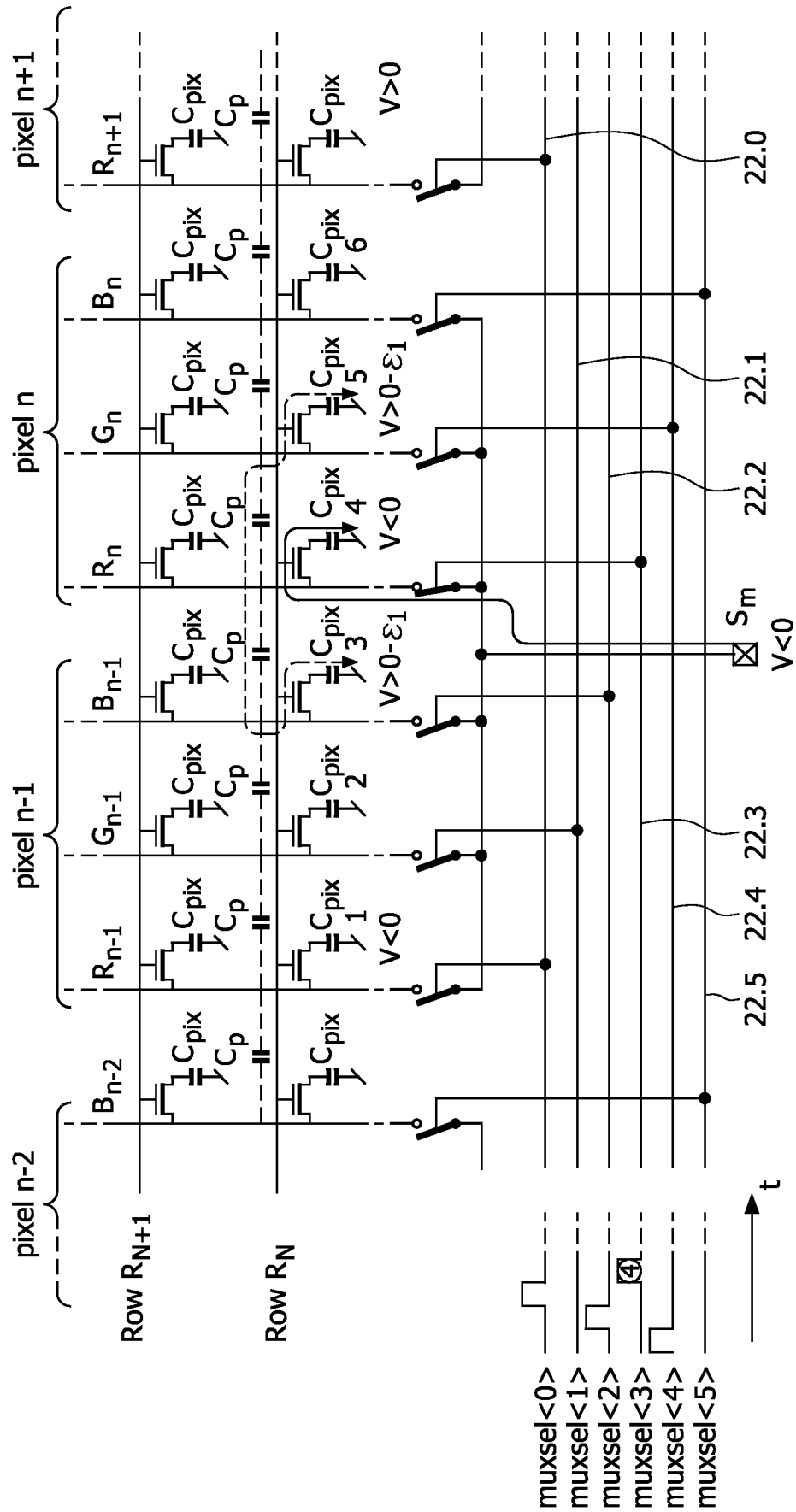

FIG. 8D

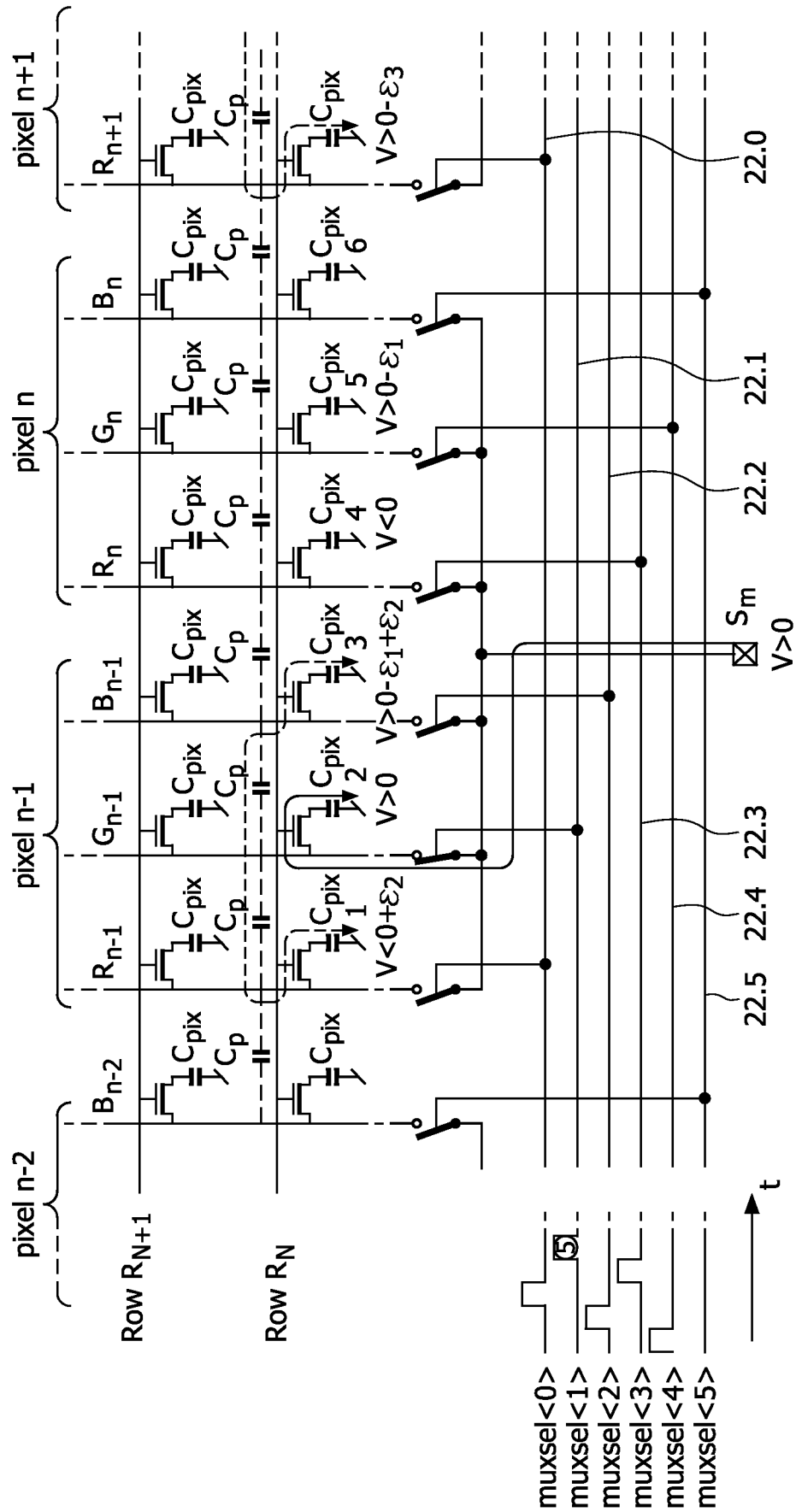

FIG. 8E

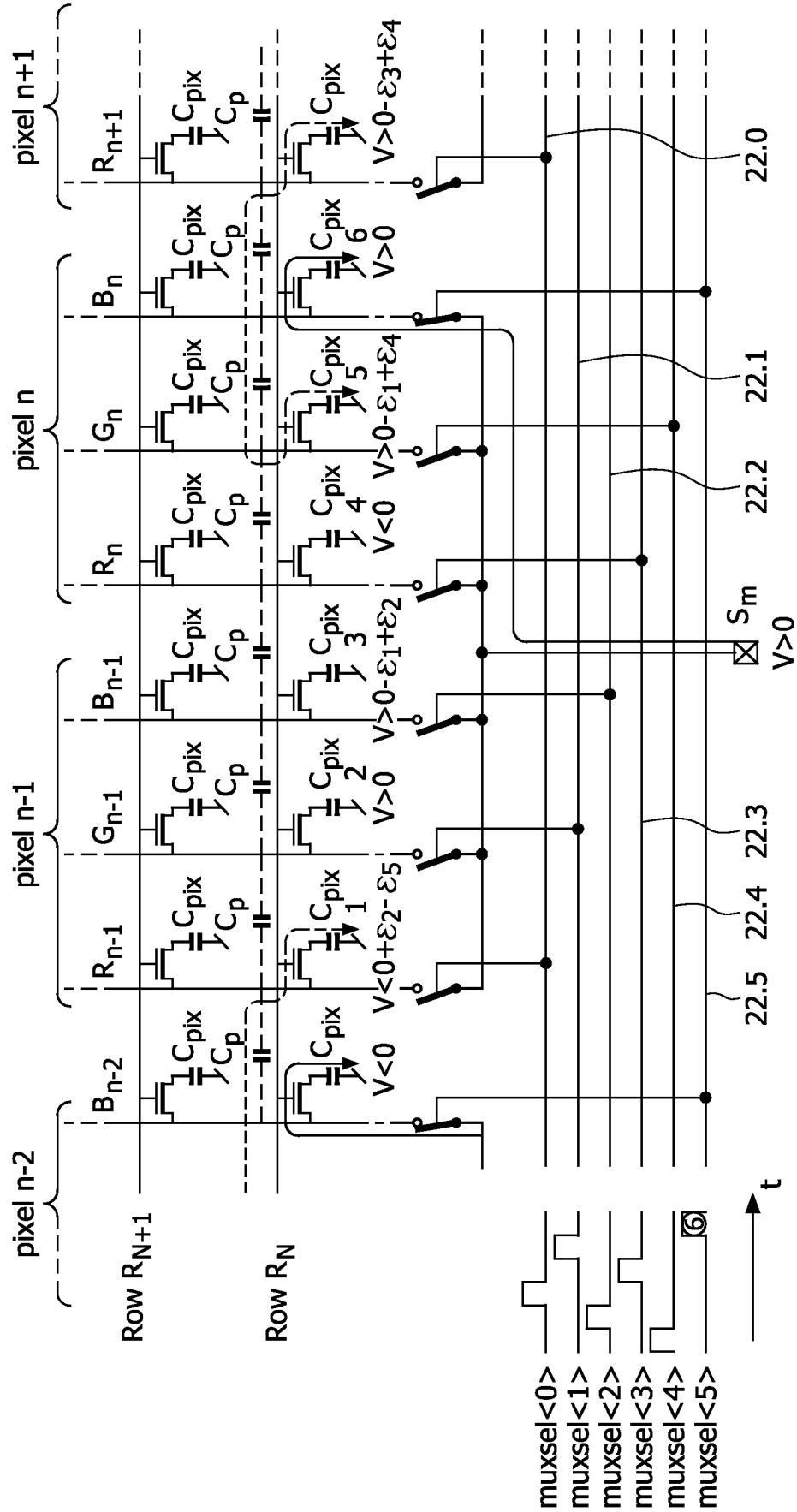

FIG. 8F

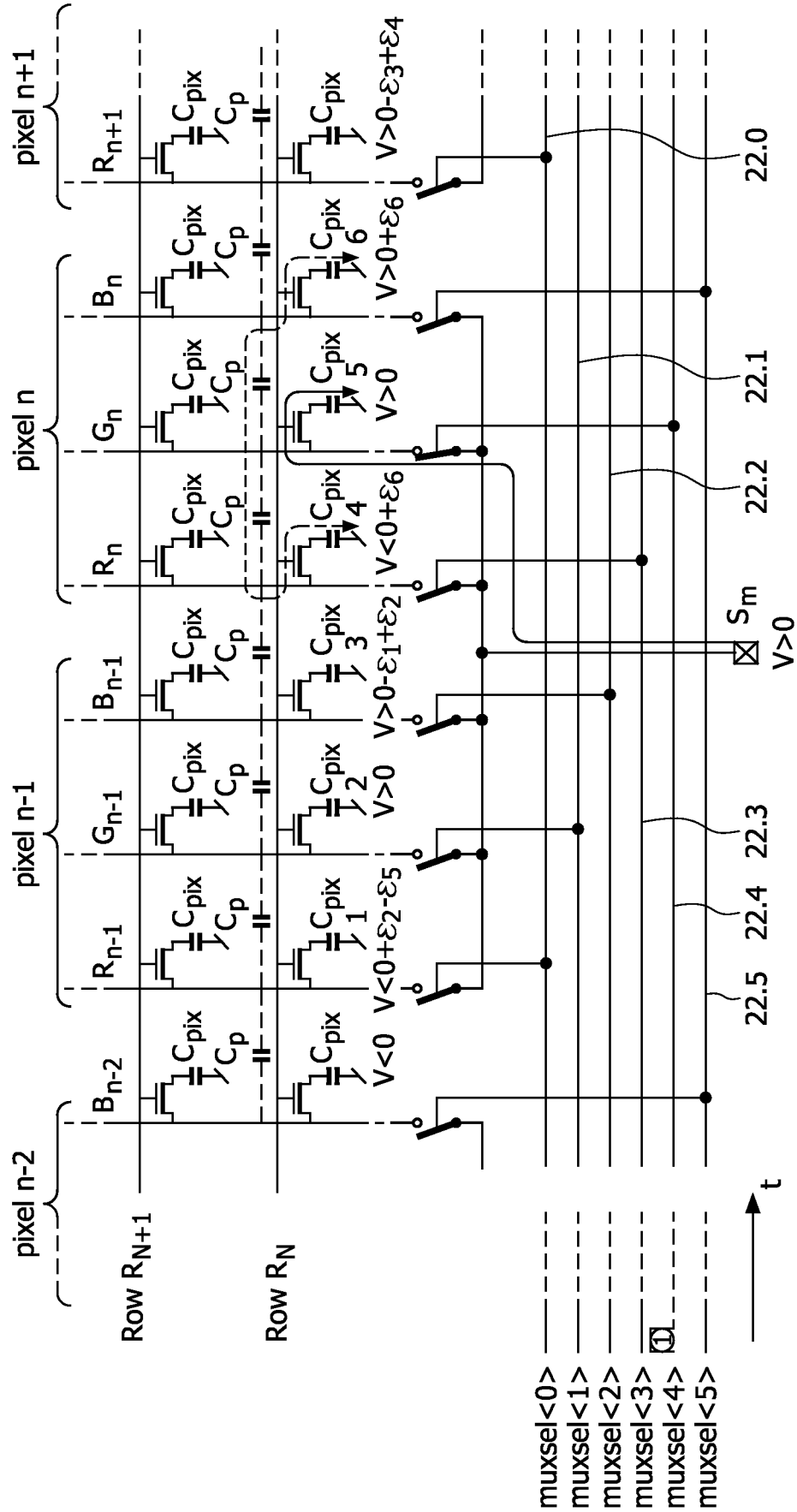

FIG. 9A

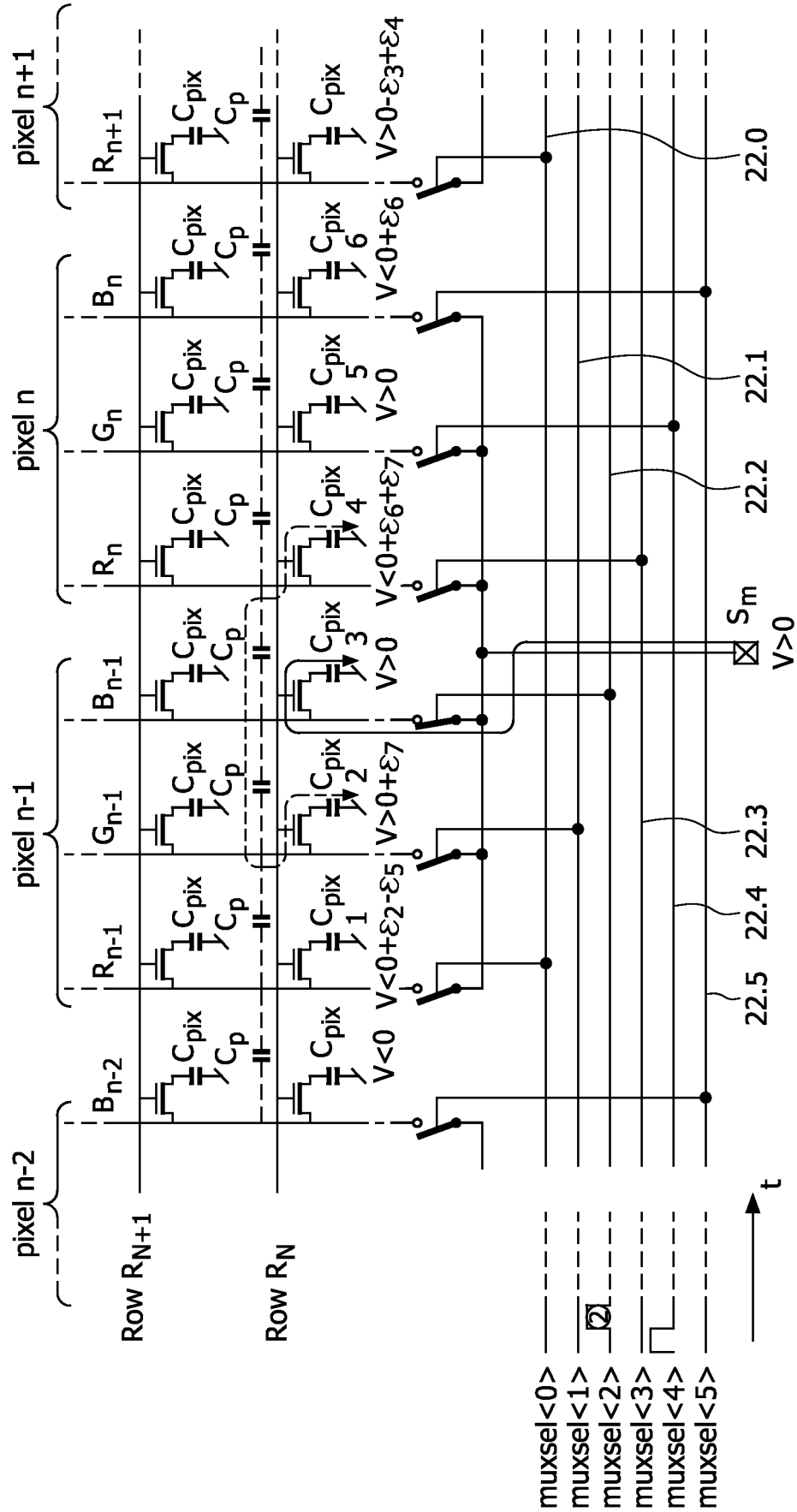

FIG. 9B

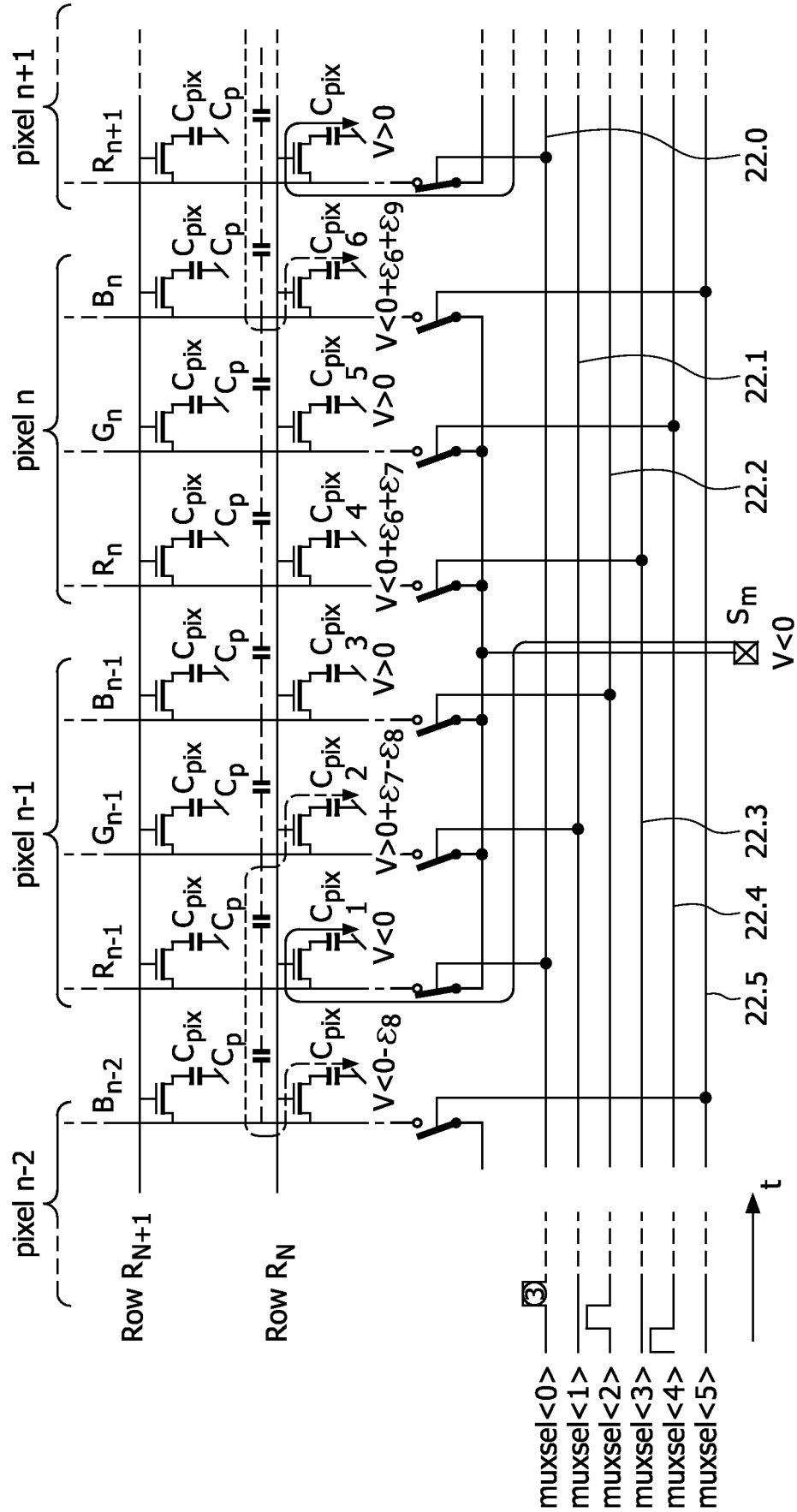

FIG. 9C

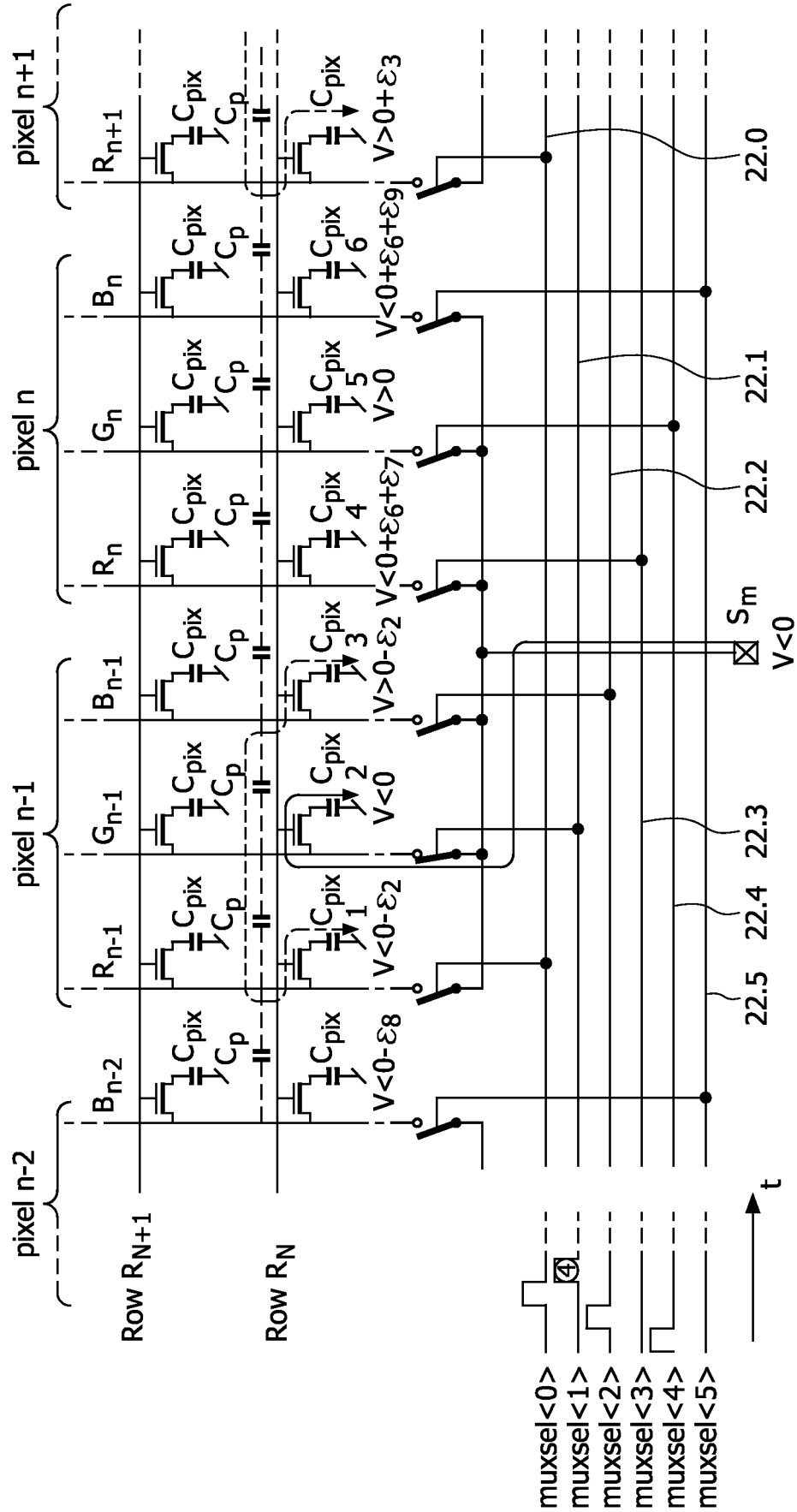

FIG. 9D

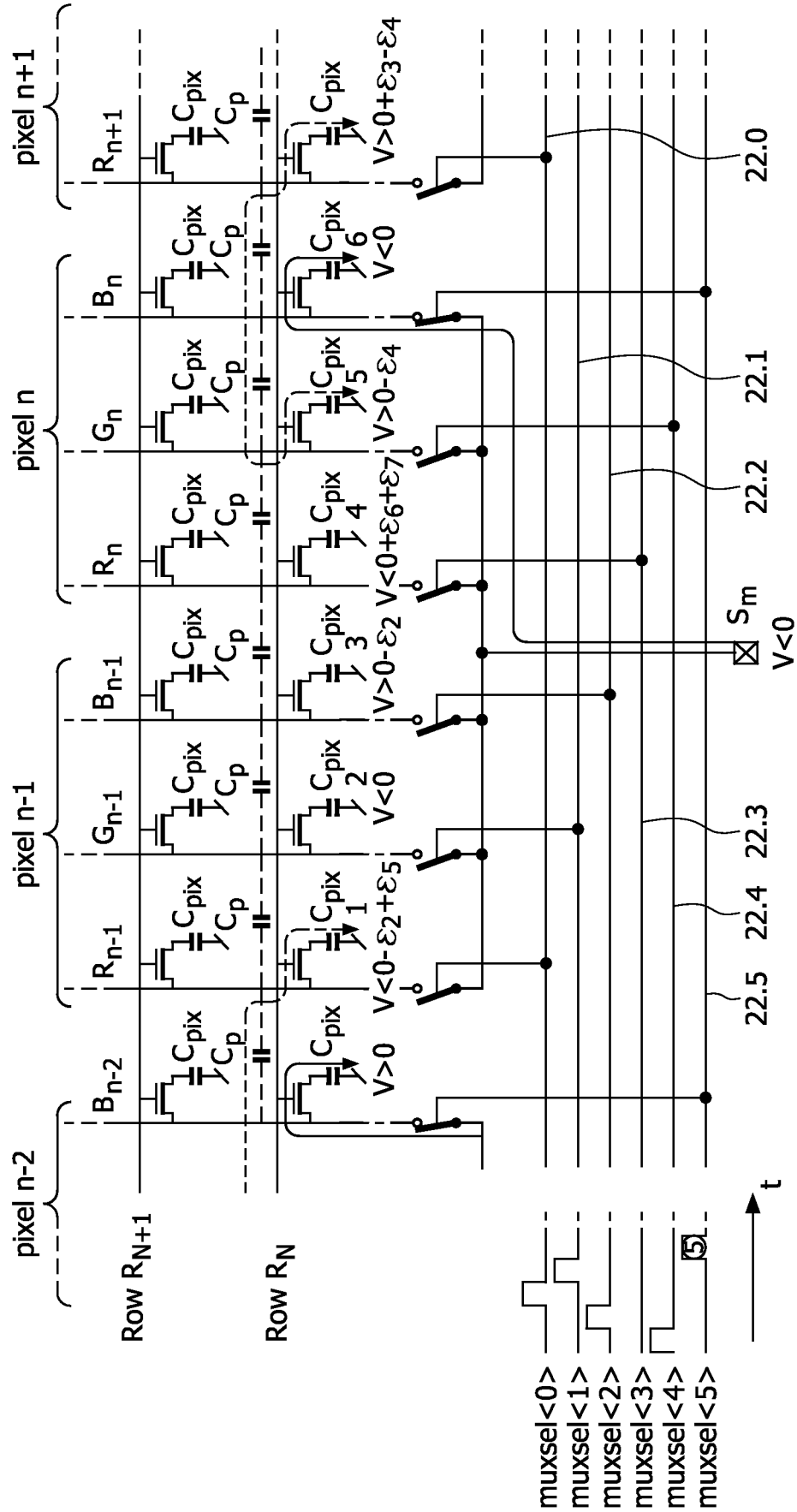

FIG. 9E

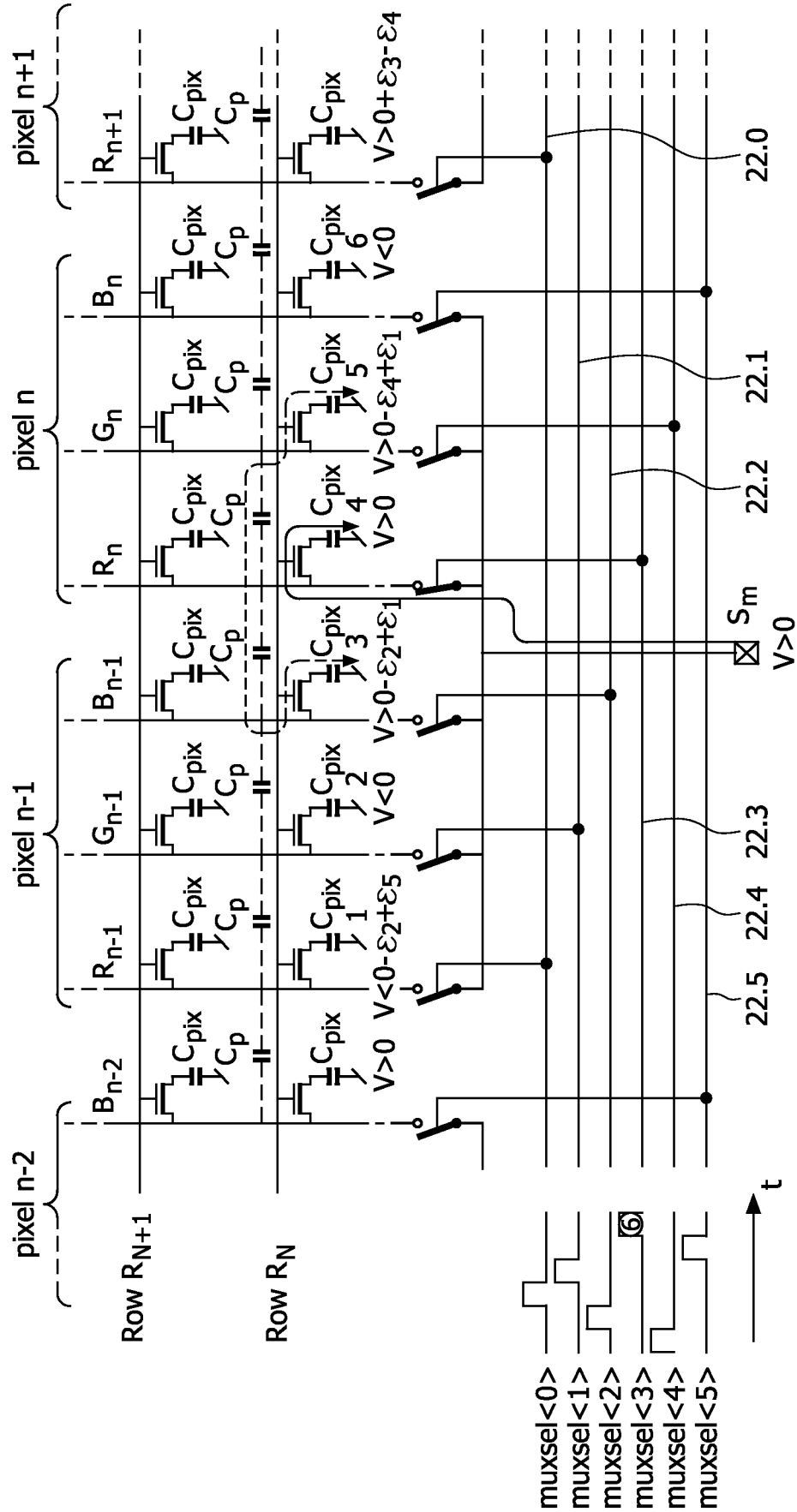

FIG. 9F