



INTERNATIONAL APPLICATION PUBLISHED UNDER THE PATENT COOPERATION TREATY (PCT)

<p>(51) International Patent Classification <sup>6</sup> : <b>A61M 25/00, B29C 55/22, B32B 1/08</b></p>	<p><b>A1</b></p>	<p>(11) International Publication Number: <b>WO 97/32624</b> (43) International Publication Date: 12 September 1997 (12.09.97)</p>
<p>(21) International Application Number: PCT/US97/04061 (22) International Filing Date: 6 March 1997 (06.03.97) (30) Priority Data: 08/611,664 6 March 1996 (06.03.96) US (71) Applicant (for all designated States except US): SCIMED LIFE SYSTEMS, INC. [US/US]; One Scimed Place, Maple Grove, MN 55311-1566 (US). (72) Inventors; and (75) Inventors/Applicants (for US only): WANG, Lixiao [CN/US]; 12822 - 86th Place North, Maple Grove, MN 55369 (US). CHEN, Jianhua [CN/US]; Apartment 207, 6400 67th Avenue North, Brooklyn Park, MN 55428 (US). LEE, Nao [US/US]; 2816 81st Avenue North, Brooklyn Park, MN 55444 (US). (74) Agents: STEINKRAUS, Walter, J. et al.; 1540 Kinnard Financial Center, 920 Second Avenue South, Minneapolis, MN 55402 (US).</p>	<p>(81) Designated States: CA, JP, US, European patent (AT, BE, CH, DE, DK, ES, FI, FR, GB, GR, IE, IT, LU, MC, NL, PT, SE).  <b>Published</b> <i>With international search report. Before the expiration of the time limit for amending the claims and to be republished in the event of the receipt of amendments.</i></p>	

(54) Title: LAMINATE CATHETER BALLOONS WITH ADDITIVE BURST STRENGTH AND METHODS FOR PREPARATION OF SAME

(57) Abstract

A laminated balloon comprising at least two layers of separately oriented thermoplastic polymer material, which are coextensive over the body of the balloon. The two layers may be made of different polymer materials, including an underlying layer made of a low compliant, high strength polymer, such as PET, and an overlying layer of a softer and more flexible polymer material relative to the first polymer material, such as a polyester-polyether block copolymer. The balloon structures have an additive burst pressure, meaning that they are stronger than a signal-layer reference balloon corresponding to the underlying polymer layer. The balloons are characterized by a combination of flexibility and surface softness which allows catheters to track down into lesions relatively easily, puncture resistance, abrasion resistance and refoldability, in addition to low compliance and high burst strength. The balloon may be prepared with generally linear or with stepped compliance profiles. Methods of preparation of such balloons are also disclosed.

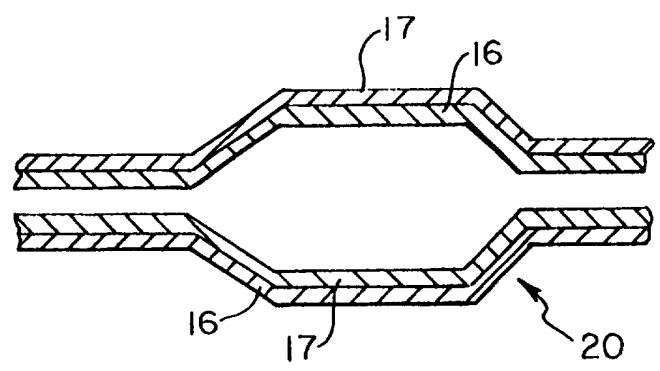

**FOR THE PURPOSES OF INFORMATION ONLY**

Codes used to identify States party to the PCT on the front pages of pamphlets publishing international applications under the PCT.

AM	Armenia	GB	United Kingdom	MW	Malawi
AT	Austria	GE	Georgia	MX	Mexico
AU	Australia	GN	Guinea	NE	Niger
BB	Barbados	GR	Greece	NL	Netherlands
BE	Belgium	HU	Hungary	NO	Norway
BF	Burkina Faso	IE	Ireland	NZ	New Zealand
BG	Bulgaria	IT	Italy	PL	Poland
BJ	Benin	JP	Japan	PT	Portugal
BR	Brazil	KE	Kenya	RO	Romania
BY	Belarus	KG	Kyrgystan	RU	Russian Federation
CA	Canada	KP	Democratic People's Republic of Korea	SD	Sudan
CF	Central African Republic	KR	Republic of Korea	SE	Sweden
CG	Congo	KZ	Kazakhstan	SG	Singapore
CH	Switzerland	LI	Liechtenstein	SI	Slovenia
CI	Côte d'Ivoire	LK	Sri Lanka	SK	Slovakia
CM	Cameroon	LR	Liberia	SN	Senegal
CN	China	LT	Lithuania	SZ	Swaziland
CS	Czechoslovakia	LU	Luxembourg	TD	Chad
CZ	Czech Republic	LV	Latvia	TG	Togo
DE	Germany	MC	Monaco	TJ	Tajikistan
DK	Denmark	MD	Republic of Moldova	TT	Trinidad and Tobago
EE	Estonia	MG	Madagascar	UA	Ukraine
ES	Spain	ML	Mali	UG	Uganda
FI	Finland	MN	Mongolia	US	United States of America
FR	France	MR	Mauritania	UZ	Uzbekistan
GA	Gabon			VN	Viet Nam

## LAMINATE CATHETER BALLOONS WITH ADDITIVE BURST STRENGTH AND METHODS FOR PREPARATION OF SAME

### Background of the Invention

5                   Balloons mounted on the distal ends of catheters are widely used in medical treatment. The balloon may be used to widen a vessel into which the catheter is inserted or to force open a blocked vessel. The requirements for strength and size of the balloons vary widely depending on the balloon's intended use and the vessel size into which the catheter is inserted. Perhaps the most demanding applications for such  
10 balloons are in balloon angioplasty in which catheters are inserted for long distances into extremely small vessels and used to open stenoses of blood vessels by balloon inflation. These applications require extremely thin walled, high strength, relatively inelastic balloons of predictable inflation properties. Thin walls are necessary because the balloon's wall and waist thicknesses limit the minimum diameter of the distal end of the  
15 catheter and therefore determine the limits on vessel size treatable by the method and the ease of passage of the catheter through the vascular system. High strength is necessary because the balloon is used to push open a stenosis and so the thin wall must not burst under the high internal pressures necessary to accomplish this task. The balloon must have some elasticity so that the inflated diameter can be controlled, enabling the surgeon  
20 to vary the balloon's diameter as required to treat individual lesions, but that elasticity must be relatively low so that the diameter is easily controllable. Small variations in pressure must not cause wide variation in diameter.

                  The compliance characteristics of angioplasty balloon materials are described in US 5,447,497, incorporated herein by reference. A variety of low-compliant  
25 materials have been employed in angioplasty balloons, including polypropylene, polyimides, polyamides, and polyesters, such as PET and PEN. Such low compliant materials can generally be fabricated into higher strength balloons than balloons made of more compliant materials. The use of low compliant materials, however, has been associated with a number of minor but undesirable problems, such as poor refold  
30 characteristics, pinhole development, difficulty in bonding to the catheter structure and high friction coefficient.

                  To address some of these problems a number of balloon structures have

been proposed in which a layer of low compliant polymer material is coated or coextruded with an over or underlying layer of another polymer material less prone to one or more of the problems occasionally encountered with low compliant balloons. Exemplary of this approach are US 5,270,086 (Hamlin), US 5,195,969 (J. Wang, et al.) and US 5,290,306 (Trotta, et al), which pertain to co-extruded structures and US 5,490,839 (L. Wang, et. al) which pertains to coated balloon structures wherein the balloon coating imparts refold and soft pliable surface characteristics. The balloons of these references are unitary structures whose compliance and burst profiles are determined primarily by the non-compliant polymer layer, with little or no contribution by the second polymer layer. However, balloons made from coextruded tubes with soft polymer material on the top layer do provide rewrap, abrasion and puncture resistance, and reduced tracking resistance.

It is also known to prepare catheter balloon structures which include two separate concentrically arranged balloon elements mounted on a catheter. References which describe such structures include US 4,608,984, in which an outer balloon element of a highly elastic material such as latex having a deflated circumference less than the diameter of the associated catheter is disclosed for use in refolding the inner working balloon after it has been inflated and deflated; and US 5,447,497, US 5,358,487 and US 5,342,305, in which a non-linear compliance curve is obtained from two different sized balloon elements or from use of an inner balloon which bursts at some pressure below the burst pressure of the outer element. The dual concentric balloon structures, are made of materials of quite different strength characteristics and tend to give balloons whose burst strength is little different from to the burst strength of the strongest member element (typically PET or nylon).

25

### **Summary of the Invention**

This invention will provide a linear and noncompliant balloon expansion curves. In the case both balloons have almost the same diameters.

In one aspect the invention comprises a laminate balloon comprising at least two layers of separately oriented thermoplastic polymer material, which are coextensive over the body of the balloon. The two layers are preferably made of different

30

polymer materials. Suitably, the layers are sufficiently adherent to each other so that the laminate balloon is a unitary structure even when the balloon is deflated. Most preferably the balloon has an underlying layer made of a low compliant, high strength polymer and an overlying layer of a softer and more flexible polymer material relative to the first polymer material. The inventive balloon structures have an additive burst pressure, meaning that they are stronger than a first single-layer reference balloon corresponding to the underlying polymer layer. The additive strength of the balloons of the invention is exhibited typically by burst strengths greater than the first reference balloon by at least 50%, and commonly at least 75%, of the strength of a second single-layer reference balloon corresponding to the overlying relatively soft flexible polymer layer. Optimal balloons of the invention give burst strengths which exceed the strength of the first reference balloon by about 100% or even more of the strength of the second reference balloon.

The preferred inventive balloons have good flexibility and surface softness, allowing catheters to track down into lesions relatively easily, good puncture resistance, good abrasion resistance and good refold characteristics, all contributed by the soft material top layer. Furthermore they also have a low compliance profile with a burst strength which exceeds the strongest PET angioplasty balloons currently commercially available.

A second aspect of the invention comprises a preferred method of making a laminate balloon which includes the steps of

- a) providing a stretched tubing assembly of at least two tubing segments of polymeric material, a first of said tubing segments being formed from a first polymeric material, and a second of said tubing segments being formed from a second polymeric material, the first tubing segment being located within the second tubing segment, the first and second segments each having been formed by extrusion followed by axial stretching at different respective stretch ratios; and
- b) forming the laminate balloon by pressurizing the laminate stretched tubing structure at a temperature and pressure above ambient so as to expand the laminate stretched tubing structure.

A still further aspect of the invention is an alternative process for forming a laminate balloon which includes the steps of:

- a) providing a first tubing segment of a first polymer material;
- 5 b) stretching the first tubing segment at a first stretch ratio to produce a first stretched tube;
- c) blowing the first stretched tube in a mold to produce a first layer structure, said first layer structure including waist, cone and body portions, the waist portion having an inner diameter;
- c) providing a second tubing segment of a second polymer material;
- 10 d) stretching the second tubing segment at a second stretch ratio to produce a second stretched tube having an outer diameter less than the inner diameter of the waist portion of said first layer structure;
- e) inserting the second stretched tube into the first layer structure and
- f) forming the laminate balloon by pressurizing the second stretched tube at  
15 a temperature and pressure above ambient to expand the second layer tube, forming a second layer which is in direct annular contact with the first layer structure.

Balloons of the invention ordinarily have generally linear compliance curves, however, if desired, the balloons can be provided with stepped compliance curves  
20 can be prepared by use of a post-blowing annealing process to shrink the balloon.

Further aspects of the invention will become apparent from the following description, claims and drawings.

### **Brief Description of the Drawings**

25 Figures 1-5 depict various stages in the preferred process for forming a balloon of the invention.

Fig.1 is a side plan view of a portion of an extruded tubing segment for use in forming a first layer of the inventive balloon according to the preferred process of the invention.

30 Fig. 2 is a side plan view of the portion of tubing depicted in Fig. 1 after it has been stretched to form the first stretched tube.

Fig. 3 is a cross-sectional view showing the first stretched tube of Fig. 2 inserted into a second tubing segment.

Fig. 4 is a cross-sectional view as in Fig. 3 after the second tubing segment has been stretched down onto the first stretched tube.

5 Fig. 5 is a side sectional view of a balloon of the invention.

Fig. 6 is a graph of the compliance curve of a balloon prepared in accordance with Example 5.

Fig. 7 is a graph of the compliance curve of a balloon prepared in accordance with Example 8.

10

### Detailed Description of the Preferred Embodiments

In the preferred embodiments the balloon is formed of two layers of different polymer material, one of which is a low compliant, high strength thermoplastic polymer and the other of which is a relatively soft and flexible polymer material.

15 However, other combinations of polymer materials can also be used, including dual layers of the same polymer material. Furthermore, balloons of the invention can also be prepared using more than two laminae without departing from the principles of the invention hereof.

The materials used for strong layer are low compliant, high strength  
20 thermoplastic polymers. Suitably the balloon polymer is poly(ethylene terephthalate) (PET) of initial intrinsic viscosity of at least 0.5, more preferably 0.7-1.3, as reported by the polymer manufacturer. Other high strength polyester materials, such as poly(ethylene naphthalenedicarboxylate) (PEN); polyamides such as nylon 11, nylon 12 and  
25 aromatic/aliphatic polyamides; thermoplastic polyimides; liquid crystal polymers and high strength engineering thermoplastic polyurethanes such as Isoplast 301 sold by Dow Chemical Co., are considered suitable alternative materials. Physical blends and copolymers of such materials may also be used. Examples of thermoplastic polyimides are described in T.L. St. Clair and H.D. Burks, "Thermoplastic/Melt-Processable Polyimides," NASA Conf. Pub. #2334 (1984), pp. 337-355. A suitable thermoplastic  
30 polyimide is described in US 5,096,848 and is available commercially under the tradename Aurum<sup>®</sup> from Mitsui Toatsu Chemicals, Inc., of Tokyo, Japan. Examples of

liquid crystal polymers include the products Vectra<sup>®</sup> from Hoechst Celanese, Rodrun<sup>®</sup> from Unitika, LX or HX series polymers from DuPont and Xydar from Amoco. Suitably the liquid crystal polymer materials are blended with another thermoplastic polymer such as PET.

5           The soft materials used for soft and flexible layer are suitably thermoplastic elastomers, especially segmented polyester/ether block copolymers, such as available under the trademarks Arnitel<sup>®</sup> and Hytrel<sup>®</sup>; flexible polyurethanes, such as sold under the trademark Pellethane<sup>®</sup>; and polyamide/ether block copolymers, such as sold under the Pebax<sup>®</sup> trademark.

10           The preferred balloons of the invention are polyester/polyether segmented block copolymers. Such polymers are made up of at least two polyester and at least two polyether segments.

          The polyether segments of the polyester/polyether segmented block copolymers are aliphatic polyethers having at least 2 and no more than 10 linear saturated  
15 aliphatic carbon atoms between ether linkages. More preferably the ether segments have 4-6 carbons between ether linkages, and most preferably they are poly(tetramethylene ether) segments. Examples of other polyethers which may be employed in place of the preferred tetramethylene ether segments include polyethylene glycol, polypropylene glycol, poly(pentamethylene ether) and poly(hexamethylene ether). The hydrocarbon  
20 portions of the polyether may be optionally branched. An example is the polyether of 2-ethylhexane diol. Generally such branches will contain no more than two carbon atoms. The molecular weight of the polyether segments is suitably between about 400 and 2,500, preferably between 650 and 1000.

          The polyester segments are polyesters of an aromatic dicarboxylic acid  
25 and a two to four carbon diol. Suitable dicarboxylic acids used to prepare the polyester segments of the polyester/polyether block copolymers are ortho-, meta- or para- phthalic acid, naphthalenedicarboxylic acid or meta-terphenyl-4,4'-dicarboxylic acids. Preferred polyester/polyether block copolymers are poly(butylene terephthalate)-*block*-poly(tetramethylene oxide) polymers such as Arnitel EM 740, sold by DSM Engineering  
30 Plastics. Hytrel polymers, sold by DuPont which meet the physical and chemical specifications set out herein can also be used.



It should be noted here that with respect to the block copolymers described herein, the individual polymeric segments which make up the block copolymers are typically of insufficient size to constitute thermoformable materials and in that sense may be considered oligomers. Thus, even those block copolymers which  
 5 contain blocks of the same structural type as the strong layer material used in the inventive balloons are very different, non-equivalent, materials from those strong layer materials.

Polyamide/polyether block copolymers may also be used as the soft layer polymer. The polyamide/polyether block copolymers are commonly identified by the  
 10 acronym PEBA (polyether-*block*-amide). The polyamide and polyether segments of these block copolymers may be linked through amide linkages, however, most preferred are ester linked segmented polymers, *i.e.* polyamide/polyether polyesters. Such polyamide/polyether/ polyester block copolymers are made by a molten state polycondensation reaction of a dicarboxylic polyamide and a polyether diol. The result is  
 15 a short chain polyester made up of blocks of polyamide and polyether. The polyamide and polyether blocks are not miscible. Thus the materials are characterized by a two phase structure: one is a thermoplastic region that is primarily polyamide and the other is elastomer region that is rich in polyether. The polyamide segments are semicrystalline at room temperature. The generalized chemical formula for these polyester polymers may  
 20 be represented by the following formula:

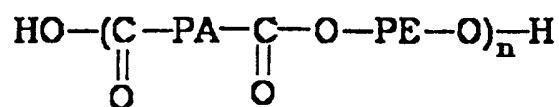

in which PA is a polyamide segment, PE is a polyether segment and the repeating number  $n$  is between 5 and 10.

The polyamide segments are suitably aliphatic polyamides, such as polyamides 12, 11, 9, 6, 6/12, 6/11, 6/9, or 6/6. Most preferably they are polyamide12  
 25 segments. The polyamide segments may also be based on aromatic polyamides but in such case significantly lower compliance characteristics are to be expected. The polyamide segments are relatively low molecular weight, generally within the range of

500-8,000, more preferably 2,000-6,000, most preferably about 3,000-5,000.

The polyether segments are the same as previously described for the polyester/polyether segmented block copolymers block copolymers useful in the invention.

5 The weight ratio of polyamide to polyether in the polyamide/polyether polyesters used in the invention desirably should be in the range of 50/50 to 95/5, preferably between 60/30 and 95/5, more preferably, between 70/30 and 92/8.

Polyamide/polyether polyesters are sold commercially under the Pebax<sup>®</sup> trademark by Atochem North America, Inc., Philadelphia PA. Examples of suitable commercially available polymers are the Pebax<sup>®</sup> 33 series polymers with hardness 60 and above, Shore D scale, especially Pebax<sup>®</sup> 7233, 7033 and 6333. These polymers are made up of nylon 12 segments and poly(tetramethylene ether) segments in different weight ratios and segment lengths.

15 It is also possible to use other PEBA polymers with the physical properties specified herein and obtain similar compliance, strength and softness characteristics in the finished balloon.

It is preferred that the block copolymers have a hardness, Shore D scale, of at least 60 and a flexural modulus of no more than about 150,000, in order to obtain optimal strength, compliance and softness characteristics. Preferably the Shore D 20 hardness is in the range of 65-75 and the flexural modulus is in the range of 50,000-120,000. The preferred polymers useful in the invention are also characterized by a high ultimate elongation of about 300% or higher and an ultimate tensile strength of at least 6,000 psi

25 One process of forming balloons of the invention will be described with reference to Figures 1-5.

Referring to Fig.1 there is shown an extruded tubing segment 12, preferably made of a strong non-compliant material, such as PET. The tubing segment 12 is stretched longitudinally, typically at an elevated temperature, in conventional manner for PET balloons to produce an elongated stretched tube 13 shown in Fig. 2.. 30 The stretch ratio is one which will provide good strength properties in the blown balloon. A typical stretch ratio for a PET material is about 1.5-6 times the length of the original

extruded length. An extruded segment 14 of the second polymer material, suitably a polyester/polyether block copolymer, is then provided having an ID greater than the OD of stretched tube 13. Tube 13 is inserted into tube 14 as shown in Fig. 3. Preferably without further stretching of the tube 13, tube 14 is stretched to produce a second  
5 stretched tube 15 whose ID is necked down, bringing tube 15 into direct contact with tube 13, as shown in Fig 4. For the preferred embodiment a "cold-neck" (*i.e.* at or below ambient temperature) stretch at a ratio of 3-6 may be employed for this step. The composite tubing structure shown in Fig. 4 is then blown at elevated pressure in a manner conventional for single layer balloons, for instance by a process as described in WO  
10 95/22367. The resulting laminate balloon 20, depicted in Fig 5 has two intimately contacting layers, the inner layer 16 being PET and the outer layer 17 being the polyester/polyether block copolymer material. Although they can easily be peeled apart when the balloon is dissected, layers 16 and 17 are sufficiently adherent that the balloon 20 is a unitary structure even when the balloon is deflated and wrapped onto a catheter.

15 By this process, and unlike balloons formed from coextruded tubing, the layers 16 and 17 of balloon 20 have been formed with separate stretch ratios applied to the tubes 12 and 14 so that optimal strength properties can be obtained from both layers.

Multi-laminate balloon structures having three or more laminae can be prepared, for instance, by the additional steps of inserting a composite tubing structure of  
20 Fig. 4 into a third extruded tube which is necked down onto the outer surface of stretched tube 15 before performing the balloon blowing step. Structures with higher numbers of laminae can be prepared by repetition of these additional steps before blowing the balloon. With such multi-layer laminates it may be desirable to further stretch the composite structure of Fig. 4 or any successive composite stretched tubing structure to  
25 reduce the thickness of the composite to be blown and achieve a desired hoop expansion ratio.

Alternative, processes for forming a balloon of the invention are is illustrated in Examples 9-11.

30 After being blown, the dual element balloon of the invention may be provided with a stepped compliance curve by annealing the balloon for a short time after blowing at a pressure at or only slightly above ambient and at a temperature which causes

the blown balloon to shrink. The process is described in US 5,348,538. However, the balloons of the invention are desirably constructed with a greater difference between the low pressure and high pressure linear regions of the compliance curve so that the transition between the two regions results in a step-up of diameter of the balloon of at least 0.4 mm. This is accomplished by blowing the balloon to the larger diameter and then shrinking to a greater extent than was done in the specific illustrative examples of US 5,348,538. The amount of shrinkage is controlled by the pressure maintained in the balloon during annealing and the temperature and time of the annealing. The annealing pressure is suitably in the range of 0-20, preferably 5-10 psi at 70-100°C for 3 seconds to 3 hours.

The invention is illustrated by the following non-limiting examples.

#### Example 1

A PET tube was extruded with an inner diameter of 0.0136 inch and an outer diameter of 0.0288 inch from Traytuf 7357 (Shell Chemical, Akron) PET resin. The PET tube was stretched to 2.25 x its original length (2.25 stretch ratio) at 90°C. The stretched tube was then inserted into a tube of extruded polyester-polyether block copolymer resin (Arnitel EM 740, DSM Engineering Plastics, Evansville IN) of 0.0260 inch ID and 0.0340 inch OD. The polyester-polyether resin tube was cold necked (stretched at ambient temperature) at 4.0 stretch ratio over the PET tube, without further stretching of the PET tube. The resulting coaxially arranged tube assembly was then inserted into a 3.0 mm balloon mold and blown. The mold temperature was 97°C and the blowing pressure was 350 psi with 30 gms tension applied during the blowing process. The measured balloon double wall thickness (*i.e.* two layers of PET and two layers of polyester-polyether) was 0.00145 inch, corresponding to a single wall thickness (one layer each of PET and polyester-polyether) of 0.00073 inch. The compliance curve showed balloon growth from 8 to 18 atm of 2.6%, and 6.25% from 8 to 28 atm. The balloon burst pressure was 529 psi (36 atm). When the balloons prepared in this manner were dissected, the double wall thickness of the PET element was 0.00085 inch and of the polyester-polyether element was 0.0006 inch.

Example 2 (Reference example)

An extruded tube of the same Arnitel EM 740 polyester/polyether resin with the same dimension used in Example 1 was made into a single layer balloon having a double wall thickness 0.0006 inch by stretching and blowing the balloon under similar conditions to those of Example 1. The burst pressure of this balloon was 147 psi (10 atm).

#### Example 3 (Reference example)

A PET tube with the same dimension as used in Example 1 was made into a single layer balloon having a double wall thickness of 0.00085 inch by stretching and blowing under similar conditions as in Example 1. The burst pressure of this balloon was 338 psi. (23 atm).

Comparison of the burst strengths of the two reference balloons produced in Examples 2 and 3 with the burst strength of the inventive balloon of Example 1 shows that the strength of the inventive balloon was more than the sum of the strengths of the two reference balloons.

#### Example 4

A PET tube was extruded with an inner diameter of 0.0134 inch and an outer diameter of 0.0325 inch from Traytuf 7357 PET resin. The PET tube was stretched at a 2.25 stretch ratio at 90°C. The stretched tube was then inserted into a tube of extruded Arnitel EM 740 polyester-polyether block copolymer resin. The extruded tube had dimensions of 0.0245 inch ID and 0.0405 inch OD. The polyester-polyether resin tube was stretched at ambient temperature at 4.0 stretch ratio over the PET tube, without further stretching of the PET tube. The resulting coaxially arranged tube assembly was then inserted into a balloon 3.0 mm mold and blown. The mold temperature was 97°C and the blowing pressure was 460 psi with 150 gms tension applied during the blowing process. The measured balloon double wall thickness was 0.0016 inch, corresponding to a single wall thickness (one layer each of PET and polyester-polyether) of 0.0008 inch. The compliance curve showed balloon growth from 8 to 18 atm of 4%, and 9% from 8 to 28 atm. The balloon burst pressure was 426 psi (29 atm). When similarly prepared balloons were dissected, the double wall thickness of the PET element was 0.0009 inch and of the polyester-polyether element was 0.0008 inch.

## Example 5

A PET tube was extruded with an inner diameter of 0.0147 inch and an outer diameter of 0.0291 inch from Traytuf 7357 PET resin. The PET tube was stretched at a 2.25 stretch ratio at 90°C. The stretched tube was then inserted into a tube of  
5 extruded Arnitel EM 740 polyester-polyether block copolymer resin. The extruded tube had dimensions of 0.026 inch ID and 0.043 inch OD. The polyester-polyether resin tube was stretched at ambient temperature at 4.0 stretch ratio over the PET tube, without further stretching of the PET tube. The resulting coaxially arranged tube assembly was then inserted into a balloon 3.25 mm mold and blown. The mold temperature was 97°C  
10 and the blowing pressure was 500 psi with 600 gms tension applied during the blowing process. The measured balloon double wall thickness was 0.0022 inch. The PET layer double wall thickness was 0.0012 inch and the Arnitel layer double wall thickness was 0.0010 inch. The compliance curve showed balloon growth from 8 to 18 atm of 3%, and 5% from 8 to 28 atm. The balloon burst pressure was 573 psi (39 atm). The compliance  
15 curve for this balloon is shown in Fig 6.

## Example 6 (Reference example)

A tube of Arnitel EM 740 resin with the same dimensions as example 2 was made into a single balloon with double wall thickness 0.0007 inch. The burst  
20 pressure of the resulting balloon was 221 psi (15 atm).

## Example 7 (Reference example)

A PET tube with the same dimensions as example 3 was made into a single layer balloon with double wall thickness 0.0008 inch. The burst pressure was 330  
psi (22 atm).

## Example 8

A PET tube of 0.0147 inch ID and 0.0275 inch OD was extruded from  
25 Traytuf 7357 PET resin. The PET tube was stretched at a 2.25 ratio at 90°C. The stretched tube was then inserted into a tube of extruded Arnitel EM 740 resin. Then, the Arnitel tube was stretched at ambient temperature over the PET tube at a 4.0 stretch ratio, without further stretching the PET tube. The combined tube was then inserted into a  
30 mold with body dimension of 3.0 mm. The mold process was similar to that described in WO95/22367, using a mold temperature of 97°C and blowing pressure/tension settings

(psi/gms) of 530/40, 150/40 and 580/100, respectively, to blow the proximal, body and distal portions of the balloon respectively. The balloon was then shrunk by annealing at 82°C for 2 hours at 5 psi inflation pressure. The balloon double wall thickness was 0.0018 inch. The balloon had a hybrid or step compliance curve as demonstrated in Fig. 7. The average balloon burst pressure for 3 balloons prepared in this manner was 417 psi (28.5 atm).

#### Example 9

This example illustrates an alternative laminate balloon blowing procedure of the invention and produces a balloon in which the soft flexible polymer is the under layer.

Extruded tubes of PET having dimensions of 0.0136 inch ID and 0.0288 inch OD and Arnitel EM 740 having dimensions of 0.0210 inch ID and 0.0370 inch OD were used in this example. Single layer PET balloons were prepared by stretching the PET tubes at 2.25 stretch ratio and then blowing the stretched tubes in a 2.8 mm mold using a mold temperature of 97°C and blowing pressure/tension settings (psi/gms) of 210/20, 100/20 and 210/20, respectively, to blow the proximal, body and distal portions of the balloons respectively. The Arnitel EM 740 tubes were stretched at ambient temperature at a 4.0 stretch ratio and each inserted into a PET balloon, still in the mold. The Arnitel tubing was blown at 80°C and 400 psi pressure without applying tension, yielding laminate balloons which had an average double wall thickness of 0.0023 inch and an average burst pressure of 398 psi (27 atm).

#### Example 10

A PET tube 0.0171 inch ID and 0.0330 inch OD was extruded from Shell Cleartuf® 8006. The PET tube was stretched at a ratio of 2.25x at 98°C. The stretched tube was then inserted into a pre-stretched tube of DuPont Hytrel® 7246. The Hytrel tube had been extruded to a dimension of 0.0440 inch ID and 0.054 inch OD and stretched at 60°C at a 4.5 ratio. The combined tubing assembly was then inserted into a mold for a 3.5 mm balloon. Inflation pressure of 350 psi was applied to the inner tube while the mold was heated to 98.5°C and tension of 40 grams was applied to the tubing assembly. The resulting balloon had a double wall thickness of 0.00148 inch. Compliance at 8-18 atm was 2.6% and from 8-26 atm was 5.5%. The balloon pressure was 467 psi (31.7

atm).

#### Example 11

A PET tube 0.0195 inch ID and 0.0351 inch OD was extruded from Shell Cleartuf<sup>®</sup> 8006. The PET tube was stretched at a ratio of 2.25x at 90°C. The stretched  
5 tube was then inserted into a pre-stretched tube of DuPont Hytrel<sup>®</sup> 7246. The Hytrel tube had been extruded to a dimension of 0.045 inch ID and 0.051 inch OD and stretched at 60°C at a 3.5 ratio. The combined tubing assembly was then inserted into a mold for a 3.0 mm balloon. Inflation pressure of 325 psi was applied to the inner tube while the mold was heated to 98.5°C and tension of 60 grams was applied to the tubing assembly.  
10 The resulting balloon had a double wall thickness of 0.00130 inch. Compliance at 6-12 atm was 6% and from 8-18 atm was 16%. The balloon pressure was 300 psi (20.5 atm).

Balloons of the invention may be prepared for use on medical devices in various interventional medical specialties including cardiology, gastroenterology,  
15 pulmonary medicine, radiology, urology and vascular surgery. Examples of useful applications include catheters used in coronary and vascular percutaneous transluminal angioplasty, catheters used for ultrasound or laser imaging systems, catheters used to deliver and implant vascular prostheses, devices used to diagnose and treat gastrointestinal disorders, biliary interventional products used in endoscopic procedures  
20 in the gall bladder and bile ducts, and prostrate dilatation catheters. Depending on the particular application, the balloons may be prepared with a wide range of inflated diameters, typically in the range of 1 mm to about 30 mm, and more typically 1.5 mm to about 20 mm, with typical lengths ranging from 5 mm to about 100 mm.

Although the present invention has been described in terms of specific  
25 embodiments, it is anticipated that alterations and modifications thereof will no doubt be come apparent to those skilled in the art. It is therefore intended that the following claims be interpreted as covering all such alterations and modifications as fall within the true spirit and scope of the invention.



**Claims**

What is claimed is:

1. A process for producing a laminate balloon for mounting on an a catheter, the process comprising the steps of:
  - 5 a) providing a stretched tubing assembly of at least two tubing segments of polymeric material, a first of said tubing segments being formed from a first polymeric material, and a second of said tubing segments being formed from a second polymeric material, the first tubing segment being located within the second tubing segment, the first and second segments each having  
10 been formed by extrusion followed by axial stretching at different respective stretch ratios; and
  - b) forming the laminate balloon by pressurizing the stretched tubing assembly at a temperature and pressure above ambient so as to expand the stretched tubing assembly into a balloon.
- 15 2. A process as in claim 1 wherein the first and second polymer materials are different.
3. A process as in claim 2 wherein the first polymer material is a low compliant, high strength polymer and the second polymer is a softer and more flexible polymer material relative to the first polymer material.
- 20 4. A process as in claim 3 wherein the first polymer material is selected from the group consisting of polyesters, polyamides, thermoplastic polyimides, liquid crystal polymers and high strength engineering thermoplastic polyurethanes and the second polymer material is a thermoplastic elastomer.
5. A process as in claim 4 wherein said thermoplastic elastomer is a  
25 polyester/polyether segmented block copolymer.
6. A process as in claim 1 wherein said step a) comprises the steps of:
  - i) providing a first tubing segment of a first polymer material;
  - ii) stretching the first tubing segment at a first stretch ratio to produce a first stretched tube having an outer diameter;
  - 30 iii) providing a second tubing segment of a second polymer material having an inner diameter greater than the outer diameter of the first stretched

tube;

- iv) inserting the first stretched tube into the second tubing segment; and
- v) stretching the second tubing segment at a second stretch ratio to produce a second stretched tube, the first and second stretched tubes being brought into direct annular contact during the stretching of said second tubing segment, to form said stretched tubing assembly.

5

7. A process as in claim 1 wherein said step a) comprises the steps of:

- i) providing a first tubing segment of a first polymer material;
- ii) stretching the first tubing segment at a first stretch ratio to produce a first stretched tube having an outer diameter;
- iii) providing a second tubing segment of a second polymer material;
- iv) stretching the second tubing segment at a second stretch ratio to produce a second stretched tube having an inner diameter which is not less than the outer diameter of the first stretched tubing segment; and
- v) inserting the first stretched tube into the second stretched tubing segment.

10

15

8. A process as in any previous claim wherein in said balloon forming step (b) said stretched tubing assembly is expanded to a preselected diameter.

9. A process as in claim 8 wherein said balloon forming step (b) is performed in a mold.

20

10. A process as in claim 8 wherein said first and second stretch ratios are individually selected to produce in said laminate balloon at least one preselected strength or compliance characteristic.

25

11. A process as in claim 10 wherein said first polymer material is a low compliant, high strength polymer, said second polymer is a softer and more flexible polymer material relative to the first polymer material, whereby said laminate balloon comprises an underlayer of said first polymer and an overlayer of said second polymer material, said at least one preselected characteristic includes a laminate balloon burst strength value greater than the burst strength of a first reference balloon of said first polymer formed at a wall thickness, a stretch ratio and a hoop expansion ratio

30

substantially the same as the wall thickness, stretch ratio and hoop expansion ratio of said laminate balloon underlayer.

12. A process as in claim 11 wherein said laminate balloon burst strength value exceeds the burst strength of the first reference balloon by an amount which is at least 50% of the burst strength of a second reference balloon of said second polymer formed at a wall thickness, a stretch ratio and a hoop expansion ratio substantially the same as the wall thickness, stretch ratio and hoop expansion ratio of said laminate balloon overlayer.
13. A process as in claim 12 wherein said laminate balloon burst strength value exceeds the burst strength of said first reference balloon by an amount which is at least 75% of the burst strength of said second reference balloon.
14. A laminate balloon produced by the process of claim 1.
15. A laminate balloon produced by the process of claim 11.
16. A laminate balloon comprising at least two layers of separately oriented thermoplastic polymer material, which are coextensive over the body of the balloon when the balloon is at rest.
17. A laminate balloon as in claim 16 wherein said two layers are made of different polymer materials.
18. A laminate balloon as in claim 17 wherein a first of said polymer materials is a low compliant, high strength polymer and a second of said polymer materials is a softer and more flexible polymer material relative to the first polymer material.
19. A laminate balloon as in claim 18 comprising a first layer of said first polymer material and an adjacent second layer of said second polymer material.
20. A laminate balloon as in claim 19 having a central axis, said second layer being located outwardly from said central axis relative to said first layer.
21. A laminate as in claim 19 wherein said second layer defines the outer surface of the balloon.
22. A laminate balloon as in any of claims 18-21 wherein the first polymer material is selected from the group consisting of polyesters, polyamides, thermoplastic polyimides, liquid crystal polymers and high strength engineering thermoplastic polyurethanes and the second polymer material is a thermoplastic elastomer.
23. A laminate balloon as in claim 22 wherein said thermoplastic elastomer is

a polyester/polyether segmented block copolymer.

24. A laminate balloon as in claim 19 wherein said balloon has a burst strength value greater than the burst strength of a first reference balloon of said first polymer formed at a wall thickness, a stretch ratio and a hoop expansion ratio

5 substantially the same as the wall thickness, stretch ratio and hoop expansion ratio of said first layer.

25. A laminate balloon as in claim 24 wherein said laminate balloon burst strength value exceeds the burst strength of the first reference balloon by an amount which is at least 50% of the burst strength of a second reference balloon of said second polymer formed at a wall thickness, a stretch ratio and a hoop expansion ratio

10 substantially the same as the wall thickness, stretch ratio and hoop expansion ratio of said second layer.

26. A laminate balloon as in claim 25 wherein said laminate balloon burst strength value exceeds the burst strength of said first reference balloon by an amount which is at least 75% of the burst strength of said second reference balloon.

15 27. A laminate balloon as in claim 16 wherein at least two of said layers are made of the same polymer material.

28. A laminate balloon as in claim 16 wherein said layers are sufficiently adherent to each other so that the balloon maintains a unitary structure at rest.

20 29. A laminate balloon as in claim 16 having a generally linear compliance curve.

30. A laminate balloon as in claim 16 having a stepped compliance curve.

31. A laminate balloon as in claim 16 wherein the balloon has a wall strength which is greater than each of said layers individually.

25 32. A process for forming a laminate balloon which includes the steps of:

- a) providing a first tubing segment of a first polymer material;
- b) stretching the first tubing segment at a first stretch ratio to produce a first stretched tube;

30 c) blowing the first stretched tube in a mold to produce a first layer structure, said first layer structure including waist, cone and body portions, the waist portion having an inner diameter;

- c) providing a second tubing segment of a second polymer material;
- d) stretching the second tubing segment at a second stretch ratio to produce a second stretched tube having an outer diameter less than the inner diameter of the waist portion of said first layer structure;
- 5 e) inserting the second stretched tube into the first layer structure and
- f) forming the laminate balloon by pressurizing the second stretched tube at a temperature and pressure above ambient to expand the second layer tube, forming a second layer which is in direct annular contact with the first layer structure.

**Fig. 1**



**Fig. 2**



**Fig. 3**

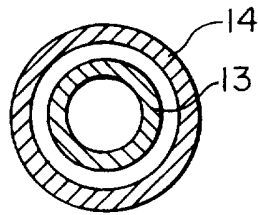

**Fig. 4**

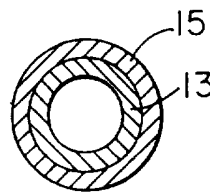

**Fig. 5**

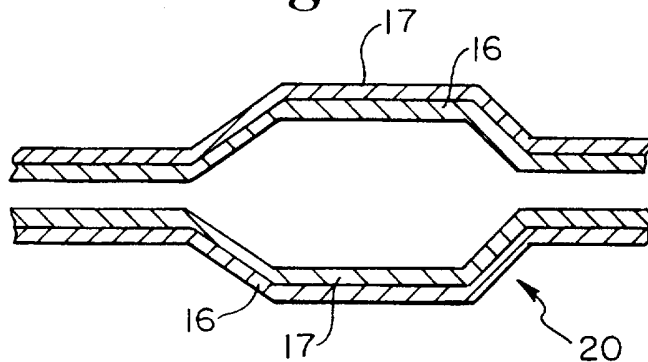

*Fig.6*

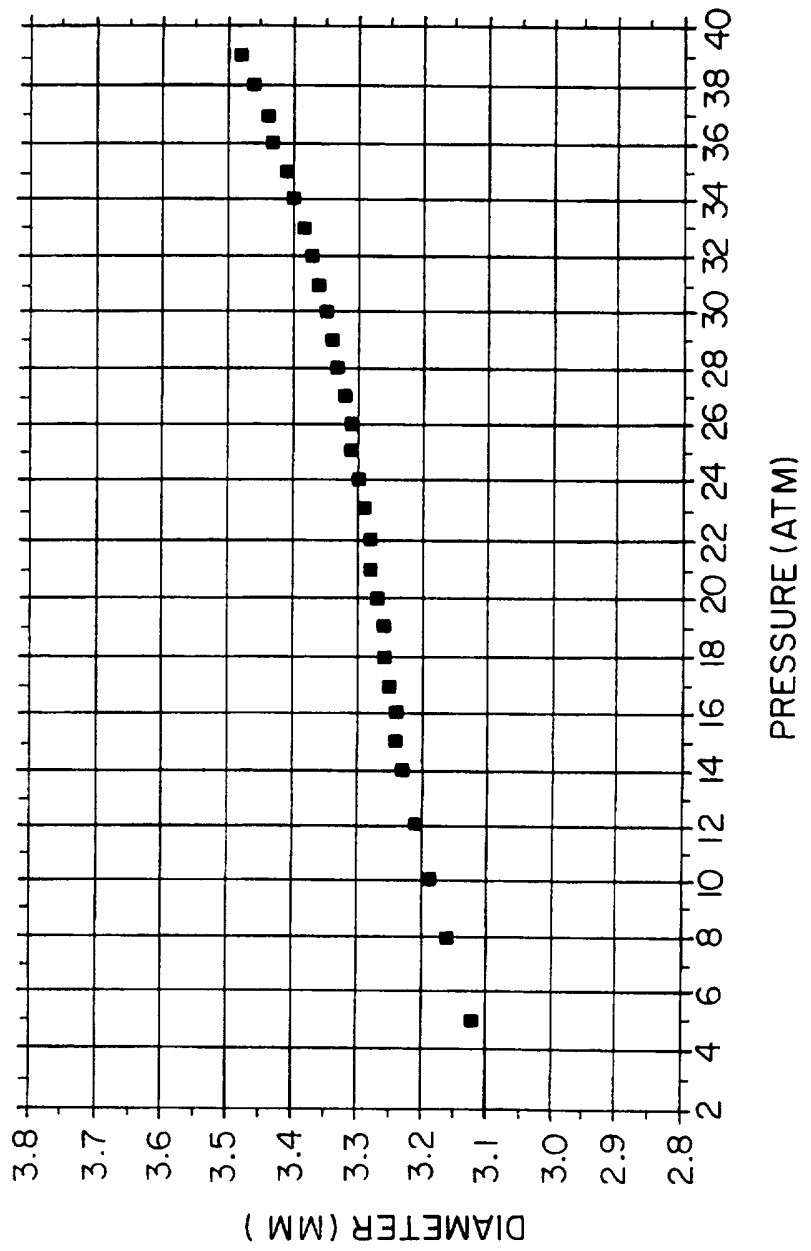
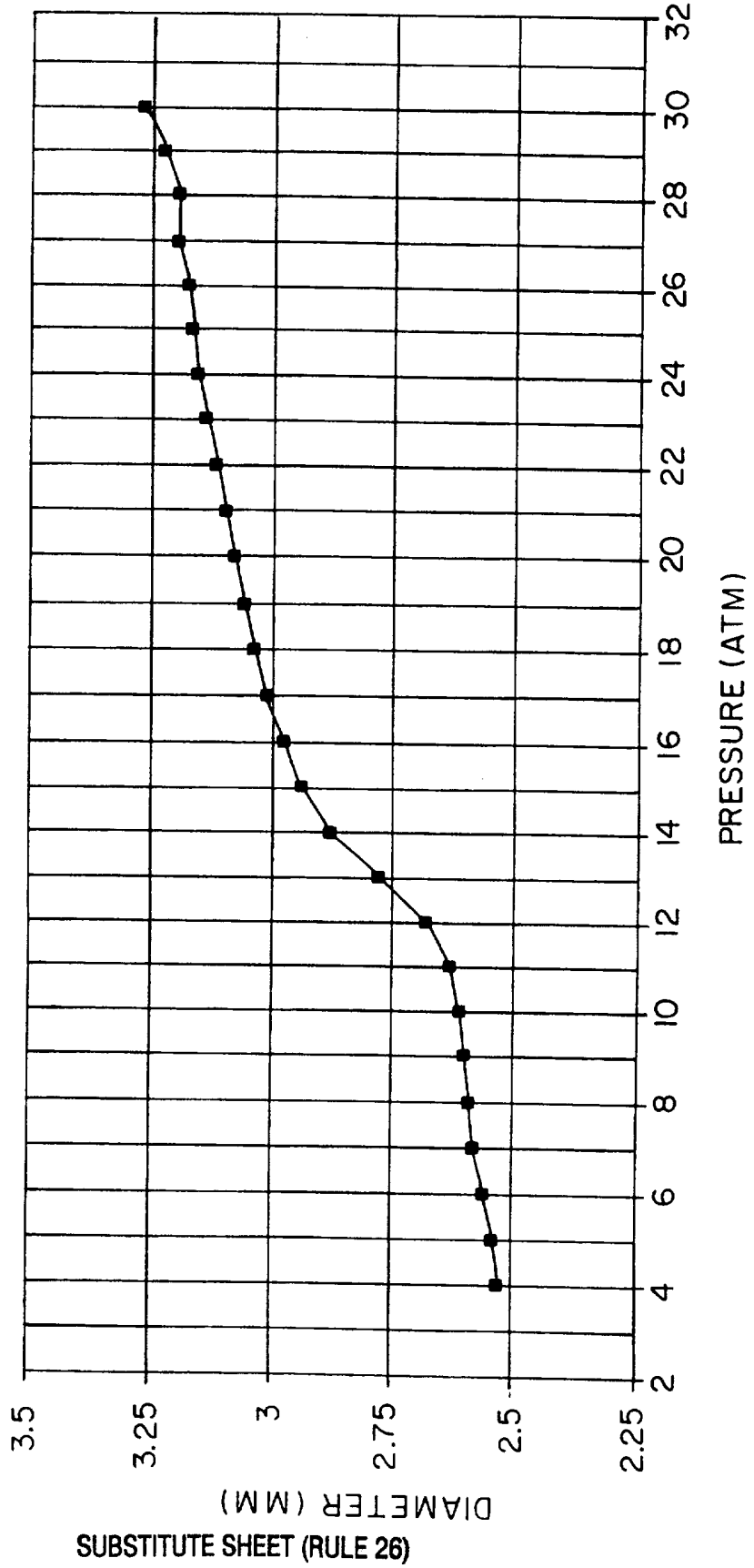

Fig. 7



SUBSTITUTE SHEET (RULE 26)



# INTERNATIONAL SEARCH REPORT

International Application No  
PCT/US 97/04061

A. CLASSIFICATION OF SUBJECT MATTER  
IPC 6 A61M25/00 B29C55/22 B32B1/08

According to International Patent Classification (IPC) or to both national classification and IPC

**B. FIELDS SEARCHED**

Minimum documentation searched (classification system followed by classification symbols)  
IPC 6 A61M B29C B29B B32B

Documentation searched other than minimum documentation to the extent that such documents are included in the fields searched

Electronic data base consulted during the international search (name of data base and, where practical, search terms used)

**C. DOCUMENTS CONSIDERED TO BE RELEVANT**

Category *	Citation of document, with indication, where appropriate, of the relevant passages	Relevant to claim No.
X	WO 96 04951 A (SCHNEIDER) 22 February 1996 see the whole document ---	1-5,7-32
X	EP 0 457 456 A (C.R. BARD INC) 21 November 1991 see column 5, line 10 - line 46; figures ---	32
X	US 5 290 306 A (TROTТА ET AL) 1 March 1994 see column 2, line 1 - column 3, line 29; figure ---	16-31
X	US 4 963 412 A (TAKATA CORP) 16 October 1990 see column 3, line 4 - line 27 ---	16-21, 24-31
P,X	EP 0 745 395 A (ETHICON INC) 4 December 1996 see column 10, line 1 - line 18 -----	16-31

Further documents are listed in the continuation of box C.

Patent family members are listed in annex.

\* Special categories of cited documents :

- \*A\* document defining the general state of the art which is not considered to be of particular relevance
- \*E\* earlier document but published on or after the international filing date
- \*L\* document which may throw doubts on priority claim(s) or which is cited to establish the publication date of another citation or other special reason (as specified)
- \*O\* document referring to an oral disclosure, use, exhibition or other means
- \*P\* document published prior to the international filing date but later than the priority date claimed

- \*T\* later document published after the international filing date or priority date and not in conflict with the application but cited to understand the principle or theory underlying the invention
- \*X\* document of particular relevance; the claimed invention cannot be considered novel or cannot be considered to involve an inventive step when the document is taken alone
- \*Y\* document of particular relevance; the claimed invention cannot be considered to involve an inventive step when the document is combined with one or more other such documents, such combination being obvious to a person skilled in the art.
- \*&\* document member of the same patent family

Date of the actual completion of the international search

23 June 1997

Date of mailing of the international search report

09.07.1997

Name and mailing address of the ISA

European Patent Office, P.B. 5818 Patentlaan 2  
NL - 2280 HV Rijswijk  
Tel. (+ 31-70) 340-2040, Tx. 31 651 epo nl,  
Fax (+ 31-70) 340-3016

Authorized officer

Clarkson, P

# INTERNATIONAL SEARCH REPORT

Information on patent family members

International Application No  
PCT/US 97/04061

Patent document cited in search report	Publication date	Patent family member(s)	Publication date
WO 9604951 A	22-02-96	US 5587125 A	24-12-96
		AU 2935395 A	07-03-96
		CA 2196312 A	22-02-96
		EP 0776226 A	04-06-97
-----			
EP 457456 A	21-11-91	AU 7524391 A	21-11-91
		DE 69123781 D	06-02-97
		DE 69123781 T	15-05-97
		ES 2096625 T	16-03-97
		JP 4231070 A	19-08-92
		US 5358486 A	25-10-94
-----			
US 5290306 A	01-03-94	US 5613979 A	25-03-97
		US 5478320 A	26-12-95
		US 5620649 A	15-04-97
-----			
US 4963412 A	16-10-90	JP 1317847 A	22-12-89
		DE 3919763 A	28-12-89
		DE 8907391 U	21-09-89
		FR 2632895 A	22-12-89
		GB 2221650 A,B	14-02-90
-----			
EP 745395 A	04-12-96	AU 5246696 A	12-12-96
		CA 2177528 A	01-12-96
-----			