

(19) World Intellectual Property
Organization
International Bureau



(43) International Publication Date
19 February 2004 (19.02.2004)

PCT

(10) International Publication Number
WO 2004/014568 A1

- (51) International Patent Classification⁷: **B05B 11/00**
- (21) International Application Number:
PCT/GB2003/003505
- (22) International Filing Date: 12 August 2003 (12.08.2003)
- (25) Filing Language: English
- (26) Publication Language: English
- (30) Priority Data:
0218801.9 13 August 2002 (13.08.2002) GB
60/403,476 13 August 2002 (13.08.2002) US
- (71) Applicant (for all designated States except US): **SHIELD MEDICARE LIMITED** [GB/GB]; 5 Hurlands Business Park, Hurlands Close, Farnham, Surrey GU9 9JE (GB).
- (72) Inventor; and
- (75) Inventor/Applicant (for US only): **SALVAGE, John, Richard** [GB/GB]; Canford House, Westfield Lane, Wrecclesham, Farnham, Surrey GU10 4QR (GB).
- (74) Agents: **PEARSON, James, Ginn et al.**; Abel & Imray, 20 Red Lion Street, London WC1R 4PQ (GB).
- (81) Designated States (national): AE, AG, AL, AM, AT, AU, AZ, BA, BB, BG, BR, BY, BZ, CA, CH, CN, CO, CR, CU, CZ, DE, DK, DM, DZ, EC, EE, ES, FI, GB, GD, GE, GH, GM, HR, HU, ID, IL, IN, IS, JP, KE, KG, KP, KR, KZ, LC, LK, LR, LS, LT, LU, LV, MA, MD, MG, MK, MN, MW, MX, MZ, NI, NO, NZ, OM, PG, PH, PL, PT, RO, RU, SC, SD, SE, SG, SK, SL, SY, TJ, TM, TN, TR, TT, TZ, UA, UG, US, UZ, VC, VN, YU, ZA, ZM, ZW.
- (84) Designated States (regional): ARIPO patent (GH, GM, KE, LS, MW, MZ, SD, SL, SZ, TZ, UG, ZM, ZW), Eurasian patent (AM, AZ, BY, KG, KZ, MD, RU, TJ, TM), European patent (AT, BE, BG, CH, CY, CZ, DE, DK, EE, ES, FI, FR, GB, GR, HU, IE, IT, LU, MC, NL, PT, RO, SE, SI, SK, TR), OAPI patent (BF, BJ, CF, CG, CI, CM, GA, GN, GQ, GW, ML, MR, NE, SN, TD, TG).
- Published:**
— with international search report
- For two-letter codes and other abbreviations, refer to the "Guidance Notes on Codes and Abbreviations" appearing at the beginning of each regular issue of the PCT Gazette.

(54) Title: SPRAY DISPENSER ASSEMBLY AND VESSEL THEREFOR

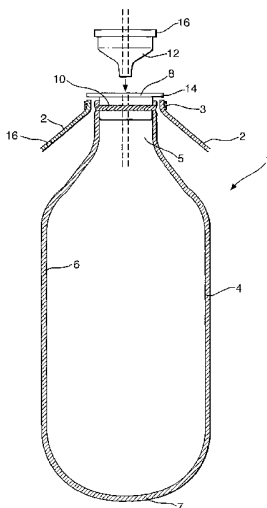

(57) Abstract: A spray dispenser assembly (1) for the dispensing of liquids suitable for use in clean-room environments comprising (a) a collapsible liquid impermeable vessel (4) having an open end comprising a neck portion (5) provided with a collar (8) that is more rigid than the vessel (4); the collar (8) being adapted to sealingly engage with seal means (12) provided between the extraction means of the spray dispenser assembly (1) and the vessel (4); (b) extraction means for extracting liquid from the vessel (4) and dispensing the liquid as a spray; and (c) seal means (12) arranged in sealing position to substantially seal the vessel to the extraction means and substantially inhibit the ingress of air into the vessel (4); the seal means (12) and extraction means being arranged such that the extraction means is operable to dispense liquid from the vessel (4) whilst the seal means (12) is in a sealing position. Collapsible vessels for use in such spray assemblies and kits comprising the collapsible vessels are also disclosed.

WO 2004/014568 A1

Spray Dispenser Assembly and Vessel Therefor

The present invention relates to spray dispenser assemblies and vessels therefor and in particular to those
5 suitable for use in spray dispensing sterile or reactive liquids.

Aerosol or spray dispensers are commonly used for dispensing sprayed sterile or reactive fluids in "clean room" environments such as hospitals, pharmaceutical
10 preparation areas and food preparation areas, and associated support areas (including for example a clean room that provides access to a further clean room having more stringent cleanliness and/or sterility requirements).

Many liquid spray dispensers use an aerosol cartridge
15 to provide compressed gas for atomising the liquid product and driving it out through the nozzle. However, it is now apparent that certain of the gases most often used in spray cartridges, such as fluorocarbons, are highly toxic and harmful to the environment.

20 Spray dispensers fitted with manual trigger sprays are well known. In such a dispenser a liquid spray bottle is fitted with a spray pump which has a spray nozzle at the mouth of a liquid container. When the spray pump is operated, the liquid is drawn up to the spray nozzle
25 through a suction pipe which is inserted within the liquid container and sprayed out through to spray nozzle. For this arrangement to work the spray bottle must be open to the outside atmosphere for the purpose of drawing outside air into the container when the spray pump is operated to
30 spray out the liquid. This mechanism of action is unacceptable for sterile liquids and in a clean room environment as the liquid in the container may be

contaminated by particles, including bacteria, present in the air.

Our previous patent application published as GB 2 333 129 A (herein incorporated in full by reference) describes a spray dispenser with collapsible bag, which attempted to overcome problems in the prior art. These type of dispensers will hereinafter be termed "bag in bottle dispensers". The bag described is in sealing engagement with the trigger pump, and air is prevented from flowing into the bag. The bag collapses as liquid is dispensed. To allow the pump to function correctly a vent is provided from the extraction means, but this is external of the bag to prevent contamination of liquid contained therein.

Continued testing of the dispenser described in GB 2 333 129 A shows that the assembly has a problem with leakage. Studies of the prior art device show that leakage is caused by a poor seal provided between the bag, the bung, the support means and the cap of the support means. Improvements to the bag used overcome this problem.

Accordingly the present invention provides in a first aspect a collapsible liquid impermeable vessel for use in a spray dispenser assembly,

the vessel having an open end comprising a neck portion provided with a collar that is more rigid than the vessel;

the collar being adapted to sealingly engage with seal means provided between the extraction means of the spray dispenser assembly and the vessel.

By providing an at least semi-rigid collar on the vessel, the sealing means may engage directly with the vessel, providing a more complete seal than in the prior art, which relied on a seal between the bung, bag, support neck and cap. This improvement has been shown to provide a

substantially stronger seal and lower the amount of leakage to a negligible level.

The collar may be formed separately from the neck portion and joined thereto around the collar circumference. Preferably the collar is inserted into the neck portion of the vessel and welded around the collar circumference, preferably completely around the collar circumference. A complete circumferential weld may be achieved by performing the welding process more than once, the orientation of the collar and neck in the welding apparatus being altered between each welding process so that a complete and secure circumferential weld is formed. This may be achieved by rotating the neck and collar about the longitudinal axis of the vessel by a suitable angle, for example about 90°, between successive welds being applied.

By providing the collar inside the neck of the vessel, with the seal provided between the inside face of the collar and the seal means, any leakage between the join of the collar to the neck is provided external to the vessel and away from the extraction means. As the vessel is intended for use within a support means, any leakage from the neck to collar join will fall within the support means.

In the prior art device, as the bag was folded over the neck of the support vessel, any leakage from the bag and the seal means could flow onto the exterior of the support means and possibly into contact with the hands of a user. This could be particularly dangerous if the liquid contained within the dispenser was of a hazardous nature.

The vessel may be made from two sheets of plastics material welded together at their edges to form a substantially cylindrical vessel providing a neck end with an open neck portion disposed at one end thereof, with a collar disposed therein, and a closed end opposite the neck

end. It will be understood that the cylindrical vessel will have a cross-sectional shape that is substantially the same along the majority of its length. That cross-sectional shape may be in the form of a very thin
5 rectangular shape when the vessel is empty. When the vessel contains liquid it may lose at least some of its cylindrical shape as the cross-sectional shape of the vessel may vary along its length.

According to a preferred embodiment of the present
10 invention leakage has been shown to be reduced further by trimming the neck portion of the welded vessel before welding the collar in the neck of the vessel. This prevents any excess material on the neck from pinching around the collar, thus potentially forming conduits for
15 liquid to leak through.

The weld between the neck and the collar is preferably
5 mm wide.

In a preferred embodiment the closed end of the vessel, opposite the neck end, is substantially curved.
20 This provides for less stress points on the vessel than if the closed end were flat.

The neck portion may be disposed in the centre of the neck end of the vessel or may be offset to one side of the neck end of the vessel, in which case it is preferred to
25 provide additional strengthening around the neck end of the vessel.

The collar is preferably annular and is adapted to sealingly engage with annular sealing means.
Advantageously the collar is substantially tapered so that
30 pushing seal means into the collar provides a progressively greater seal.

According to a preferred embodiment the collar has an annular lip adapted to rest upon the neck of a support

means. Such collar locates the vessel on the support means and is capable of holding the vessel in position with regard to the support means when the support means is provided with a cap or lid.

5 The vessel preferably comprises flexible sheet or membrane material and generally provides a flaccid bag or pouch which may be incapable of self support. Preferably the vessel comprises a di- or tri- lumen bag.

Depending on the envisaged contents of the vessel the material from which it is made may be very important. It is preferred that the vessel comprises plastics material which is inert, even upon gamma irradiation or contact with biocides or other liquids that it may be used to contain. The material used is preferably elastic so that the vessel
10
15 may be inflated to many times its original size and is preferably resistant to degradation at high temperature.

The collar of the vessel may also comprise plastics material although this is thicker than that used for the vessel itself.

20 The collar and the neck portion (and preferably the rest of the vessel) are preferably made from the same material, which is generally formed from granulated or particulate material which is blow moulded to form the collar and bag. Producing the neck portion (or bag) and
25 collar from the same material has the advantage of ensuring the integrity of the weld as it is easier to weld components of the same material.

The vessel according to the present invention may be provided with seal means in sealing engagement with the
30 collar thereof.

The term "seal means" is intended to encapsulate anything that may provide a seal with the collar. Such a seal includes those that may be formed by virtue of

- 6 -

frictional engagement or by virtue of materials added to form or improve a seal such as adhesives.

The seal means preferably comprises a seal element (such as a stopper, plug or bung) arranged to sealingly engage with the liquid impermeable container proximate the open end thereof so as to seal the collapsible liquid impermeable container. The seal means preferably comprises resiliently flexible material such as rubber or the like.

The seal means may comprise material which is capable of being irradiated and is inert even when in contact with biocides.

The seal means preferably comprises an annular lip which is adapted to sit on an annular lip provided on the collar, providing additional sealing points.

The vessel and seal means arrangement may be in sealing engagement with extraction means for extracting liquid from a vessel and dispensing the liquid as a spray.

As described above most of the improvements in the dispensing device described in GB 2 333 129 relate to the liquid containing vessel.

The present invention, however, also provides in a second aspect a spray dispenser assembly comprising

(a) a collapsible liquid impermeable vessel as described in accordance with the first aspect of the invention;

(b) extraction means for extracting liquid from the vessel and dispensing the liquid as a spray; and

(c) seal means arranged in sealing position to substantially seal the vessel to the extraction means and substantially inhibit the ingress of air into the vessel;

the seal means and extraction means being arranged such that the extraction means is operable to dispense

liquid from the vessel whilst the seal means is in a sealing position.

The seal means is preferably arranged to receive a dispensing line extending into the interior of the vessel.
5 The dispensing line (which may, typically be an elongate tube) preferably extends through the seal means being gripped in sealing engagement with a bore or aperture provided through the seal means. Alternatively, the dispensing line may be bonded in the bore or aperture by a
10 sealing adhesive.

The extraction means preferably comprises pressure means for creating a differential pressure to dispense liquid from the vessel.

The extraction means may comprise pump means
15 (typically actuatable by a trigger pumping mechanism) to dispense liquid from the vessel. The arrangement of the seal means and differential pressure extraction means ensures that any exhaust air or back pressure does not result in ambient air being drawn into the vessel. This may
20 be achieved by ensuring that any vent or back pressure release of the extraction means/pump trigger arrangement is positioned externally of the seal means. Because the vessel collapses as liquid is dispensed, little or no back pressure (vacuum) exists in the vessel.

25 The extraction means preferably further includes a nozzle for ensuring liquid is dispensed as a spray.

The term "extraction means" is intended to include any dispensing mechanism, typically having an inlet disposed in the vessel in fluid communication with an outlet, and
30 typically together with an actuator operable to control the release of the fluid from the vessel. The extraction means may comprise a pump, which may be hand-operated or mechanically assisted (e.g. electrical pump). Such hand-

operated pumps may include push-button and/or trigger actuators. The extraction means may include a valve such as a needle valve, slit valve or poppet valve.

It is preferred that the dispenser further comprises support means for supporting the vessel container.

The support means preferably comprises an outer housing or container for the vessel, which outer housing or container is preferably substantially more rigid than the vessel.

The support means preferably includes an opening or support neck for locating the collar of the vessel. If the vessel has an annular lip this is intended to sit on the support neck of the support means to locate the vessel in the correct position with regard to the support means.

The support means may include an opening or support neck for locating the extraction means. The opening/neck is preferably arranged to cooperate in sealing engagement with the vessel.

The support means may comprise a vent permitting the air inside the support means (but externally) of the vessel to exist at ambient atmospheric pressure.

In one embodiment, the support means may comprise a bottle or the like (such as a plastics bottle), preferably having a neck opening for locating the vessel, and/or the extraction means.

In an alternative embodiment, the support means may comprise a frame structure, preferably having a support neck for locating the vessel, and/or the extraction means.

In a third embodiment the present invention provides a kit comprising a vessel according to the first aspect of the invention and a bung or stopper for sealing engagement therewith. The kit preferably further comprises extraction means for extracting liquid from the vessel and dispensing

the liquid as a spray, sealing means to sealingly engage the vessel and extraction means, and support means for the vessel.

The kit preferably comprises a vessel according to the
5 first aspect of the invention, a conventional pump
dispenser trigger assembly, a bung adapted for sealing
engagement with the vessel and having a bore therein
adapted to sealingly engage with a dip tube of the trigger
assembly, and a support container.

10 It will be appreciated that the vessel may be provided
separate of the support means, trigger assembly and sealing
means, each of which may be adapted from the art. The
invention is intended to encompass the vessel with or
without liquid contained therein.

15 The invention also provides a method of manufacturing
a vessel according to any of the aspects of the invention
described herein. The method may for example include a
step of welding two sheets of plastic material together.
The method may for example include a step of welding
20 together two sheets of plastic material at their edges to
form a substantially cylindrical vessel providing a neck
end with an open neck portion disposed at one end thereof,
with a collar disposed therein, and a closed end opposite
the neck end. The method may include a step of welding a
25 collar to a neck portion of the vessel. The method may
include a step in which excess material is removed from
around the neck portion prior to welding the collar
thereto. The method may include a step of welding the
collar to the neck portion with a welding apparatus, the
30 collar being inserted into the neck portion and the welding
apparatus then welding around the full collar
circumference. Preferably the collar is joined to the neck
portion by performing a plurality of welds, the orientation

of the collar and neck in the welding apparatus being changed between each welding process so that a complete and secure circumferential weld is formed.

The invention will now be further described in a specific embodiment, by way of example only, and with reference to the accompanying drawings in which:

Fig 1 is a schematic sectional view of an exemplary spray dispenser according to the invention;

Fig 2 a, b show details of the vessel according to a preferred embodiment of the invention; and

Fig 3 is a graph showing a comparison between the leakage shown with the system of GB 2 333 129 A and vessels according to the present invention.

Referring to Figure 1, there is shown a spray dispenser 1 comprising an outer plastics bottle 2 (shown in part only) having a neck 3 to which can be fitted a screw threaded plastics cap (not shown). A collapsible liquid impermeable vessel or bag 4 is disposed in the interior of the bottle 2.

The bag 4 comprises flexible plastics material which is inert upon irradiation and contact with biocides. The bag was made by heat welding two or more sheets of such plastics material to make an elongate cylinder with an open neck end 5 and a curved bottom 7. The seam 6 between the layers of material defines the interior of the bag 4.

An annular collar 8 is provided in the neck 5. Material around the seam 6 at neck 5 is cut away so that the collar 8 may be welded in the neck 5 without pinching of excess material. The weld 10 is provided completely around the circumference of the collar 8 and is at least 5 mm in width. Further detail of the collar and neck weld are apparent from Fig. 2.

The neck 5 was welded to the collar 8 by insertion of a conical former into the collar 8 and the application of two heated substantially hemi-annular welding heads (not shown) around the neck and collar as will now be explained in further detail. The two welding heads are brought together around the neck 5 and collar 8 and thus form a substantially annular weld around the whole circumference of the collar 8. The welding heads are then released and the neck 5 and collar 8 are rotated about the longitudinal axis of the vessel by a suitable angle, typically 90 degrees, before performing a further welding process on the collar 8 and neck 5 with the two welding heads. Any unwelded or poorly welded portions remaining from the first welding process are welded by the second welding process. For example, after only one welding process the weld could be unsatisfactory at the portion of the vessel corresponding to the area where the two welding heads meet during the welding process. As a result of the welding process, the weld so formed defines a recessed annular groove.

An annular rubber sealing bung 12 is a tight press fit in the collar 8. Preferably the collar 8 has an annular lip 14 on its upper side, as does the bung 12 (indicated by numeral 16). When the bung 12 is in sealing engagement with the collar 8 the lips 14 and 16 meet to provide an additional sealing surface.

Bung 12 is provided with an axial aperture permitting a dip tube (indicated in dashed lines), connecting to a trigger assembly (not shown) to pass into the interior of the collapsible bag 4. The resilient nature of the bung 12 ensures that an airtight seal is provided between the axial aperture of bung 12 and the dip tube.

- 12 -

Alternatively, or additionally, the dip tube may be thermally bonded to the axial aperture of bung 12, and/or a sealant material applied.

The trigger assembly used in the dispenser device conforms in general to known prior art differential pressure pump arrangements in which actuation of the trigger causes a pressure differential drawing liquid along the dip tube and dispensing as a fine spray. The arrangement of the bung 12 and differential pressure extraction pump trigger arrangement ensures that any exhaust air or back pressure does not result in ambient air being drawn into the collapsible container. This is achieved by ensuring that any vent or back pressure release of the pump trigger arrangement is positioned externally of the seal means. Because the collapsible bag 4 collapses as liquid is dispensed, little or no back pressure (vacuum) exists in the flexible collapsing bag 4.

The plastics bottle 2 is provided with a vent 16 to atmosphere which prevents a partial vacuum being created between the interior walls of bottle 2 and the bag 4 as the bag collapses. Alternatively, the differential pressure created by the pump trigger arrangement may be sufficient to overcome any partial vacuum created in the interior of the bottle 2, externally of the collapsing bag 4.

Because of the extraction and seal arrangement, the spray dispenser of the present invention enables a manually actuatable differential pressure extraction arrangement (such as a trigger pump dispenser) to be used for applications requiring avoidance of atmospheric contamination of the sprayed dispenser contents.

Example

The vessel according to the present invention provides an improved spray dispenser assembly over that described in

GB 2 333 129 A. To prove that the vessel of the present invention has less leakage than its predecessor, the following experiment was carried out.

The following dispenser assemblies were simultaneously
5 tested by filling the vessels with liquid, turning each support bottle upside down and leaving for 12 hours at room temperature and pressure. Leakage from the bags was measured by determining if any fluid was lost from the bag and also studying the bag and bottles for the presence of
10 liquid.

Dispenser 1 - as described in GB 2 333 129 A

Dispenser 2 - collar arrangement as described in accordance with the present invention, with a single weld between the neck and collar and without the removal of
15 material from around the seam at the neck prior to welding

Dispenser 3 - collar arrangement as described in accordance with the present invention, with a 5 mm weld between the neck and collar around the full collar circumference and with the removal of material from around
20 the seam at the neck prior to welding to prevent pinching.

The results are shown in Fig. 3 which shows a considerable reduction in leakage in dispenser 2, to an almost negligible level. No leakage was observed from dispenser 3.

Claims:

1. A spray dispenser assembly for the dispensing of liquids suitable for use in clean-room environments
5 comprising
 (a) a collapsible liquid impermeable vessel having an open end comprising a neck portion provided with a collar that is more rigid than the vessel;
 (b) extraction means for extracting liquid from the
10 vessel and dispensing the liquid as a spray; and
 (c) seal means arranged in sealing position between the extraction means and the vessel, the seal means being so arranged that the collar of the vessel sealingly engages with the seal means, the vessel is substantially sealed to
15 the extraction means, and the ingress of air into the vessel is substantially inhibited;
 the seal means and extraction means being arranged such that the extraction means is operable to dispense liquid from the vessel whilst the seal means is in a
20 sealing position.
2. A spray dispenser assembly according to claim 1, wherein the vessel is at least partially filled with a liquid suitable for use in a cleanroom environment.
3. A spray dispenser assembly according to claim 1 or
25 claim 2, wherein the vessel is at least partially filled with a liquid chosen from one or more of a sterile liquid, a reactive liquid, a sterile alcohol and a biocide.
4. A spray dispenser assembly according to any preceding claim, in which the collar has been formed separately from
30 the neck portion and joined thereto around the collar circumference.

5. A spray dispenser assembly according to any preceding claim, in which the collar has been inserted into the neck portion and welded around the full collar circumference.
6. A spray dispenser assembly according to claim 5, wherein the welding of the collar has been performed a plurality of times by a welding apparatus, the orientation of the collar and neck portion in the welding apparatus being changed between each welding process so that a complete and secure circumferential weld is formed.
7. A spray dispenser assembly according to any preceding claim, in which the vessel comprises two sheets of plastics material welded together at their edges to form a substantially cylindrical vessel providing a neck end with an open neck portion disposed at one end thereof, with a collar disposed therein, and a closed end opposite the neck end.
8. A spray dispenser assembly according to any one of claims 5 to 7, in which excess material is removed from around the neck portion prior to welding the collar thereto.
9. A spray dispenser assembly according to any preceding claim, in which the closed end opposite the neck end is substantially curved.
10. A spray dispenser assembly according to any preceding claim, in which the vessel comprises plastics material which is inert, even upon irradiation or contact with biocides or other liquids that it may be used to contain.
11. A spray dispenser assembly according to any preceding claim, in which the collar and neck portion are made from the same material.
12. A spray dispenser assembly according to any preceding claim, in which the extraction means includes a dispensing line extending through the seal means and inside the

vessel, the dispensing line being gripped in sealing engagement with a bore or aperture provided through the seal means.

13. A spray dispenser assembly according to any preceding claim, in which the vessel collapses from an expanded state to an increasingly collapsed state as liquid is extracted from the vessel.

14. A spray dispenser assembly according to any preceding claim further comprising support means for supporting the vessel.

15. A spray dispenser assembly according to claim 14, in which the support means includes an opening or support neck for locating the extraction means, and the opening/neck is configured to cooperate in sealing engagement with the vessel.

16. A spray dispenser assembly according to claim 15, in which the collar has an annular lip which rests upon the opening or support neck of the support means.

17. A spray dispenser assembly according to any one of claims 14 to 16, in which the support means comprises a vent permitting air inside the support means, but externally of the vessel, to exist at ambient atmospheric pressure.

18. A collapsible liquid impermeable vessel for use in a spray dispenser assembly in accordance with any preceding claim,

the vessel having an open end comprising a neck portion provided with a collar that is more rigid than the vessel;

the collar being adapted to sealingly engage with the seal means provided between the extraction means of the spray dispenser assembly and the vessel.

19. A kit comprising a vessel according to claim 18 and seal means for sealing engagement therewith.

20. A kit according to claim 19 comprising extraction means for extracting liquid from the vessel and dispensing
5 the liquid as a spray, and support means for the vessel, wherein the seal means is able to sealingly engage the vessel and extraction means.

21. A kit according to claim 19 or claim 20, wherein the extraction means is in the form of a conventional pump
10 dispenser trigger assembly, the sealing means is in the form of a bung adapted for sealing engagement with the vessel and having a bore therein adapted to sealingly engage with a dip tube of the trigger assembly, and the support means is in the form of a support container.

15 22. A method of manufacturing a vessel according to claim 18, comprising a step of welding two sheets of plastic material together.

23. A method of manufacturing a vessel according to claim 18, comprising a step of welding the collar to the neck
20 portion.

Fig. 1.

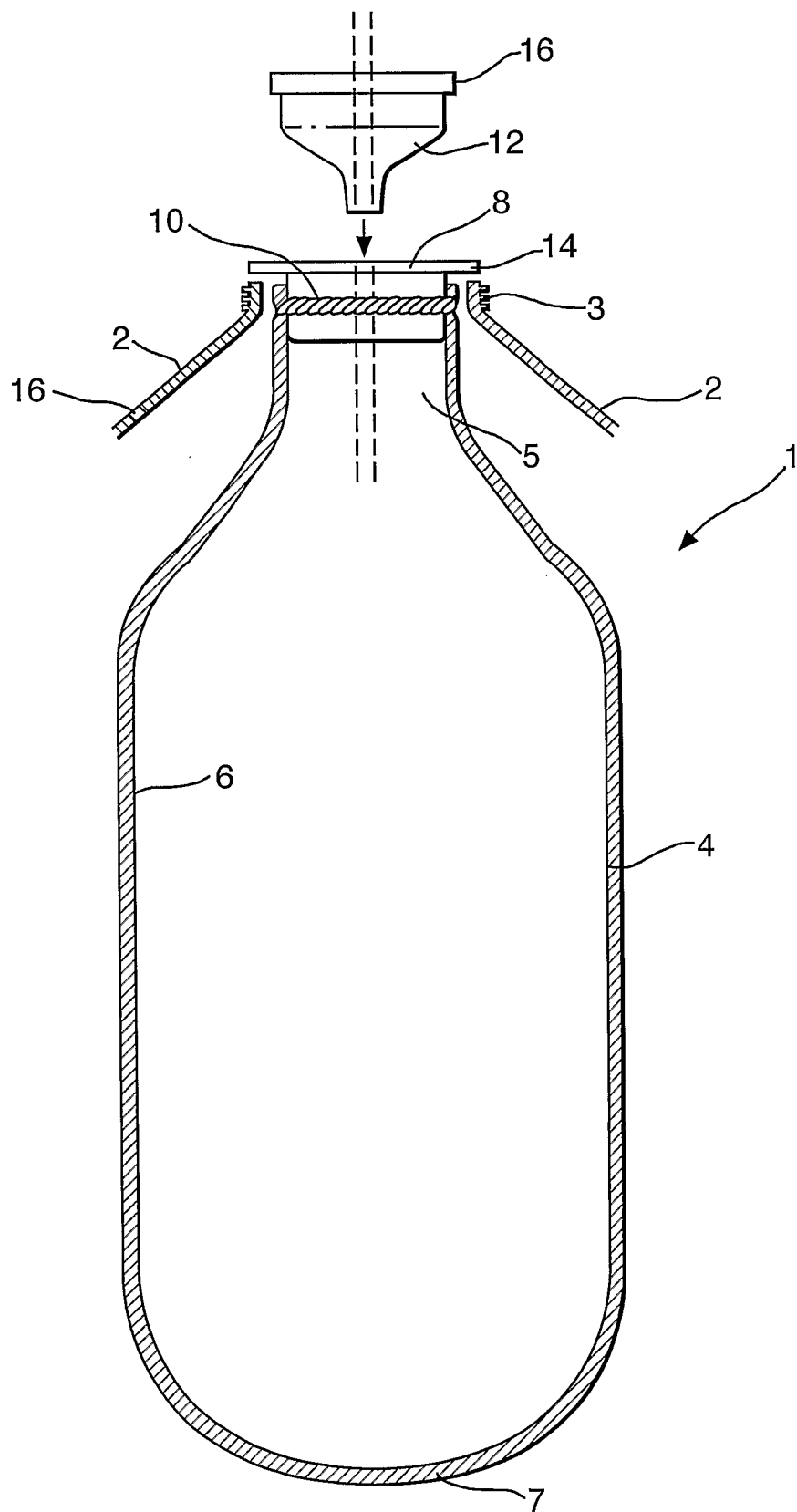

Fig.2(a).

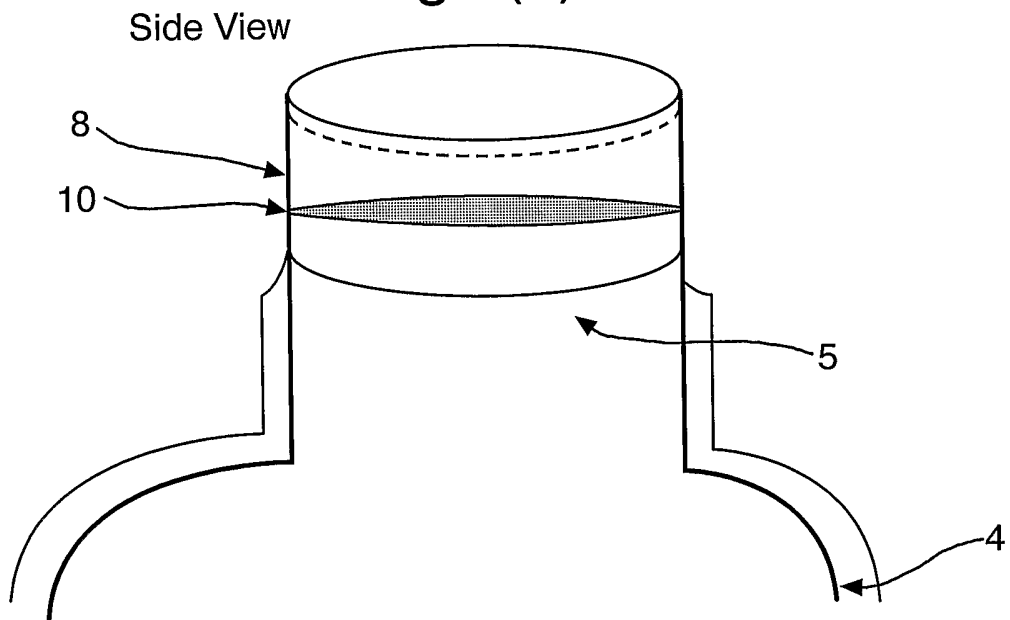

Fig.2(b).

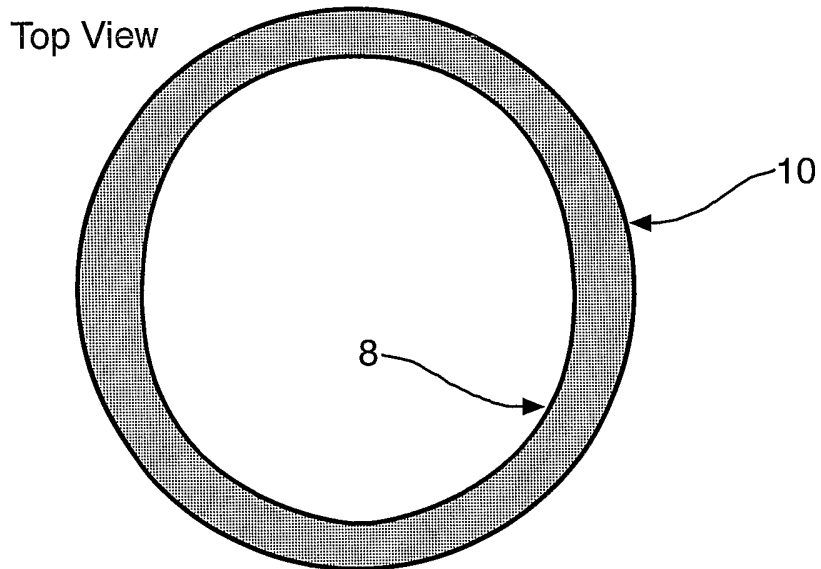
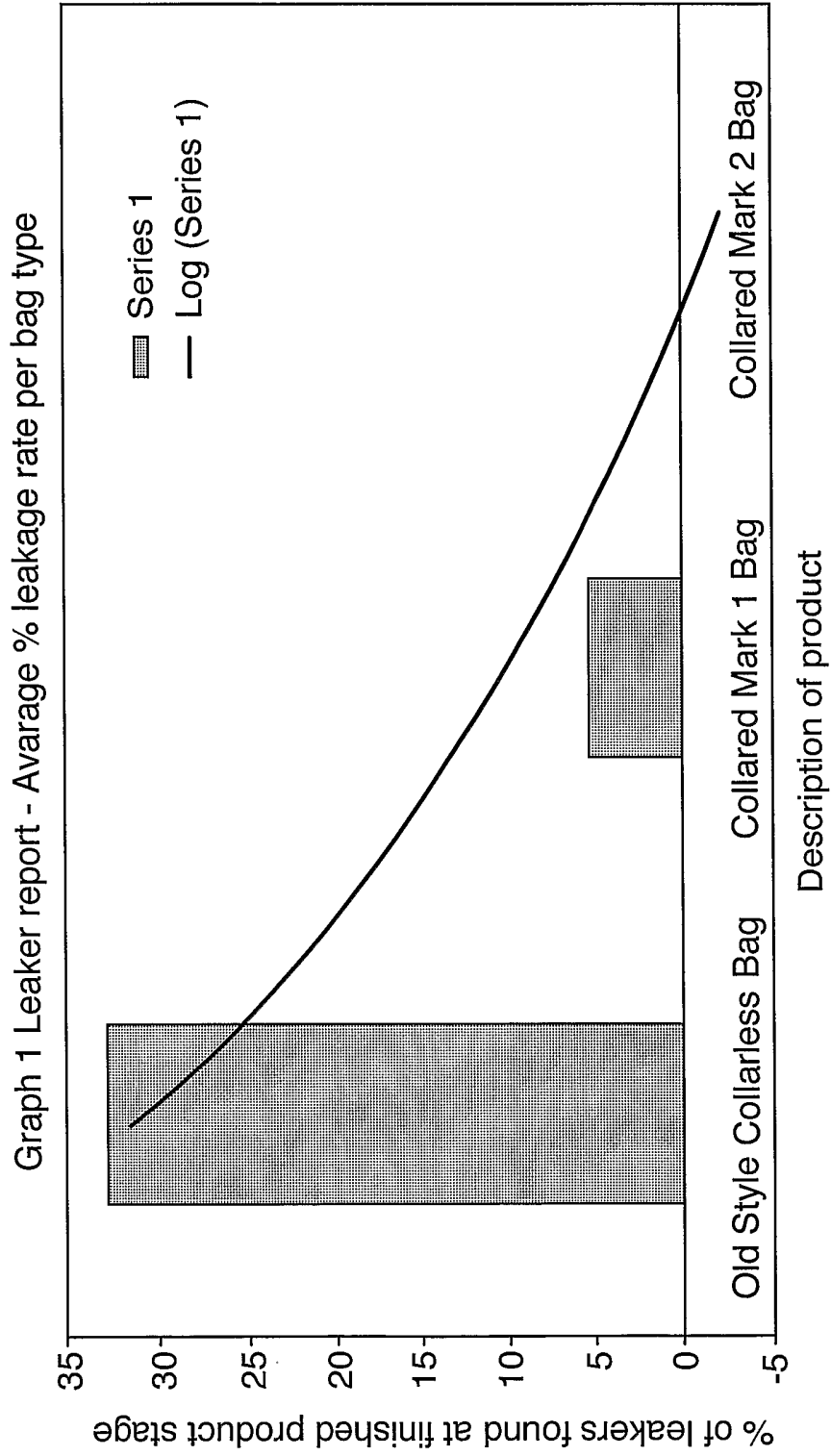

Fig.3.



INTERNATIONAL SEARCH REPORT

Internati	lication No
PCT/GB	03/03505

A. CLASSIFICATION OF SUBJECT MATTER IPC 7 B05B11/00				
According to International Patent Classification (IPC) or to both national classification and IPC				
B. FIELDS SEARCHED				
Minimum documentation searched (classification system followed by classification symbols) IPC 7 B05B				
Documentation searched other than minimum documentation to the extent that such documents are included in the fields searched				
Electronic data base consulted during the international search (name of data base and, where practical, search terms used) EPO-Internal				
C. DOCUMENTS CONSIDERED TO BE RELEVANT				
Category *	Citation of document, with indication, where appropriate, of the relevant passages	Relevant to claim No.		
X	US 5 388 727 A (JOUILLAT CLAUDE) 14 February 1995 (1995-02-14) column 3, line 15 - line 26 column 3, line 50 - line 60 column 4, line 3 - line 6 figures	1-8, 10-20		
X	--- US 5 377 875 A (KOCK RONALD W ET AL) 3 January 1995 (1995-01-03) column 2, line 15 - line 31 column 5, line 16 - line 24 column 6, line 14 - line 21 column 6, line 53 - column 7, line 13 figures --- -/--	1-21		
<table style="width: 100%; border: none;"> <tr> <td style="width: 50%; border: none;"><input checked="" type="checkbox"/> Further documents are listed in the continuation of box C.</td> <td style="width: 50%; border: none;"><input checked="" type="checkbox"/> Patent family members are listed in annex.</td> </tr> </table>			<input checked="" type="checkbox"/> Further documents are listed in the continuation of box C.	<input checked="" type="checkbox"/> Patent family members are listed in annex.
<input checked="" type="checkbox"/> Further documents are listed in the continuation of box C.	<input checked="" type="checkbox"/> Patent family members are listed in annex.			
* Special categories of cited documents :				
<table style="width: 100%; border: none;"> <tr> <td style="width: 50%; border: none;"> *A* document defining the general state of the art which is not considered to be of particular relevance *E* earlier document but published on or after the international filing date *L* document which may throw doubts on priority claim(s) or which is cited to establish the publication date of another citation or other special reason (as specified) *O* document referring to an oral disclosure, use, exhibition or other means *P* document published prior to the international filing date but later than the priority date claimed </td> <td style="width: 50%; border: none;"> *T* later document published after the international filing date or priority date and not in conflict with the application but cited to understand the principle or theory underlying the invention *X* document of particular relevance; the claimed invention cannot be considered novel or cannot be considered to involve an inventive step when the document is taken alone *Y* document of particular relevance; the claimed invention cannot be considered to involve an inventive step when the document is combined with one or more other such documents, such combination being obvious to a person skilled in the art. *&* document member of the same patent family </td> </tr> </table>			*A* document defining the general state of the art which is not considered to be of particular relevance *E* earlier document but published on or after the international filing date *L* document which may throw doubts on priority claim(s) or which is cited to establish the publication date of another citation or other special reason (as specified) *O* document referring to an oral disclosure, use, exhibition or other means *P* document published prior to the international filing date but later than the priority date claimed	*T* later document published after the international filing date or priority date and not in conflict with the application but cited to understand the principle or theory underlying the invention *X* document of particular relevance; the claimed invention cannot be considered novel or cannot be considered to involve an inventive step when the document is taken alone *Y* document of particular relevance; the claimed invention cannot be considered to involve an inventive step when the document is combined with one or more other such documents, such combination being obvious to a person skilled in the art. *&* document member of the same patent family
A document defining the general state of the art which is not considered to be of particular relevance *E* earlier document but published on or after the international filing date *L* document which may throw doubts on priority claim(s) or which is cited to establish the publication date of another citation or other special reason (as specified) *O* document referring to an oral disclosure, use, exhibition or other means *P* document published prior to the international filing date but later than the priority date claimed	*T* later document published after the international filing date or priority date and not in conflict with the application but cited to understand the principle or theory underlying the invention *X* document of particular relevance; the claimed invention cannot be considered novel or cannot be considered to involve an inventive step when the document is taken alone *Y* document of particular relevance; the claimed invention cannot be considered to involve an inventive step when the document is combined with one or more other such documents, such combination being obvious to a person skilled in the art. *&* document member of the same patent family			
Date of the actual completion of the international search		Date of mailing of the international search report		
12 November 2003		25/11/2003		
Name and mailing address of the ISA		Authorized officer		
European Patent Office, P.B. 5818 Patentlaan 2 NL - 2230 HV Rijswijk Tel. (+31-70) 340-2040, Tx. 31 651 epo nl, Fax: (+31-70) 340-3016		Roldán, J		

INTERNATIONAL SEARCH REPORT

Internati	plication No
PCT/GB 03/03505	

C.(Continuation) DOCUMENTS CONSIDERED TO BE RELEVANT		
Category °	Citation of document, with indication, where appropriate, of the relevant passages	Relevant to claim No.
X	US 5 813 571 A (GAUCHER DENIS) 29 September 1998 (1998-09-29) column 6, line 59 - line 64 figures ---	1-8, 10-20
X	FR 2 813 283 A (VALOIS SA) 1 March 2002 (2002-03-01) page 5, line 7 - line 11 figures ---	18,22,23
X	US 5 123 560 A (BODEGA SERGIO ET AL) 23 June 1992 (1992-06-23) column 5, line 2 - line 38 figure 7 ---	18,22,23
A	US 5 662 271 A (DUNNE STEPHEN TERENCE ET AL) 2 September 1997 (1997-09-02) column 15, line 45 - line 62 ---	2,3,10
A	US 5 964 377 A (CORBA ROBERT E ET AL) 12 October 1999 (1999-10-12) column 4, line 43 - line 53 -----	2,3

INTERNATIONAL SEARCH REPORT

Information on patent family members

Internati	Application No
PCT/GB	03/03505

Patent document cited in search report	A	Publication date	Patent family member(s)	Publication date
US 5388727	A	14-02-1995	FR 2694510 A1	11-02-1994
			DE 69311019 D1	03-07-1997
			DE 69311019 T2	08-01-1998
			EP 0582517 A2	09-02-1994
			ES 2105163 T3	16-10-1997
US 5377875	A	03-01-1995	US 5305921 A	26-04-1994
			AU 3245993 A	19-07-1993
			CA 2124679 A1	24-06-1993
			EP 0616591 A1	28-09-1994
			JP 7502239 T	09-03-1995
			WO 9312013 A1	24-06-1993
			US 5813571	A
DE 69605267 D1	30-12-1999			
DE 69605267 T2	13-07-2000			
EP 0769328 A1	23-04-1997			
ES 2141453 T3	16-03-2000			
FR 2813283	A	01-03-2002	FR 2813283 A1	01-03-2002
			BR 0113387 A	29-07-2003
			CN 1449309 T	15-10-2003
			EP 1313568 A1	28-05-2003
			WO 0216047 A1	28-02-2002
US 5123560	A	23-06-1992	AT 100409 T	15-02-1994
			DE 59004263 D1	03-03-1994
			EP 0381627 A1	08-08-1990
			ES 2049012 T3	01-04-1994
US 5662271	A	02-09-1997	AT 160947 T	15-12-1997
			AT 189413 T	15-02-2000
			AU 650870 B2	07-07-1994
			AU 7548491 A	21-10-1991
			BR 9106249 A	09-11-1993
			CA 2078683 A1	22-09-1991
			CA 2206753 A1	22-09-1991
			CN 1061362 A ,B	27-05-1992
			CN 1199009 A ,B	18-11-1998
			CZ 283820 B6	17-06-1998
			DE 69128419 D1	22-01-1998
			DE 69128419 T2	16-04-1998
			DE 69131966 D1	09-03-2000
			DE 69131966 T2	20-07-2000
			DK 521061 T3	30-03-1998
			DK 627230 T3	26-06-2000
			EP 0521061 A1	07-01-1993
			EP 0627230 A2	07-12-1994
			ES 2109943 T3	01-02-1998
			ES 2141786 T3	01-04-2000
			FI 924216 A	21-09-1992
			WO 9114468 A1	03-10-1991
			GB 2256805 A ,B	23-12-1992
			GR 3026065 T3	29-05-1998
			GR 3033317 T3	29-09-2000
			HK 1005059 A1	18-12-1998
			HR 921357 A1	31-10-1995
HU 66175 A2	28-09-1994			

INTERNATIONAL SEARCH REPORT

Information on patent family members

Internat	Publication No
PCT/GB	03/03505

Patent document cited in search report	Publication date	Patent family member(s)	Publication date
US 5662271 A		IE 910929 A1	25-09-1991
		IL 97619 A	26-05-1995
		IN 177383 A1	11-01-1997
		JP 2630347 B2	16-07-1997
		JP 5509241 T	22-12-1993
		KR 139652 B1	01-07-1998
		NO 923647 A	09-11-1992
		NZ 237502 A	25-02-1994
		PL 165926 B1	31-03-1995
		PT 97098 A , B	30-04-1993
		SG 45171 A1	16-01-1998
		SI 9110500 A , B	29-02-1996
		SK 280225 B6	08-10-1999
		RU 2104048 C1	10-02-1998
		US 5497944 A	12-03-1996
		ZA 9102057 A	27-05-1992
US 5964377 A	12-10-1999	AT 240160 T	15-05-2003
		AU 735947 B2	19-07-2001
		AU 1079099 A	03-05-1999
		BR 9814078 A	26-09-2000
		CA 2305281 A1	22-04-1999
		CN 1105604 B	16-04-2003
		DE 69814661 D1	18-06-2003
		EP 1033175 A1	06-09-2000
		EP 1023125 A1	02-08-2000
		JP 2001519235 T	23-10-2001
		NZ 503989 A	26-04-2002
		PL 339913 A1	15-01-2001
		RU 2185893 C2	27-07-2002
		WO 9919075 A1	22-04-1999
ZA 9809382 A	20-04-1999		