



US 20080200885A1

(19) **United States**
(12) **Patent Application Publication**
Schwebel

(10) **Pub. No.: US 2008/0200885 A1**
(43) **Pub. Date: Aug. 21, 2008**

(54) **REMEDY FOR DRY EYE SYNDROME**

(76) Inventor: **Mary L. Schwebel**, Minneapolis, MN (US)

Correspondence Address:
PATTERSON, THUENTE, SKAAR & CHRISTENSEN, P.A.
4800 IDS CENTER, 80 SOUTH 8TH STREET
MINNEAPOLIS, MN 55402-2100 (US)

(21) Appl. No.: **12/079,076**

(22) Filed: **Mar. 24, 2008**

Related U.S. Application Data

(63) Continuation of application No. 11/357,237, filed on Feb. 17, 2006, now Pat. No. 7,357,500, which is a continuation of application No. 11/054,111, filed on Feb. 9, 2005, now Pat. No. 7,036,928, which is a con-

tinuation of application No. 10/855,680, filed on May 27, 2004, now Pat. No. 6,874,884, which is a continuation of application No. 10/645,718, filed on Aug. 21, 2003, now Pat. No. 6,886,933, which is a continuation of application No. 10/123,604, filed on Apr. 15, 2002, now Pat. No. 6,641,264.

Publication Classification

(51) **Int. Cl.**
A61M 35/00 (2006.01)
(52) **U.S. Cl.** **604/300; 604/295; 604/294**

(57) **ABSTRACT**

A treatment for dry eye syndrome. An at least partially sealed chamber including a reservoir for moisture for surrounding the eyes is disclosed. The invention may be transparent for use during the day or in association with prescription or non-prescription lenses. The moisture chamber may also be opaque to act as a blackout mask for sleeping.

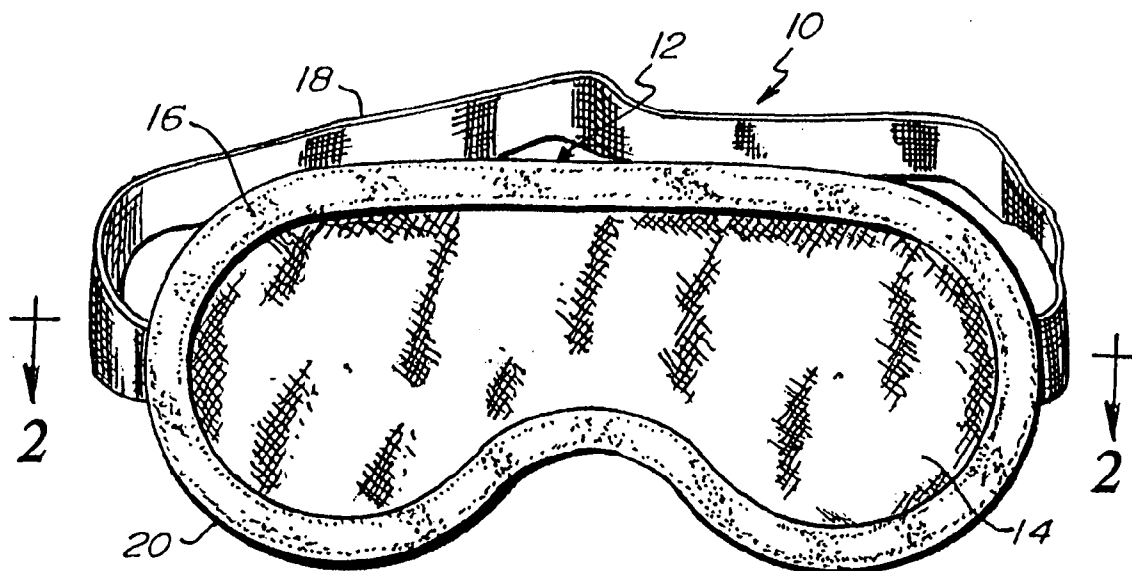

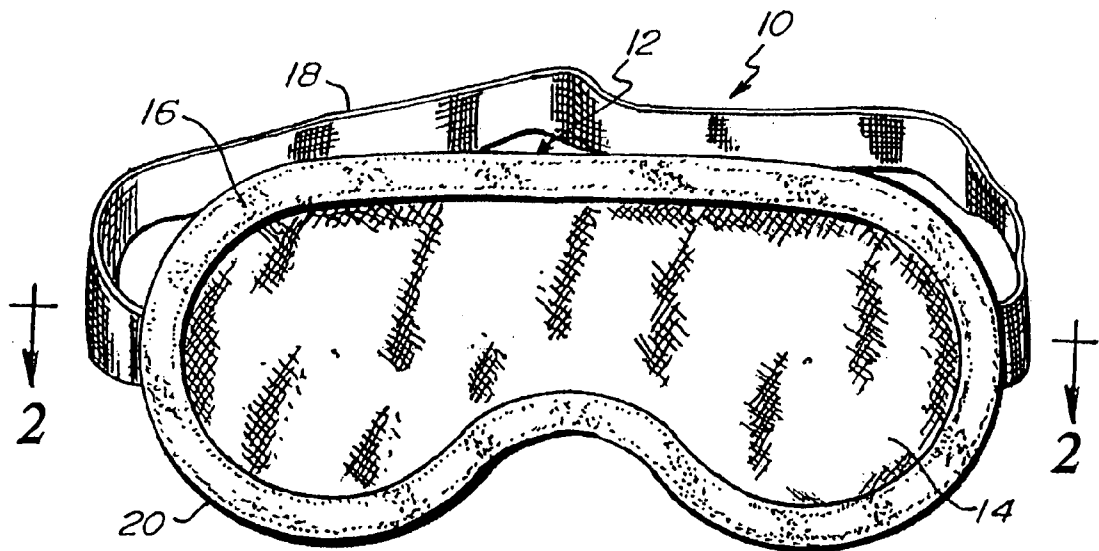

Fig. 1.

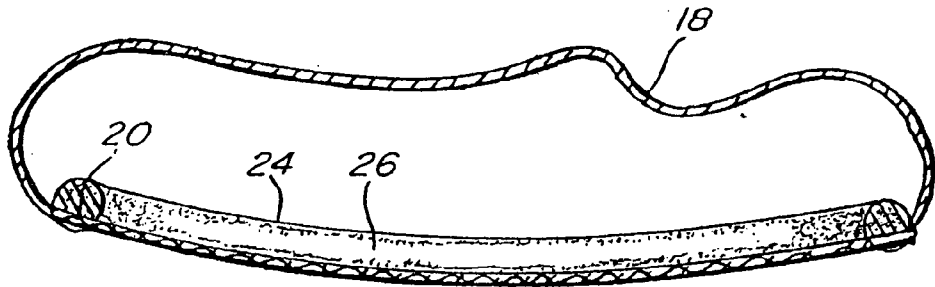

Fig. 2.

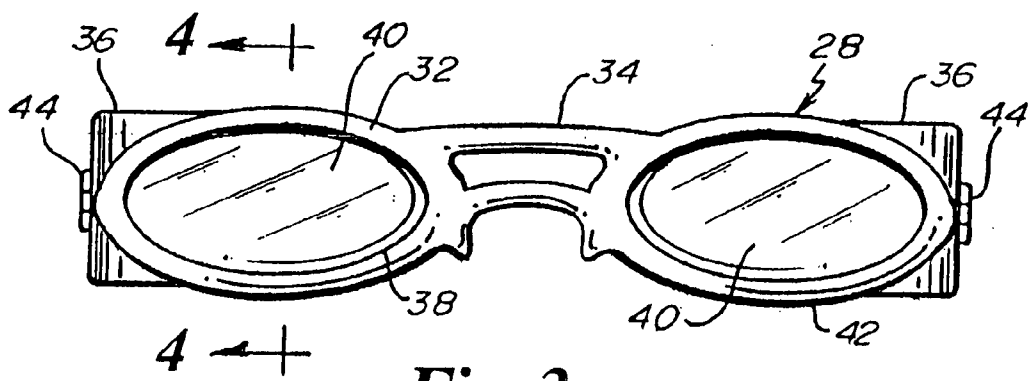

Fig. 3.

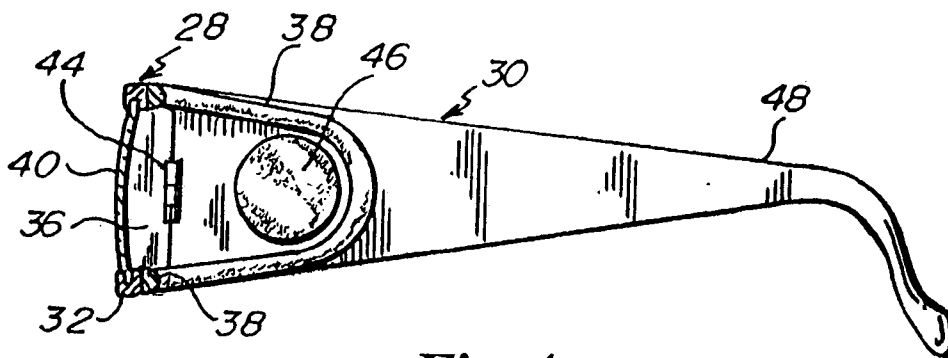

Fig. 4.

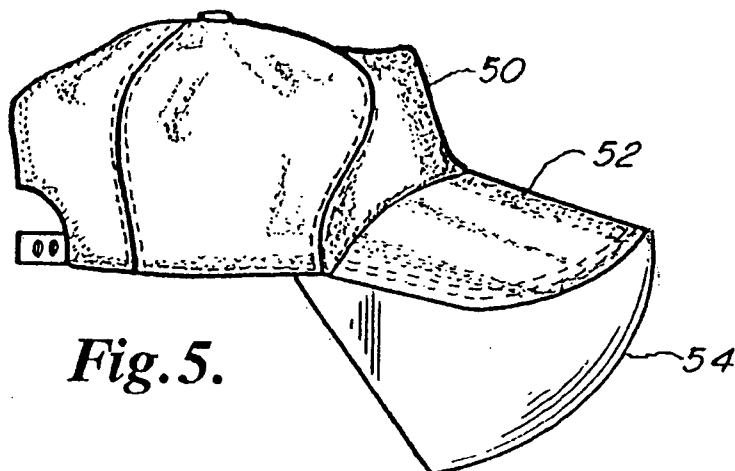

Fig. 5.

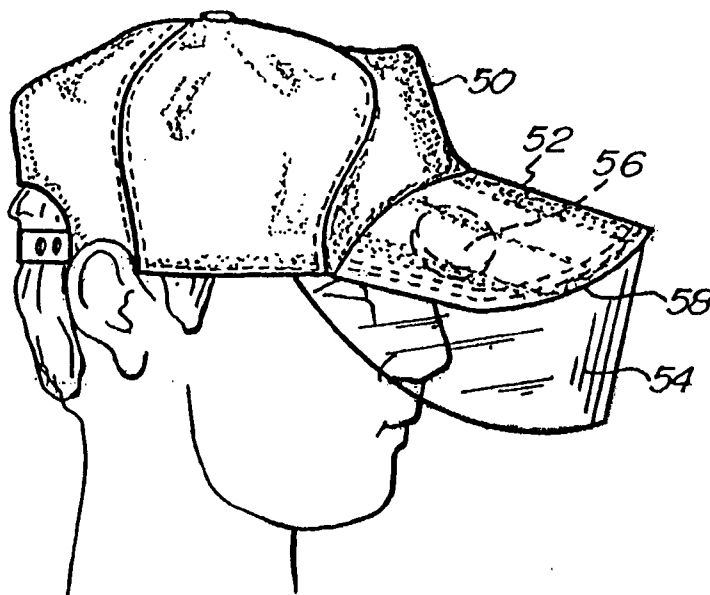

Fig. 6.

REMEDY FOR DRY EYE SYNDROME

RELATED APPLICATION

[0001] This application is continuation of U.S. patent application Ser. No. 11/357,237 filed Feb. 17, 2006 entitled "Remedy For Dry Eye Syndrome" which is a continuation of U.S. patent application Ser. No. 11/054,111 filed Feb. 9, 2005 entitled "Remedy For Dry Eye Syndrome" which is a continuation of U.S. patent application Ser. No. 10/855,680 filed May 27, 2004 entitled "Remedy For Dry Eye Syndrome" which is a continuation of application Ser. No. 10/645,718 filed Aug. 21, 2003, (now U.S. Pat. No. 6,886,933) entitled "Remedy For Dry Eye Syndrome" which is a continuation of application Ser. No. 10/123,604 (now U.S. Pat. No. 6,641,264 B1) entitled "Remedy For Dry Eye Syndrome" and filed Apr. 15, 2002. All of the above referenced applications are incorporated herein by reference.

FIELD OF THE INVENTION

[0002] The present invention relates to the treatment of dry eye syndrome. More particularly, it relates to altering the local environment to reduce the discomfort of dry eye syndrome.

BACKGROUND OF THE INVENTION

[0003] Dry eye syndrome is one of the most commonly treated eye problems in the United States. Dry eye syndrome is also known as keratitis sicca, keratoconjunctivitis sicca (KCS) xerophthalmia, and lacrimal insufficiency. It is estimated that over ten million Americans and 30 million persons worldwide suffer from dry eye syndrome.

[0004] For a large fraction of dry eye patients, dry eye syndrome creates discomfort or annoyance. For those severely afflicted, dry eye syndrome can be debilitating and, in some circumstances, even sight-threatening. In extremely severe cases, dry eye syndrome can even lead to the loss of an eye.

[0005] Dry eye syndrome typically results from deficiency in the quality or quantity of tears produced by the patient. Precorneal tear film has traditionally been considered to have a three-layered structure. The closest to the cornea lies the mucin, or mucus, layer. The mucin layer provides an interface between the corneal epithelium and the remainder of the tear film. Overlying the mucin layer is the watery aqueous layer, which is the thickest layer of the three. The outermost layer of the precorneal tear film is the lipid layer. The lipid layer is an oily film that reduces evaporation from the aqueous layer beneath it.

[0006] The middle aqueous layer provides moisture to the corneal tissue, carries important nutrients, and serves to remove metabolic waste produced by the cornea. Deficiency in any of the three layers of the precorneal tear film can result in complaints of dry, gritty feeling or burning eyes.

[0007] The mucin that forms the mucin layer, nearest the cornea, is secreted by goblet cells in the conjunctiva. The conjunctiva is the transparent tissue that covers the sclera and the backside of the eyelids. The mucin layer functions to decrease surface tension of the tear film. In addition, the cornea itself is hydrophobic. Without the mucin layer to provide a bridge between the cornea and the aqueous layer, the aqueous layer would bead up and allow dry spot formation on the cornea.

[0008] The aqueous layer is secreted primarily by the glands of Wolfring and Krause located in the eyelid margin. The aqueous layer helps provide an optically smooth, transparent surface to the precorneal tear film. The lipid layer is secreted by the meibomian glands, and the glands of Zeiss and Moll. The glands of Zeiss and Moll are also located at the eyelid margin.

[0009] Blinking is essential to maintenance of the precorneal tear film. During each blink, the eyelid wipes over the surface of the cornea, smoothing the mucin layer and spreading the overlying aqueous and lipid layers to provide a completely wetted surface. In between blinks, the tear film thins due to evaporation of the aqueous layer. If evaporation is excessive, dry spots may form on the surface of the cornea.

[0010] Deficiency, or imperfect quality, of any of the three component layers can lead to dry eye symptoms. Many systemic and external factors can contribute to dry eye syndrome. For example, Sjogren's syndrome is associated with arthritic diseases in combination with dry eye and dry mouth. Deficiency of Vitamin A, use of oral contraceptives and environmental factors can all contribute to dry eye syndrome.

[0011] Recent research into the natural history of dry eye syndrome has shown that the disease progresses through four stages. Each stage is a consequence of the preceding stage. The stages are:

- [0012] 1. Loss of water from the aqueous layer of the tear film leading to an increase in the tear film osmolarity;
- [0013] 2. Loss of conjunctival goblet cells and decreased corneal glycogen;
- [0014] 3. Increased loss of corneal squamous epithelial cells;
- [0015] 4. Destabilization of the interface between the corneal surface and the tear film.

[0016] Either decreased secretion of tear film components or increased evaporation lead to increased tear film osmolarity and the following stages that lead to eventual corneal decompensation and the serious consequences of dry eye syndrome.

[0017] The adnexa of the eye may also be involved in dry eye syndrome. The adnexa of the eye include the structures surrounding the eye such as the eyelids, eye lashes, the tear drainage and tear production structures. Blepharitis commonly contributes to dry eye syndrome. Blepharitis typically results from bacterial infection of the tiny glands in the margin of the eyelid. These glands include the glands of Zeiss, Moll and Wolfring as well as the meibomian glands. Most commonly, the affected glands are the meibomian glands. In bacterial blepharitis, bacterial infection causes the meibomian glands to become plugged, and thus not be able to produce a normal lipid layer to contribute to the tear film. Some bacteria that infect the glands also secrete exotoxins that seep out of the glands into the eye and injure the corneal epithelium.

[0018] Treatments of dry eye syndrome vary depending upon the type of presentation. The most common treatment for dry eye syndrome is the use of artificial tear supplements to provide additional moisture and lubrication to the corneal surface. Artificial tear eye drops are placed on the eye by the patient. Artificial tear supplements must be used regularly and often to be effective.

[0019] Lubricant ointments may also be employed. Ointments are usually used at bedtime because they tend to be messy and blur vision. For some patients, even the use of ointments is not sufficient to provide comfort during sleep.

[0020] Tears drain from the eye through the lacrimal drainage system. Tiny openings at the nasal corner of each upper and lower eyelid are called the lacrimal puncta. The lacrimal puncta lead into ducts that drain into the nasopharynx.

[0021] One treatment for dry eye syndrome is to partially or completely close one or more lacrimal puncta to reduce tear outflow into the lacrimal drainage apparatus. Traditionally, this closure was accomplished surgically or by cautery. In the last decade, however, temporary and permanent punctal occlusion plugs have been utilized.

[0022] Permanent punctal plugs are typically made from surgical silicone; temporary plugs are generally made of soluble collagen. Collagen plugs dissolve over a period of days and are helpful in diagnosis.

[0023] Punctal plugs are placed into the lacrimal puncta, or lacrimal drainage ducts. The plugs impede the outflow of tears from the eye. This approach slows the outflow of tears and retains them in the eyes longer, often relieving symptoms. Punctal plugs have the distinct advantage of being readily removable and avoid the issues of scar formation.

[0024] Blepharitis is sometimes treated by the use of antibiotic medications. Another important treatment for blepharitis is the application of warm soaks and lid scrubs. In this form of treatment, the patient applies a warm wet washcloth to the eyelids for a period of time to provide humidity, warmth and to help soften blockage of and restore flow from the meibomian glands. Lid scrubs are practiced by taking a mild, non-irritating soap and vigorously scrubbing the eyelid margins with their eyes closed, so as to massage the meibomian glands and increase production. The surfactant helps to dissolve the greasy blockage of the meibomian glands.

[0025] Patients who have severe dry eye syndrome often suffer disrupted sleep because they cannot go for longer than an hour or so without applying tear supplements to the eyes. This can lead to pronounced sleep deprivation and a consequent reduction in quality of life.

[0026] A variety of researchers have been seeking other medicinal treatments for dry eye syndrome. Largely, this research is directed at pharmaceutical efforts to increase tear production.

[0027] Despite the many treatment options available, there remains no cure for dry eye syndrome. A great many patients still have substantial and even debilitating discomfort because of dry eye syndrome. Very few treatment options exist to provide comfort for dry eye syndrome patients during sleep.

SUMMARY OF THE INVENTION

[0028] The invention generally includes an at least partially enclosed chamber at least partially sealed around the eyes and a reservoir for water or another liquid subject to evaporation to provide a high humidity environment in the vicinity of the eyes. The invention may incorporate a blackout mask for use while sleeping or may incorporate a transparent front structure to accommodate nonprescription or prescription lenses. Another embodiment of the invention may be incorporated into a hat with a brim.

[0029] The invention benefits the patient by increasing comfort and ameliorating the damaging effect of dry eye

syndrome on the patient's eyes. The invention also improves the ability to of the patient to achieve a normal sleep cycle of 6 to 10 hours.

BRIEF DESCRIPTION OF THE DRAWINGS

[0030] FIG. 1 is a rear plan view of a first embodiment of a pre-corneal humidity chamber in accordance with the present invention;

[0031] FIG. 2 is a sectional view of the pre-corneal humidity chamber of FIG. 1;

[0032] FIG. 3 is a rear plan view of a second embodiment of the pre-corneal humidity chamber;

[0033] FIG. 4 is an elevational and sectional view of the pre-corneal humidity chamber of FIG. 3;

[0034] FIG. 5 is an elevational view of a third embodiment of the pre-corneal humidity chamber; and

[0035] FIG. 6 is a perspective view of the pre-corneal humidity chamber depicted in FIG. 5 with a reservoir shown in phantom.

DETAILED DESCRIPTION OF THE INVENTION

[0036] Referring to FIG. 1, a first embodiment of a pre-corneal humidity chamber 10 is depicted. This embodiment generally includes a sleep mask 12, moisture reservoir 14, seal 16 and retaining member 18.

[0037] Sleep mask 12 is preferably made of a moisture impermeable and flexible material. Sleep mask 12 is shaped and sized appropriately to conform to the area surrounding the eyes and orbit in a comfortable fashion. Sleep mask 12 is preferably shaped so that the perimeter 20 thereof fits snugly against the skin of the face.

[0038] Moisture reservoir 14 may include any type of device adapted to contain and release a material subject to evaporation or sublimation. Examples include an absorbent fibrous substance, a chamber for holding a material subject to vaporization and a chemical mixture that releases as a vapor desired substance.

[0039] Seal 16 generally conforms to perimeter 20 of sleep mask 12. Sleep mask 12 may also be configured without seal 16 so long as sleep mask 16 is generally closely fitting to the area surrounding the eyes. Seal 16 is preferably made from a soft, conforming, hypoallergenic material. The cross-section of seal 16 is preferably rounded as depicted in FIG. 2 so as to provide a comfortable junction between seal 16 and the skin of the user. Seal 16 may be made from such materials as closed or open cell foam, silicon or moisture impermeable fabric.

[0040] Retaining member 18 preferably comprises an elastic strap as depicted in FIGS. 1 and 2. Retaining member 18 may however, be constructed of elastic straps, Velcro, temples as used on eyeglasses or any other structure that would appropriately retain sleep mask 12 in a comfortable position in apposition to the face of the user.

[0041] Moisture reservoir 14 is preferably made from an absorbent material, which readily allows for evaporation of water or other evaporative liquids. A sublimating solid may be employed as well. Moisture reservoir 14 may include two layers, an inner layer 24 and a moisture layer 26. Inner layer 24 is preferably a lint free material with antibacterial, antifungal and wicking properties. Moisture layer 26 is preferably made up of an absorbent material. The absorbent material may include super absorbent particles or a jellified water product. Moisture reservoir 14 is preferably removably

attachable to sleep mask 12. Attachment between moisture reservoir 14 and sleep mask 12 may be achieved by pressure sensitive adhesive backing, Velcro or any other attachment mechanism known to the removable attachment arts.

[0042] Moisture reservoir 14 may be provided in the dry state and moistened at the time of desired use. Moisture reservoir 14 may also be provided pre-moistened in a sealed container. Moisture reservoir 14 may be moistened with, for example, purified water, Ringer's solution, or a buffered purified formulation of an appropriate ionic and electrolytic composition to mimic human tears.

[0043] Referring to FIGS. 3 and 4, another embodiment of the invention is depicted. This embodiment of the pre-corneal humidity chamber 10 generally includes a frame front 28 and temples 30. Frame front 28 and temples 30 may be structured in a fashion generally similar to conventional eyeglasses or in a fashion generally similar to a goggle. This description will be most appropriate for an embodiment of the pre-corneal humidity chamber 10 structured similarly to a conventional pair of eyeglasses, however, this should not be considered limiting. One skilled in the art will readily realize that the general principal can be adapted to any sort of eyewear construction.

[0044] Frame front 28 generally includes eye wire 32, bridge 34, end piece 36 and seal 38. Each eye wire 32 encloses and supports lens 40. Lens 40 may be a prescription or non-prescription lens. Lens 40 may also be a colorless transparent lens or a tinted lens. Frame front 28 is constructed to conform generally to the contours of the user's face. Seal 38 preferably runs around the perimeter 42 of frame front 28.

[0045] Seal 38 can be constructed of any soft pliable, moisture impermeable material and serves to seal the juncture between frame front 28 and the face of the user. Referring particularly to FIG. 4, temples 30 generally include hinge 44, moisture reservoir 46, earpiece 48, and a portion of seal 38. Seal 38 preferably continues from frame front 28 to enclose moisture reservoir 46 within the same space that the user's eyes are enclosed in. Temples 30 are mirror images of one another and join frame front 28 at hinge 44. Hinge 44 is made of two halves one connected to end piece 36 and one connected to temple 30. Moisture reservoir 46 is similar in structure to moisture reservoir 14 of the previous embodiment. Moisture reservoir 46 conveniently may be attached to temples 30 but may be incorporated into any part of the pre-corneal humidity chamber 10 that allows evaporation in to the enclosure including the eyes.

[0046] It will be apparent to one skilled in the art that the embodiment depicted in FIGS. 3 and 4 can readily be modified to treat only one eye as can the embodiment depicted in FIGS. 1 and 2.

[0047] Referring to FIGS. 5 and 6, another embodiment of pre-corneal humidity chamber 10 is depicted. This embodiment of the invention generally includes hat 50, brim 52, transparent enclosure 54 and moisture reservoir 56.

[0048] Hat 50 is preferably a baseball style cap but may include any hat or visor having a brim. Brim 52 may be of any shape or size so long as it protrudes forward of the brow on the front of the hat 50.

[0049] Transparent enclosure 54 is preferably an optically clear material. Transparent enclosure 54 extends downward from brim 52 and is configured to fit closely to the face and temples of the user. Transparent enclosure 54 is preferably made from an optically clear transparent material such as polycarbonate or acrylic.

[0050] Moisture reservoir 56 is preferably secured to the under side 58 of brim 52. Moisture reservoir 56 may also be incorporated anywhere within transparent enclosure 54. Moisture reservoir 56 may also be secured to transparent enclosure 54. In addition, moisture reservoir 56 may be an integral part of brim 52 or hat 50.

[0051] Moisture reservoir 56 may be constructed of a fibrous absorbent polymer, which absorbs water. Moisture reservoir 56 may also be made up of super absorbent particles or a jellified water product as indicated in the embodiments above.

[0052] In operation, the pre-corneal humidity chamber 10 is worn by the user so as to enclose the user's eyes. Prior to wearing, the user applies a moisturizing compound such as water, Ringer's solution or an artificial tear solution to moisture reservoir 14, moisture reservoir 46 or moisture reservoir 56. Any of moisture reservoirs 14, 46 or 56 may be supplied in a dry state and moistened at the time of use or may be supplied in a pre-moistened state sealed in a package and applied at the time of desired use.

[0053] Referring to FIGS. 1 and 2, sleep mask 12 is applied over the eyes prior to going to sleep. The evaporation of moisture from moisture reservoir 14 provides a high humidity ambient environment around the eyes, thus, reducing evaporation of the watery portion of the tears, thus enhancing the ability of the patient's tears to provide a comfortable environment for the eyes.

[0054] In addition, sleep mask 12 may be provided with a moisture reservoir 14 capable of holding a large volume of liquid in order to provide a long-term warm moist soak for the eyes. This approach may be used as an adjunct to the treatment of blepharitis. Referring to FIGS. 3 and 4, this embodiment of the pre-corneal humidity chamber 10 is worn in a fashion similar to eyeglasses or conventional goggles. Prior to wearing, moisture reservoir 46 is replaced if pre-moistened or moistened. Moisture reservoir 46 then evaporates moisture to provide a high humidity environment for the eyes within the pre-corneal humidity chamber 10. In addition, the pre-corneal humidity chamber 10 of this embodiment provides protection of evaporation caused by air movement. In addition, pre-corneal humidity chamber 10 of this embodiment tends to exclude atmospheric irritants and other air quality irritants that may irritate the eye.

[0055] Referring to FIGS. 5 and 6, prior to wearing this embodiment of the pre-corneal humidity chamber 10, moisture reservoir 56 is moistened or inserted if pre-moistened. This embodiment of the pre-corneal humidity chamber 10 also tends to protect from increased evaporation due to air movement as well as tending to exclude irritants in the ambient air.

[0056] In testing an exemplary reservoir was placed in a sealed plastic bag. The humidity within the bag rose to in excess of 90% and remained at that level for over eight hours. This is long enough to provide comfort during a normal sleep cycle. A test subject reported dramatically improved comfort during sleep using an embodiment of the invention.

[0057] The present invention may be embodied in other specific forms without departing from the spirit of any of the essential attributes thereof; therefore, the illustrated embodiments should be considered in all respects as illustrative and not restrictive, reference being made to the appended claims rather than to the foregoing description to indicate the scope of the invention.

What is claimed is:

1. A device to improve the comfort and ocular health of a dry eye syndrome subject having a facial structure and to reduce the harmful effect of dry eye syndrome on the eye and adnexa, the device comprising:

a frame front with temples having an exterior surface and an opposing interior surface defined by the frame front and the temples, the interior surface aligning substantially parallel to and conforming to the subject's facial structure;

a resilient conforming member attached to the interior surface of the frame front and at least one temple and extending around a perimeter of a closed geometric figure that follows the interior surface and is situated between the interior surface of the frame front and the facial structure so as to create a microenvironment between the interior surface of the frame front and the facial structure;

an indentation formed in the interior surface of the temples, the indentation situated within the perimeter of the closed geometric figure;

a substantially transparent lens enclosed and supported by the frame front;

an absorbent moisture pad adapted to evaporatively release an absorbed substance, the absorbent moisture pad being removeably insertable in the indentation; and earpieces on both temples, adapted to keep the conforming member snugly abutted against the facial structure so as to maintain the microenvironment.

2. The device as claimed in claim 1, in which the absorbent moisture pad is supplied dry and moistened at the time of desired use.

3. The device as claimed in claim 1, in which the absorbent moisture pad is supplied in a premoistened state in sealed packaging.

4. The device as claimed in claim 1, in which the absorbent moisture pad comprises a first absorbent layer and a second layer having wicking and anti microorganism properties.

5. The device as claimed in claim 1, in which the absorbent moisture pad is moistened with a liquid selected from a group consisting of water, purified water, Ringer's solution and a buffered formulation of appropriate ionic and electrolytic composition to mimic human tears.

6. The device as claimed in claim 1, in which a humidity level achieved within the microenvironment exceeds 90% relative humidity.

7. The device as claimed in claim 1, in which a humidity level achieved within the microenvironment exceeds 90% relative humidity and is maintained in excess of 6 hours.

8. The device as claimed in claim 1, in which the device is substantially sealed to the face of the dry eye syndrome subject.

9. The device as claimed in claim 1, in which the conforming member is situated in such a way as to create the microenvironment surrounding only one of the subject's eyes.

10. A method for ameliorating the effects of dry eye syndrome on eyes, the method comprising:

substantially enclosing the eyes and adnexa in a moisture chamber adapted to fit closely to a face of a dry eye syndrome subject thereby creating a local atmospheric microenvironment in the vicinity surrounding the eye, the moisture chamber comprising a frame front, temples, transparent lenses, and having an exterior surface and an opposing interior surface, the interior surface substantially aligning parallel to and conforming to the subject's facial structure;

interposing a soft, resilient, conforming member between the interior surface of the moisture chamber and the face, the conforming member creating a closed geometric shape extending around a perimeter of the frame front and at least a portion of the temples;

removeably inserting an absorbent moisture pad in an indentation in the temple within the interior of the closed geometric shape, the absorbent moisture pad being in a moistened state; and

maintaining within the local atmospheric microenvironment, an atmosphere rich in a vaporized substance that provides beneficial effect to the eyes.

11. The method as claimed in claim 10, further comprising moistening the moisture pad with a liquid selected from a group consisting of water, purified water, Ringer's solution, and a buffered formulation of an appropriate ionic and electrolytic composition to mimic human tears.

12. The method as claimed in claim 10, further comprising covering the absorbent moisture pad with a layer having wicking and anti microorganism properties.

13. The method as claimed in claim 10, further comprising encapsulating the absorbent moisture pad in an impermeable package in a premoistened state and opening the impermeable package when it is desire to use the absorbent moisture pad.

14. The method as claimed in claim 10, further comprising substantially sealing the chamber to the face with a conforming seal.

15. The method as claimed in claim 10, in which a humidity level achieved within the microenvironment exceeds 90% relative humidity.

16. The method as claimed in claim 10, in which a humidity level achieved within the microenvironment exceeds 90% relative humidity and is maintained for an excess of 6 hours.

* * * * *