



- (51) International Patent Classification:
B23P 6/00 (2006.01) B64F 5/00 (2006.01)
B23P 6/04 (2006.01)
- (21) International Application Number:
PCT/US2015/011576
- (22) International Filing Date:
15 January 2015 (15.01.2015)
- (25) Filing Language: English
- (26) Publication Language: English
- (30) Priority Data:
14/158,077 17 January 2014 (17.01.2014) US
- (71) Applicant: SIKORSKY AIRCRAFT CORPORATION
[US/US]; 6900 Main Street, P.O. Box 9729, Stratford,
Connecticut 06615-9129 (US).
- (72) Inventor: URBAN, Michael R.; 110 Pleasant Drive,
Southbury, Connecticut 06488 (US).

- (74) Agent: LEVY, Howard I.; Cantor Colburn LLP, 20
Church Street, 22nd Floor, Hartford, Connecticut 06103
(US).
- (81) Designated States (unless otherwise indicated, for every
kind of national protection available): AE, AG, AL, AM,
AO, AT, AU, AZ, BA, BB, BG, BH, BN, BR, BW, BY,
BZ, CA, CH, CL, CN, CO, CR, CU, CZ, DE, DK, DM,
DO, DZ, EC, EE, EG, ES, FI, GB, GD, GE, GH, GM, GT,
HN, HR, HU, ID, IL, IN, IR, IS, JP, KE, KG, KN, KP, KR,
KZ, LA, LC, LK, LR, LS, LU, LY, MA, MD, ME, MG,
MK, MN, MW, MX, MY, MZ, NA, NG, NI, NO, NZ, OM,
PA, PE, PG, PH, PL, PT, QA, RO, RS, RU, RW, SA, SC,
SD, SE, SG, SK, SL, SM, ST, SV, SY, TH, TJ, TM, TN,
TR, TT, TZ, UA, UG, US, UZ, VC, VN, ZA, ZM, ZW.
- (84) Designated States (unless otherwise indicated, for every
kind of regional protection available): ARIPO (BW, GH,
GM, KE, LR, LS, MW, MZ, NA, RW, SD, SL, ST, SZ,
TZ, UG, ZM, ZW), Eurasian (AM, AZ, BY, KG, KZ, RU,
TJ, TM), European (AL, AT, BE, BG, CH, CY, CZ, DE,

[Continued on next page]

(54) Title: COMPOSITE BONDED REPAIR METHOD

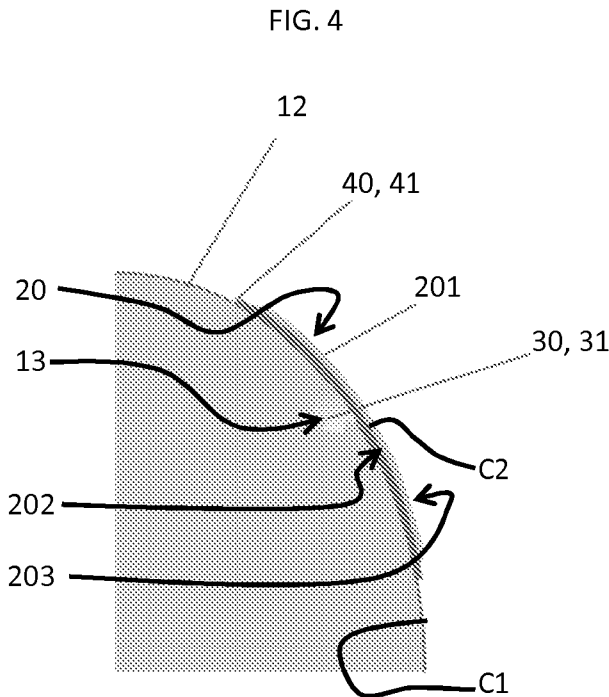

(57) Abstract: A composite bonded repair method for an aircraft is provided. The method includes generating a doubling patch of a portion of the aircraft from topographic data, filling damage at the portion of the aircraft with filler material, applying adhesive to the portion of the aircraft and the filler material and adhering the doubling patch to the adhesive.

WO 2015/109077 A1

DK, EE, ES, FI, FR, GB, GR, HR, HU, IE, IS, IT, LT,
LU, LV, MC, MK, MT, NL, NO, PL, PT, RO, RS, SE,
SI, SK, SM, TR), OAPI (BF, BJ, CF, CG, CI, CM, GA,
GN, GQ, GW, KM, ML, MR, NE, SN, TD, TG).

— *as to the applicant's entitlement to claim the priority of
the earlier application (Rule 4.17(iii))*

Published:

— *with international search report (Art. 21(3))*

Declarations under Rule 4.17:

— *as to applicant's entitlement to apply for and be granted
a patent (Rule 4.17(ii))*

COMPOSITE BONDED REPAIR METHOD

BACKGROUND OF THE INVENTION

[0001] The subject matter disclosed herein relates to a composite bonded repair method and, more particularly, to an advanced integrated composite bonded repair method and an aircraft including a composite bonded repair.

[0002] Composite structures are increasingly prevalent in various aircrafts and naval structures and, as piloted, remote piloted, autonomous aircraft and ship structures evolve, the use of metallic components is waning. This transformation is very evident in certain aircrafts, such as helicopters, in particular, which make extensive use of carbon/epoxy in both rotating and non-rotating structural components. This mix of structural materials offers many benefits to reduce lifetime costs and introduces new requirements for optimized field support.

[0003] The carbon/epoxy mix of structural materials in helicopters and other aircraft incorporates a significant amount of honeycomb stiffened structures in the skins, access panels, doorways, ramps and floors. While the structural materials have been developed to be highly impact damage resistant and tolerant, transport can introduce scenarios of potential damage. Moreover, cramped spaces and confined passageways aboard ships can raise the probability of accidental handling damage. In addition, working on and moving helicopters and other aircraft within a ship that is pitching and rolling can increase the probability of mechanically induced damage.

[0004] The same ship board environments that raise the probability of mechanical damage can also limit the capability of onboard repairs. Limited space onboard ships can restrict maintenance when compared to land based operations.

BRIEF DESCRIPTION OF THE INVENTION

[0005] According to one aspect of the invention, a composite bonded repair method for an aircraft is provided. The method includes generating a doubling patch of a portion of the aircraft from topographic data, filling damage at the portion of the aircraft with filler material, applying adhesive to the portion of the aircraft and the filler material and adhering the doubling patch to the adhesive.

[0006] According to another aspect of the invention, a composite bonded repair method for an aircraft is provided. The method includes generating topographic data of a portion of an outer skin of an aircraft surrounding damage formed in the outer skin, generating a doubling patch of the portion of the outer skin of the aircraft from the

topographic data, filling the damage with a filler material, applying adhesive to the portion of the outer skin of the aircraft and the filler material and adhering the doubling patch to the adhesive.

[0007] According to yet another aspect of the invention, an aircraft is provided and includes an outer skin including fuselage sections and aerodynamic elements, filler material disposed in damage formed in the outer skin, adhesive applied to a portion of the outer skin surrounding the damage and a doubling patch adhered to the adhesive. The doubling patch is formed from topographic data of the portion of the outer skin surrounding the damage.

[0008] These and other advantages and features will become more apparent from the following description taken in conjunction with the drawings.

BRIEF DESCRIPTION OF THE DRAWINGS

[0009] The subject matter, which is regarded as the invention, is particularly pointed out and distinctly claimed in the claims at the conclusion of the specification. The foregoing and other features, and advantages of the invention are apparent from the following detailed description taken in conjunction with the accompanying drawings in which:

[0010] FIG. 1 is a perspective view of an aircraft;

[0011] FIG. 2 is a flow diagram illustrating a composite bonded repair method for use with the aircraft in accordance with embodiments;

[0012] FIG. 3 is a perspective view of a repaired portion of an aircraft in accordance with embodiments; and

[0013] FIG. 4 is a side view of the repaired portion taken along line A-A of FIG. 3.

[0014] The detailed description explains embodiments of the invention, together with advantages and features, by way of example with reference to the drawings.

DETAILED DESCRIPTION OF THE INVENTION

[0015] With reference to FIG. 1, an aircraft 1 is provided and may be a helicopter, an airplane or any other similar device. The aircraft 1 includes an outer skin 2 and the outer skin 2 includes fuselage sections 3 and aerodynamic elements 4. The fuselage sections 3 define an interior of the aircraft in which navigational components are housed and, in the case of manned aircraft, the pilot and passengers sit. The aerodynamic elements 4 include wings and other similar features. In accordance with aspects as will be discussed below, damage to the outer skin 2 may be caused by transport of the aircraft 1, maintenance of the aircraft 1 and or impacts during flight. Such damage may be repaired by filler material being disposed in the

damaged sections such that the damaged sections are filled, adhesive being applied to the outer skin 2 around the damaged sections and a doubling patch being adhered to the adhesive where the doubling patch is formed from topographic data of the outer skin 2.

[0016] With reference to FIGS. 2-4, a composite bonded repair method for an aircraft, such as the aircraft 1 of FIG. 1, is provided. The method includes generating topographic data of a portion 11 of an outer skin 12 of an aircraft where the portion 11 is defined to surround damage 13 formed in the outer skin 12 (operation 100). The generating of the topographic data may include at least one of scanning the portion 11 of the outer skin 12 of the aircraft with a scanning unit 15 (see FIG. 1) coupled to a computing device 16 (see FIG. 1) and deriving data from a model of the aircraft stored in memory units or storage 17 (see FIG. 1) of the computing device 16.

[0017] The method further includes generating a doubling patch 20 of the portion 11 of the outer skin 12 of the aircraft from the topographic data (operation 110). The generating of the doubling patch 20 may be accomplished by three-dimensional (3-D) printing processes executed by a 3-D printing element 21 (see FIG. 1) or by forming on a mold through similar three-dimensional (3-D) printing processes. The doubling patch 20 and/or the mold may be formed of non-metallic material, such as graphite or fiberglass cloth. As shown in FIG. 3, the doubling patch 20 includes body 201 having an inner surface 202 and an outer surface 203, which is opposite the inner surface 202. The inner surface 202, in particular, has a shape that corresponds to a shape of the portion 11 of the outer skin 12 of the aircraft. That is, where the portion 11 of the outer skin 12 has a continuously variable external contour with curvature C1, the inner surface 202 may have a similarly continuously variable external contour with curvature C2. The outer surface 203 can have a similar curvature as the inner surface 202 or a different shape altogether.

[0018] The method further includes filling the damage 13 with a filler material 30 (operation 120), applying adhesive 40 to the portion 11 of the outer skin 12 of the aircraft and the filler material 30 (operation 130) and adhering the doubling patch 20 to the adhesive 40 (operation 140). In accordance with embodiments, the filler material 30 may include graphite epoxy 31 or another similar material and the adhesive 40 may include two-sided tape or film or paste adhesive 41. In accordance with further embodiments, the adhesive 40 may include strain monitoring elements, such as fiber optic strain sensors, while the adhering of the doubling patch 20 to the adhesive 40 may include at least one of vacuum pressurizing the doubling patch 20 toward the portion 11 of the outer skin 12 of the aircraft and applying a three-dimensional printed form block onto the doubling patch 20.

[0019] Repairs completed by the repair method described above can be subject to at least three or more mechanical loading forms including static, ultimate and limit loading. All repairs would be required to restore full quasi-static load carrying capability, they should hold up under cyclic loading for a predetermined period and they should be resistant to high strain rate load induced by impact, ballistics and other rate dependent loadings. While the repair method described above can stand on its own, fastened or hybrid-fastened/bonded connections may be required in certain situations. Thus, when they are needed, fasteners can be provided to maintain the doubling patch 20, the filler material 30 and the adhesive 40 in position at least as long as needed for the adhesive 40 to cure.

[0020] While the invention has been described in detail in connection with only a limited number of embodiments, it should be readily understood that the invention is not limited to such disclosed embodiments. Rather, the invention can be modified to incorporate any number of variations, alterations, substitutions or equivalent arrangements not heretofore described, but which are commensurate with the spirit and scope of the invention. Additionally, while various embodiments of the invention have been described, it is to be understood that aspects of the invention may include only some of the described embodiments. Accordingly, the invention is not to be seen as limited by the foregoing description, but is only limited by the scope of the appended claims.

CLAIMS:

What is claimed is:

1. A composite bonded repair method for an aircraft, the method comprising:
generating a doubling patch of a portion of the aircraft from topographic data;
filling damage at the portion of the aircraft with filler material;
applying adhesive to the portion of the aircraft and the filler material; and
adhering the doubling patch to the adhesive.
2. The method according to claim 1, further comprising generating the topographic data by at least one of scanning the portion of the aircraft and deriving data from a model of the aircraft.
3. The method according to claim 1, wherein the generating of the doubling patch comprises three-dimensional printing.
4. The method according to claim 1, wherein the doubling patch comprises non-metallic material.
5. The method according to claim 1, wherein the filler material comprises graphite epoxy.
6. The method according to claim 1, wherein the adhesive comprises two-sided tape or film or paste adhesive.
7. The method according to claim 1, wherein the adhering of the doubling patch comprises at least one of vacuum pressurizing the doubling patch toward the portion of the aircraft and applying a three-dimensional printed form block onto the doubling patch.
8. A composite bonded repair method for an aircraft, the method comprising:
generating topographic data of a portion of an outer skin of an aircraft surrounding damage formed in the outer skin;
generating a doubling patch of the portion of the outer skin of the aircraft from the topographic data;
filling the damage with a filler material;
applying adhesive to the portion of the outer skin of the aircraft and the filler material;
and
adhering the doubling patch to the adhesive.
9. The method according to claim 8, wherein the generating of the topographic data comprises at least one of scanning the portion of the outer skin of the aircraft and deriving data from a model of the aircraft.

10. The method according to claim 8, wherein the generating of the doubling patch comprises three-dimensional printing.

11. The method according to claim 8, wherein the doubling patch comprises non-metallic material.

12. The method according to claim 8, wherein the filler material comprises graphite epoxy.

13. The method according to claim 8, wherein the adhesive comprises two-sided tape or film or paste adhesive.

14. The method according to claim 8, wherein the adhering of the doubling patch comprises at least one of vacuum pressurizing the doubling patch toward the portion of the outer skin of the aircraft and applying a three-dimensional printed form block onto the doubling patch.

15. An aircraft, comprising:

an outer skin including fuselage sections and aerodynamic elements;

filler material disposed in damage formed in the outer skin;

adhesive applied to a portion of the outer skin surrounding the damage; and

a doubling patch adhered to the adhesive, the doubling patch being formed from topographic data of the portion of the outer skin surrounding the damage.

FIG. 1

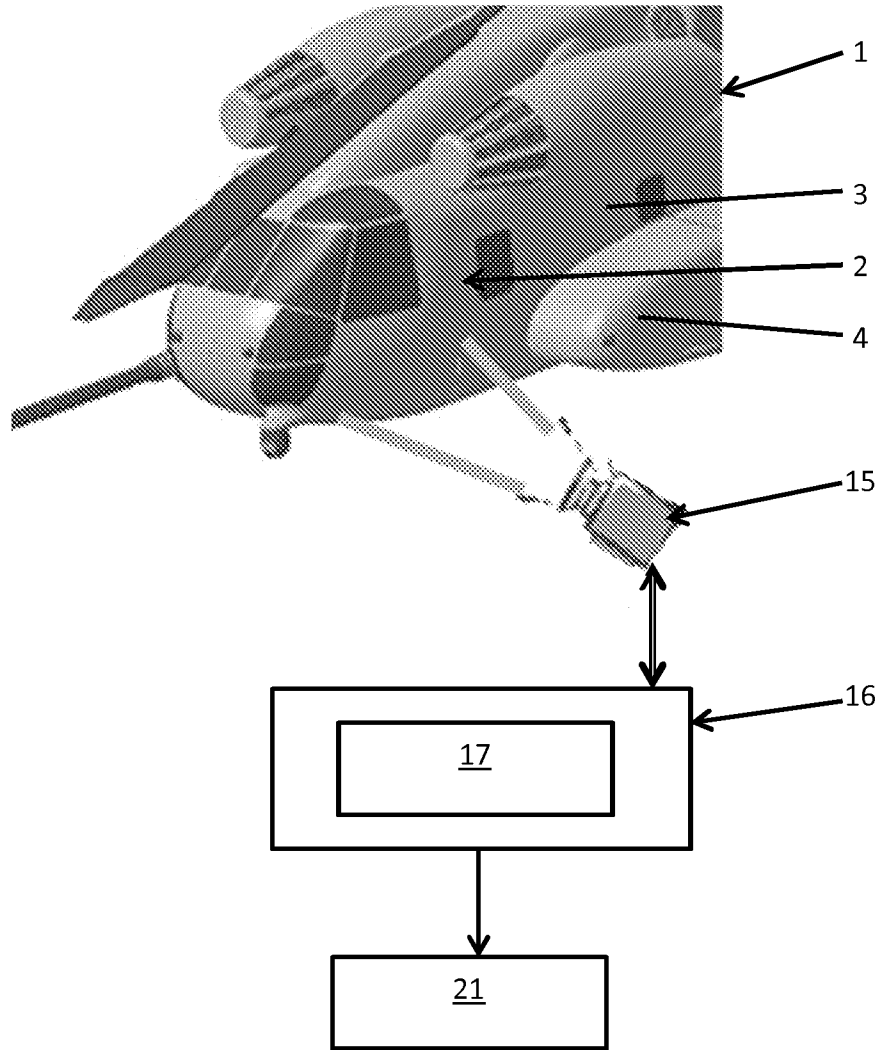

FIG. 2

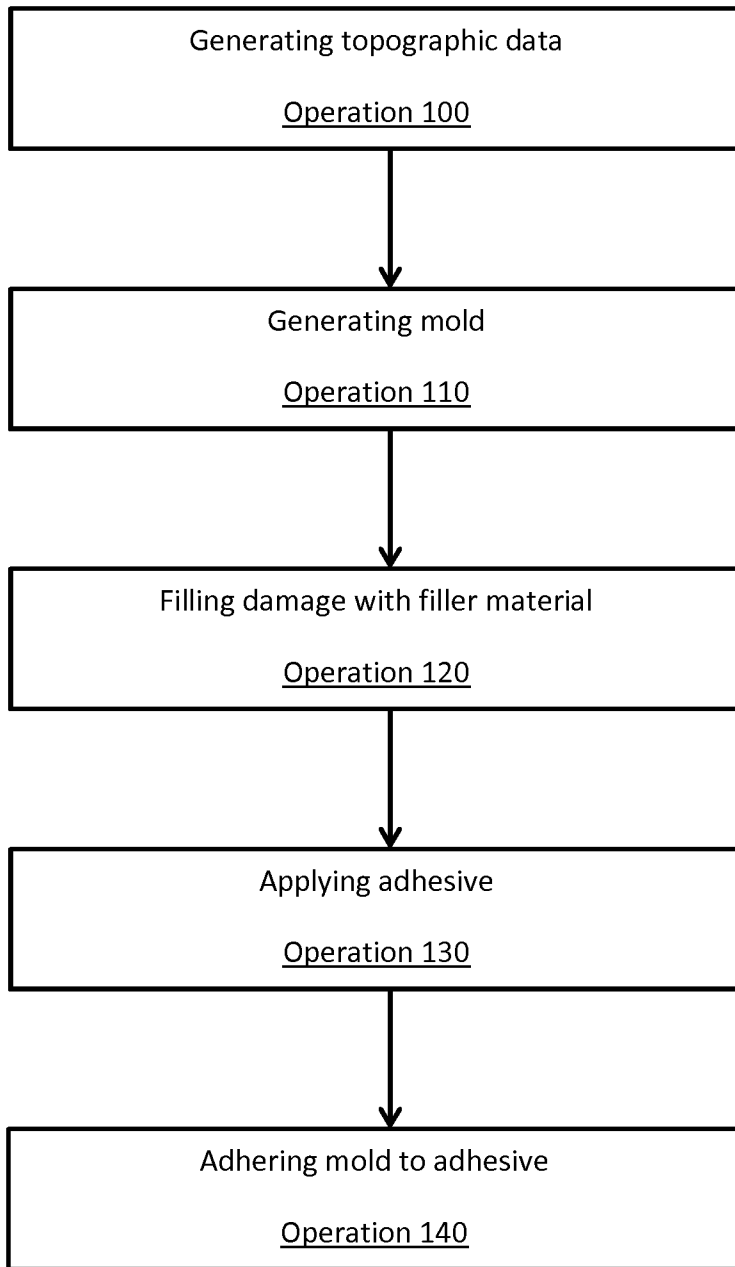

FIG. 3

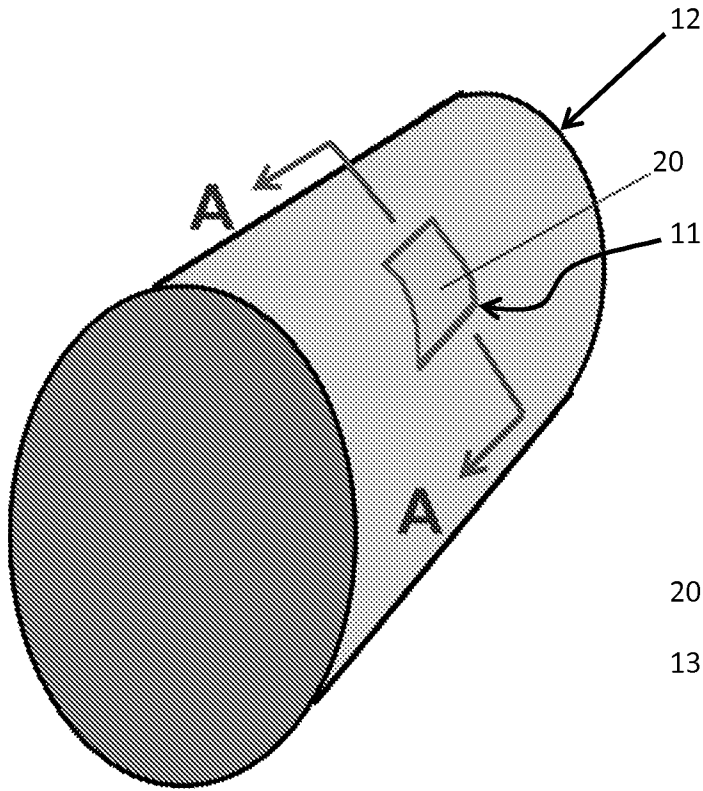
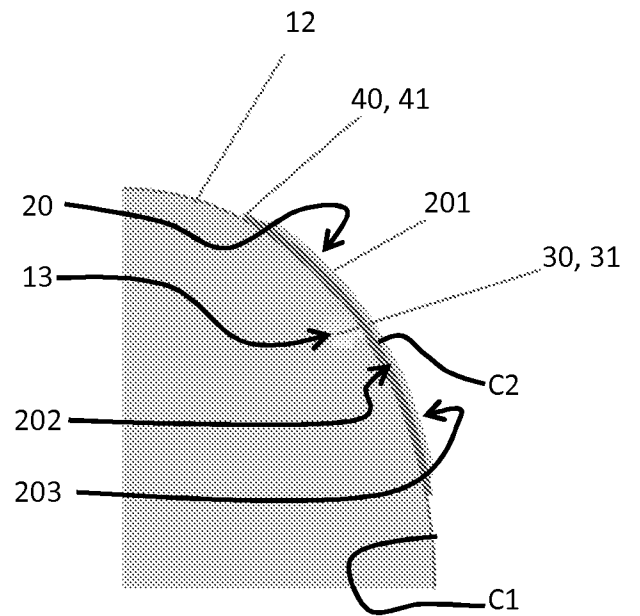

FIG. 4



INTERNATIONAL SEARCH REPORT

International application No.

PCT/US15/11576

A. CLASSIFICATION OF SUBJECT MATTER
 IPC(8) - B23P 6/00, 6/04; B64F 5/00 (2015.01)
 CPC - B64F 5/00, 5/0045, 5/0081
 According to International Patent Classification (IPC) or to both national classification and IPC

B. FIELDS SEARCHED
 Minimum documentation searched (classification system followed by classification symbols)
 IPC(8) - B23P 6/00, 6/04; B64F 5/00; B29C 70/00, 70/68 (2015.01)
 CPC - B23P 6/00, 6/04, B64F 5/00, 5/0045, 5/0081; B29C 70/00; USPC - 29/402.09; 244/119, 123.5

Documentation searched other than minimum documentation to the extent that such documents are included in the fields searched

Electronic data base consulted during the international search (name of data base and, where practicable, search terms used)
 PatSeer (US, EP, WO, JP, DE, GB, CN, FR, KR, ES, AU, IN, CA, INPADOC Data); ProQuest; IEEE; Google Scholar;
 adhesive, filler, carbon, graphite, epoxy, fiberglass, patch, aircraft, topography, scanning

C. DOCUMENTS CONSIDERED TO BE RELEVANT

Category*	Citation of document, with indication, where appropriate, of the relevant passages	Relevant to claim No.
X --- Y	US 2009/0282664 A1 (HOLZHUTER, D et al.) 19 November 2009; abstract; figure 8; paragraphs [0001], [0008], [0014]-[0019], [0046]-[0047]	1-2, 4, 8-9, 11, 15 ----- 3, 5-7; 10, 12-14
Y	US 2009/0154775 A1 (LEA, SW et al.) 18 June 2009; abstract; figure 8; paragraphs [0026], [0032][0039]	3, 7, 10, 14
Y	US 7,325,771 B2 (STULC, JF et al.) 05 February 2008; abstract; column 5, lines 3-5	5, 12
Y	US 2013/0152389 A1 (CAPPELLI, MD et al.) 20 June 2013; paragraph [0017]	6, 13
A, Y	US 2009/0234616 A1 (PERKINS, FW) 17 September 2009; entire document	1-15

Further documents are listed in the continuation of Box C. See patent family annex.

* Special categories of cited documents:
 "A" document defining the general state of the art which is not considered to be of particular relevance
 "E" earlier application or patent but published on or after the international filing date
 "L" document which may throw doubts on priority claim(s) or which is cited to establish the publication date of another citation or other special reason (as specified)
 "O" document referring to an oral disclosure, use, exhibition or other means
 "P" document published prior to the international filing date but later than the priority date claimed
 "T" later document published after the international filing date or priority date and not in conflict with the application but cited to understand the principle or theory underlying the invention
 "X" document of particular relevance; the claimed invention cannot be considered novel or cannot be considered to involve an inventive step when the document is taken alone
 "Y" document of particular relevance; the claimed invention cannot be considered to involve an inventive step when the document is combined with one or more other such documents, such combination being obvious to a person skilled in the art
 "&" document member of the same patent family

Date of the actual completion of the international search: 26 March 2015 (26.03.2015)
 Date of mailing of the international search report: 10 APR 2015

Name and mailing address of the ISA/
 Mail Stop PCT, Attn: ISA/US, Commissioner for Patents
 P.O. Box 1450, Alexandria, Virginia 22313-1450
 Facsimile No. 571-273-3201
 Authorized officer: Shane Thomas
 PCT Helpdesk: 571-272-4300
 PCT OSP: 571-272-7774