



(12) **EUROPEAN PATENT APPLICATION**

(43) Date of publication: **05.10.2005 Bulletin 2005/40**
 (51) Int Cl.7: **A44B 19/16, B65D 33/25**
 (21) Application number: **05075609.7**
 (22) Date of filing: **05.07.2001**

(84) Designated Contracting States:
**AT BE CH CY DE DK ES FI FR GB GR IE IT LI LU
MC NL PT SE TR**

(72) Inventor: **Offa-Jones, Martin John Charles
Whitby North Yorkshire YO22 5HE (GB)**

(30) Priority: **11.07.2000 GB 0016894**

(74) Representative: **W.P. Thompson & Co.
Eastcheap House
Central Approach
Letchworth Garden City,
Hertfordshire SG6 3DS (GB)**

(62) Document number(s) of the earlier application(s) in
accordance with Art. 76 EPC:
01943704.5 / 1 299 288

Remarks:

This application was filed on 14 - 03 - 2005 as a
divisional application to the application mentioned
under INID code 62.

(71) Applicant: **Supreme Plastics Holdings Limited
London N3 2TL (GB)**

(54) **Reclosable fasteners for plastics bags and other containers**

(57) A zipper (10) for application to a film or web using cross-web techniques comprises two interengageable elements (12, 14), each having engageable hooks (20, 22), and each having an upstanding post (24) at the margin of the fastener which is engageable with a heel

(28) at the opposing margin of the other element, with the respective posts (24) and heels (28) being complementarily angled (26) at their respective contact surfaces. This enables the closure more easily to resist pressure without distortion.

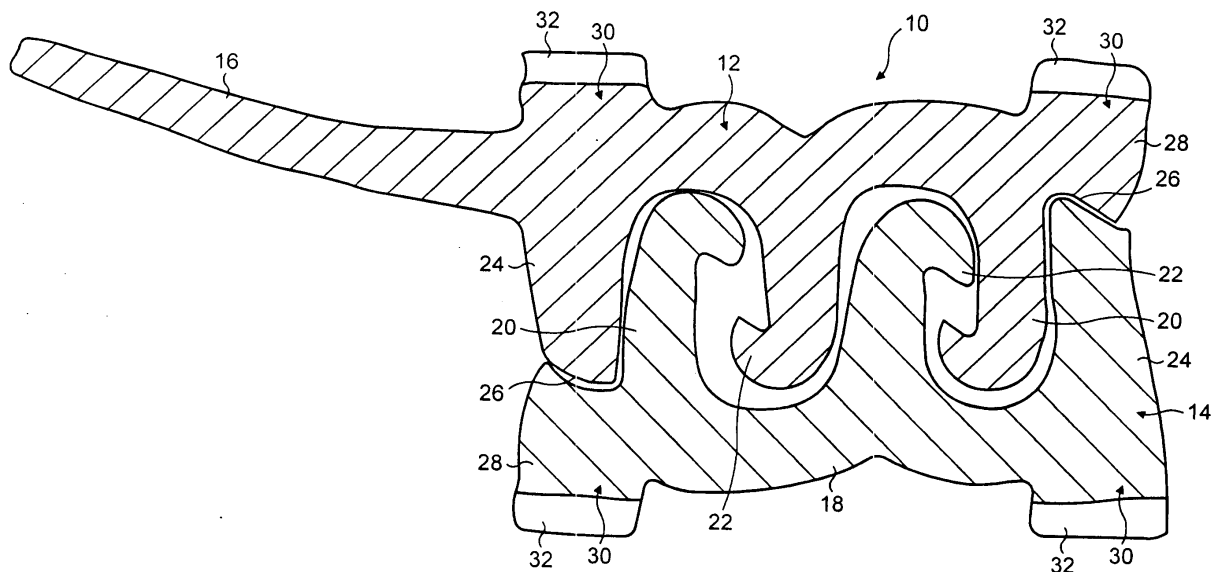

Description

Field of the invention

[0001] This invention relates to reclosable fasteners, otherwise known as zippers, for plastics bags and other containers, and is particularly concerned with zippers intended to be applied to a film or web using cross-web techniques.

Background to the invention

[0002] When a zipper strip is applied to a film or web, heat and pressure are applied to effect the welding of the zipper to the film or web. The heat and/or the pressure can result in damage to the closure. Various measures have been adopted to try to minimise the effects of the heat and pressure. However, it can still happen that the zipper is damaged or distorted as a result of these external influences.

Summary of the invention

[0003] It is an object of the present invention to provide an improved design of zipper which is resistant to distortion or damage due to the welding heat and/or pressure.

[0004] In accordance with the present invention there is provided a reclosable fastener for plastics bags and other containers, comprising two elements, each element comprising at least one portion releasably engageable with a portion of the other element, and each element comprising an upstanding post at the margin of the fastener which is engageable with a heel of the other element at the opposing margin of said other element, wherein the respective posts and heels of the two elements are complementarily angled at their respective contact surfaces.

[0005] The fact that the respective contact surfaces of the posts and heels are angled or mitred enables the closure more easily to resist pressure without distortion and without the hooks being squashed. The margins of the closure are more easily able to resist bending and to maintain their desired supporting function.

[0006] The releasably engageable portions are preferably hooked portions.

[0007] Preferably, each of the elements of the closure is provided with two hooks, engageable with the hooks of the other element.

[0008] In a preferred embodiment of the invention, and with a view particularly to resisting distortion or damage due to heat, each of the elements is provided at or adjacent to its margins, on the face remote from the hook or hooks, with a pair of protruding ribs which provide additional bulk at these marginal zones. The ribs are preferably overlaid each with a layer of high performance sealing/welding material, such as EVA for example.

[0009] In a preferred embodiment of the invention, a single long flange is provided on one only of the two interengageable elements of the closure, this flange being arranged to face the inside of the bag and being used for initial attachment to the film or web.

Brief description of the drawings

[0010] In order that the invention may be more fully understood, one presently preferred embodiment of zipper in accordance with the invention will now be described by way of example and with reference to the accompanying drawing which is a schematic cross-sectional view through the zipper.

Description of the preferred embodiment

[0011] Referring to the drawing, there is shown a zipper, indicated generally at 10, comprising a first element 12 and a second element 14. The two elements 12 and 14 are generally the same as each other, apart from the fact that element 12 is provided with a single elongate flange 16. Each element 12, 14 comprises a body portion 18 with two upstanding legs 20 which terminate in hooks 22. The respective hooks 22 of the two elements 12 and 14 are interengageable to make the reclosable fastener.

[0012] Each element 12, 14 also comprises an upstanding support post 24 at one margin. The support post 24 is slightly longer than the hooked legs 20, 22 so that it extends slightly beyond the tops of the legs. The upper end surface 26 of each post 24 is tapered to provide an angled contact surface. Facing each support post 24, on the opposing element, there is provided a heel portion 28, again at the margin. The surface of each heel portion 28 facing the respective post 24 is shaped, i.e. angled, to be complementary to the angled contact surface 26. As can be seen from the drawing, with this arrangement, the respective posts and heels nest with one another to provide a shape-locking configuration which tends to resist squashing or outward bending under vertical loads. The angled contact surfaces are able to absorb the welding pressure and maintain their linear integrity, thus preventing the hooked legs 20, 22 from being squashed or distorted.

[0013] In order to reduce the effects of the welding heat, each of the closure elements 12 and 14 is provided with a pair of ribs 30 on the outside face remote from the legs 20. The respective ribs 30 are provided again at the margins of the closure, in alignment with the posts 24 and heel portions 28. The ribs 30 are provided by a thickening of the material of which each of the two elements is composed. Because of the additional bulk provided by the ribs 30, they also contribute to the resistance of the closure to deformation due to pressure. On each rib 30 there is provided a layer 32 of a material which is a high-performance sealing/welding material or blend of materials, such as EVA for example. This facil-

itates the welding of the zipper to the encompassing web or film (not shown). The layers 32 are co-extruded with the closure elements 12 and 14.

[0014] The single long flange 16 which is part of element 12 is arranged to face the inside of the bag or container. This flange is used for initial attachment to the film or web as the zipper is applied to the web by a cross-web technique. The provision of a single long flange provides increased internal strength to the bag by altering the angle at which the load in the bag acts against the zipper closure.

The following clauses define aspects of this invention:

1. A reclosable fastener for plastics bags and other containers, comprising two elements, each element comprising at least one portion releasably engageable with a portion of the other element, and each element comprising an upstanding post at the margin of the fastener which is engageable with a heel of the other element at the opposing margin of said other element, wherein the respective posts and heels of the two elements are complementarily angled at their respective contact surfaces.

2. A reclosable fastener as claimed in claim 1, in which the releasably engageable portions are hooked portions.

3. A reclosable fastener as claimed in claim 1 or 2, in which each of the elements is provided with two hooks, engageable with the hooks of the other element.

4. A reclosable fastener as claimed in claim 1, 2 or 3, in which each of the elements is provided at or adjacent to its margins, on the face remote from the hook or hooks, with a pair of protruding ribs.

5. A reclosable fastener as claimed in claim 4, in which each of the ribs is overlaid with a layer of sealing/welding material.

6. A reclosable fastener as claimed in claim 5, in which the sealing/welding material is EVA.

7. A reclosable fastener as claimed in any preceding claim, in which a single flange is provided on one only of the two interengageable elements of the fastener, for attachment to a film or web.

complementarily angled at their respective contact surfaces (26) wherein, when the elements are engaged with each other, the engagement between the posts and heels at their angled contact surfaces is such as to prevent distortion of the releasably engageable portions of the fastener elements under application of a load urging the elements together.

2. A reclosable fastener as claimed in claim 1, in which the releasably engageable portions are hooked portions (22).

3. A reclosable fastener as claimed in claim 1 or 2, in which each of the elements is provided with two hooks (22), engageable with the hooks (22) of the other element.

4. A reclosable fastener as claimed in any preceding claim, in which the body portion of each of the elements (12, 14) is provided at or adjacent to its margins, on the face remote from the hook or hooks, with a pair of protruding ribs (30).

5. A reclosable fastener as claimed in claim 4, in which each of the ribs (30) is overlaid with a layer (32) of sealing/welding material.

6. A reclosable fastener as claimed in claim 5, in which the sealing/welding material (32) is EVA.

7. A reclosable fastener as claimed in any preceding claim, in which a single flange (16) is provided on one only of the two interengageable elements (12) of the fastener (10), for attachment to a film or web.

Claims

1. A reclosable fastener (10) for plastics bags and other containers, comprising two elements (12, 14), each element comprising at least one portion (20, 22) releasably engageable with a portion (20, 22) of the other element, **characterised in that** each element comprises a body portion and a post (24) at the margin of the fastener which is upstanding from the body portion and is engageable with a heel (28) on the body portion of the other element at the opposing margin of said other element, wherein the respective posts and heels of the two elements are

