



- (51) **International Patent Classification:**  
A47J 43/27 (2006.01) B65D 51/28 (2006.01)
- (21) **International Application Number:**  
PCT/CA2024/050821
- (22) **International Filing Date:**  
17 June 2024 (17.06.2024)
- (25) **Filing Language:** English
- (26) **Publication Language:** English
- (30) **Priority Data:**  
63/508,642 16 June 2023 (16.06.2023) US
- (71) **Applicant: 13698947 CANADA INC.** [CA/CA]; 28 rue  
Chaumont, Blainville, Québec J7B 6B5 (CA).
- (72) **Inventor: DESORMEAUX, Jean-francois;** 3635 av Jean-  
Beraud, Laval, Québec J7B 6B5 (CA).
- (74) **Agent: EQUINOX IP INC.;** 1555, boul. Of the Future,  
Suite 306, Laval, Québec H7S 2N5 (CA).
- (81) **Designated States** (unless otherwise indicated, for every  
kind of national protection available): AE, AG, AL, AM,  
AO, AT, AU, AZ, BA, BB, BG, BH, BN, BR, BW, BY, BZ,  
CA, CH, CL, CN, CO, CR, CU, CV, CZ, DE, DJ, DK, DM,  
DO, DZ, EC, EE, EG, ES, FI, GB, GD, GE, GH, GM, GT,

HN, HR, HU, ID, IL, IN, IQ, IR, IS, IT, JM, JO, JP, KE, KG,  
KH, KN, KP, KR, KW, KZ, LA, LC, LK, LR, LS, LU, LY,  
MA, MD, MG, MK, MN, MU, MW, MX, MY, MZ, NA,  
NG, NI, NO, NZ, OM, PA, PE, PG, PH, PL, PT, QA, RO,  
RS, RU, RW, SA, SC, SD, SE, SG, SK, SL, ST, SV, SY, TH,  
TJ, TM, TN, TR, TT, TZ, UA, UG, US, UZ, VC, VN, WS,  
ZA, ZM, ZW.

(84) **Designated States** (unless otherwise indicated, for every  
kind of regional protection available): ARIPO (BW, CV,  
GH, GM, KE, LR, LS, MW, MZ, NA, RW, SC, SD, SL, ST,  
SZ, TZ, UG, ZM, ZW), Eurasian (AM, AZ, BY, KG, KZ,  
RU, TJ, TM), European (AL, AT, BE, BG, CH, CY, CZ,  
DE, DK, EE, ES, FI, FR, GB, GR, HR, HU, IE, IS, IT, LT,  
LU, LV, MC, ME, MK, MT, NL, NO, PL, PT, RO, RS, SE,  
SI, SK, SM, TR), OAPI (BF, BJ, CF, CG, CI, CM, GA, GN,  
GQ, GW, KM, ML, MR, NE, SN, TD, TG).

**Published:**

- with international search report (Art. 21(3))
- in black and white; the international application as filed  
contained color or greyscale and is available for download  
from PATENTSCOPE

(54) **Title:** A SHAKER BOTTLE FOR USE WITH POWDER DISPENSER

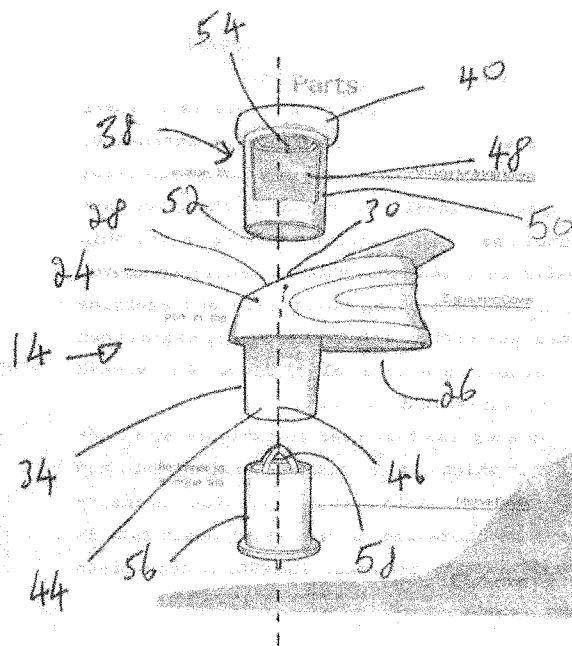

FIG. 3

(57) **Abstract:** An apparatus for mixing powder and fluid. The apparatus includes a bottle sized and shaped to receive therein an amount of fluid. The bottle has an upper bottle end and a lower bottle end. An over mold ring member circumferentially connected to the upper bottle end. A bottle cap connected to the over mold ring member, the bottle cap has a centrally disposed resilient portion. A bottle lid with a bottle lid connector extends over the centrally disposed resilient portion. The bottle lid is sealingly and removably connected to a mouthpiece. A handle member is connected to the bottle cap. The handle member is sized and shaped for holding during a powder release operation.



## A SHAKER BOTTLE FOR USE WITH POWDER DISPENSER

### TECHNICAL FIELD

The present generally concerns an apparatus for mixing beverages, and more particularly a cutting system for puncturing a powder-containing pod to dispense the powder for mixing.

### BACKGROUND

In one sector of the beverage industry, beverage can be prepared before consumption by mixing powdered ingredients such as protein, vitamin, and mineral supplements, or any mixture thereof, with water or some other liquid.

Generally speaking, the powdered ingredients are supplied in a bottle or in some cases a large tub and require a spoon or a scoop to transfer the powder to the bottle where either water is first located or is added after the powder is added. Conventional mixers require a scoop to collect an amount of powder from a large container and place this scooped powder into a bottle. Once the powder and the liquid are combined in the container, the user shakes the container so as to either evenly disperse the powder in the liquid, if a shake is being produced, or dissolved if the powder is fully soluble. The container, which is typically a hand-held bottle container includes a top cover which has either a drinking spout or, when the top cover is removed, can drink directly from the bottle.

While this arrangement is seemingly quick and easy, there are a number of clear drawbacks. This can be a messy operation, especially if the user misjudges the transfer of the powder. Also, it is inconvenient for the user to mix the powder anywhere since they must carry a large container of powder and the scoop. It is also likely that the large container of powder may become contaminated or may spoil, especially if the powder is sensitive to light or air. Furthermore, the use of a large container can result in losses of material especially as the amount of powder decreases over time. The residual powder is often found compacted in the edges of the container, which is wasteful.

A number of groups have identified these problems and have endeavored

to address them using a number of designs, several of which are provided below:

Published United States patent application number US 2017/0129665,  
publication date May 11 2017;

Published German patent (English translation) number DE  
5 102019125582, publication date September 24, 2019.

While these designs do provide alleviation of some of the problems with  
convention designs, they also have a number of drawbacks which limits their use. The  
designs disadvantageously appear overly complex to both use and manufacture. This  
would likely be prohibitively expensive for large scale manufacture. Also, with the  
10 designs above, the problem remains of accurately loading the powder first into a pod or  
capsule. Furthermore, cutting the powder-containing capsule accurately so that all of  
the powder is released would still be a problem thereby reducing the efficiency of the  
process.

Thus, there is a need for an apparatus to quickly and efficiently mix a  
15 power with a liquid in a bottle container. A pre-sealed pod that contains an accurately  
measured amount of powder that can be mixed with the liquid on a need-to-use basis  
would of course address the above-noted disadvantages.

#### BRIEF SUMMARY

We have designed a cutting apparatus that is useful to piece the wall of a  
20 container in which a predetermined amount of powder material is contained so that is  
can be quickly released into a bottle container without loss of the powder due to spillage.  
This significantly reduces, or essentially eliminates, the problems associated with  
conventional designs. Our novel and unobvious design uses one or more cutting  
members that are disposed opposite each other in a lid so that a user when he/she  
25 applied an inwardly directed force engages both sets of blades so that the pod  
containing the powder is efficiently pieces. The powder then drops into the liquid  
contained in the bottle so that the user may quickly shake the contents to thoroughly  
mix them without clumping or residues from the pod casing.

Accordingly, in one embodiment there is provided an apparatus for  
30 mixing powder and fluid, the apparatus comprising:

a bottle sized and shaped to receive therein an amount of fluid, the bottle having an upper bottle end and a lower bottle end;

an over mold ring member circumferentially connected to the upper bottle end;

5 a bottle cap connected to the over mold ring member, the bottle cap having a centrally disposed resilient portion;

a bottle lid with a bottle lid connector extending over the centrally disposed resilient portion, the bottle lid being sealingly and removably connected to a mouthpiece; and

10 a handle member connected to the bottle cap, the handle member being sized and shaped for holding during a powder release operation.

In one example, the apparatus includes a mouthpiece moveable towards and away from a seating position, the mouthpiece being configured such that after a mixing operation is complete, the user flips up the mouthpiece to access  
15 to the mixed drink via a fluid passageway, the fluid passageway being located to communicate the interior of the bottle with a user's mouth.

In one example, the bottle includes an exterior sidewall having an anti-slip surface.

In one example, the bottle includes a mixing chamber and a mixing  
20 chamber floor, a plurality of crossed fingers extending from the mixing chamber floor, the mixing chamber being sized and shaped to receive therein a predetermined amount of a powder, the mixing chamber being sealingly connected to an inner portion of the bottle. The powder is a protein powder, a powdered drink mix.

25 In one example, a re-usable pod is located in the shaker, the re-useable pod having a pred-determined amount of a powder therein, the pod having a contact portion to receive thereagainst a releasing force to disengages the mixing chamber from the shaker thereby releasing the powder by gravity into the bottle for shaking.

In one example, the apparatus includes a single serve pod, the pod  
30 having a knife member mounted inside the pod. A two-layer membrane is sealed to

a bottom edge of the pod. A knife is located inside two chambers of the pod.

In one example, the bottle includes a plurality of magnets connected to the outer sidewall for holding a plurality of bags.

Accordingly, in another embodiment there is provided a powder  
5 dispenser for use with a bottle, comprising:

a lid body having distal and proximal end portions, and a lid body opening extending between the end portions, the lid body being connectable to a bottle rim;

an insert receiving member located adjacent the distal end portion and  
10 connected to the lid body opening, the insert receiving member communicating with an interior of the bottle; and

a pod holding member for snugly holding therein a powder-containing pod, the pod holding member having a pushing end portion, the pod holding member being cooperable with the insert receiving member, the pod  
15 holding member being adapted to cut the pod, so that a pushing force when applied to the pushing end portion pushes the pod holding member into the insert receiving member to cut the pod so as to release the powder therefrom into the bottle.

In one example, the insert receiving member includes a downwardly depending sleeve, the sleeve being sized and shaped to permit the pod holding  
20 member to slidably insert into the insert receiving member. The sleeve depends downwardly along a longitudinal bottle axis.

In on example, the pod holding member is a first cylindrical chamber having a side opening in a chamber sidewall and a lower opening in communication with the interior of the bottle to guide the powder into the bottle when released from  
25 the pod. The pod holding member includes a pushing end portion having a first cutting member connected thereto and depending therefrom. The first cutting member includes one or more blades.

In one example, the sleeve is sized to cooperate with the pod holding member.

30 In another example, a cylindrical insert cutting member is cooperable

with the insert receiving member and is disposed coaxially with the pod holding member. The cylindrical insert cutting member includes one or more blades.

In yet another example, a first cylindrical chamber includes a pushing end portion having a first cutting member connected thereto and depending therefrom; and a cylindrical insert cutting member is cooperable with the insert receiving member and is disposed coaxially with the pod holding member so that a pushing force when applied to the pushing end portion pushes the first cutting member towards the cylindrical insert cutting member to cut the pod so as to release the powder therefrom into the bottle. The cylindrical insert cutting member has a diameter smaller than the first cylindrical chamber.

In yet another example, the sleeve is angled away from a bottle sidewall. The pod holding member is a first cylindrical chamber having a side opening in a chamber sidewall and a lower opening in communication with the interior of the bottle to guide the powder into the bottle when released from the pod. The pod holding member includes a pushing end portion. A cylindrical cutting member is located adjacent the distal end portion and connected to the lid body opening, the cylindrical cutting member being cooperable with the pod holding member and is disposed coaxially therewith so that a pushing force when applied to the pushing end portion pushes the pod holding member towards the cylindrical cutting member to cut the pod so as to release the powder therefrom into the bottle. The cylindrical cutting includes one or more blades. The pod holding member has a diameter smaller than the diameter of the cylindrical cutting member.

In still another example, the dispenser further includes a hinged closing cap to cover the lid body opening.

In one example, the pod is generally cylindrical-shaped.

In yet another example, the powder is a protein powder, a milk powder, coffee powder, tea powder, juice powder, vitamin mix, aloe gel, any type of gel, and the like.

In yet another example, the bottle contains an amount of a liquid.

In yet another example, the pod includes a predetermined amount of

the powder.

In one example, the pod is a self-perforating pod.

In another example, the pod is a compressible bag which ruptures when a force is applied thereto.

5 In one example, the pod includes an aluminum lid.

In another example, the lid body includes a resilient bump member for holding the pod in the bottle. The resilient bump member is located to engage a circular knife with the pod so as to release the powder located therein.

10 In yet another example, the pod includes an integrated clip configured to snappingly engage onto a shaft member, the shaft member being connected to a resilient bump member.

In still another example, the pod includes two or more clips located to hold the pod in the lid body using an interference fit.

15 Accordingly, in another embodiment there is provided a re-useable shaker pod apparatus for use with a bottle having a bottle cap comprising

a mixing chamber having a floor sealingly mounted in the bottle cap;

a plurality of projections connected to the floor and extending away therefrom, the projections being surrounded by a mixing chamber sidewall, the projections being angled towards each other; and

20 a resilient member in communication with the mixing chamber and located to contact the projections, the resilient member being located to receive thereagainst an actuating force applied by an actuating handle, the actuating handle being hingeably connected to the bottle cap, the actuating force being sufficient to push the mixing chamber into the bottle so as to gravitationally release an amount  
25 of powder located in the mixing chamber.

In one example, the mixing chamber includes crossed fingers connected to a mixing chamber floor. The handle includes a hinge to hingeably connect the handle to the cap, the handle having a curved contacting portion of a size sufficient to apply a force to the resilient portion. The projections include  
30 crossed fingers connected to the mixing chamber floor and extending away

therefrom,

Accordingly, in another embodiment there is provided a re-useable pod for a drink mixer bottle, the pod comprising:

5 a pod mixing chamber having a predetermined amount of a powder located therein, the chamber being engageable with an upper portion of the drink mixer bottle, the chamber being sealed against the upper portion of the bottle;

a contact portion located on a pod surface away from the mixing chamber, the contact portion being located to receive thereagainst a releasing force; and

10 a mixing floor having a plurality of projections extending away therefrom, the mixing floor being released when a hingeably actuating handle applies the releasing force against the contact portion to move the mixing floor into the bottle thereby gravitationally releasing the powder into the bottle.

#### **BRIEF DESCRIPTION OF THE DRAWINGS**

15 These and other features of that described herein will become more apparent from the following description in which reference is made to the appended drawings wherein:

**Fig.1** is a side view of an embodiment of a container showing a lid and a first upper insert loaded with a pod sliding into the lid;

20 **Fig.2** is a series of close-up views of the steps of loading a pod into the first upper insert and using a hand to push the insert into the lid;

**Fig.3** is a perspective exploded view of a cutting apparatus showing the upper insert with a set of blades, a lower insert with a set of blades and a lid with a downwardly projecting sleeve;

25 **Fig.4** is a side view of another embodiment of a container showing the sequence of steps which include 1) opening a lid door and positioning a pod-containing insert near a lid opening, 2) pushing the insert into the lid opening and pushing thereagainst, 30 closing the lid door and shaking the liquid/powder mixture;

**Figs. 5A, 5B and 5C** are close-up side views of embodiments of three self-perforating pods;

30

- Fig. 6** illustrates an embodiment of a compressed “pod” bag design;
- Figs. 7A and 7B** illustrate a close-up partially cut through view of a downwardly disposed knife for cutting a pod;
- Fig. 8** illustrates a perspective view and a side view of a bumped pod embodiment;
- 5 **Fig. 9A** is a longitudinal section view of a bumped pod showing the location of the bump before activation;
- Fig. 9B** is a longitudinal section view of a bumped pod showing the location of the bump after the powder is released;
- Fig. 10** is a schematic representation of the bumped pod showing (A) the location of a circular cutting knife when viewed in cross section; (B) the cutting knife when viewed from above; and (C) a close-up cross section view showing the shape of the knife;
- 10 **Fig. 11** is a series of longitudinal cross-sectional views of a clipped pod embodiment showing pods of three different sizes (A), (B), (C);
- 15 **Fig. 12A** is a longitudinal cross-sectional view of the clipped pod showing the direction of a push force before activation;
- Fig. 12B** is a longitudinal cross-sectional view of the clipped pod showing the configuration after powder is released;
- Fig. 13** is a longitudinal cross-sectional view of an embodiment of a dispenser with a live hinge showing the location of knives and a pod;
- 20 **Fig. 14** is a longitudinal cross-sectional view of an alternative embodiment of a dispenser with a live hinge;
- Fig. 15** is a longitudinal cross-sectional view of an alternative embodiment of a dispenser with a live hinge showing a sticking rod located for perforating a pod;
- 25 **Fig. 16** is a longitudinal cross-sectional view of a pod having clips connected thereto;
- Fig. 17** is a perspective view of the pod of Fig. 16 showing the location of two clips;
- Fig. 18** is a perspective view of an alternative embodiment of a shaker bottle showing a cap arrangement and a hinged actuator handle;
- 30 **Fig. 19** is a cross sectional view of pod-less mixing chamber;

**Fig. 20** is a cross sectional view of the pod-less mixer of Fig. 19 in which the mixing device is released;

**Fig. 21** is a top perspective view of the pod-less mixer showing location of the mixing device;

5 **Fig. 22** is a cross sectional view of a re-useable pod showing the mixing device;

**Fig. 23** is a cross sectional view of a sequence in which: A: the re-useable pod is located in the shaker; B: the actuating handle engages with the pod; and C: the pod is released by gravity into the bottle;

10 **Fig. 24** is an exploded perspective view of two single serve pods showing an arrangement of knives;

**Fig. 25** is a number of views showing the single serve pod being loaded and punctured by application of an actuating force;

**Fig. 26** is a perspective view of an actuating handle in operation;

15 **Fig. 27** is a perspective view of an alternative embodiment of a shaker bottle showing a cap arrangement and a hinged actuator handle;

**Fig. 28** is a longitudinal cross-sectional view of the shaker bottle of Fig. 27;

**Fig. 29** illustrates two longitudinal cross-sectional views of the bottle of Fig. 27 in a powder dispensing operation;

20 **Fig. 30** illustrates a cross-sectional, close up view of a spring-loaded closure of the bottle cap;

**Fig. 31** is a close-up view of a safety mechanism;

**Fig. 32** is a close up view of a knife member;

**Fig. 33** is a cross sectional view showing the location of the knife member;

**Fig. 34** is a cross sectional view of a powder release mechanism;

25 **Fig. 35 A through D** illustrates a number of pod (capsule) arrangements;

**Fig. 36** is a perspective view of a bag holding and phone holding system; and

**Fig. 37** illustrates a number of views showing the bag holding system.

## DETAILED DESCRIPTION

### Definitions

30 Unless otherwise specified, the following definitions apply:

The singular forms “a”, “an” and “the” include corresponding plural references unless the context clearly dictates otherwise.

As used herein, the term “comprising” is intended to mean that the list of elements following the word “comprising” are required or mandatory but that  
5 other elements are optional and may or may not be present.

As used herein, the term “consisting of” is intended to mean including and limited to whatever follows the phrase “consisting of”. Thus, the phrase “consisting of” indicates that the listed elements are required or mandatory and that  
10 no other elements may be present.

Referring to Figs 1 through 3 there is shown generally at 10 a dispensing apparatus for piercing a powder-containing pod 12 that is held in a lid 14 of a drinking bottle 16. The dispensing apparatus 10 can be viewed therefore as a powder dispenser. The pod 12 is generally cylindrical shaped. A person of ordinary skill in the art will recognize that although the pod 12 is illustrated as cylindrical-  
15 shaped, any shape of pod can be used. In fact, the pods can include multiple stages or stories to hold different powders in each stage.

The powder is, by way of example, a protein powder, a milk powder, coffee powder, tea powder, juice powder, vitamin mix, aloe gel, any type of gel, and the like. Of course, a person of ordinary skill in the art will recognize that there are  
20 a large variety of powders which can be used in this design.

One advantage our apparatus has over conventional mixer bottles is that the pod 12 can be manufactured to hold a predetermined amount of the powder. Furthermore, as material science improves, our pods may be made from plastics, and bioplastics, such as PLA and hemp-plastic, which are environmentally friendly.

In the example shown, the drinking bottle 16 is the type generally used for recreational purposes and is shaped to be hand-held. The lid 14 is ergonomically shaped and includes a spout 18 from which the beverage is dispensed. The drinking bottle 16 is also of a size and shape that permits a user to shake the bottle 16 once a powder has been loaded therein so as to quickly and efficiently mix the powder with  
25 the liquid just prior to consumption. The lid 14 includes a screw 20 for securing the  
30

lid 14 to the bottle 16. Generally, this is done to create a water-tight fit to prevent leakage of the beverage. The bottle 16 is sized to contain an amount of a liquid such as water.

Referring now specifically to Figs 2 and Fig. 3, the lid 14 includes a lid  
5 body 24 that has a distal end portion 26 and a proximal end portion 28. A lid body opening 30 extends between the end portions 26, 28. In the example shown, the lid body 24 is designed to be connectable to a bottle upper rim by a screwing engagement. A person of ordinary skill in the art will also recognize that the lid 14 may also be connected to the bottle 16 using an interference fit or indeed any type of  
10 connector for making a temporary water-tight seal. Broadly speaking, an insert receiving member 34 is located adjacent the distal end portion 26 and is connected to the lid body opening 30. The insert receiving member 34 is designed to communicate with an interior 36 of the bottle 16. A pod holding member 38 holds the powder-containing pod 12 in a snug fit. The pod holding member 38 includes a  
15 pushing end portion 40 and is sized and shaped to cooperate with the insert receiving member 34.

As best seen in the sequence in Fig. 2, the pod holding member 38 is adapted to cut the powder-containing pod 12, so that a pushing force 42 when applied to the pushing end portion 40, the pod holding member 38 is pushed into  
20 the insert receiving member 34 to cut the powder-containing pod 12, which releases the powder therefrom into the bottle 16. After this, the user then shakes the bottle 16 to mix the contents prior to consumption.

As shown in Figs. 1 through 3, the first embodiment of the apparatus shows the insert receiving member 34 having a downwardly depending sleeve 44.  
25 The sleeve 44 is generally sized and shaped to permit the pod holding member 38 to slidably insert into the insert receiving member 34 to achieve an interference fit. The sleeve 44 depends downwardly along a longitudinal bottle axis 46. The sleeve 44 in this example is generally cylindrically shaped. The pod holding member 38 is a cylindrical chamber with a side opening 48 in a chamber sidewall 50 and a lower  
30 opening 52 which is in communication with the interior of the bottle. 16. This is

designed so that the powder is guided into the bottle 16 when it is released from the pierced pod 12. At the top end, the pod holding member 38 includes the pushing end portion 40, which includes a first cutting member 54 connected to it. The first cutting member 54 depends downwardly from the pushing end portion 40. In the example shown, the first cutting member 54 includes one or more blades. To achieve an efficient and spill-free loading step, the sleeve 34 is sized to cooperate with the pod holding member 38. A cylindrical insert cutting member 56 is cooperable with the insert receiving member 34 and is disposed coaxially with the pod holding member 38 along the axis 46. The cylindrical insert cutting member 56 includes one or more blades 58. When a pushing force when applied to the pushing end portion 40 it pushes the first cutting member 54 towards the cylindrical insert cutting member 56 to cut the pod 12 so as to release the powder therefrom into the bottle 16. To allow for easy insertion, the cylindrical insert cutting member 56 has a diameter smaller than the cylindrical pod holding member 38 and the sleeve 34.

Referring now to Fig. 4, there is illustrated a sequence of loading and mixing a powder released from an alternative embodiment of a dispenser 100 as part of a lid body 102. A sleeve 104 is angled away from a bottle sidewall 106 and like the pod holding member 38 described above, a pod holding member 108 in this embodiment is a first cylindrical chamber 110 which has a side opening 112 in a chamber sidewall 114 and a lower opening 118 in communication with the interior of the bottle 16 to guide the powder into the bottle when released from the pod 12. The pod holding member 108 includes a pushing end portion 120. A cylindrical cutting member 122 is located adjacent a distal end portion 124 and is connected to a lid body opening 126. The cylindrical cutting member 122 is cooperable with the pod holding member 108 and is disposed coaxially therewith so that a pushing force 128 when applied to the pushing end portion 120 it pushes the pod holding member 108 towards the cylindrical cutting member 122 to cut the pod 12 so as to release the powder therefrom into the bottle 16. The cylindrical cutting member 122 includes one or more blades 130. The pod holding member 106 has a diameter smaller than the diameter of the cylindrical cutting member 122. The dispenser 100 further

includes a hinged closing cap 132 to cover the lid body opening.

Turning now to the pod designs. We have developed a number of designs for use in our dispenser. As best illustrated in Figs. 5A, 5B and 5C, self-perforating pods 200 are presented. The self-perforating pod 200 is a pod that is injected with a shape that permits “self-perforation” when it is pushed down from the top. Three examples of the various shaped, self-perforating pod 200 are shown in Figs 5A, 5B and 5C. In each case an aluminum lid or plastic cap 202 seals the pod at the bottom. The pod 200 can be inserted in a shaker cap and then pressed down to perforate the pod.

Turning now to an alternative pod design 300 as shown in Fig.6. The pod design 300 is a compressed bag 302 in which the powder mix is inserted into an enclosed bag (chip style). The user then compresses the bag to rupture the membrane under pressure so as to release the powder into the bottle.

Referring now to Figs. 7A and 7B, in which another embodiment of a pod design is shown at 400. In this design a single cutting member in the form of a downwardly depending knife 402 is located in the slider to cut the top and bottom membrane of the pod when pushed down.

Referring now to Figs.8 through 15, we will now describe additional embodiments of a dispenser for mixing powder with a liquid, specifically water. The embodiments described above were developed to specifically mix protein powder into water. In the following embodiments, we developed our discovery so that the apparatus can be used to mix other additives including, but not limited to, pharmaceuticals in liquids, baby formula in water, instant coffee in hot water or even powdered paint in liquid.

As we developed our dispensers, we were mindful of the environmental impact our pods might have. To this end, we advantageously developed our pods to be manufactured from either recyclable plastic or a compostable material. Generally speaking, the shaker bottle is manufactured using well-known plastic injection technology. However, the bottle can also be manufactured using a double-walled vacuum sealed thermos-type model (metal forming) so as to contain cold beverages,

such as, for example, cold brewed coffee or beverages and the like. In both cases, the bottles are re-usable and easy to clean and disinfect.

Referring now specifically to Figs. 8, 9A, 9B and 10, an embodiment of a lid body is shown generally at 500. A pod 502 includes an aluminum lid 504 that contains an amount of a powder. The pod 502 is located into the lid body 500 of a bottle 506. A resilient bump member 508 holds the pod 502 in the bottle 506. The resilient bump member 508 is a “push button” made of resilient material, such as for example, silicone and the like, located on an upper portion 510 of the lid body 500. A user has easy access to the bump member 508 and can depress the bump member 508 when needed. There are two stages of resilient bump member to hold the pod 502 inside the lid body 500 when the user removes the lid body 500 to clean it. It is easy to pull out the pod 502 from inside the lid body 500 to then dispose of it. The resilient bump members allow the use of different pod sizes and keep the pods at the same distance from the knife.

As best seen in Figs. 9A and 9B, in operation, the resilient bump member 508 pushes on the pod 502 located inside the lid body 500 which then drops on a circular knife 510 and engages the pod 502. The circular knife 510 cuts the aluminum lid 504 of the pod 502 which then releases the powder.

Referring now to Figs 11, 12A and 12B, another pod design is shown generally at 600. The pod 600 includes an integrated clip 602 that is configured to snappingly engage onto a shaft-like member 604 which is connected to a resilient push button member 606.

In operation, the pod 600 is located in a lid body 608 and snapped in place by twisting the pod 600 onto the shaft member 604. The snap on the shaft member 604 allows a number of different pod sizes and helps maintain the pods 600 at the same distance from the circular knife, as used in the example described above.

Referring now to Figs. 13, 14 and 15, another embodiment of a pod is shown generally at 700 which includes a weakened plastic cap molded with the pod 702 for insertion into the lid body. The pod 702 is perforated by a first knife 704 on

the bottleneck 706. The pod 700 is then held in place by the bottleneck 706. The shaker lid 708 is screwed on the bottle. To cut the aluminum lid, the top of the shaker lid is pressed down which cut open the lid using the second knife 710 and allows the powder to be released into the bottle. This allows the user to drink  
5 through the pod.

Alternatively, in an embodiment shown at 800, there is no bottom, second knife. The aluminum lid in this design is perforated using a rod 802 which is moved along a longitudinal axis down the bottle neck into the aluminum lid of the  
10 pod.

Referring now to Figs. 16 and 17, in another embodiment, a pod 900 includes, two or more clips 902 located on a lower portion 904 thereof. The clips 902 hold the pods in the lid body by means of an interference fit. In operation, the user pushes onto a resilient bump member 906 to drop the pod 900 onto the knife so as to perforate the aluminum lid.  
15

#### Alternative embodiments

Referring now to Figs. 18 through 26, alternative embodiments of an apparatus for mixing a powder and a fluid shaker bottle are illustrated. Firstly, an alternative shaker bottle is shown generally at 1000 which can be used using three different scenarios. Firstly, the shaker bottle 1000 can be used without a pod-  
20 containing powder; secondly, the shaker bottle 1000 can be operated using a reusable pod containing powder; and thirdly, the shaker bottle can be used with a single-serve pod.

In all three scenarios, the bottle structure 1000 is essentially identical and includes a bottle portion 1002 which is sized and shaped to receive therein an  
25 amount of fluid. In the examples used, the fluid is water. Optionally, an exterior sidewall of the bottle can include an anti-slip surface 1004 to help the user grip the bottle during use. In the example illustrated, the anti-slip surface includes a plurality of spaced apart, longitudinally disposed ridges. An over mold ring member 1006 is circumferentially connected to an upper portion 1008 of the bottle 1000. A  
30 bottle cap 1010 is connected to the over mold ring member 1006 and includes a

centrally disposed resilient portion 1012, the use of which will be described below. A bottle lid 1014 and a bottle lid connector 1016 extend over the centrally disposed resilient portion 1012. The bottle lid 1014 is sealingly and removably connected to a mouthpiece 1018. A handle member 1020 is hingeably connected to the cap 1010 and is sized and shaped to be hingeably moved relative to the resilient portion 1012 during a use operation. The mouthpiece 1018 is hingeably towards and away from a seating position, as seen in Fig. 18. When a mixing operation is complete, the user may flip up the mouthpiece 1018 and thus have access to the mixed drink via a fluid passageway which communicates the interior of the bottle with the user's mouth.

Referring now to Figs. 19 to 21, an embodiment in which the shaker bottle 1000 is used without a pod will now be described. Located in the upper portion of the bottle is a mixing device 1022 which includes a seal 1024 to sealingly connect the mixing device 1022 to an inner portion 1026 of the bottle. The mixing device 1022 is a mixing chamber 1028 that includes crossed fingers 1030 that are connected to a mixing chamber floor 1032. Before a mixing operation, the user adds a pre-determined amount of a powder such as a protein powder, a powdered drink mix and the like, into the mixing chamber 1028. Access to the mixing chamber 1028 is permitted by removing the bottle cap 1010. Once the powder is added to the mixing chamber 1028, the user closes the lid 1014 and then applies a pushing force against the resilient portion 1012. The handle 1020 operates as an actuator to apply the force to the resilient portion 1012. A hinge 1021 hingeably connects the handle 1020 to the cap 1010 and includes a curved contacting portion 1034 of a size sufficient to apply a force to the resilient portion 1012. As seen by an arrow 1036, the force applied pushes the mixing chamber 1028 into the bottle 1002 thereby overcoming the seal 1024. As seen by curved arrow 1037, the handle 1020 is hingeably moveable to permit the curved contacting portion 1034 to rotate and apply the force along the arrow 1036. The powder located in the mixing chamber 1028 is then released into the fluid located in the bottle, whereupon the user can then shake the bottle to mix the powder.

As best seen in Fig. 20, the crossed fingers 1030 are connected to the

mixing chamber floor 1032 and extend away therefrom, The ends of the crossed  
finger 1030 are beveled to permit an efficient mixing of the powder. The fingers are  
connected to the chamber floor 1032 and are spaced apart to permit a crossing  
arrangement of the fingers. In the example shown, two crossed fingers 1030 are  
5 illustrated, however, a person skilled in the art will recognize that a plurality of  
fingers may be used depending on the size of the mixing chamber floor 1032 and the  
amount of powder being added to the mixing chamber 1028.

As best seen in Fig. 22 and 23, a re-usable pod 1050 can be used and  
inserted into the shaker. In this embodiment, the user pre-fills the pod 1050 with a  
10 pre-determined amount of powder and then clips the pod 1050 into the mixing  
chamber 1028. The mixing chamber 1028 seals the pod 1050 around the mixing  
chamber floor 1032. The pod 1050 includes a contact portion 1052 to receive  
thereagainst a releasing force (as shown by the arrow 1054) from the hinged handle  
which then disengages the mixing chamber 1028 from the shaker thereby releasing  
15 the powder by gravity into the bottle for shaking. As above, the two crossed fingers  
extend into the mixing chamber. After a mixing operation has taken place, the user  
can disassemble the bottle, remove the pod 1050 and wash it.

Referring now to Fig. 24 and 25, in which a single serve pod 1080 is  
illustrated for use with the shaker bottle. Fig. 24 shows two designs of single use  
20 pod 1081, 1082. In the pod 1081, a knife member 1084 is mounted inside the pod  
1081. A two-layer membrane 1086 is sealed to a bottom edge 1088 of the pod 1081.  
In the pod 1082, a similar design includes a knife 1090 located inside two chambers  
1092, 1094 of the pod 1082.

As best seen in Fig. 25, the pod 1081, by way of example, is located in  
25 the mixing chamber 1028, whereupon the handle 1020 is hingeably moved to engage  
the handle portion 1034 with the pod 1081. The force applied to the pod 1081 causes  
the knives 1084 to puncture the membrane 1086 and release the powder from the  
pod 1081. When viewed from above, as best seen in Fig. 26, the handle 1020 is  
moveable in a smooth manner to crack open the pods located in the shaker. Overall,  
30 the operation of the shaker is aesthetically pleasing and provides an easy mixing

operation without any mess. Moreover, the opening and shaking operation can be carried out using an accurately measured amount of powder.

Referring now to Figs. 26 through 37, illustrate a series of additional alternative embodiments of an apparatus for mixing a powder and a fluid shaker bottle are illustrated. Firstly, an alternative shaker bottle is shown generally at 2000 which can be used using three different scenarios. Firstly, the shaker bottle 2000 can be used without a pod-containing powder; secondly, the shaker bottle 2000 can be operated using a reusable pod containing powder; and thirdly, the shaker bottle 2000 can be used with a single-serve pod.

In all three scenarios, the apparatus 2000 is essentially identical and includes a bottle portion 1002 which is sized and shaped to receive therein an amount of fluid. In the examples used, the fluid is water. Optionally, an exterior sidewall 1001 of the bottle can include an anti-slip surface 1004 to help the user grip the bottle during use. In the example illustrated, the anti-slip surface 1004 includes a plurality of spaced apart, longitudinally disposed ridges. An over mold ring member 1006 is circumferentially connected to an upper portion 1008 of the bottle 1000. A bottle cap 1010 is connected to the over mold ring member 1006 and includes a centrally disposed resilient portion 1012, which is made of a material that permits a pushing force to be applied thereagainst. A bottle lid 1014 and a bottle lid connector 1016 extend over the centrally disposed resilient portion 1012. The bottle lid 1014 is sealingly and removably connected to a mouthpiece 1018. A handle member 1020 is hingeably connected to the cap 1010 and is sized and shaped to be hingeably moved relative to the resilient portion 1012 during a use operation. The mouthpiece 1018 is hingeably towards and away from a seating position, as seen in Fig. 18. When a mixing operation is complete, the user may flip up the mouthpiece 1018 and thus have access to the mixed drink via a fluid passageway which communicates the interior of the bottle with the user's mouth.

Referring specifically to Fig. 28 and Fig. 29, in one example, the user applied a releasing (or pushing) force against the resilient portion 1012 to cause the user applies a releasing force against the resilient portion 1012 with a strength that

is sufficient to slightly disengages the mixing chamber 1028 from the shaker and to release the powder into the bottle such that the crossed fingers 1030, connected to the mixing chamber floor 1032, can be used to agitate and mix the released powder with the fluid.

5 Referring to Fig. 30 and 31, a safety catch 2002 is located adjacent a fluid passageway 2004. The safety catch 2002 includes a catch end 2006 that is slidably downwards and is hinged to permit an orthogonal pushing force to be applied thereagainst. A resilient member 2008 in the form of a spring allows the safety catch 2002 to close and open the bottle cap 1010 when needed.

10 Referring now to Figs. 32, 33 and 34, a circular knife member 2010 is located in the upper portion 1008 of the bottle 2000, The knife member 2010 includes a plurality of cutting surfaces 2012 located on an inner portion of a circumferentially disposed holder 2014. As noted above, in this embodiment, the user applies a pushing force to release the powder. The knife member 2010 presses  
15 against the capsule and tears the lid such that the powder is released and falls into the bottle 2000.

Referring now to Fig. 35, which illustrates a number of powder capsules that have been designed for use with the apparatus. The images at A and B illustrate a capsule 2020 in which two lids snap inside the capsule using a clipping  
20 mechanism 2022. The crossed fingers (also referred to as “feet”) 1030 extending away from the floor 1032A help the user to open the lid, which consists of a flexible capsule and a solid lid. The images at C and D, illustrate a single use capsule. 2024 in which there are two options. The first option involves the use of the knife member 2010 placed inside the capsule whereas the second option involves the use of the  
25 knife located inside the chamber.

Referring now to Figs.36 and 37, an alternative bottle design is shown generally at 3000. The bottle is designed to include a plurality of additional features that enhance the useability of the bottle and to reduce the number of additional bags and containers the user typically carries on or about their person. Each of the  
30 features can be used independent of each other depending on the needs of the user.

A phone holder 3002 provides a secure anchor for a mobile phone. The phone holder 3020 is attached to the bottle 3000 using three clips or a magnet. A number of bags 3022 can be attached to the bottle to hold items such as money, keys, credit cards and the like. The bags 3022 are attached to the bottle using three magnets 3024 located inside each bag to ensure strong but releasable connection to each other. Two magnets 3026 are located to close the bag door. If needed, magnets 2028 are inserted at the base of the bottle to stabilize the bottle when placed on a surface. Two magnets and clips 2030 are used to ensure that the bag holder securely holds both types of bags, if needed.

10

#### Other Embodiments

From the foregoing description, it will be apparent to one of ordinary skill in the art that variations and modifications may be made to the embodiments described herein to adapt it to various usages and conditions.

## CLAIMS

What Is Claimed Is:

1. An apparatus for mixing powder and fluid, the apparatus comprising:  
a bottle sized and shaped to receive therein an amount of fluid, the  
5 bottle having an upper bottle end and a lower bottle end;  
an over mold ring member circumferentially connected to the upper  
bottle end;  
a bottle cap connected to the over mold ring member, the bottle cap  
having a centrally disposed resilient portion;  
10 a bottle lid with a bottle lid connector extending over the centrally  
disposed resilient portion, the bottle lid being sealingly and removably connected to  
a mouthpiece; and  
a handle member connected to the bottle cap, the handle member  
being sized and shaped for holding during a powder release operation.
- 15 2. The apparatus, according to claim 1, includes a mouthpiece moveable  
towards and away from a seating position, the mouthpiece being configured such  
that after a mixing operation is complete, the user flips up the mouthpiece to access  
to the mixed drink via a fluid passageway, the fluid passageway being located to  
communicate the interior of the bottle with a user's mouth.
- 20 3. The apparatus, according to claim 1, in which the bottle includes an  
exterior sidewall having an anti-slip surface.
4. The apparatus, according to claim 1, in which the bottle includes a  
mixing chamber and a mixing chamber floor, a plurality of crossed fingers extending  
from the mixing chamber floor, the mixing chamber being sized and shaped to  
25 receive therein a predetermined amount of a powder, the mixing chamber being  
sealingly connected to an inner portion of the bottle.
5. The apparatus, according to claim 4, in which the powder is a protein  
powder, a powdered drink mix.
6. The apparatus, according to claim 4, in which a re-usable pod is located  
30 in the shaker, the re-useable pod having a pred-determined amount of a powder

therein, the pod having a contact portion to receive thereagainst a releasing force to disengages the mixing chamber from the shaker thereby releasing the powder by gravity into the bottle for shaking.

7. The apparatus, according to claim 1, includes a single serve pod, the  
5 pod having a knife member mounted inside the pod.
8. The apparatus, according to claim 7, in which a two-layer membrane is sealed to a bottom edge of the pod.
9. The apparatus, according to claim 7, in which a knife is located inside two chambers of the pod.
- 10 10. The apparatus, according to claim 1, in which the bottle includes a plurality of magnets connected to the outer sidewall for holding a plurality of bags.
11. A powder dispenser for use with a bottle, comprising:  
a lid body having distal and proximal end portions, and a lid body opening extending between the end portions, the lid body being connectable to a  
15 bottle rim;  
an insert receiving member located adjacent the distal end portion and connected to the lid body opening, the insert receiving member communicating with an interior of the bottle; and  
a pod holding member for snugly holding therein a powder-  
20 containing pod, the pod holding member having a pushing end portion, the pod holding member being cooperable with the insert receiving member, the pod holding member being adapted to cut the pod, so that a pushing force when applied to the pushing end portion pushes the pod holding member into the insert receiving member to cut the pod so as to release the powder therefrom into the bottle.
- 25 12. The dispenser, according to claim 11, in which the insert receiving member includes a downwardly depending sleeve, the sleeve being sized and shaped to permit the pod holding member to slidably insert into the insert receiving member.
- 30 13. The dispenser, according to claim 12, in which the sleeve depends downwardly along a longitudinal bottle axis.

14. The dispenser, according to claim 11, in which the pod holding member is a first cylindrical chamber having a side opening in a chamber sidewall and a lower opening in communication with the interior of the bottle to guide the powder into the bottle when released from the pod.
- 5 15. The dispenser, according to claim 14, in which the pod holding member includes a pushing end portion having a first cutting member connected thereto and depending therefrom.
16. The dispenser, according to claim 15, in which the first cutting member includes one or more blades.
- 10 17. The dispenser, according to claim 12, in which the sleeve is sized to cooperate with the pod holding member.
18. The dispenser, according to claim 11, in which a cylindrical insert cutting member is cooperable with the insert receiving member and is disposed coaxially with the pod holding member.
- 15 19. The dispenser, according to claim 18, in which the cylindrical insert cutting member includes one or more blades.
20. The dispenser, according to claim 11, in which a first cylindrical chamber includes a pushing end portion having a first cutting member connected thereto and depending therefrom; and a cylindrical insert cutting member is  
20 cooperable with the insert receiving member and is disposed coaxially with the pod holding member so that a pushing force when applied to the pushing end portion pushes the first cutting member towards the cylindrical insert cutting member to cut the pod so as to release the powder therefrom into the bottle.
21. The dispenser, according to claim 20, in which the cylindrical insert  
25 cutting member has a diameter smaller than the first cylindrical chamber.
22. The dispenser, according to claim 12, in which the sleeve is angled away from a bottle sidewall.
23. The dispenser, according to claim 22, in which the pod holding  
30 member is a first cylindrical chamber having a side opening in a chamber sidewall and a lower opening in communication with the interior of the bottle to guide the

powder into the bottle when released from the pod.

24. The dispenser, according to claim 23, in which the pod holding member includes a pushing end portion.

25. The dispenser, according to claim 24, in which a cylindrical cutting member is located adjacent the distal end portion and connected to the lid body opening, the cylindrical cutting member being cooperable with the pod holding member and is disposed coaxially therewith so that a pushing force when applied to the pushing end portion pushes the pod holding member towards the cylindrical cutting member to cut the pod so as to release the powder therefrom into the bottle.

10 26. The dispenser, according to claim 25, in which the cylindrical cutting member includes one or more blades.

27. The dispenser, according to claim 24, in which the pod holding member has a diameter smaller than the diameter of the cylindrical cutting member.

15 28. The dispenser, according to claim 11, further includes a hinged closing cap to cover the lid body opening.

29. The dispenser, according to claim 11, in which the pod is generally cylindrical shaped.

20 30. The dispenser, according to claim 11, in which the powder is a protein powder, a milk powder, coffee powder, tea powder, juice powder, vitamin mix, aloe gel, any type of gel, and the like.

31. The dispenser, according to claim 11, in which the bottle contains an amount of a liquid.

32. The dispenser, according to claim 11, in which the pod includes a predetermined amount of the powder.

25 33. The dispenser, according to claim 11, in which the pod is a self-perforating pod.

34. The dispenser, according to claim 11, in which the pod is a compressible bag which ruptures when a force is applied thereto.

30 35. The dispenser, according to claim 11, in which the pod includes an aluminum lid.

36. The dispenser, according to claim 11, in which the lid body includes a resilient bump member for holding the pod in the bottle.

37. The dispenser, according to claim 36, in which the resilient bump member is located to engage a circular knife with the pod so as to release the powder  
5 located therein.

38. The dispenser, according to claim 11, in which the pod includes an integrated clip configured to snappingly engage onto a shaft member, the shaft member being connected to a resilient bump member.

39. The dispenser, according to claim 11, in which the pod includes two or  
10 more clips located to hold the pod in the lid body using an interference fit.

40. A re-useable shaker pod apparatus for use with a bottle having a bottle cap comprising

a mixing chamber having a floor sealingly mounted in the bottle cap;

a plurality of projections connected to the floor and extending away  
15 therefrom, the projections being surrounded by a mixing chamber sidewall, the projections being angled towards each other; and

a resilient member in communication with the mixing chamber and located to contact the projections, the resilient member being located to receive thereagainst an actuating force applied by an actuating handle, the actuating handle  
20 being hingeably connected to the bottle cap, the actuating force being sufficient to push the mixing chamber into the bottle so as to gravitationally release an amount of powder located in the mixing chamber.

41. The apparatus, according to claim 40, in which the mixing chamber includes crossed fingers connected to a mixing chamber floor

25 42. The apparatus, according to claim 40, in which the handle includes a hinge to hingeably connect the handle to the cap, the handle having a curved contacting portion of a size sufficient to apply a force to the resilient portion.

43. The apparatus, according to claim 40, in which the projections include crossed fingers connected to the mixing chamber floor and extending away  
30 therefrom,

44. A re-useable pod for a drink mixer bottle, the pod comprising:  
a pod mixing chamber having a predetermined amount of a powder located therein, the chamber being engageable with an upper portion of the drink mixer bottle, the chamber being sealed against the upper portion of the bottle
- 5 a contact portion located on a pod surface away from the mixing chamber, the contact portion being located to receive thereagainst a releasing force; and
- 10 a mixing floor having a plurality of projections extending away therefrom, the mixing floor being released when a hingeably actuating handle applies the releasing force against the contact portion to move the mixing floor into the bottle thereby gravitationally releasing the powder into the bottle.

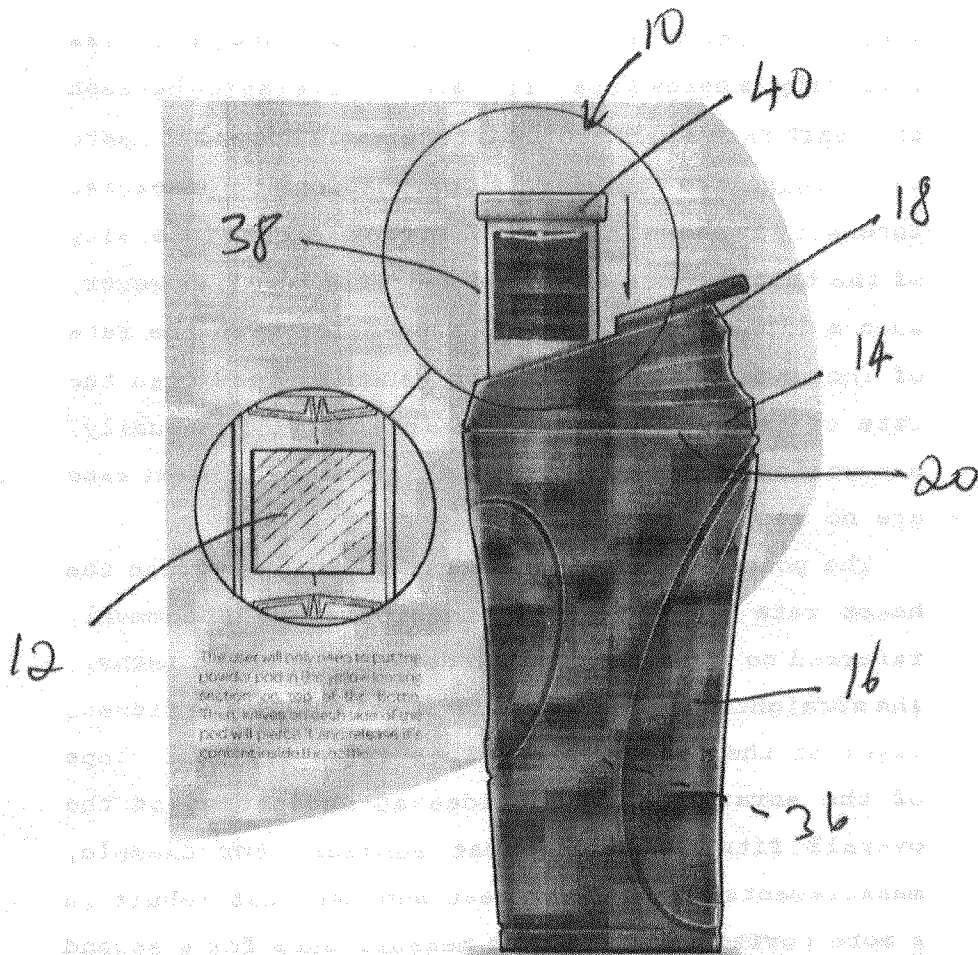

FIG. 1

### How it work

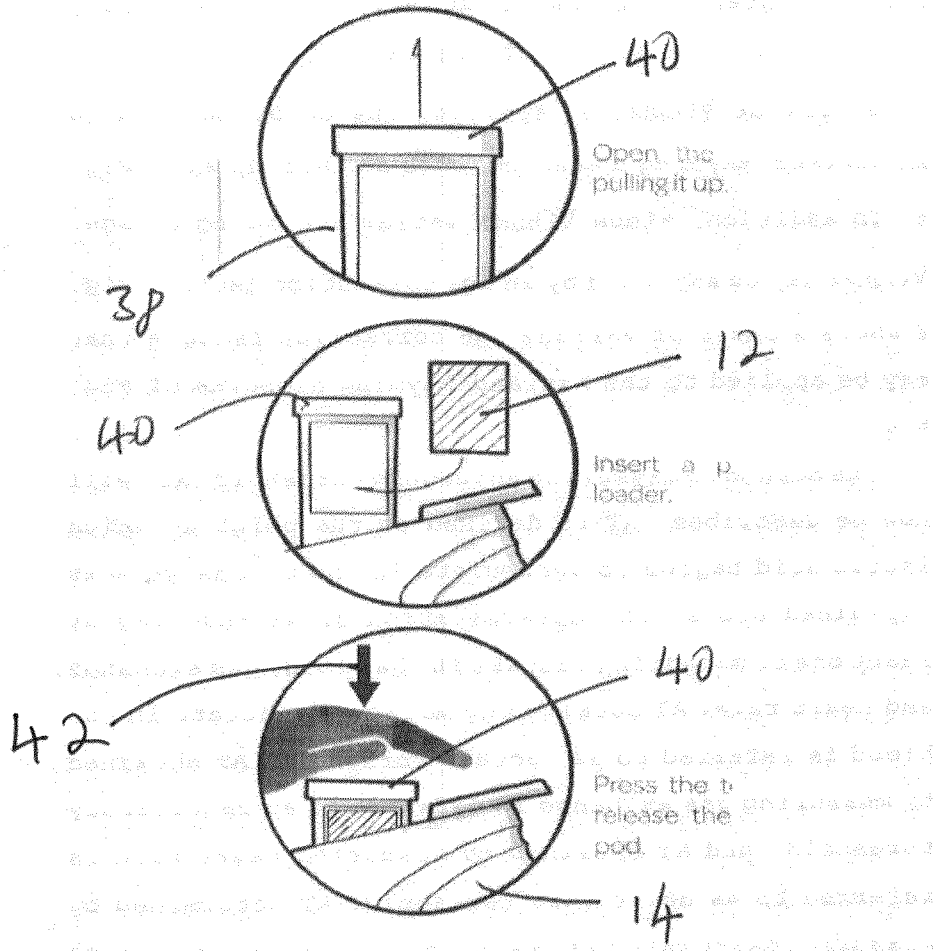

FIG. 2

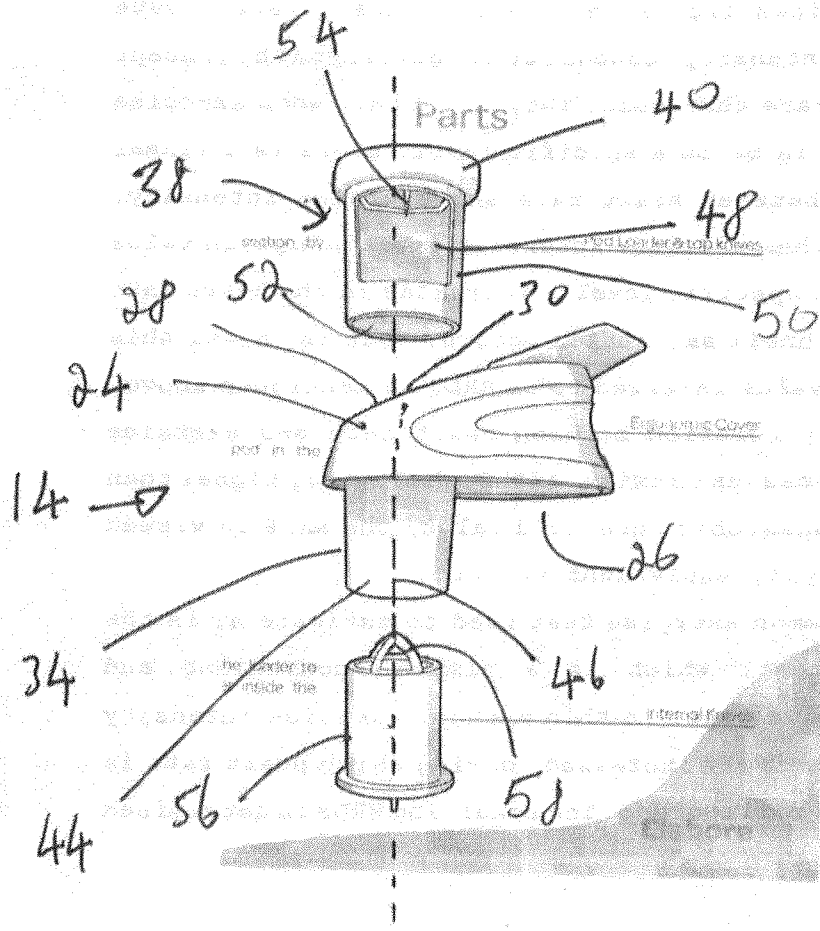
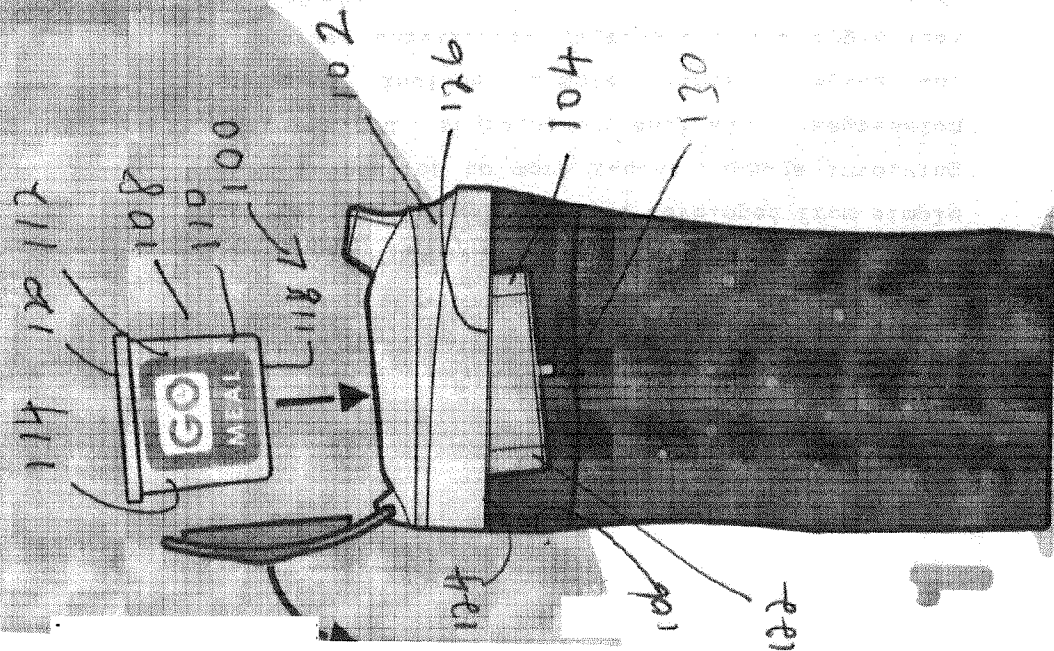

FIG. 3

# Accret

FIG. 4



Open the loading section by opening the cap.

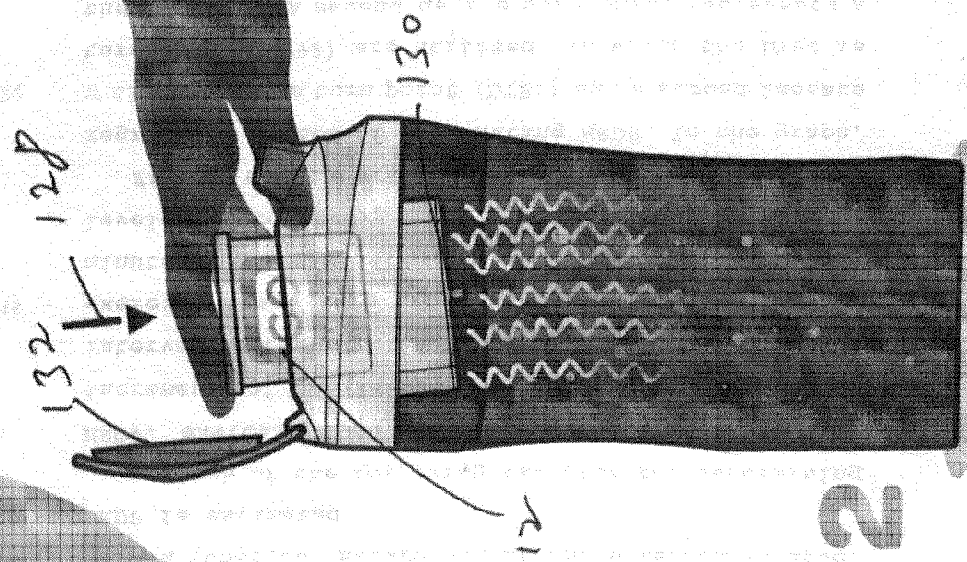

Insert the pod in the loading section and push the top with your hand. The knives in the cover will leak the pod's content.

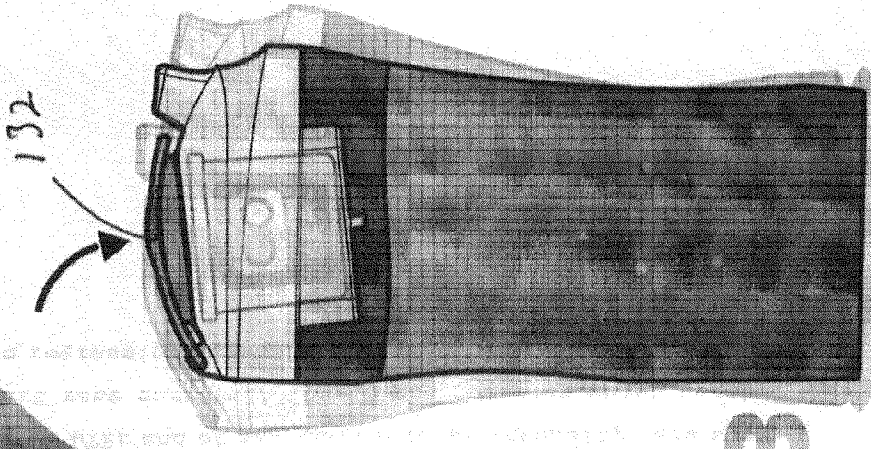

Close the cap and shake the bottle to mix the powder and water.

1

2

3

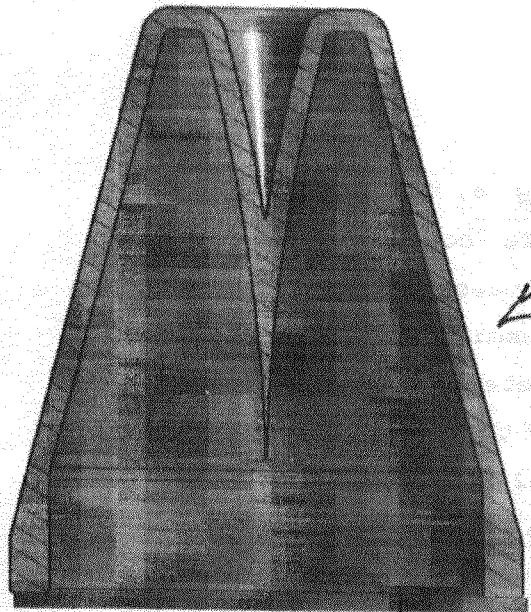

FIG. 5A

202

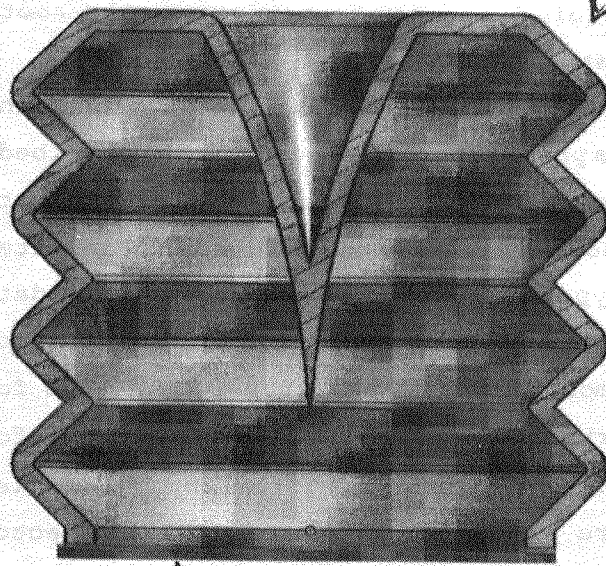

FIG. 5B

202

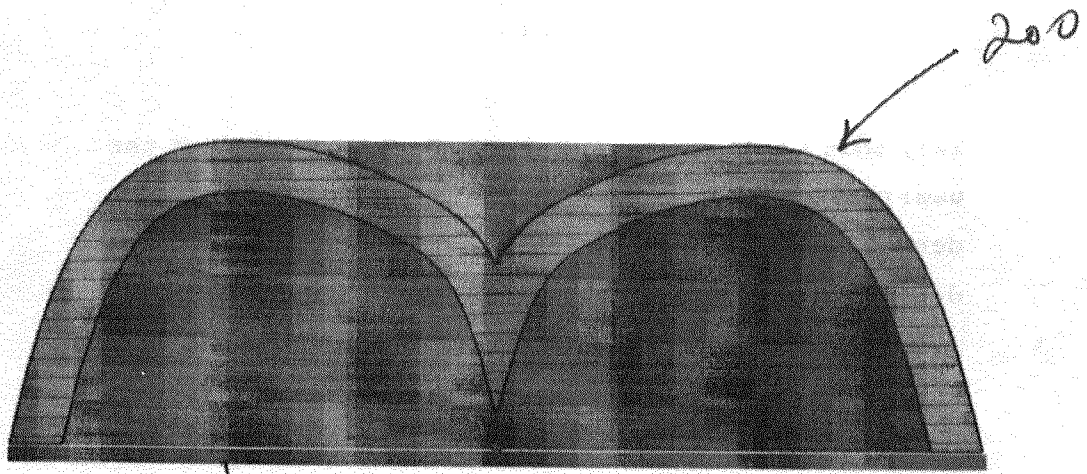

FIG. 5C

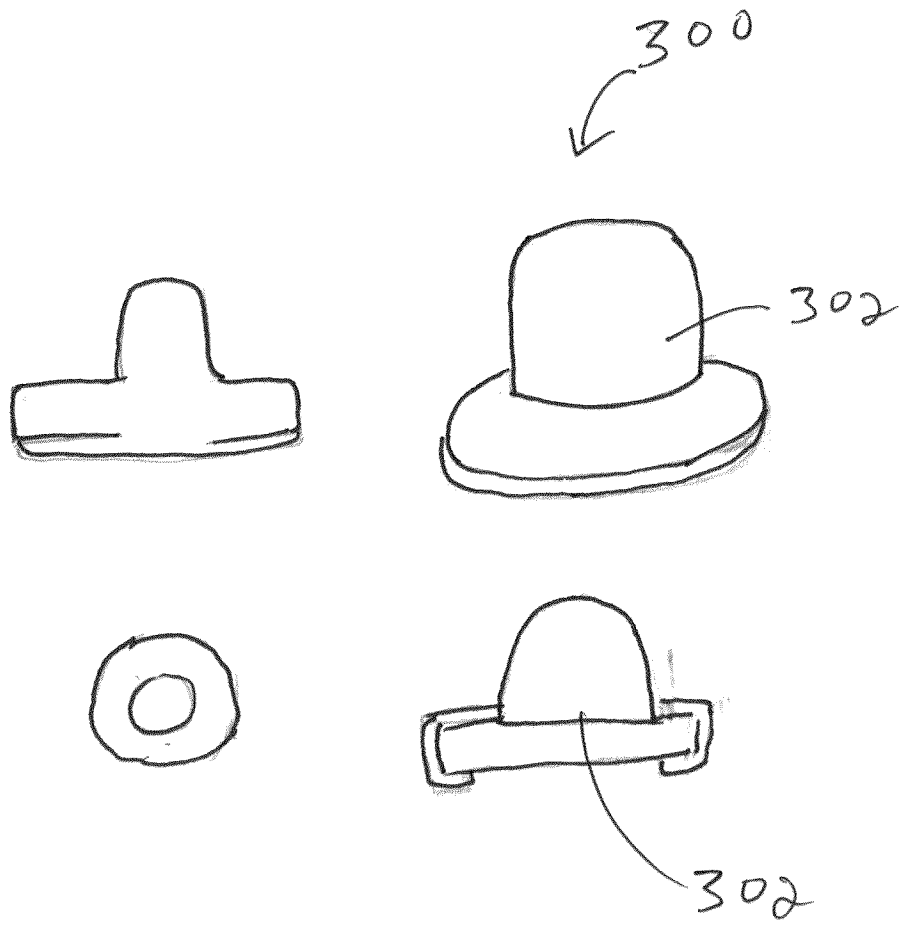

FIG. 6

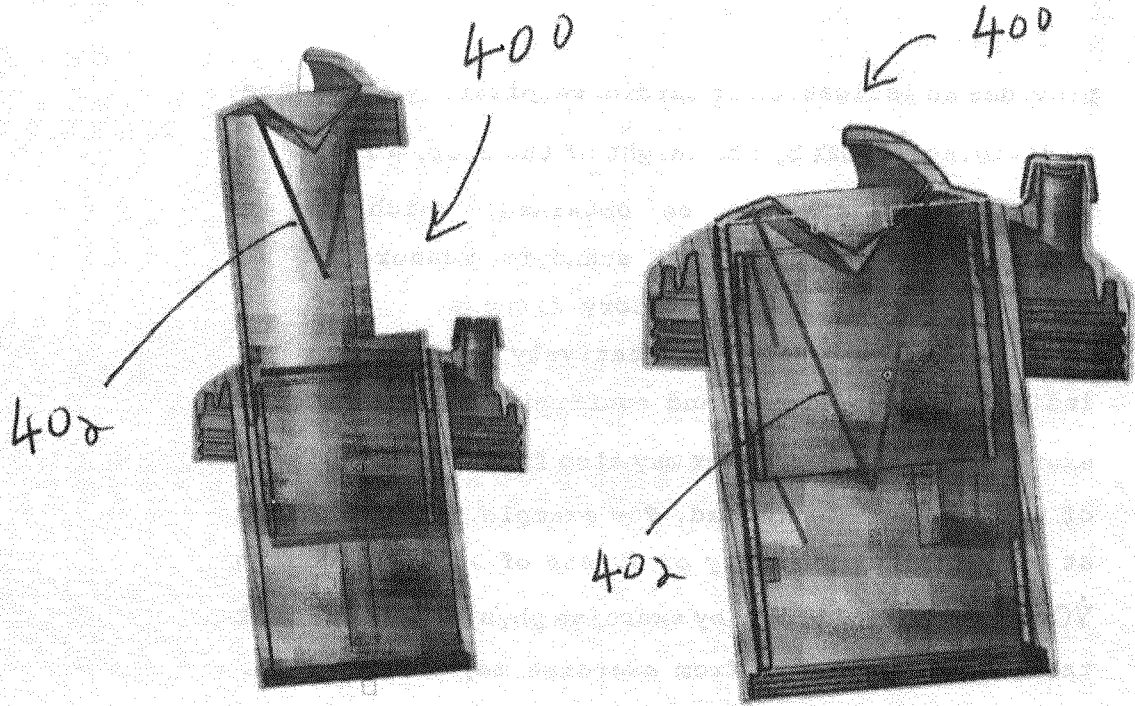

FIG. 7A

FIG. 7B

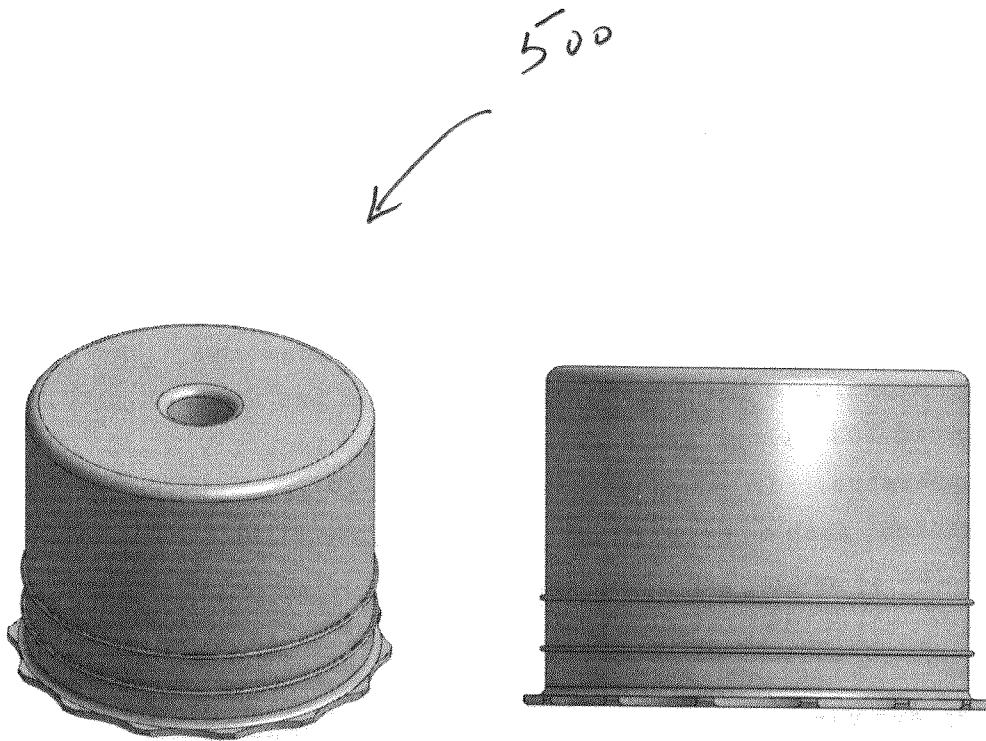

FIG. 8

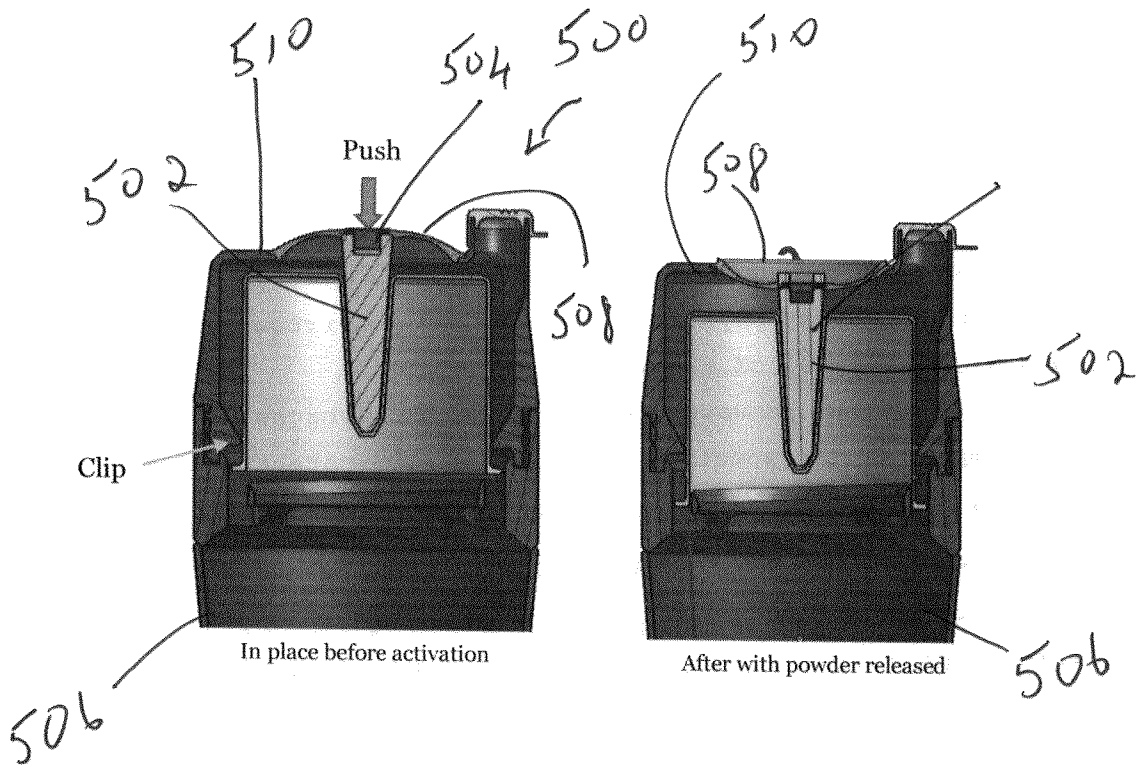

FIG. 9A

FIG. 9B

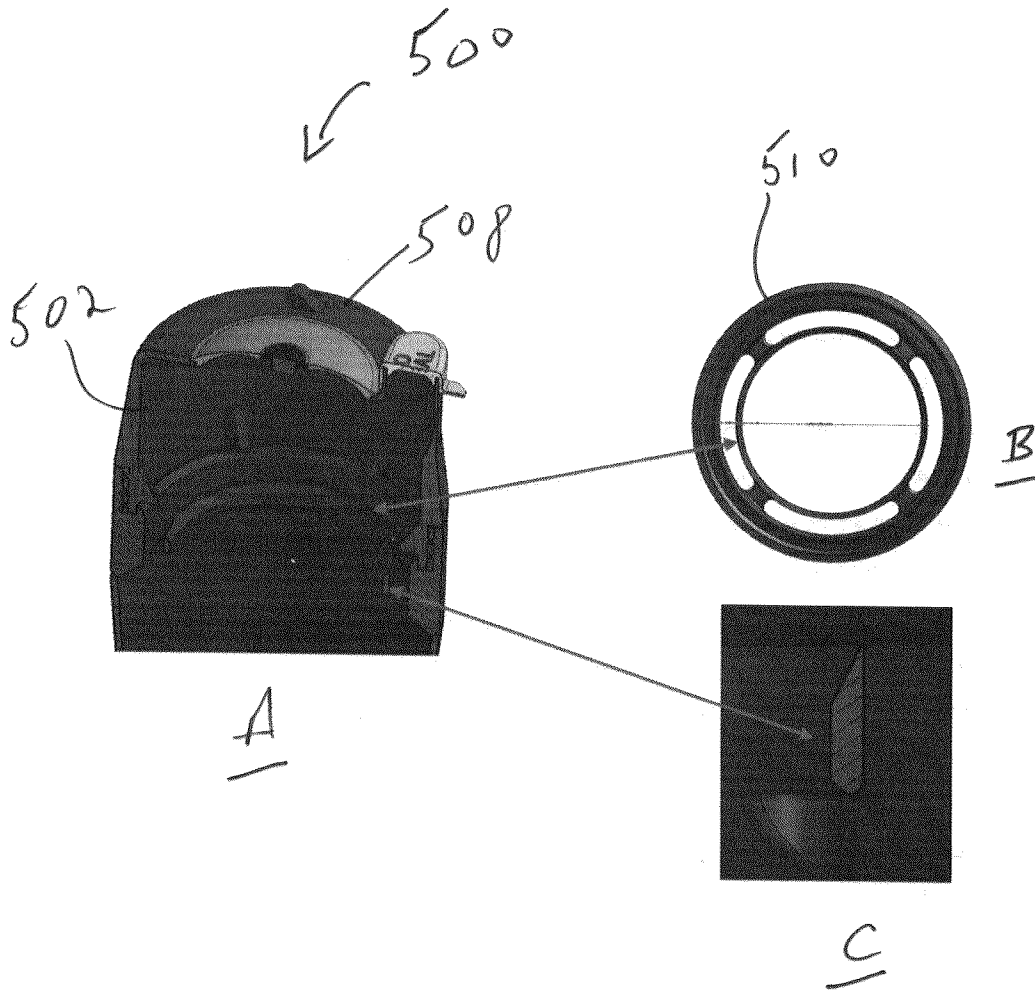

FIG. 10

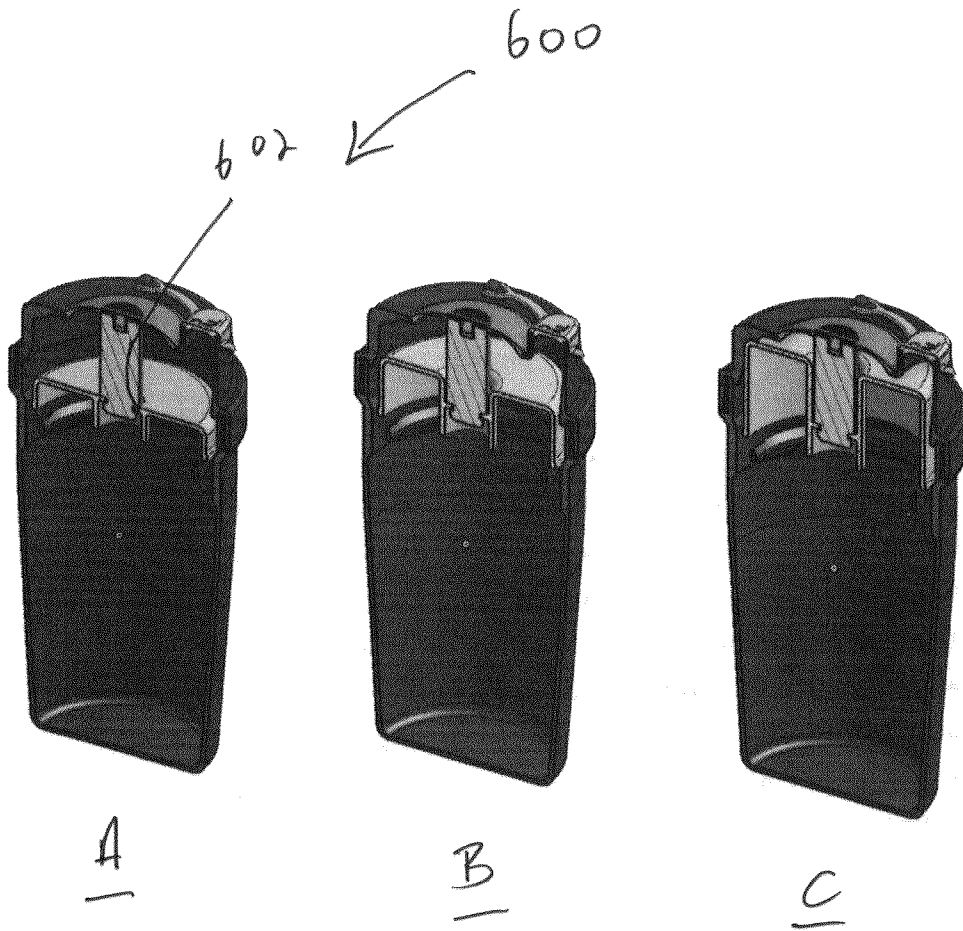

FIG. 11

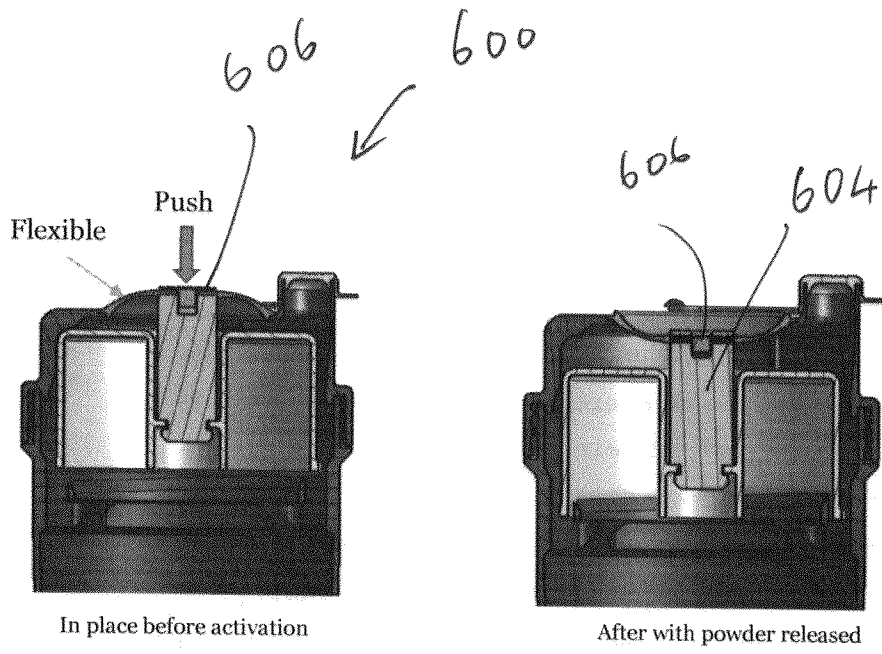

FIG. 12A

FIG. 12B

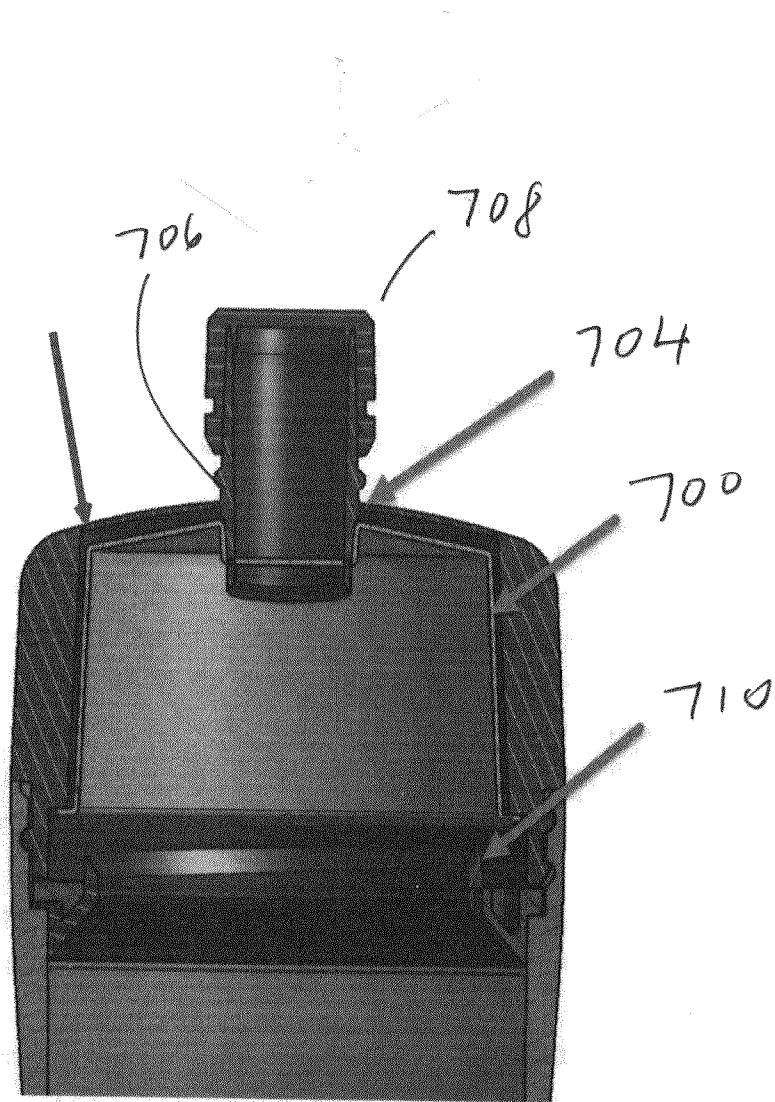

FIG. 13

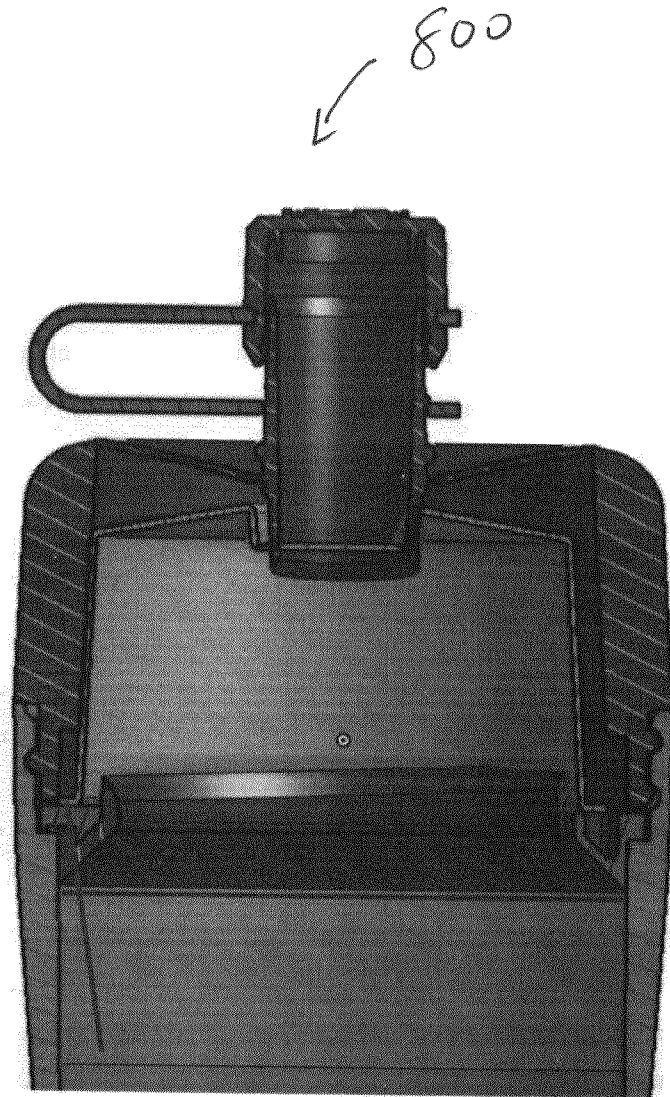

FIG. 14

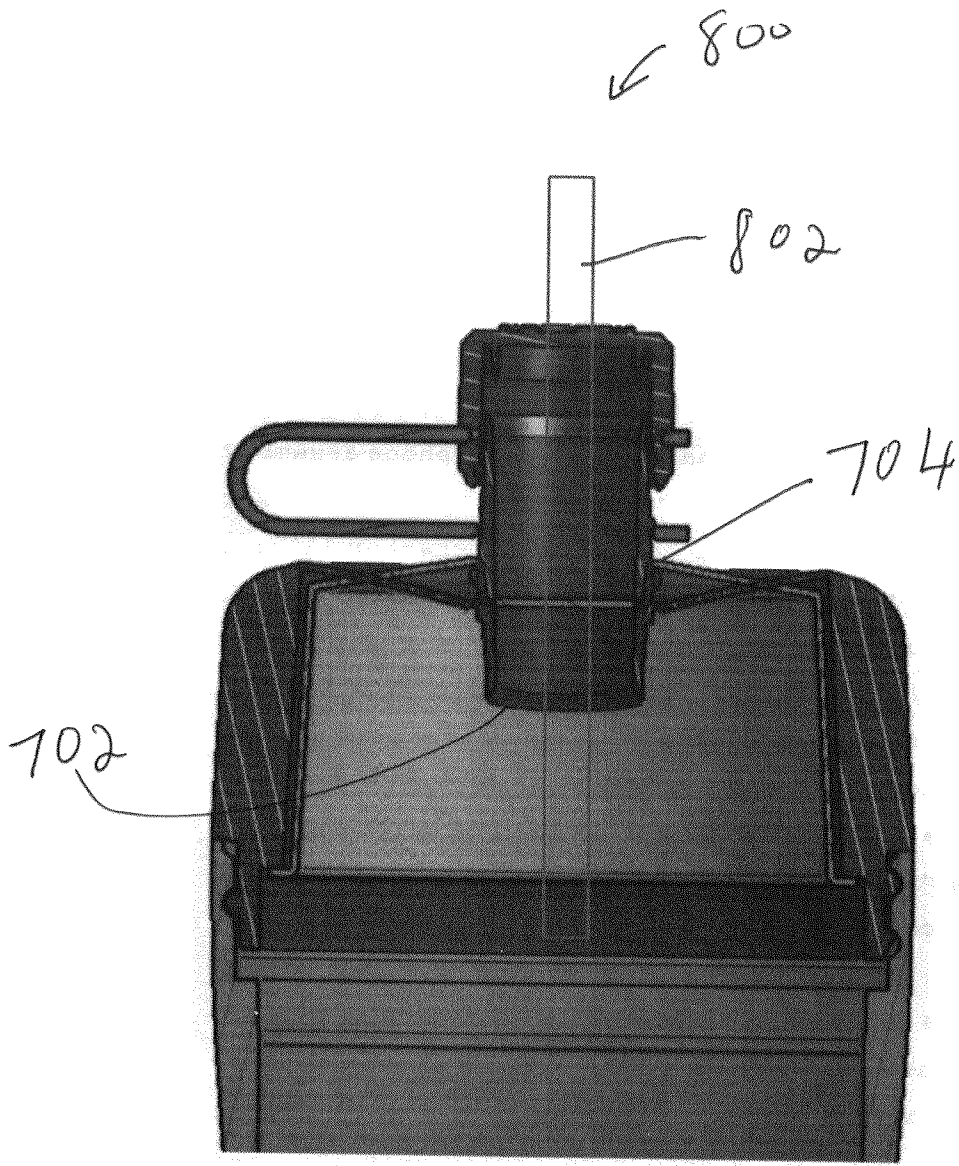

FIG. 15

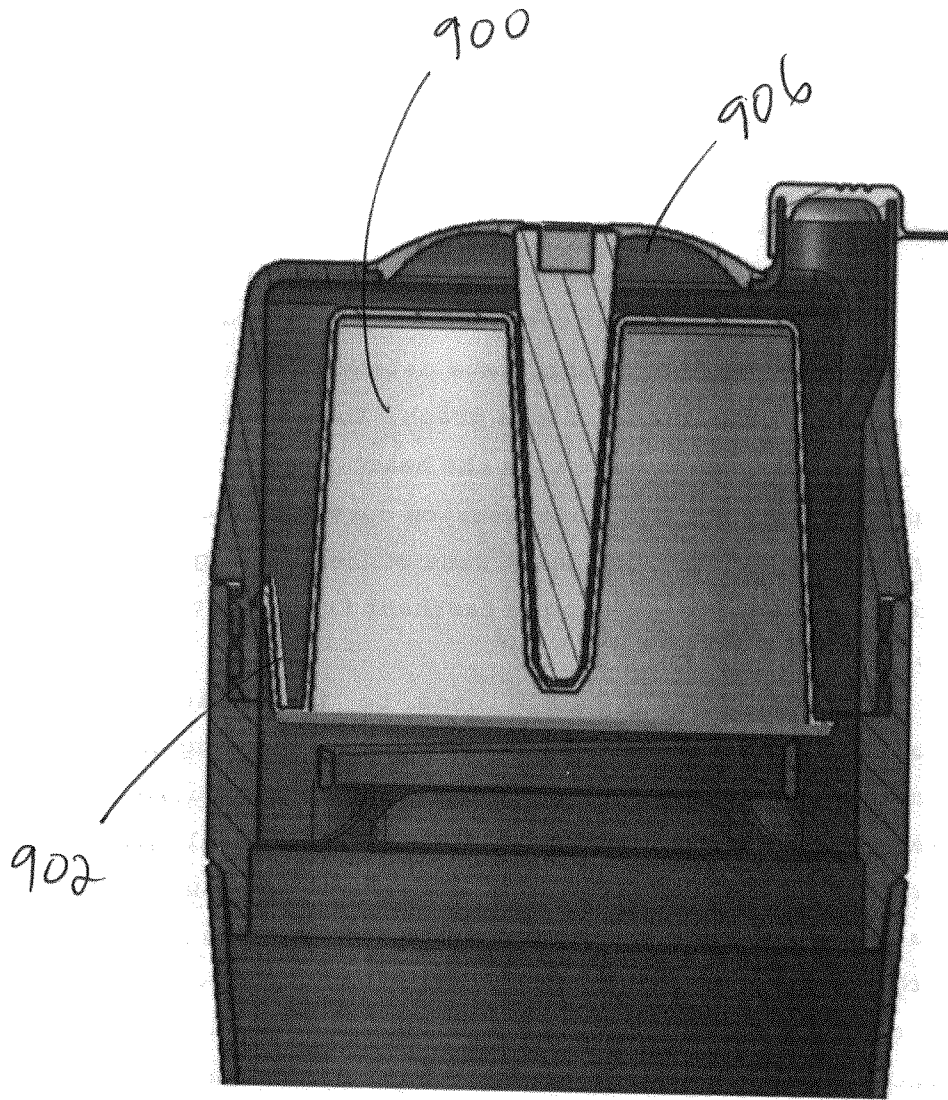

FIG. 16

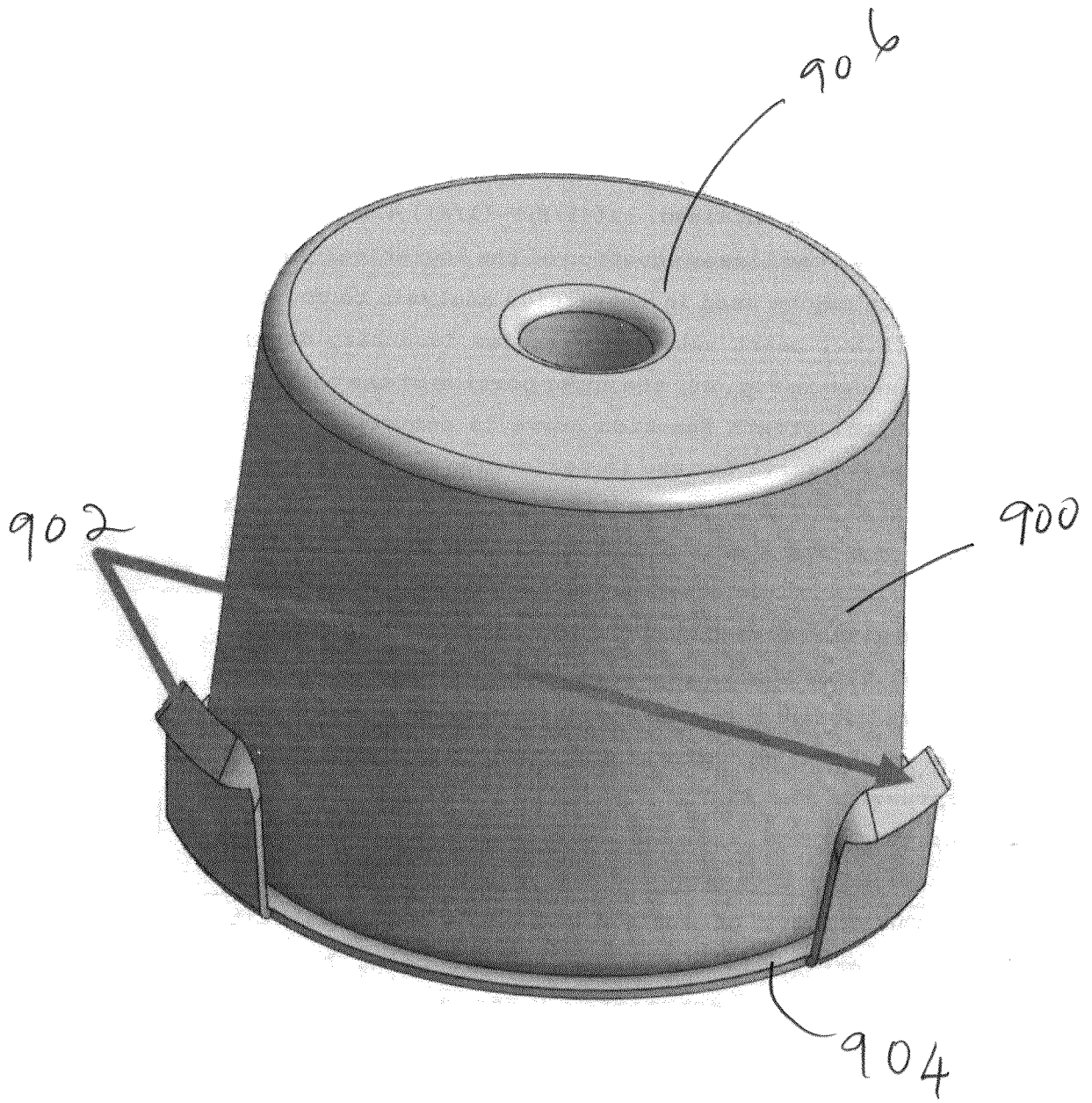

FIG. 17

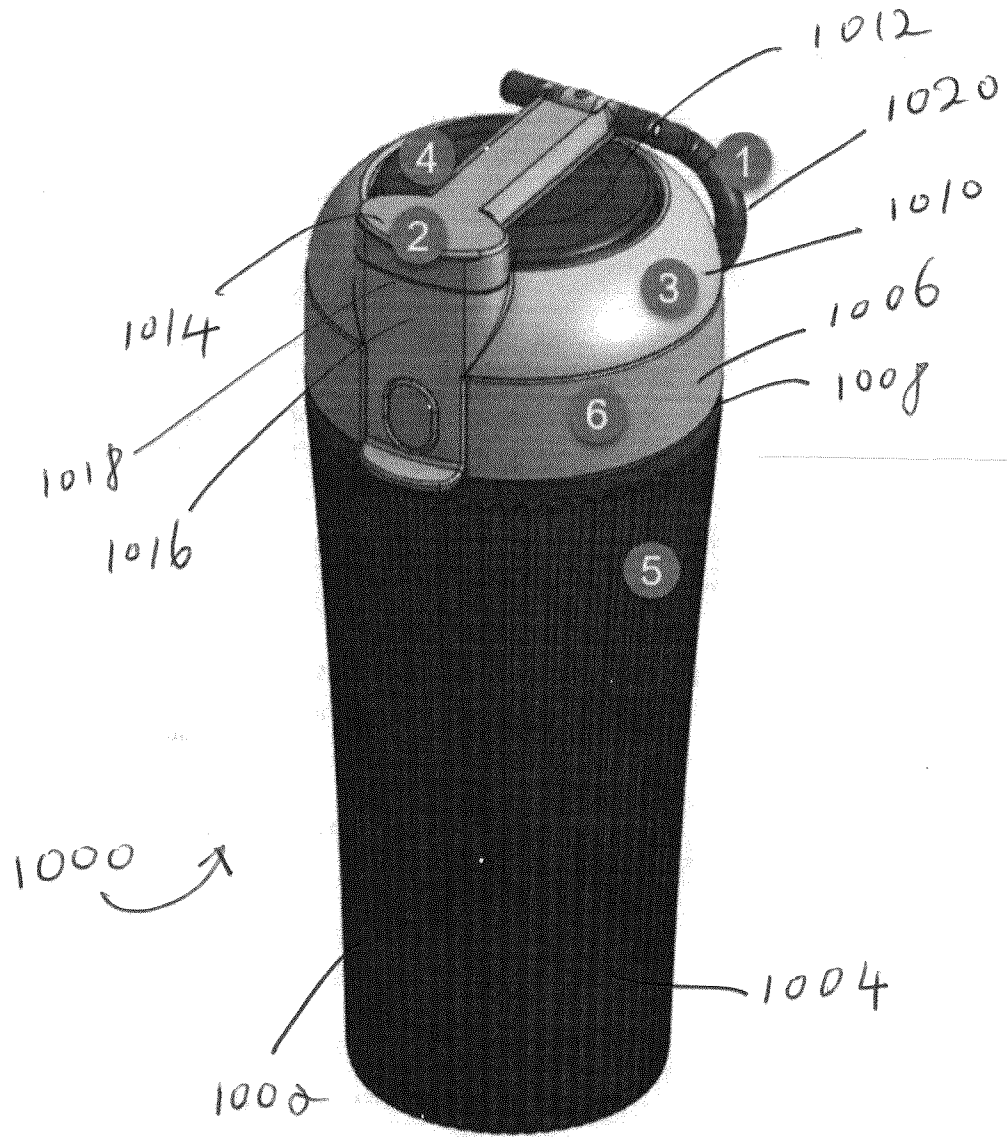

FIG. 18

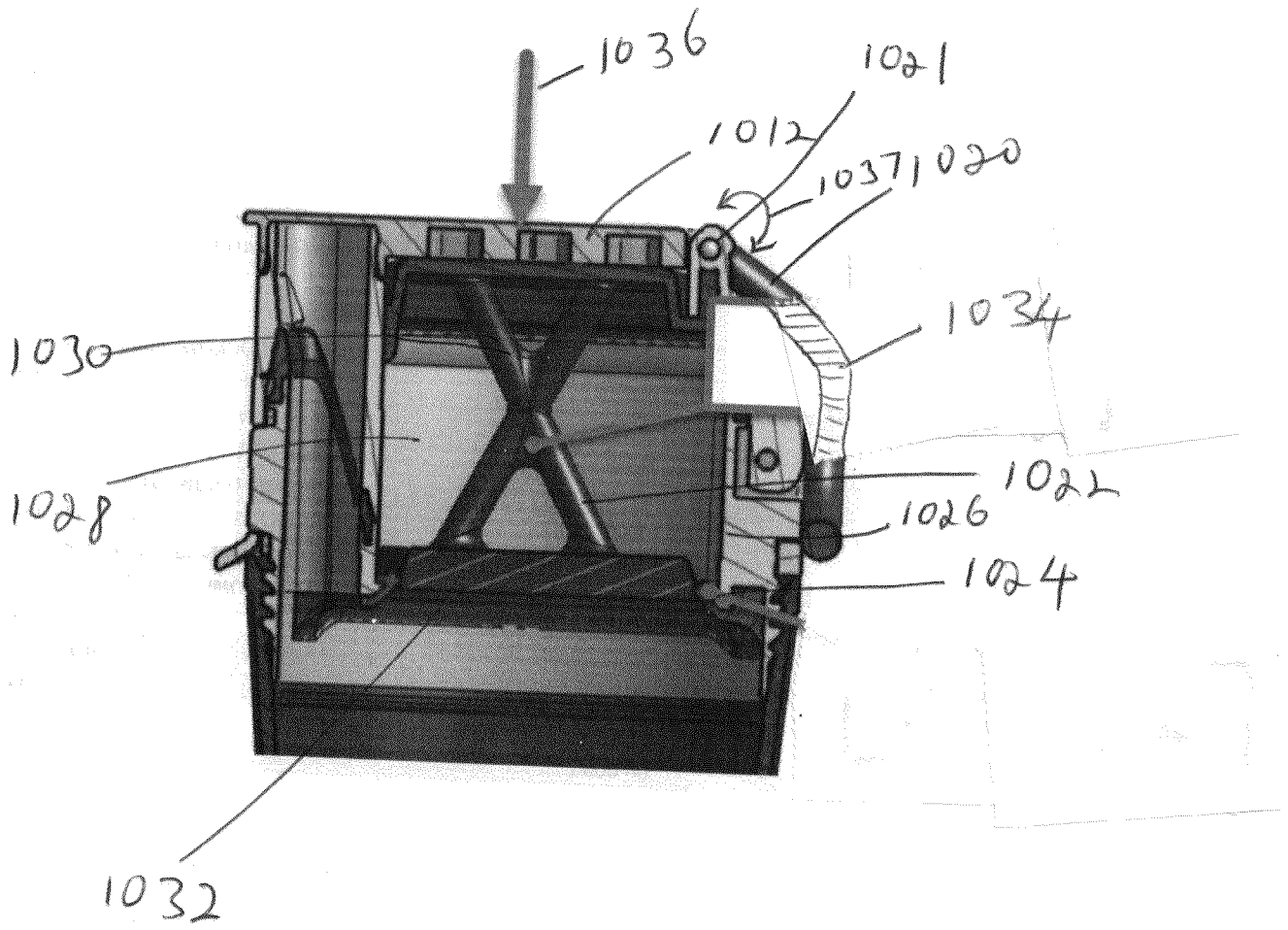

FIG. 19

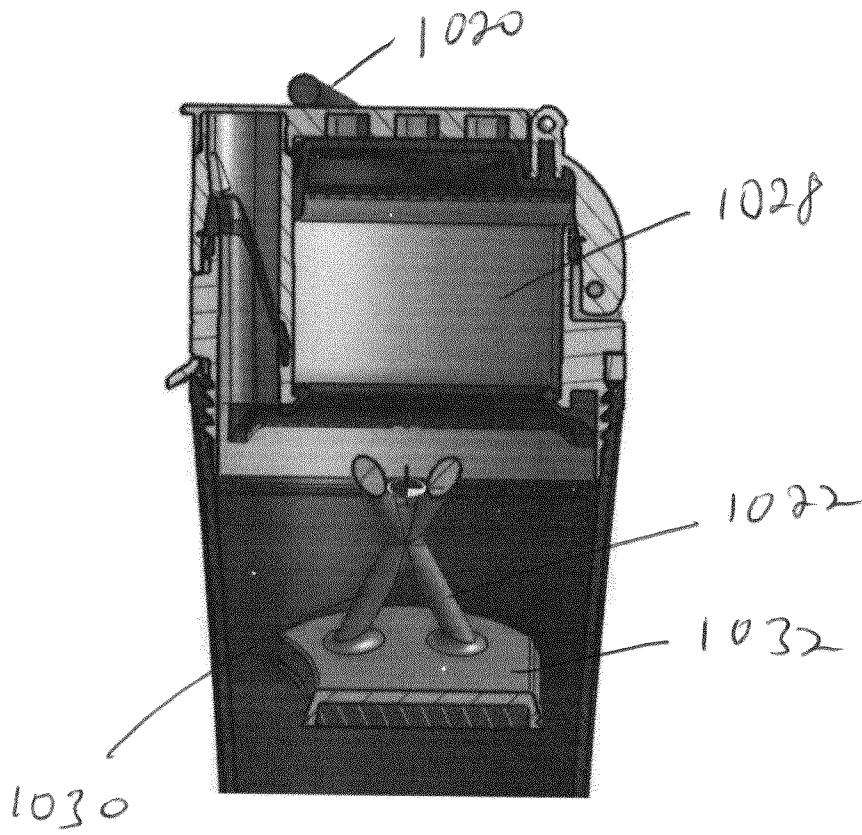

FIG. 20

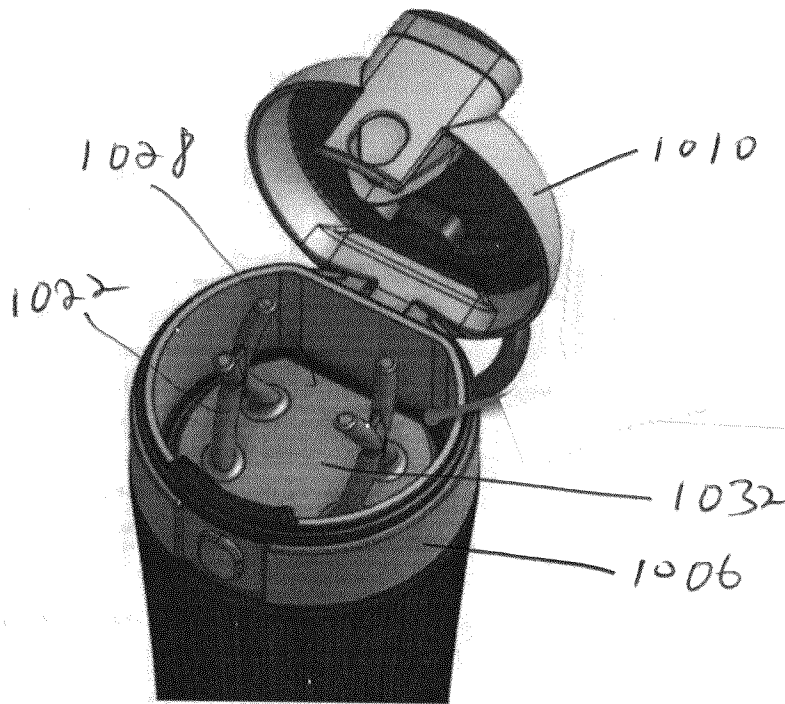

FIG. 21

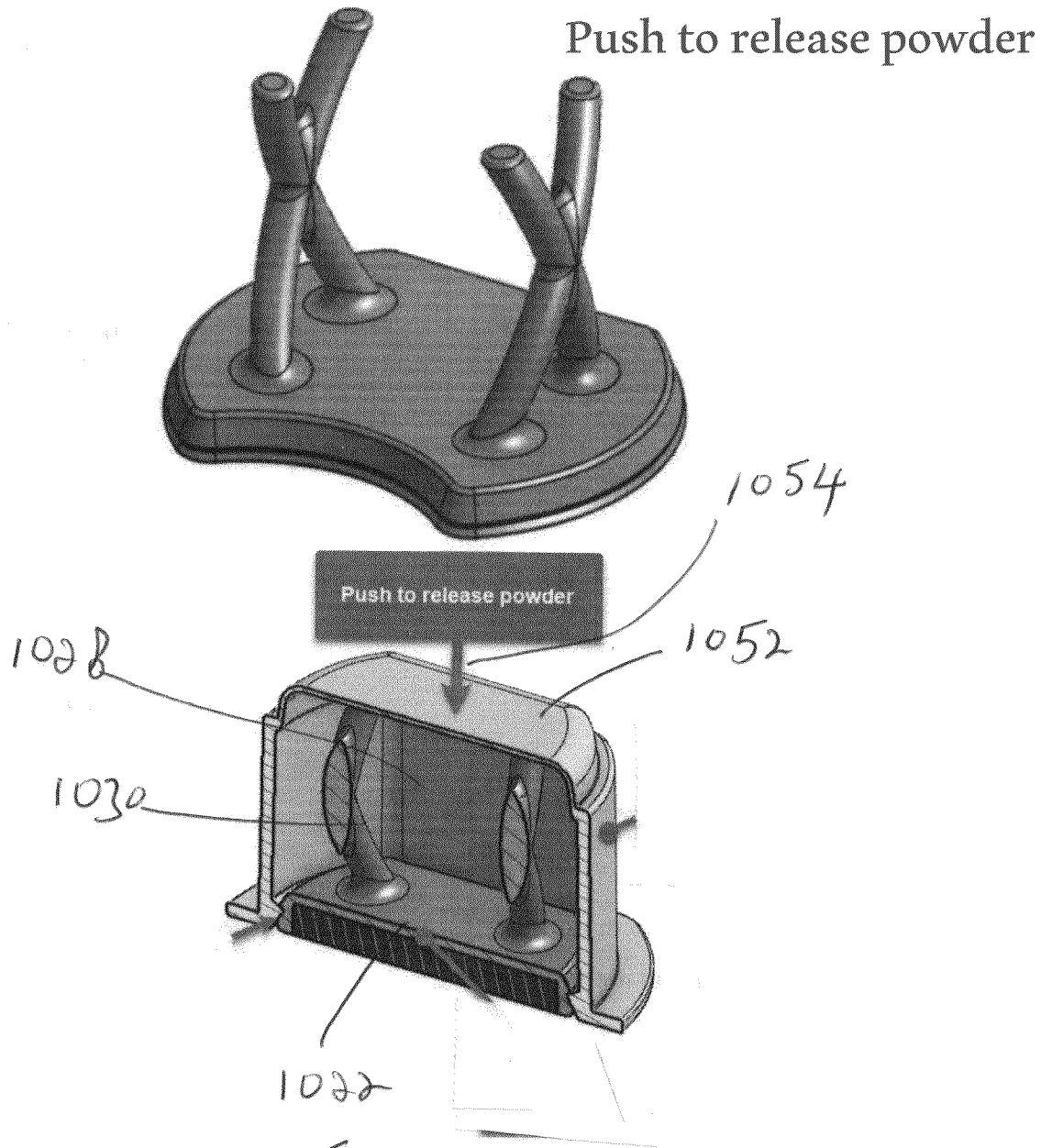

FIG. 22

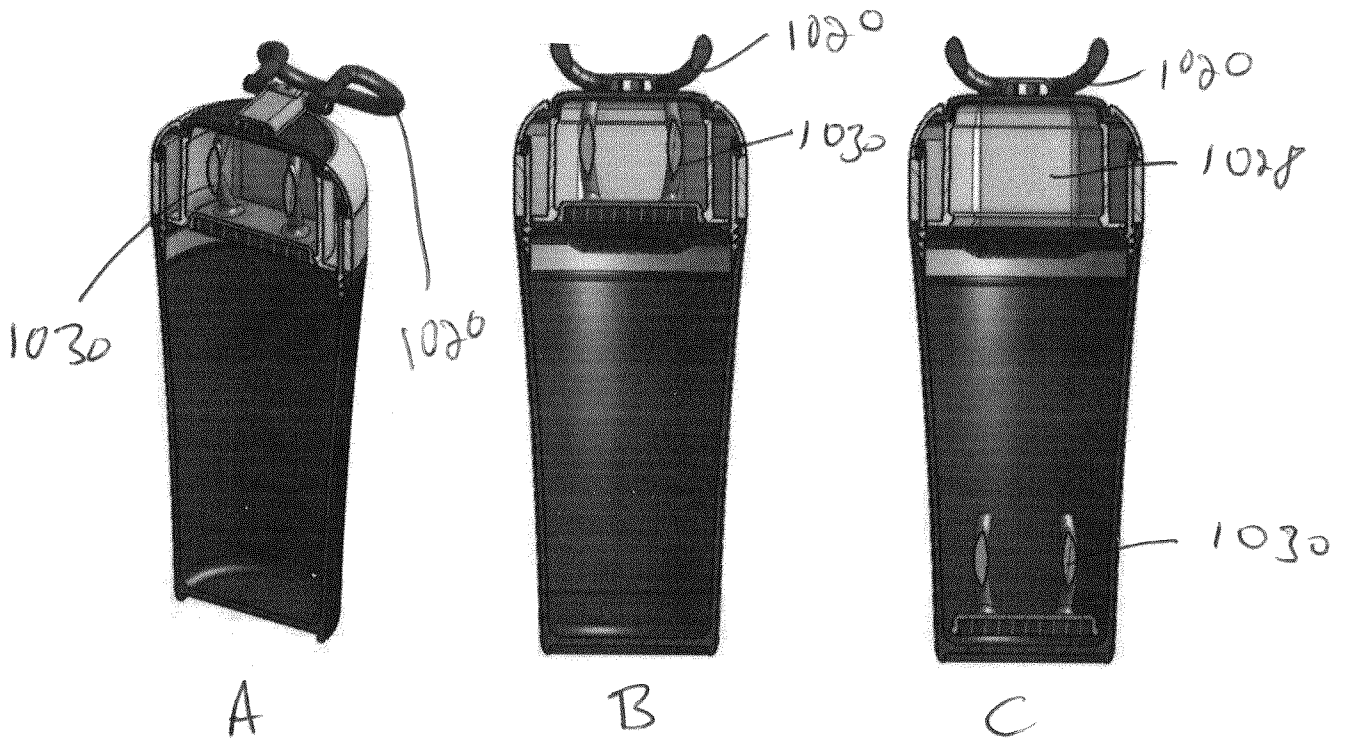

FIG. 23

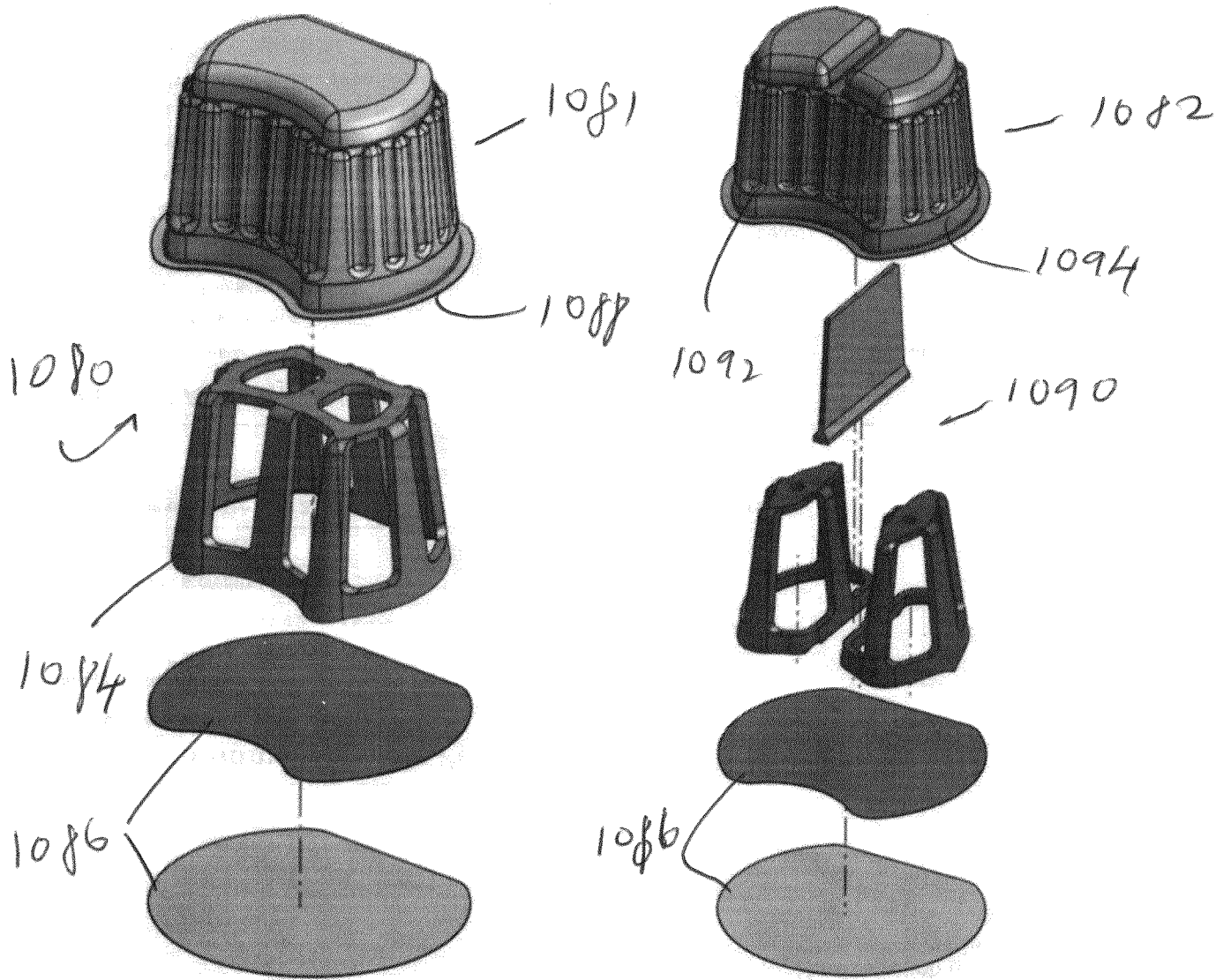

FIG. 24

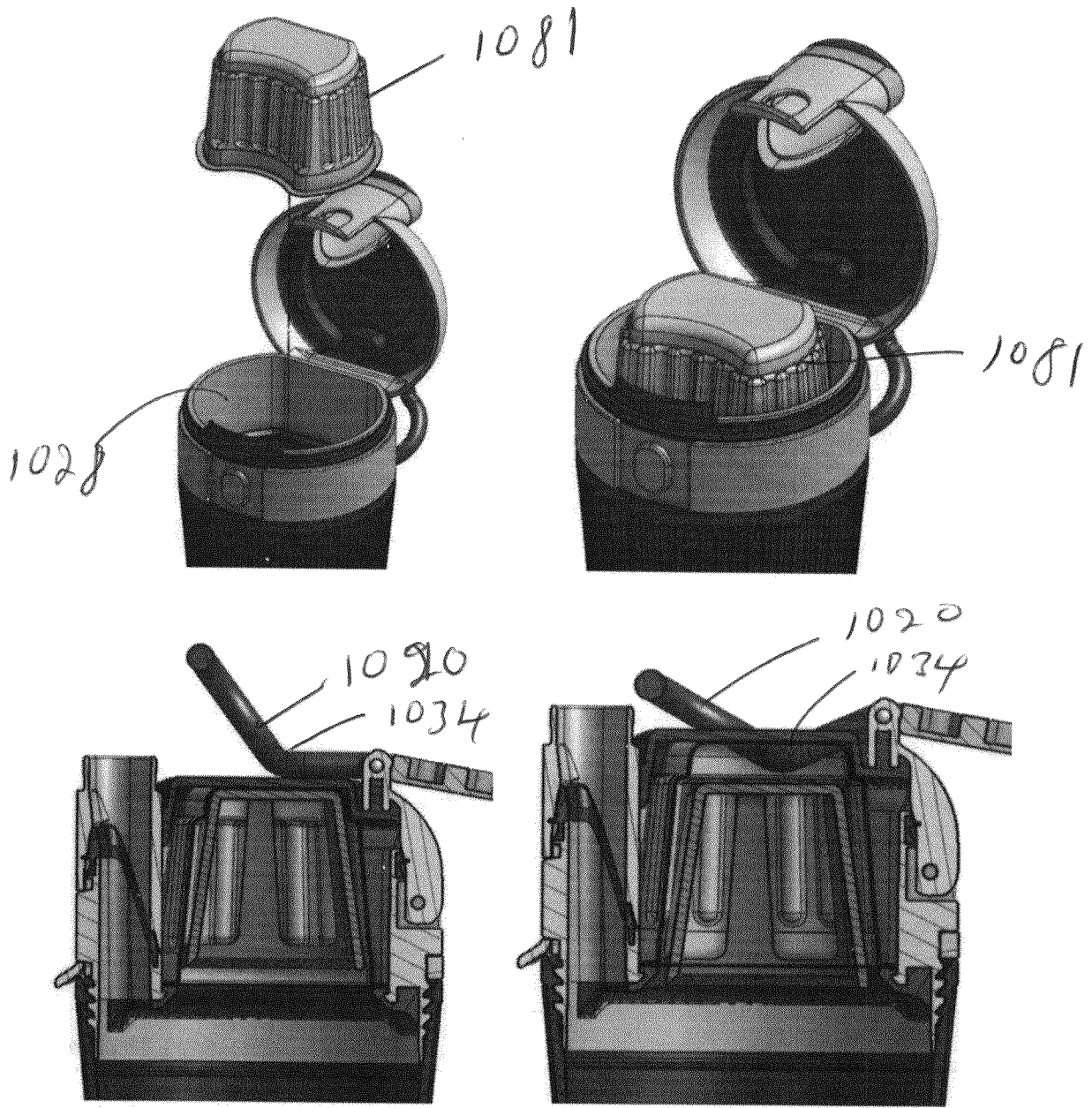

FIG. 25

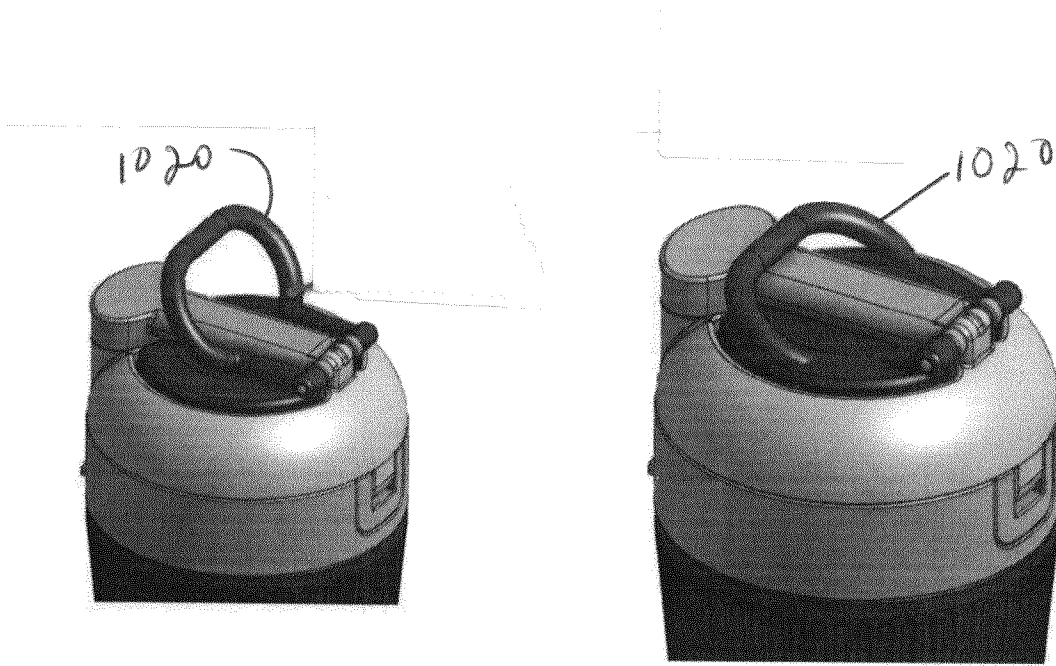

FIG. 26

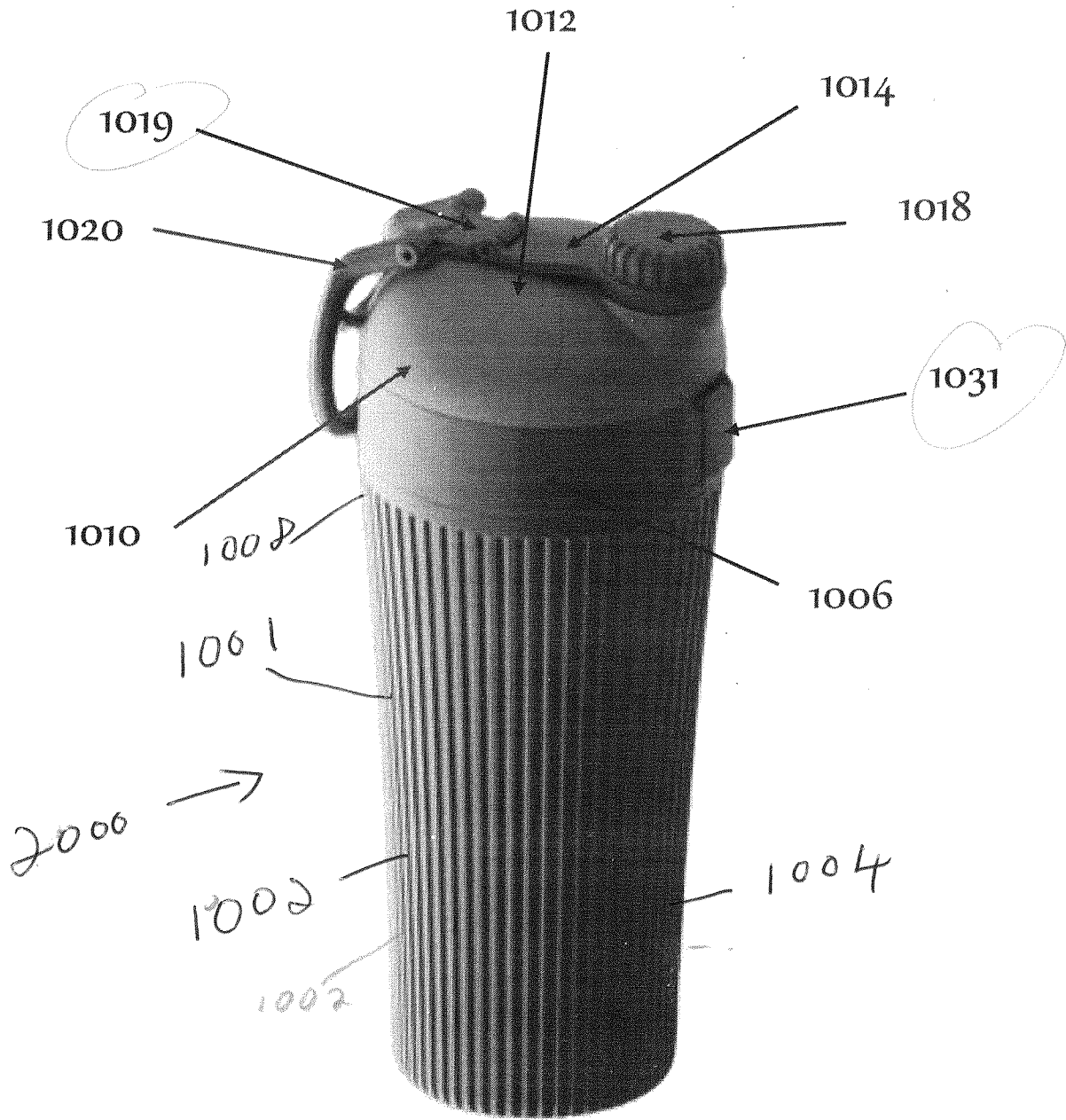

FIG. 27

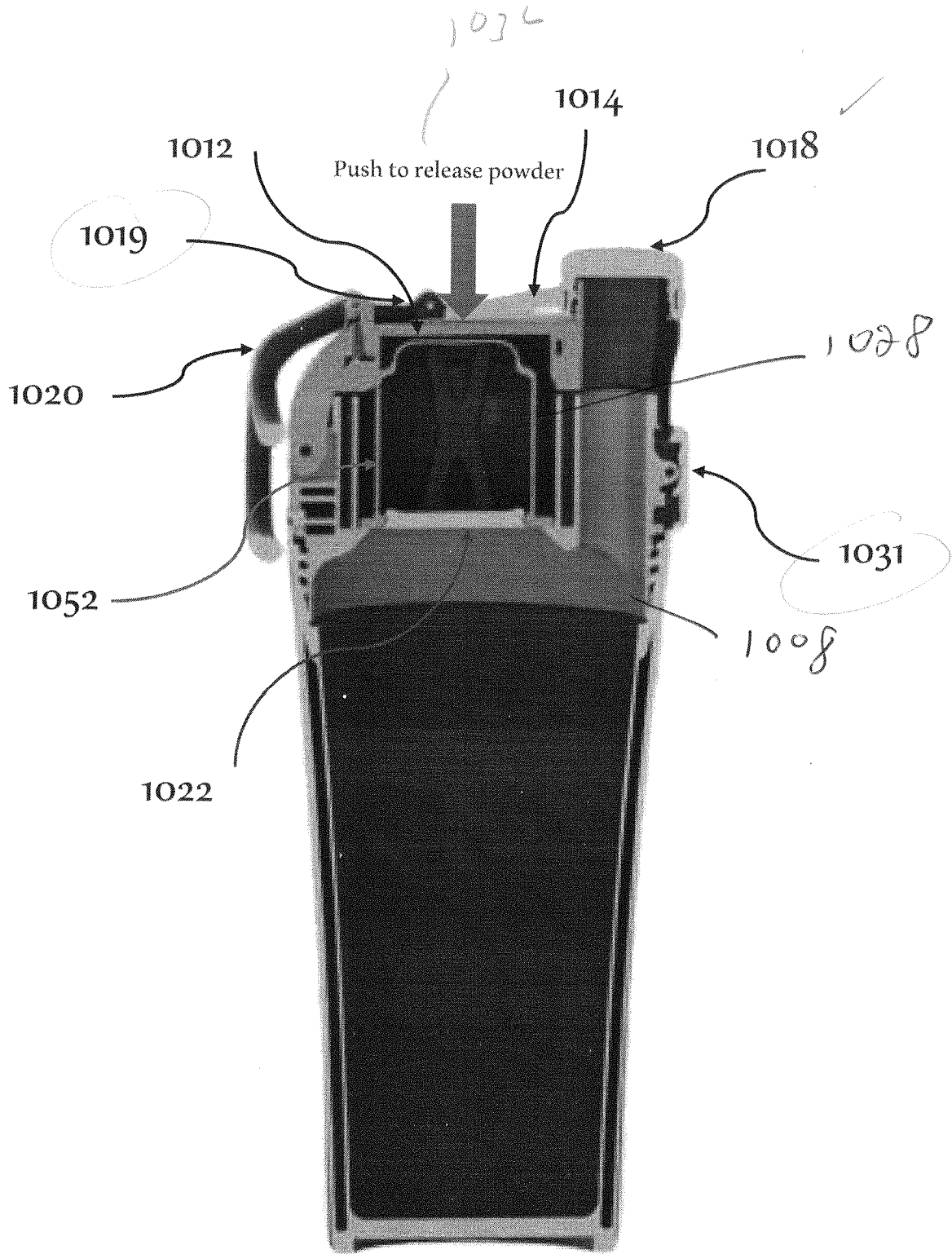

FIG. 28

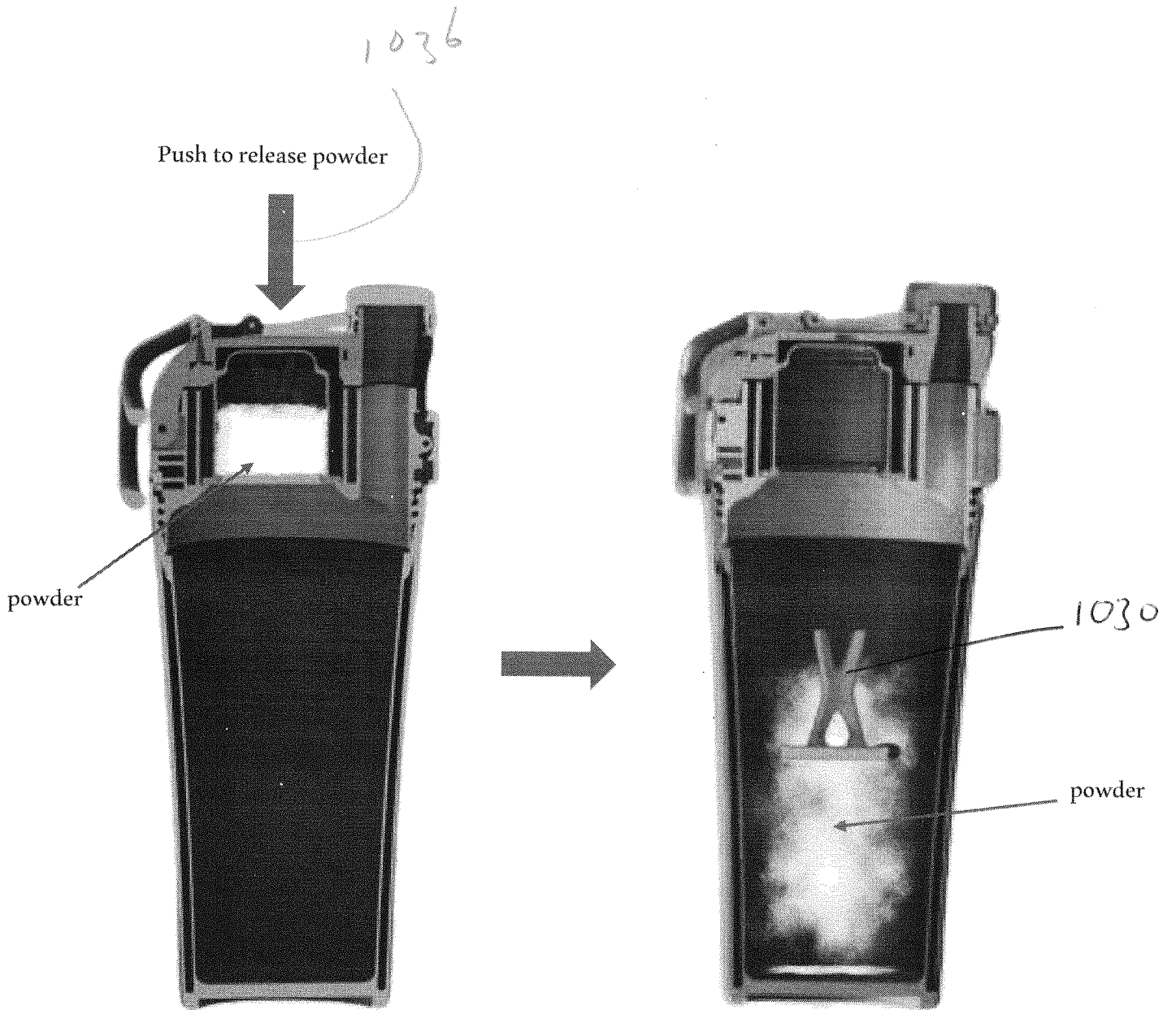

FIG. 29

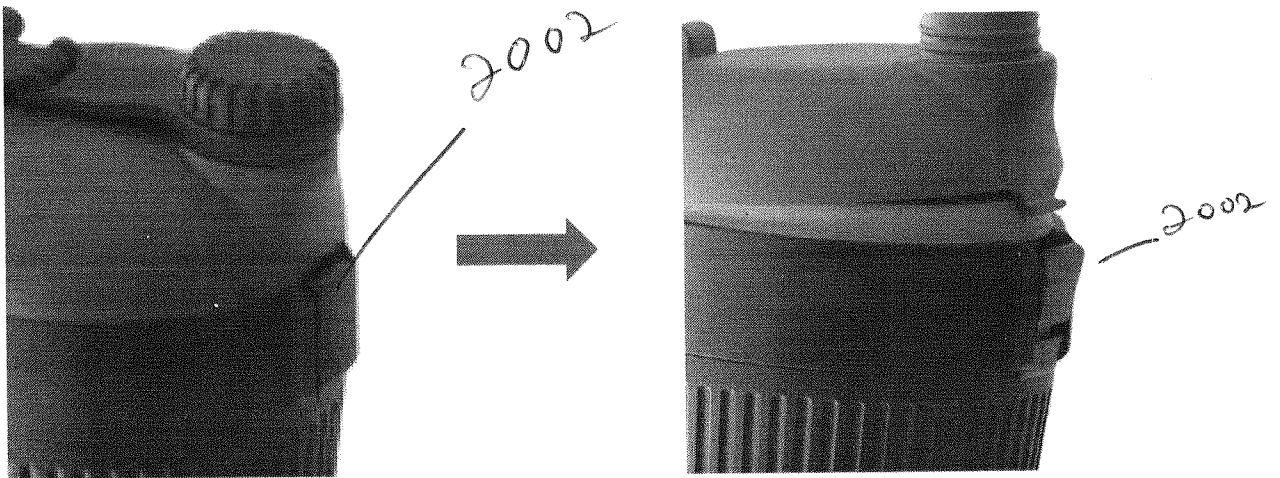

FIG. 21

FIG. 30

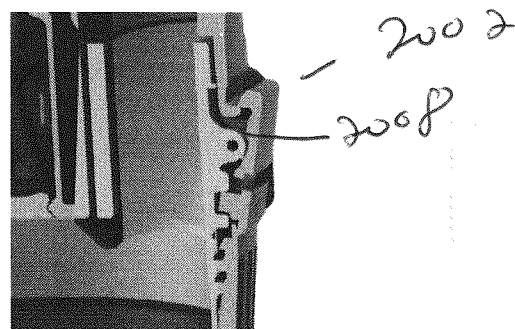
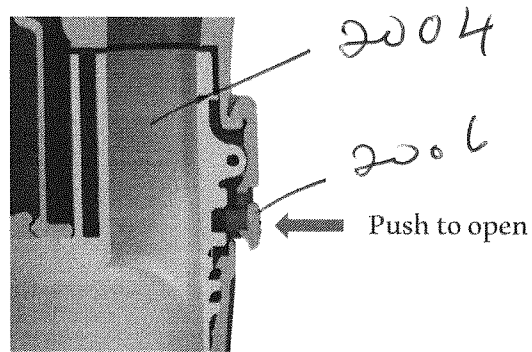
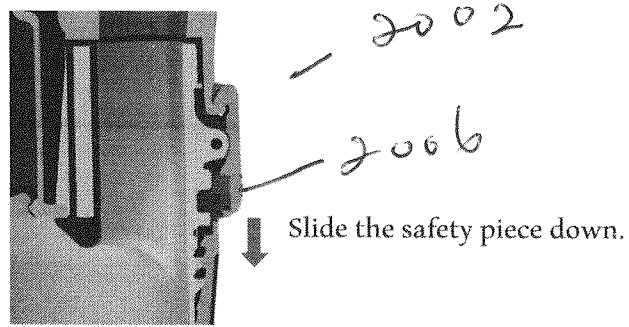

FIG. 31

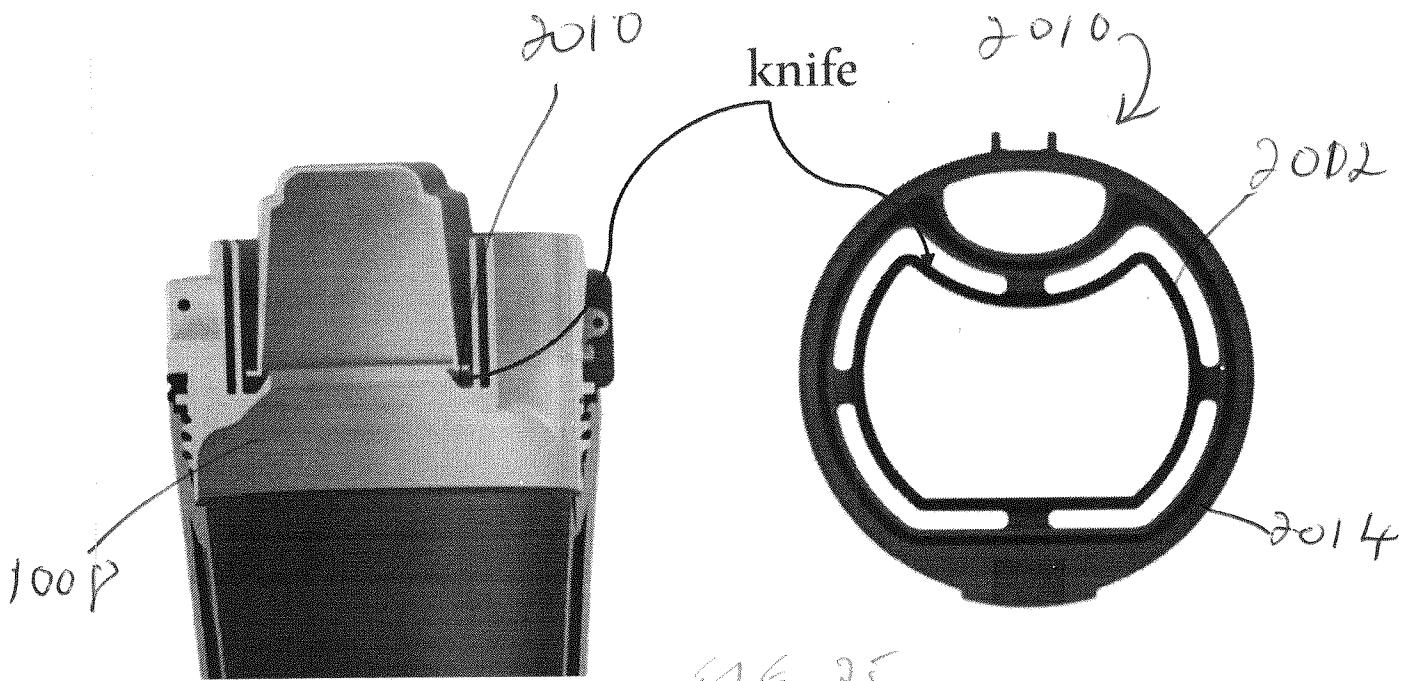

FIG. 25

FIG. 32

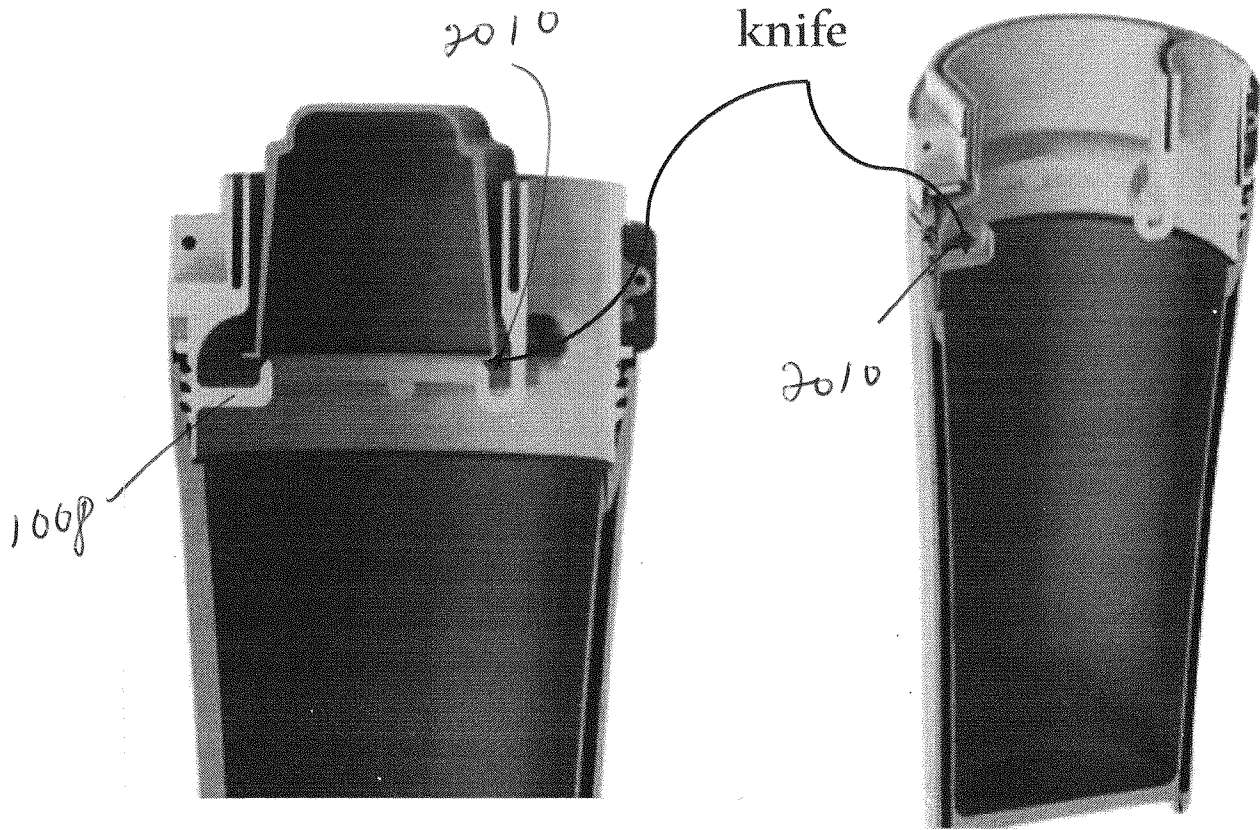
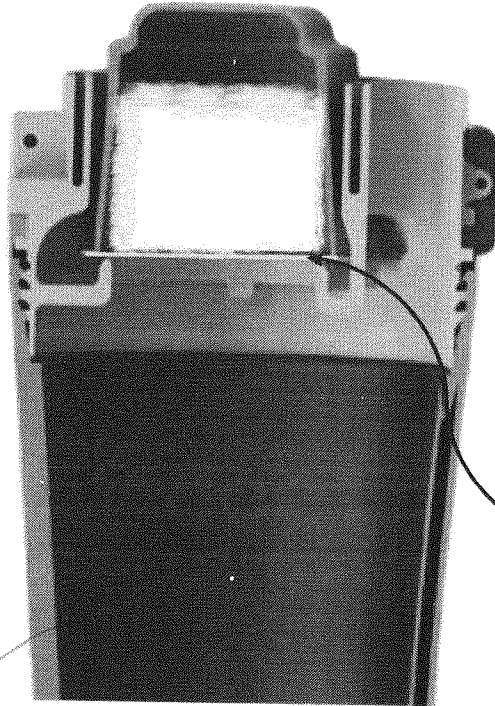

FIG. 33

34/37

Push to release powder



2010

2000

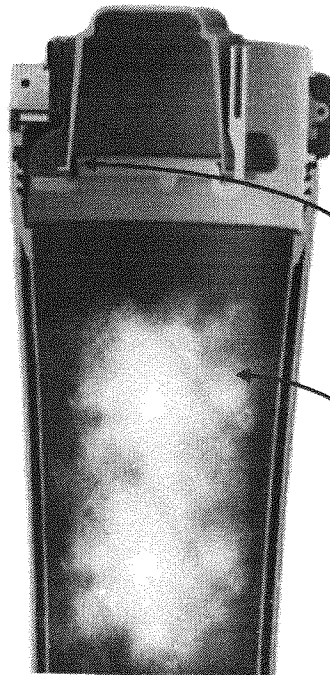

2010

FIG. 3.4

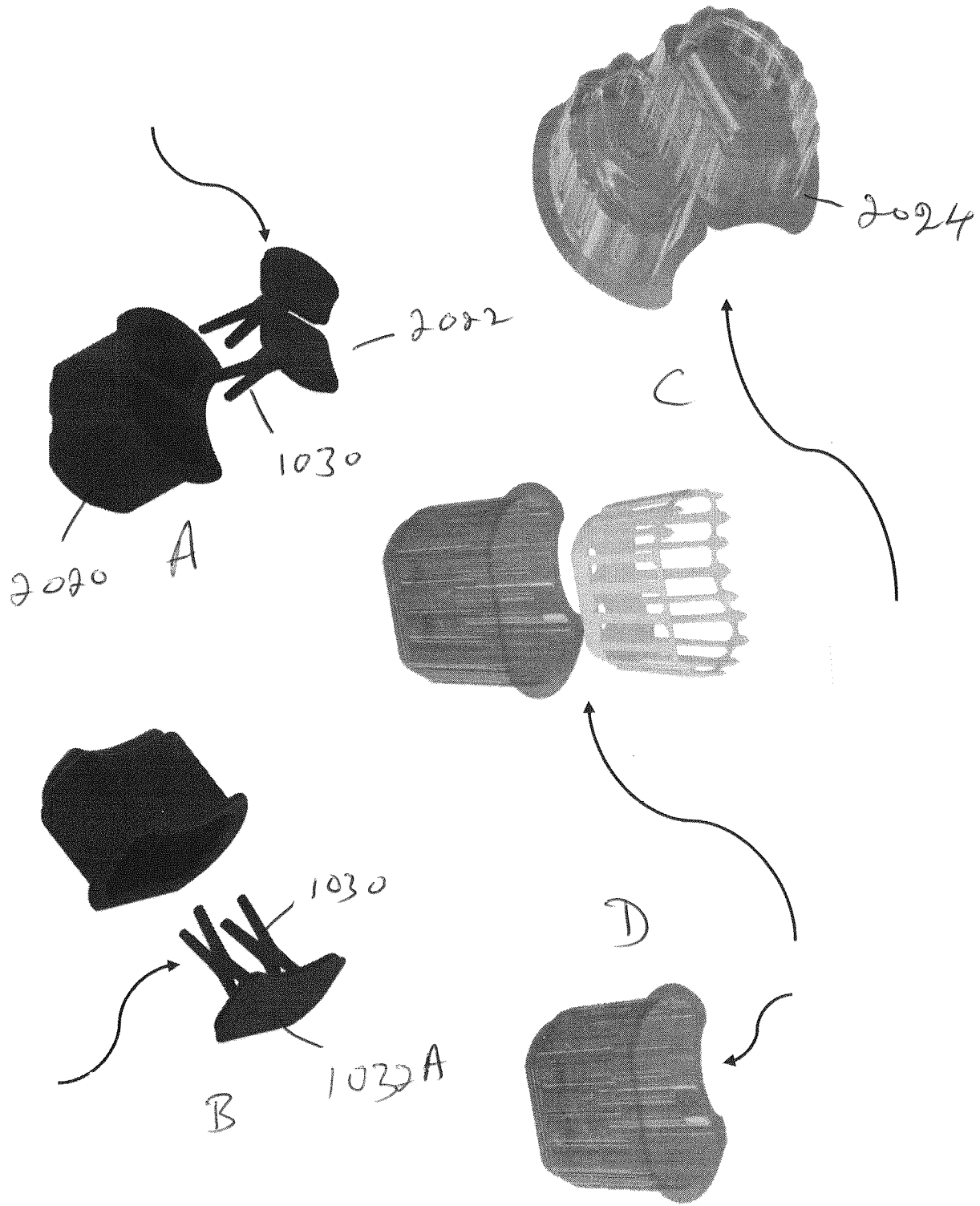

FIG. 35

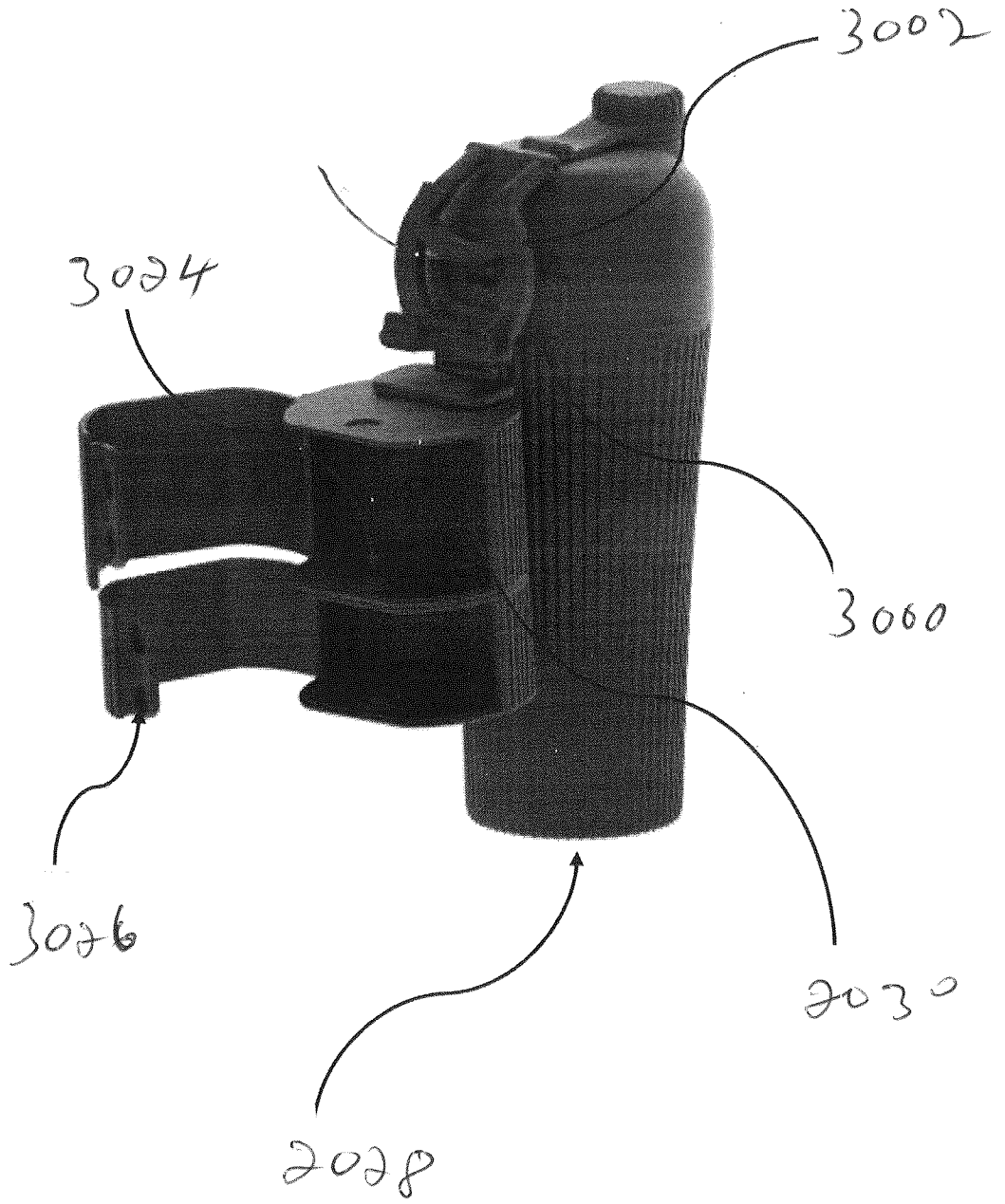

FIG. 3\_6

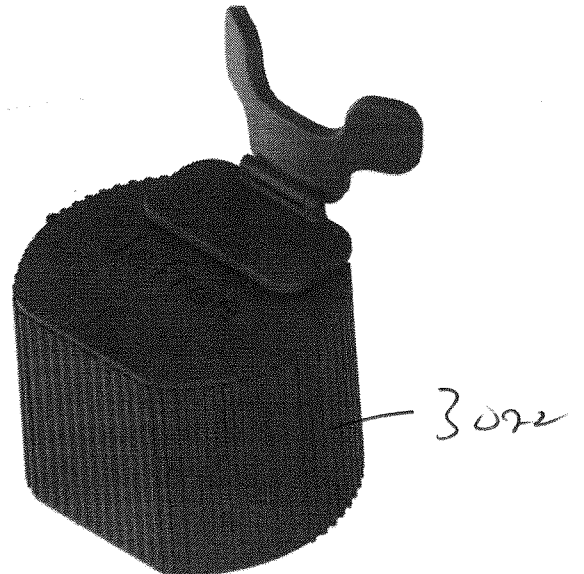
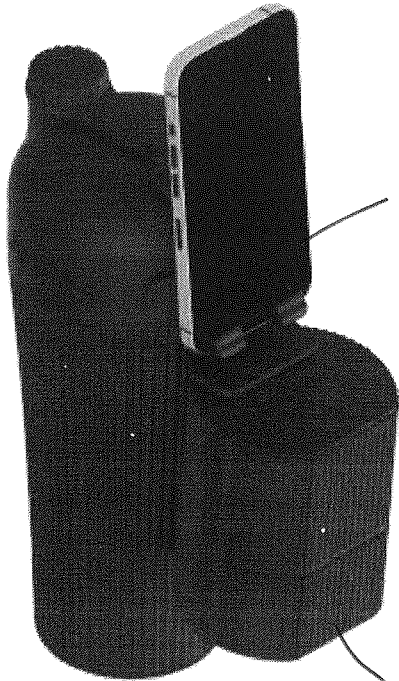

FIG. 37

**INTERNATIONAL SEARCH REPORT**

International application No.  
**PCT/CA2024/050821**

A. CLASSIFICATION OF SUBJECT MATTER  
 IPC: *A47J 43/27* (2006.01), *B65D 51/28* (2006.01)  
  
 CPC: *A47J 43/27* (2020.01), *B65D 51/2821* (2020.01)

According to International Patent Classification (IPC) or to both national classification and IPC

**B. FIELDS SEARCHED**

Minimum documentation searched (classification system followed by classification symbols)  
 IPC: *A47J 43/xx* (2006.01), *B65D 51/28* (2006.01). CPC: *A47J 43/xx* (2020.01), *B65D 51/2821* (2020.01).

Documentation searched other than minimum documentation to the extent that such documents are included in the fields searched

Electronic database(s) consulted during the international search (name of database(s) and, where practicable, search terms used)  
 Questel Orbit [FamPat]

Keywords: pod, capsule, shake, bottle, cap, lid, magnet.

**C. DOCUMENTS CONSIDERED TO BE RELEVANT**

Category*	Citation of document, with indication, where appropriate, of the relevant passages	Relevant to claim No.
X	WO 2023/028655 A1 (ROUX, S.) 09 March 2023 (09-03-2023) *Paragraphs [0024] and [0208]-[0272]*	1, 3, 11-14, 17-19, 22-26, 28-32, 34, 36 and 37
Y	*Figures 1-12*	2, 4-10, 15, 16, 20, 21, 27, 33, 35, 38 and 39
Y	US 2021/0171260 A1 (GISHOLT, P.) 10 June 2021 (10-06-2021) *Paragraphs [0095]-[0098], [0111], [0151] and [0155]* *Figures 1D, 3A, 3D, 5-7 and 10D*	2 and 38-43
X	US 2010/0200437 A1 (COON, D.) 12 August 2010 (12-08-2010) *Paragraphs [0010], [0156], [0157], [0180]	44
Y	*Figures 1A-2 and 4-5C*	4-6 and 40-43

Further documents are listed in the continuation of Box C.  See patent family annex.

* Special categories of cited documents: "A" document defining the general state of the art which is not considered to be of particular relevance "D" document cited by the applicant in the international application "E" earlier application or patent but published on or after the international filing date "L" document which may throw doubts on priority claim(s) or which is cited to establish the publication date of another citation or other special reason (as specified) "O" document referring to an oral disclosure, use, exhibition or other means "P" document published prior to the international filing date but later than the priority date claimed	"T" later document published after the international filing date or priority date and not in conflict with the application but cited to understand the principle or theory underlying the invention "X" document of particular relevance; the claimed invention cannot be considered novel or cannot be considered to involve an inventive step when the document is taken alone "Y" document of particular relevance; the claimed invention cannot be considered to involve an inventive step when the document is combined with one or more other such documents, such combination being obvious to a person skilled in the art "&" document member of the same patent family
--	--

Date of the actual completion of the international search  
 16 August 2024 (16-08-2024)

Date of mailing of the international search report  
 27 August 2024 (27-08-2024)

Name and mailing address of the ISA/CA  
 Canadian Intellectual Property Office  
 Place du Portage I, C114 - 1st Floor, Box PCT  
 50 Victoria Street  
 Gatineau, Quebec K1A 0C9  
 Facsimile No.: 819-953-2476

Authorized officer  
  
 Luc Gollain (819) 639-7808

## INTERNATIONAL SEARCH REPORT

International application No.  
**PCT/CA2024/050821**

C (Continuation). DOCUMENTS CONSIDERED TO BE RELEVANT		
Category*	Citation of document, with indication, where appropriate, of the relevant passages	Relevant to claim No.
Y	US 2010/0288767 A1 (SEELHOFER, F.) 18 November 2010 (18-11-2010) *Paragraphs [0019]-[0026]* *Figures 1-10*	7-9, 27, 33 and 35
Y	US 4,638,927 A (MORANE, B.P.) 27 January 1987 (27-01-1987) *Column 6, line 10 – col. 8, line 8* *Figures 1-4*	15-16, 20 and 21
Y	US2016/0236819 A1 (YURKOVETSKAYA, H., et al.) 18 August 2016 (18-08-2016) *Abstract; paragraph [0027]; figure 1*	10

**INTERNATIONAL SEARCH REPORT**  
Information on patent family members

International application No.  
**PCT/CA2024/050821**

Patent Document Cited in Search Report	Publication Date	Patent Family Member(s)	Publication Date
WO2023028655A1	09 March 2023 (09-03-2023)	None	
US2021171260A1	10 June 2021 (10-06-2021)	AU2019288843A1 BR112020026479A2 CA3104300A1 CA3104514A1 CN113165773A CN113165773B EP3810522A1 EP3810522A4 EP3810543A1 EP3810543A4 IL279628A JP2021528214A JP7426387B2 JP2024038453A KR20210053876A MX2020014246A SG11202012896VA TW202005902A US2021139222A1 US2022194680A1 WO2019246629A1 WO2019246631A1 WO2019246633A1	04 February 2021 (04-02-2021) 23 March 2021 (23-03-2021) 26 December 2019 (26-12-2019) 26 December 2019 (26-12-2019) 23 July 2021 (23-07-2021) 10 November 2023 (10-11-2023) 28 April 2021 (28-04-2021) 03 August 2022 (03-08-2022) 28 April 2021 (28-04-2021) 14 September 2022 (14-09-2022) 01 March 2021 (01-03-2021) 21 October 2021 (21-10-2021) 01 February 2024 (01-02-2024) 19 March 2024 (19-03-2024) 12 May 2021 (12-05-2021) 27 May 2021 (27-05-2021) 25 February 2021 (25-02-2021) 01 February 2020 (01-02-2020) 13 May 2021 (13-05-2021) 23 June 2022 (23-06-2022) 26 December 2019 (26-12-2019) 26 December 2019 (26-12-2019) 26 December 2019 (26-12-2019)
US2010200437A1	12 August 2010 (12-08-2010)	US7874420B2 BRPI1013622A2 CA2751975A1 CN102369148A CN102369148B MX2011008471A WO2010091026A1	25 January 2011 (25-01-2011) 25 October 2016 (25-10-2016) 12 August 2010 (12-08-2010) 07 March 2012 (07-03-2012) 06 August 2014 (06-08-2014) 18 November 2011 (18-11-2011) 12 August 2010 (12-08-2010)
US2010288767A1	18 November 2010 (18-11-2010)	US8672154B2 BRPI0905922A2 BRPI0905922A8 BRPI0905922B1 CN101945813A CN101945813B EP2240382A1 EP2240382B1 ES2401139T3 JP2011511742A JP5388232B2 MX2010008837A PL2240382T3 RU2010133734A RU2506212C2 WO2009100544A1	18 March 2014 (18-03-2014) 23 June 2015 (23-06-2015) 19 April 2016 (19-04-2016) 31 July 2018 (31-07-2018) 12 January 2011 (12-01-2011) 02 January 2013 (02-01-2013) 20 October 2010 (20-10-2010) 12 December 2012 (12-12-2012) 17 April 2013 (17-04-2013) 14 April 2011 (14-04-2011) 15 January 2014 (15-01-2014) 07 September 2010 (07-09-2010) 28 June 2013 (28-06-2013) 20 March 2012 (20-03-2012) 10 February 2014 (10-02-2014) 20 August 2009 (20-08-2009)
US4638927A	27 January 1987 (27-01-1987)	BE902411A CA1275077A CH662327A5 DE3516959A1 FR2564433A1 FR2564433B1	13 November 1985 (13-11-1985) 09 October 1990 (09-10-1990) 30 September 1987 (30-09-1987) 21 November 1985 (21-11-1985) 22 November 1985 (22-11-1985) 03 October 1986 (03-10-1986)

**INTERNATIONAL SEARCH REPORT**  
Information on patent family members

International application No.  
**PCT/CA2024/050821**

Patent Document Cited in Search Report	Publication Date	Patent Family Member(s)	Publication Date
		GB8510833D0 GB2158801A GB2158801B IT1208806B IT8553372V0 JPS61162A	05 June 1985 (05-06-1985) 20 November 1985 (20-11-1985) 24 February 1988 (24-02-1988) 10 July 1989 (10-07-1989) 13 May 1985 (13-05-1985) 06 January 1986 (06-01-1986)
US2016236819A1	18 August 2016 (18-08-2016)	US10105012B2 US2019014949A1 US10307019B2 US2019239697A1 US11147419B2 US2019380541A1 US11185193B2	23 October 2018 (23-10-2018) 17 January 2019 (17-01-2019) 04 June 2019 (04-06-2019) 08 August 2019 (08-08-2019) 19 October 2021 (19-10-2021) 19 December 2019 (19-12-2019) 30 November 2021 (30-11-2021)