



US00D657017S

(12) **United States Design Patent**
Porter

(10) **Patent No.:** **US D657,017 S**

(45) **Date of Patent:** **** Apr. 3, 2012**

(54) **TRIGGER FOR AEROSOL CONTAINER DISCHARGING APPARATUS**

(76) Inventor: **Steven P. Porter**, Elburn, IL (US)

(**) Term: **14 Years**

(21) Appl. No.: **29/372,115**

(22) Filed: **Oct. 15, 2010**

(51) **LOC (9) Cl.** **23-01**

(52) **U.S. Cl.** **D23/226; D9/499**

(58) **Field of Classification Search** D23/213,
D23/223, 226; D9/448, 499; 239/526, 532;
222/174, 402.1, 402.14, 402.15
See application file for complete search history.

(56) **References Cited**

U.S. PATENT DOCUMENTS

2,508,104 A	5/1950	Dickensheets
2,720,422 A	10/1955	Mercur
2,830,742 A	4/1958	Gibbons et al.
2,893,606 A	7/1959	Hawkins
2,960,260 A	11/1960	Kutik
3,017,056 A	1/1962	Bishop
3,050,260 A	8/1962	Macrae et al.
3,229,859 A	1/1966	Conroy et al.
3,485,206 A	12/1969	Smrt
3,510,028 A	5/1970	Batistelli
3,716,195 A	2/1973	Silva
3,856,209 A	12/1974	Hickson
3,861,566 A	1/1975	Wentzell
3,871,557 A	3/1975	Smrt
3,894,816 A	7/1975	Davis et al.
3,977,570 A	8/1976	Smrt
4,023,711 A	5/1977	Sena
4,092,000 A	5/1978	Offutt, III
4,099,482 A	7/1978	Smrt
4,262,821 A	4/1981	Smrt
4,432,474 A *	2/1984	Hutchinson et al. 222/402.15
D827,394	12/1986	Yamamoto
4,660,745 A	4/1987	Hess, Jr.
4,789,084 A	12/1988	Yoshitomi
4,805,812 A	2/1989	Brody

4,886,191 A	12/1989	Yoshitomi
4,932,565 A *	6/1990	Paradiso 222/174
5,086,954 A	2/1992	Brody
D355,824 S	2/1995	Smrt
5,518,148 A	5/1996	Smrt
5,749,522 A	5/1998	Smrt
5,875,926 A	3/1999	Schwartz

(Continued)

Primary Examiner — Robin V Webster

(74) *Attorney, Agent, or Firm* — Meroni & Meroni, P.C.;
Charles F. Meroni, Jr.; Christopher J. Scott

(57) **CLAIM**

The ornamental design for the trigger for aerosol container discharging apparatus, as shown and described.

DESCRIPTION

FIG. 1 is a reduced perspective view of the trigger for aerosol container discharging apparatus shown in the condition of use;

FIG. 2 is a perspective view of the trigger for aerosol container discharging apparatus;

FIG. 3 is a right side elevational view of the trigger for aerosol container discharging apparatus;

FIG. 4 is a left side elevational view of the trigger for aerosol container discharging apparatus;

FIG. 5 is a front end view of the trigger for aerosol container discharging apparatus;

FIG. 6 is a rear end view of the trigger for aerosol container discharging apparatus;

FIG. 7 is a top plan view of the trigger for aerosol container discharging apparatus; and,

FIG. 8 is a bottom plan view of the trigger for aerosol container discharging apparatus.

All broken lines in the drawing views are included for the purpose of illustrating portions of the trigger for aerosol container discharging apparatus that form no part of the claimed design.

1 Claim, 5 Drawing Sheets

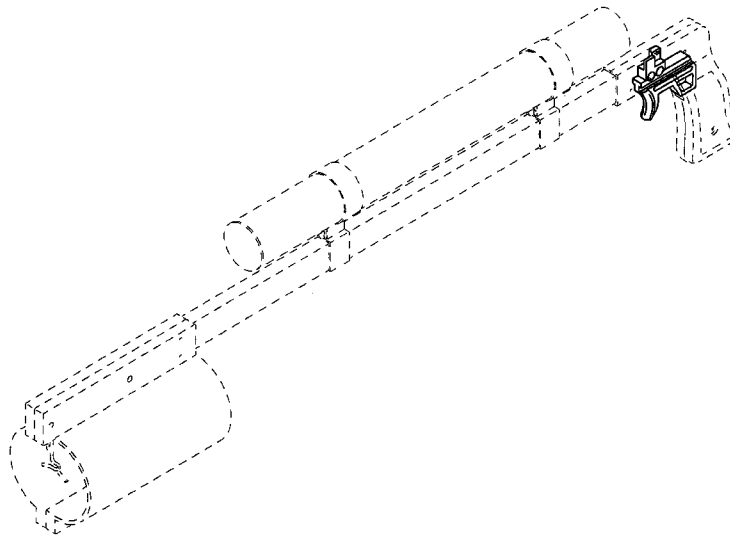

US D657,017 S

Page 2

U.S. PATENT DOCUMENTS

6,053,260	A	4/2000	Boon et al.					
6,364,177	B1 *	4/2002	Taylor	222/473	7,048,151	B1	5/2006	Wertz et al.
6,390,336	B1	5/2002	Orozco		7,076,916	B2	7/2006	Bianchini
6,435,129	B1	8/2002	McDonald et al.		7,316,334	B1 *	1/2008	Brody et al. 222/402.15
6,450,423	B1	9/2002	Gurule		D569,478	S *	5/2008	Cichy et al. D23/223
6,723,375	B2	4/2004	Zeck et al.		D573,689	S *	7/2008	Tullney et al. D23/223
D510,408	S *	10/2005	Bitowft et al.	D23/226	D608,857	S *	1/2010	Chou D23/223
7,040,510	B1 *	5/2006	Hester	222/174	7,644,839	B2 *	1/2010	McNulty, Jr. 222/79
					7,717,300	B1 *	5/2010	Yarrusso, Jr. 222/174

* cited by examiner

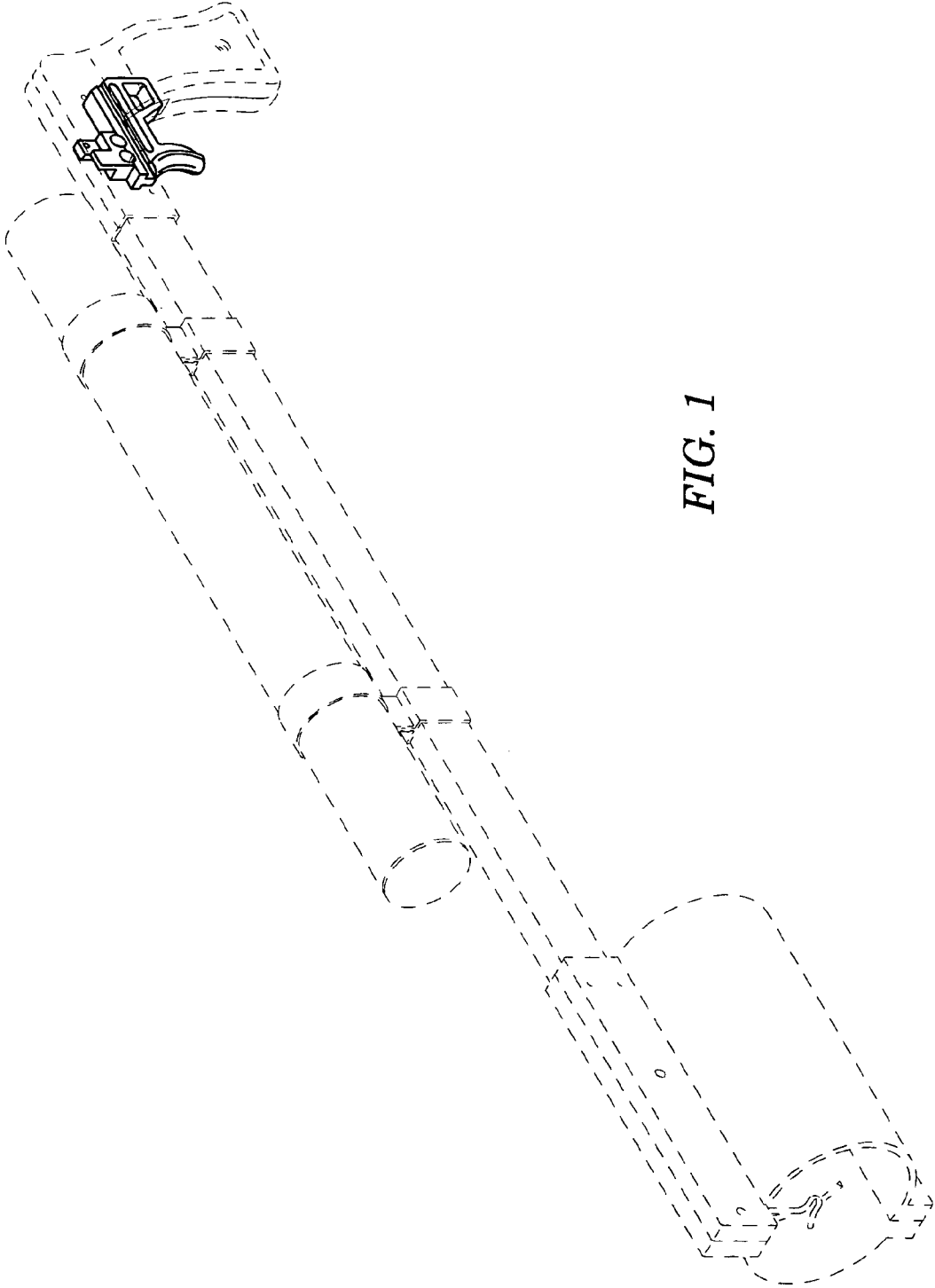

FIG. 1

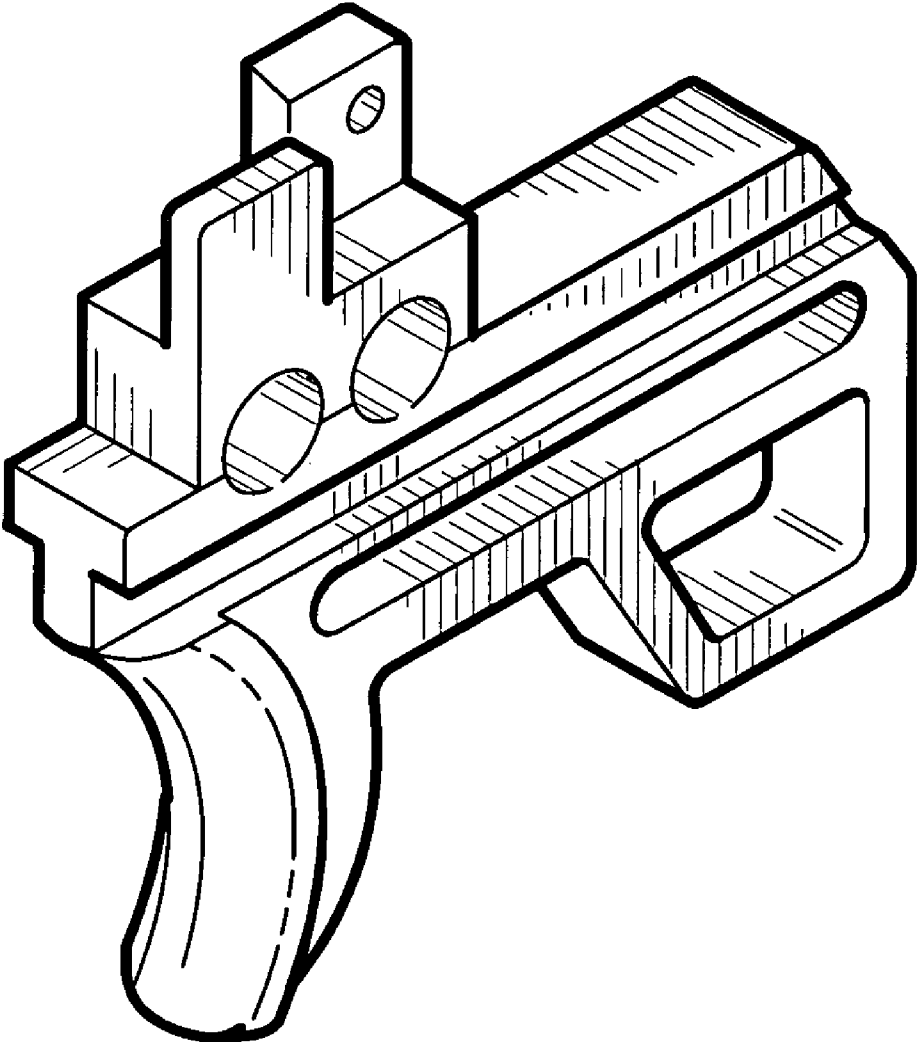

FIG. 2

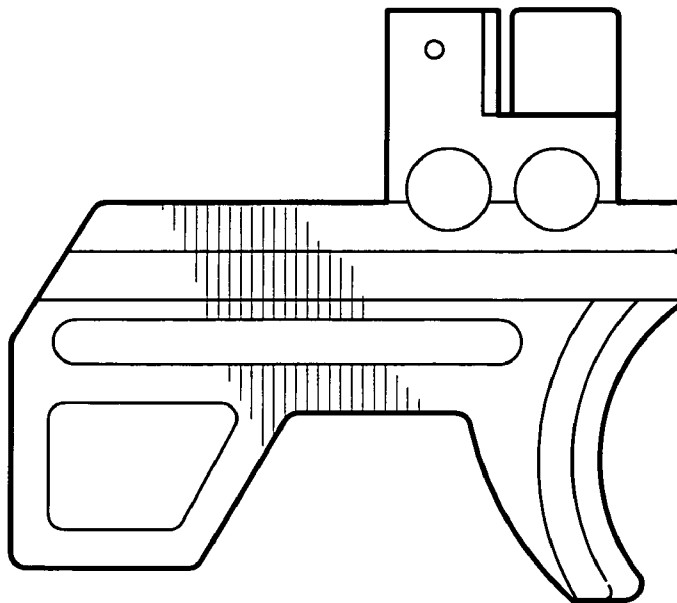
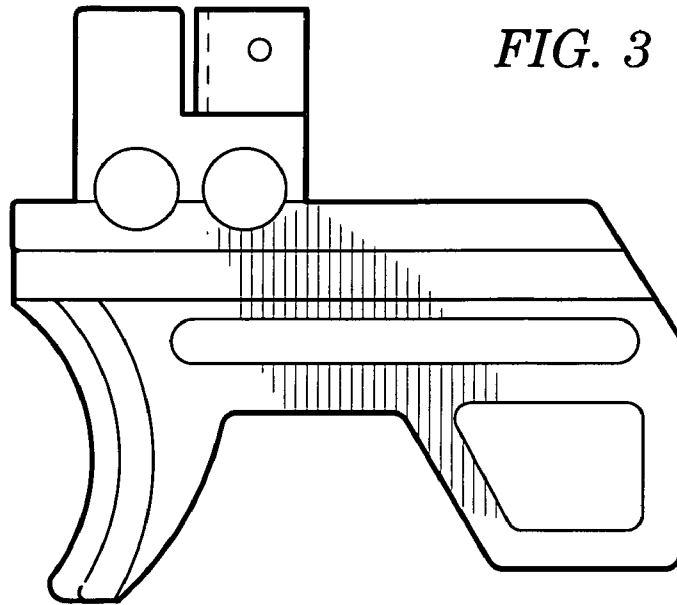

FIG. 5

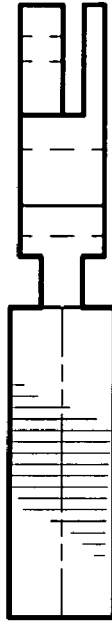
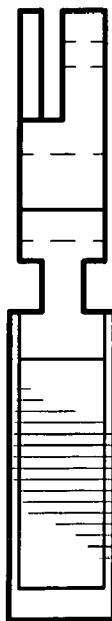

FIG. 6



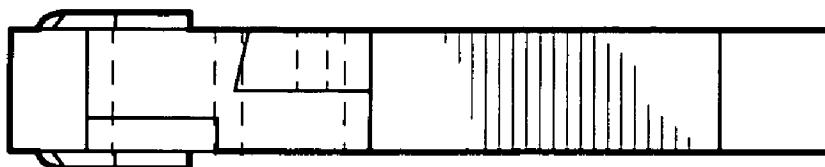

FIG. 7

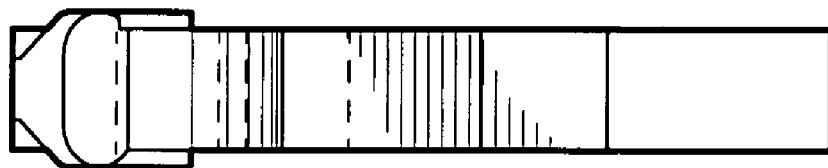

FIG. 8