



- (51) **International Patent Classification:**
H01C 7/12 (2006.01)
- (21) **International Application Number:**
PCT/SI2011/000008
- (22) **International Filing Date:**
18 February 2011 (18.02.2011)
- (25) **Filing Language:** Slovenian
- (26) **Publication Language:** English
- (30) **Priority Data:**
P201000063 19 February 2010 (19.02.2010) SI
- (71) **Applicant (for all designated States except US):** ISKRA
ZASČITE d.o.o. [SI/SI]; Stegne 35, SI-1000 Ljubljana (SI).
- (72) **Inventors; and**
- (75) **Inventors/Applicants (for US only):** BURGER, Miran
[SI/SI]; Merčnikova ulica 5/a, 1111 Ljubljana (SI).
VUKOTIČ, Milenko; Clevelandska 43, 1111 Ljubljana (SI).
JURIČEV, Igor; Smrekarjeva 19, 6310 Izola (SI).
- (74) **Agent:** FLAK, Antonija; Kotnikova 32, p.p. 2706,
SI-1001 Ljubljana (SI).
- (81) **Designated States (unless otherwise indicated, for every
kind of national protection available):** AE, AG, AL, AM,

AO, AT, AU, AZ, BA, BB, BG, BH, BR, BW, BY, BZ, CA, CH, CL, CN, CO, CR, CU, CZ, DE, DK, DM, DO, DZ, EC, EE, EG, ES, FI, GB, GD, GE, GH, GM, GT, HN, HR, HU, ID, IL, IN, IS, JP, KE, KG, KM, KN, KP, KR, KZ, LA, LC, LK, LR, LS, LT, LU, LY, MA, MD, ME, MG, MK, MN, MW, MX, MY, MZ, NA, NG, NI, NO, NZ, OM, PE, PG, PH, PL, PT, RO, RS, RU, SC, SD, SE, SG, SK, SL, SM, ST, SV, SY, TH, TJ, TM, TN, TR, TT, TZ, UA, UG, US, UZ, VC, VN, ZA, ZM, ZW.

- (84) **Designated States (unless otherwise indicated, for every
kind of regional protection available):** ARIPO (BW, GH, GM, KE, LR, LS, MW, MZ, NA, SD, SL, SZ, TZ, UG, ZM, ZW), Eurasian (AM, AZ, BY, KG, KZ, MD, RU, TJ, TM), European (AL, AT, BE, BG, CH, CY, CZ, DE, DK, EE, ES, FI, FR, GB, GR, HR, HU, IE, IS, IT, LT, LU, LV, MC, MK, MT, NL, NO, PL, PT, RO, RS, SE, SI, SK, SM, TR), OAPI (BF, BJ, CF, CG, CI, CM, GA, GN, GQ, GW, ML, MR, NE, SN, TD, TG).

Published:

- with international search report (Art. 21(3))
- before the expiration of the time limit for amending the claims and to be republished in the event of receipt of amendments (Rule 48.2(h))

- (88) **Date of publication of the international search report:**
13 October 2011

(54) **Title:** EXCESS VOLTAGE CIRCUIT-BREAKER WITH A ROTATIONAL DISC AND AN ELECTRONIC ASSEMBLY TO IMPROVE OPERATION RELIABILITY

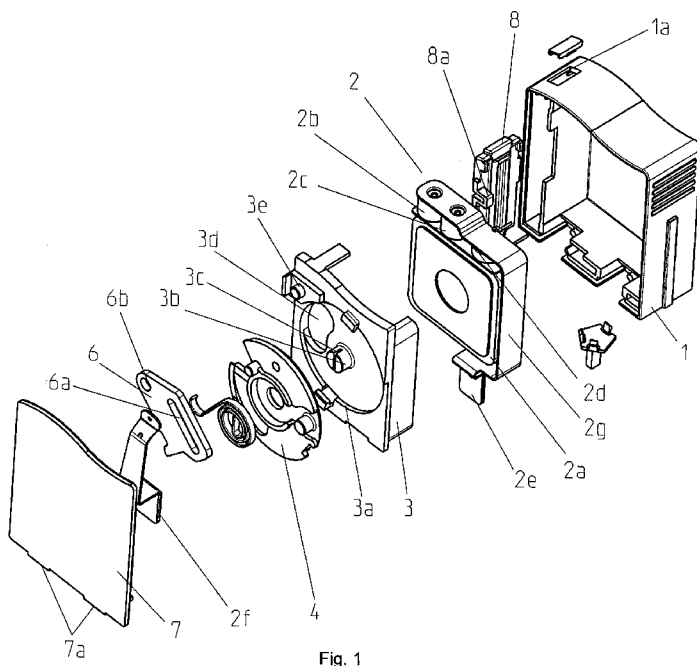

Fig. 1

(57) **Abstract:** The excess voltage circuit breaker with a rotational disc and an electronic assembly to improve operation liability solves a problem of construction of electronic and mechanical disconnection of a connection terminal of an excess voltage protective element based on e. g. spark gaps, varistors, semi-conductors like diodes, thyristors and similar elements in case of occurrence of electric arc and electric thermal overloads. The essence of the excess voltage circuit breaker of the invention lies in an electronic assembly of a component (2) which comprises a resistor (PTC) with positive thermal coefficient which is connected in parallel to a gas circuit breaker (GDT). The resistor (PTC) is a resistor (2d) in the embodiment. The circuit breaker (GDT) comprises two gas circuit breakers (2b and 2c), wherein the common exit point of the resistor (2d) and the circuit breaker (GDT) is via thermal member (V), which is simultaneously a connection electrode (2f) arranged on a varistor (2a) body. The electronic assembly of the component (2) functions in a way that in case of rapid transition events a branch with the gas circuit breaker (GDT) is operable and in case of sporadically increased voltages the branch via the resistor (2d) is operable. The resistor (2d) with positive thermal coefficient limits the current through the varistor (2a). The varistor (2a) in low ohmic state allows high current to run through the varistor (2a) thus enabling the operation of external over-current protection. The movement of the connection electrode (2f) triggers the movement of the rotational disc (4), the spring (5), the latching plate (6) which changes the state of the indicator (8).

ment to run through the varistor (2a) thus enabling the operation of external over-current protection. The movement of the connection electrode (2f) triggers the movement of the rotational disc (4), the spring (5), the latching plate (6) which changes the state of the indicator (8).

WO 2011/102811 A3

INTERNATIONAL SEARCH REPORT

International application No PCT/SI2011/000008

A. CLASSIFICATION OF SUBJECT MATTER INV. H01C7/12 ADD.		
According to International Patent Classification (IPC) or to both national classification and IPC		
B. FIELDS SEARCHED		
Minimum documentation searched (classification system followed by classification symbols) H01C H02H		
Documentation searched other than minimum documentation to the extent that such documents are included in the fields searched		
Electronic data base consulted during the international search (name of data base and, where practical, search terms used) EPO-Internal, WPI Data		
C. DOCUMENTS CONSIDERED TO BE RELEVANT		
Category*	Citation of document, with indication, where appropriate, of the relevant passages	Relevant to claim No.
A	DE 196 23 541 A1 (ABB RESEARCH LTD [CH]) 18 December 1997 (1997-12-18) column 2, line 68 - column 5, line 36 figures 1,2c -----	1-4
A	US 2003/086235 A1 (BENNETT ROBERT J [US] ET AL) 8 May 2003 (2003-05-08) paragraph [0047] - paragraph [0056]; figures 9-12 -----	1-4
A	DE 10 2008 013448 A1 (DEHN & SOEHNE [DE]) 7 May 2009 (2009-05-07) cited in the application paragraphs [0042], [0046] - paragraph [0053]; figure 2a -----	1-4
<input type="checkbox"/> Further documents are listed in the continuation of Box C. <input checked="" type="checkbox"/> See patent family annex.		
* Special categories of cited documents :		
"A" document defining the general state of the art which is not considered to be of particular relevance "E" earlier document but published on or after the international filing date "L" document which may throw doubts on priority claim(s) or which is cited to establish the publication date of another citation or other special reason (as specified) "O" document referring to an oral disclosure, use, exhibition or other means "P" document published prior to the international filing date but later than the priority date claimed	"T" later document published after the international filing date or priority date and not in conflict with the application but cited to understand the principle or theory underlying the invention "X" document of particular relevance; the claimed invention cannot be considered novel or cannot be considered to involve an inventive step when the document is taken alone "Y" document of particular relevance; the claimed invention cannot be considered to involve an inventive step when the document is combined with one or more other such documents, such combination being obvious to a person skilled in the art. "&" document member of the same patent family	
Date of the actual completion of the international search	Date of mailing of the international search report	
12 August 2011	22/08/2011	
Name and mailing address of the ISA/ European Patent Office, P.B. 5818 Patentlaan 2 NL - 2280 HV Rijswijk Tel. (+31-70) 340-2040, Fax: (+31-70) 340-3016	Authorized officer Sedlmaier, Stefan	

INTERNATIONAL SEARCH REPORT

Information on patent family members

International application No PCT/SI2011/000008

Patent document cited in search report	Publication date	Patent family member(s)	Publication date
DE 19623541	A1	18-12-1997	AU 2502297 A WO 9748159 A1
			07-01-1998 18-12-1997

US 2003086235	A1	08-05-2003	BR 0207050 A CA 2409470 A1 MX PA02010616 A US 2004228064 A1
			25-11-2003 08-05-2003 19-05-2003 18-11-2004

DE 102008013448	A1	07-05-2009	AT 512444 T EP 2208208 A1 WO 2009056587 A1
			15-06-2011 21-07-2010 07-05-2009
