

- [54] **SPACE COVERING ASSEMBLY** 960,256 1964 Great Britain ..... 312/137
- [76] **Inventor: Lawrence H. Mathias, P.O. Box 172, Dover, Ohio 44622**
- [22] **Filed: Jan. 7, 1972**
- [21] **Appl. No.: 216,095**
- [52] **U.S. Cl. .... 312/140.4, 52/98**
- [51] **Int. Cl. .... A47b 96/18, A47f 9/00**
- [58] **Field of Search .... 312/140.4, 137; 52/98, 99, 465, 466, 468**

*Primary Examiner*—Paul R. Gilliam  
*Attorney*—Harvey B. Jacobson et al.

- [56] **References Cited**
- UNITED STATES PATENTS**
- 1,155,149 9/1915 Hathorne ..... 312/137
- 3,470,662 10/1969 Kellman ..... 52/99
- 2,641,805 6/1953 Spector et al. .... 52/98 X
- FOREIGN PATENTS OR APPLICATIONS**
- 806,089 1958 Great Britain ..... 52/466

[57] **ABSTRACT**

A space covering assembly for use with adjacent cabinets separated by an open space, said assembly comprising a one-piece flat molded plastic panel with a plurality of cuts or break lines on one side, a pair of fastening pegs integral with said panel and extending from the one side thereof, and a pair of mounting blocks having fastening apertures therein for retentively receiving the fastening pegs, said mounting blocks being of easily cuttable material for sizing to snugly fit into the space separating the cabinets.

**4 Claims, 6 Drawing Figures**

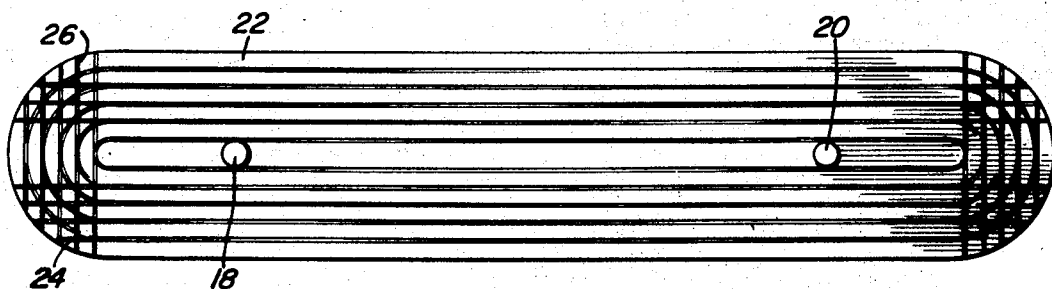

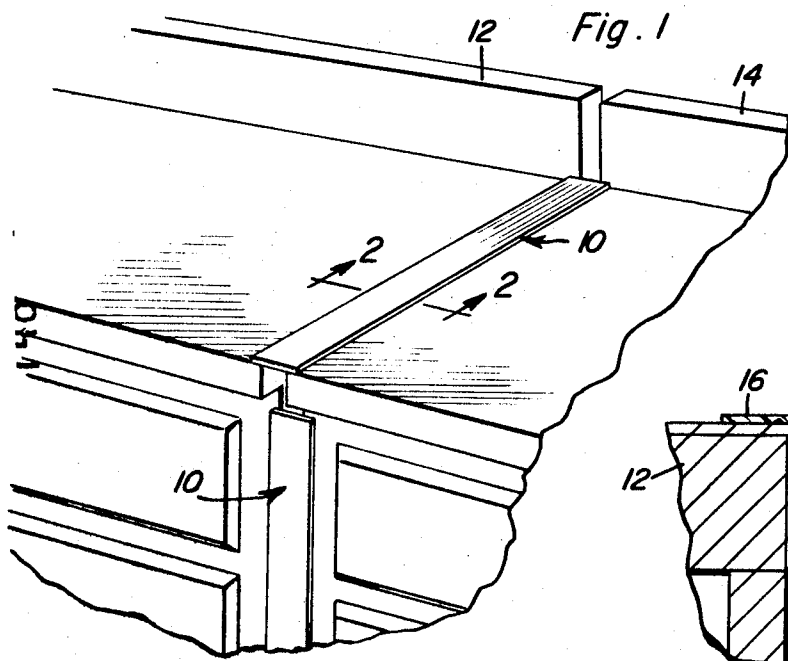

Fig. 1

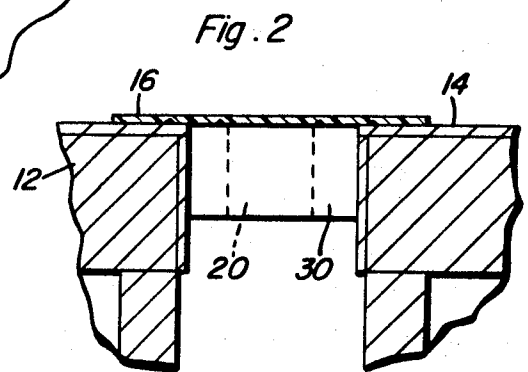

Fig. 2

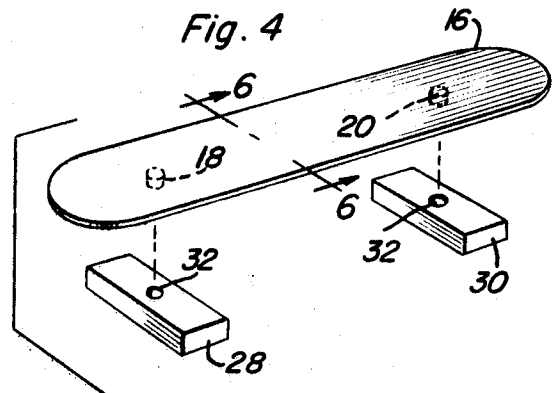

Fig. 4

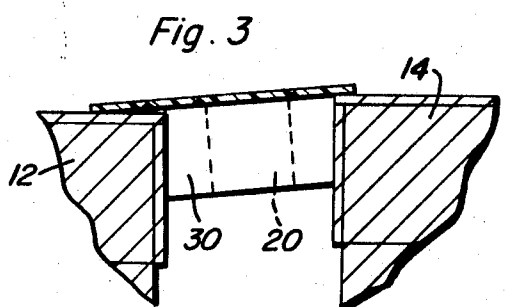

Fig. 3

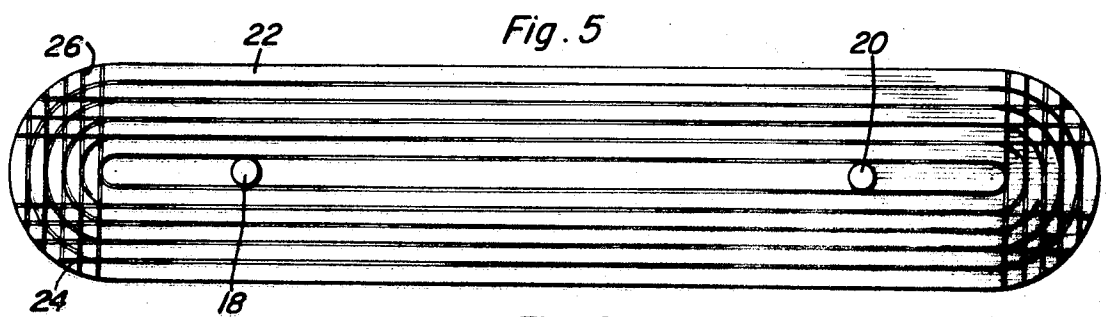

Fig. 5

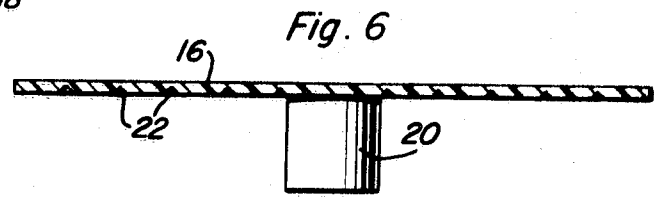

Fig. 6

## SPACE COVERING ASSEMBLY

The present invention is generally related to cabinetry and, more particularly, to a unique space covering assembly for conveniently eliminating the opened spaces separating adjacent cabinets, appliances or the like.

It is an object of the present invention to provide a novel covering panel for the spaces separating adjacent cabinets or the like and being extremely easy for an individual to install in a minimum amount of time and without the use of special tools, yet providing an installation which is neat and attractive in appearance.

Another object of the present invention is to provide a unique space covering assembly including a relatively thin, flat panel with break or cut lines on one side thereof for convenient sizing relative to the space to be covered, thereby eliminating the necessity of time-consuming measurements and the cutting with special tools.

It is a further object of the present invention to provide a versatile space covering assembly which may be made of molded plastic or similar materials, is light weight, attractive in appearance, easy to install, and relatively economical to manufacture.

These together with other objects and advantages which will become subsequently apparent reside in the details of construction and operation as more fully hereinafter described and claimed, reference being had to the accompanying drawings forming a part hereof, wherein like numerals refer to like parts throughout.

FIG. 1 is a partial perspective view of a pair of the space covering assemblies of the present invention mounted between a pair of typical kitchen cabinets.

FIG. 2 is an enlarged sectional view taken along section 2-2 of FIG. 1.

FIG. 3 is a sectional view similar to FIG. 2 but with the adjacent cabinets being of different heights.

FIG. 4 is an exploded perspective view of the space covering assembly prior to sizing and installation.

FIG. 5 is a bottom view of the flat panel associated with the present invention.

FIG. 6 is an enlarged sectional view taken along section 6-6 of FIG. 4.

Referring now, more particularly, to the drawings, the space covering assembly of the present invention is generally indicated by the numeral 10 and is illustrated as being installed between a pair of adjacent cabinets 12 and 14 shown in FIG. 1. It is not intended that the space covering assembly of the present invention be limited to installations between the illustrated cabinets, it being apparent that installations may be made to cover nearly any elongated opening separating relatively flat surfaces. As such, the assembly may be installed between adjacent pieces of machinery, appliances, or the like.

The assembly is comprised of a relatively flat, thin, elongated panel 16, preferably of molded plastic construction with a pair of spaced fastening pegs 18 and 20 extending outwardly from one side thereof. The bottom side of the panel is provided with a plurality of spaced longitudinal break lines 22 which are defined by indentations to provide weakened areas along the length of the panel. As such, once the proper panel width has been decided upon, the panel may be either cut or

flexed by an individual's hands to produce breaks in the material along the desired break lines. The panel is further provided with a plurality of spaced transverse break lines 24 and curved, semi-circular break lines 26 which may be utilized to provide the proper length and shape of the panel for a particular installation.

A pair of mounting blocks 28 and 30 are provided for mounting the panel relative to the cabinet space by way of fastening apertures 32 in each mounting block for retentively receiving a corresponding fastening peg 18 and 20. Each mounting block is formed from easily cuttable material, such as wood or plastic, to provide convenient sizing for snug engagement with the oppositely disposed cabinet surfaces as illustrated in FIGS. 2 and 3. It will be appreciated that the mounting blocks may be cut on an angle to permit installation between cabinet tops of different height, as best illustrated in FIG. 3.

From the foregoing description it will be appreciated that installation of the space covering assembly of the present invention merely requires that an individual size the panel by flexing or cutting along the appropriate break lines, cut the mounting blocks to the proper width, and snap the mounting blocks onto the fastening pegs prior to positioning in the cabinet space. The panel may be made in many different colors and surface textures to provide an attractive, durable, easily washable surface overlying the cabinet space.

The foregoing is considered as illustrative only of the principles of the invention. Further, since numerous modifications and changes will readily occur to those skilled in the art, it is not desired to limit the invention to the exact construction and operation shown and described, and accordingly all suitable modifications and equivalents may be resorted to, falling within the scope of the invention.

What is claimed is:

1. In combination: a cover assembly and a pair of adjacent cabinets separated by an open space; said assembly comprising a substantially flat, elongated, one-piece molded plastic panel, a pair of spaced fastening pegs integral with said panel and extending outwardly therefrom, a pair of mounting blocks made of easily cuttable material each having a fastening aperture retentively receiving a different one of said fastening pegs, each of said blocks being disposed in the space separating the cabinets with opposite end surfaces in abutting engagement with surfaces on said cabinets, and a plurality of both longitudinally and transversely intersecting spaced break lines on one side of said panel to permit convenient sizing of said panel relative to said open space.

2. The structure set forth in claim 1 wherein said break lines are defined by thin elongated indentations providing reduced cross-sectional thickness to aid in selectively breaking said panel for proper transverse sizing.

3. The structure set forth in claim 1 wherein said break lines are defined by V-shaped cross-sectional indentations in said panel.

4. The structure set forth in claim 1 wherein said fastening pegs are frictionally fitted into said apertures for convenient insertion and removal, as desired.

\* \* \* \* \*