

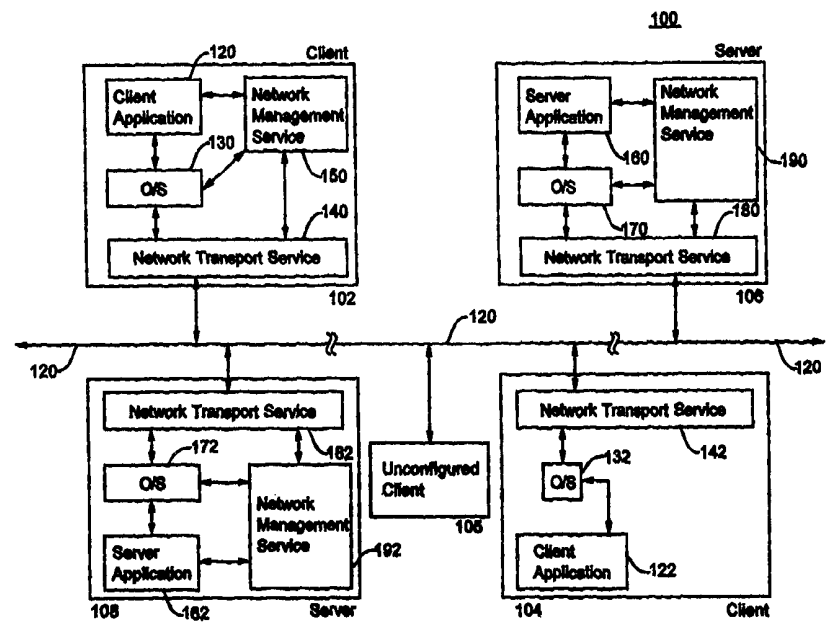

INTERNATIONAL APPLICATION PUBLISHED UNDER THE PATENT COOPERATION TREATY (PCT)

<p>(51) International Patent Classification ⁶ : G06F 11/00</p>	<p>A1</p>	<p>(11) International Publication Number: WO 99/10808 (43) International Publication Date: 4 March 1999 (04.03.99)</p>
<p>(21) International Application Number: PCT/US98/12388 (22) International Filing Date: 15 June 1998 (15.06.98) (30) Priority Data: 08/916,494 22 August 1997 (22.08.97) US (71) Applicant: INTEL CORPORATION [US/US]; 2200 Mission College Boulevard, Santa Clara, CA 95054 (US). (72) Inventors: DAY, Michael, D., II; 1339 North 150 West, American Fork, UT 84003 (US). BUTT, Alan, B.; 1786 North 900 West, Orem, UT 84057 (US). BELISLE, Stephen, W.; 3601 E. Hughes Canyon Circle, Salt Lake City, UT 84121 (US). WINTERTON, Richard, R.; 3480 North Brookside Drive, Provo, UT 84604 (US). (74) Agents: TAYLOR, Edwin, H. et al.; Blakely, Sokoloff, Taylor & Zafman LLP, 7th floor, 12400 Wilshire Boulevard, Los Angeles, CA 90025 (US).</p>		<p>(81) Designated States: AL, AM, AT, AT (Utility model), AU (Petty patent), AZ, BA, BB, BG, BR, BY, CA, CH, CN, CU, CZ, CZ (Utility model), DE, DE (Utility model), DK, DK (Utility model), EE, EE (Utility model), ES, FI, FI (Utility model), GB, GE, GH, GM, GW, HU, ID, IL, IS, JP, KE, KG, KP, KR, KZ, LC, LK, LR, LS, LT, LU, LV, MD, MG, MK, MN, MW, MX, NO, NZ, PL, PT, RO, RU, SD, SE, SG, SI, SK, SK (Utility model), SL, TJ, TM, TR, TT, UA, UG, UZ, VN, YU, ZW, ARIPO patent (GH, GM, KE, LS, MW, SD, SZ, UG, ZW), Eurasian patent (AM, AZ, BY, KG, KZ, MD, RU, TJ, TM), European patent (AT, BE, CH, CY, DE, DK, ES, FI, FR, GB, GR, IE, IT, LU, MC, NL, PT, SE), OAPI patent (BF, BJ, CF, CG, CI, CM, GA, GN, ML, MR, NE, SN, TD, TG).</p> <p>Published <i>With international search report. Before the expiration of the time limit for amending the claims and to be republished in the event of the receipt of amendments.</i></p>

(54) Title: METHOD AND APPARATUS FOR FACILITATING THE MANAGEMENT OF NETWORKED DEVICES



(57) Abstract

A network management service (150) for facilitating the management of networked devices by network management applications (a.k.a., agents) is described. In a first embodiment, the network management service (150) for facilitating the management of networked devices by network management applications (a.k.a., agents) comprises an agent discovery service (202) for discovering and registering remote management agents and a file transfer service (204) operative to send information to and receive information from remote systems.

FOR THE PURPOSES OF INFORMATION ONLY

Codes used to identify States party to the PCT on the front pages of pamphlets publishing international applications under the PCT.

AL	Albania	ES	Spain	LS	Lesotho	SI	Slovenia
AM	Armenia	FI	Finland	LT	Lithuania	SK	Slovakia
AT	Austria	FR	France	LU	Luxembourg	SN	Senegal
AU	Australia	GA	Gabon	LV	Latvia	SZ	Swaziland
AZ	Azerbaijan	GB	United Kingdom	MC	Monaco	TD	Chad
BA	Bosnia and Herzegovina	GE	Georgia	MD	Republic of Moldova	TG	Togo
BB	Barbados	GH	Ghana	MG	Madagascar	TJ	Tajikistan
BE	Belgium	GN	Guinea	MK	The former Yugoslav Republic of Macedonia	TM	Turkmenistan
BF	Burkina Faso	GR	Greece	ML	Mali	TR	Turkey
BG	Bulgaria	HU	Hungary	MN	Mongolia	TT	Trinidad and Tobago
BJ	Benin	IE	Ireland	MR	Mauritania	UA	Ukraine
BR	Brazil	IL	Israel	MW	Malawi	UG	Uganda
BY	Belarus	IS	Iceland	MX	Mexico	US	United States of America
CA	Canada	IT	Italy	NE	Niger	UZ	Uzbekistan
CF	Central African Republic	JP	Japan	NL	Netherlands	VN	Viet Nam
CG	Congo	KE	Kenya	NO	Norway	YU	Yugoslavia
CH	Switzerland	KG	Kyrgyzstan	NZ	New Zealand	ZW	Zimbabwe
CI	Côte d'Ivoire	KP	Democratic People's Republic of Korea	PL	Poland		
CM	Cameroon	KR	Republic of Korea	PT	Portugal		
CN	China	KZ	Kazakstan	RO	Romania		
CU	Cuba	LC	Saint Lucia	RU	Russian Federation		
CZ	Czech Republic	LI	Liechtenstein	SD	Sudan		
DE	Germany	LK	Sri Lanka	SE	Sweden		
DK	Denmark	LR	Liberia	SG	Singapore		
EE	Estonia						

**METHOD AND APPARATUS FOR
FACILITATING THE MANAGEMENT OF NETWORKED DEVICES**

The present application is a continuation-in-part of application number 08/623,773 entitled Method and Apparatus for Discovering Server Applications in a Network of Computer Systems by Allan B. Butt and Michael D. Day II, and commonly assigned to the assignee of the present invention.

BACKGROUND OF THE INVENTION

1. Field of the Invention

The present invention relates to the field of networked systems and, in particular, to a method and apparatus for facilitating the management of networked devices.

2. Background Information

Networking of computing elements and, in particular, the implementation of client/server networks, wherein the client is the initiating node and the server is the responding node (i.e., not necessarily referring to a file "server" or an application "server"), are known. Examples of these networks include local area networks (LANS), wide area networks (WANS), global networks (Internet), and the networking of telecommunications devices (i.e., cellular networks, PCS networks, wireline telephony networks), and the like. Many of these networks comprise a variety of client computers having different processor architectures and Operating Systems (OS) using Transmission Control Protocol/Internet Protocol (TCP/IP), Internetwork Packet eXchange (IPX), and User Datagram Protocol/Internet Protocol (UDP/IP), or other suitable networking protocols (cumulatively referred to as the Internet communication suite) to produce a seemingly transparent network. Although it may appear to an end-user that the network is seemingly indifferent to computer type (e.g., Intel®-based PC, a Macintosh, or a UNIX system), the useable interface to the network protocols providing the communication interface

between the heterogeneous computer systems still rely on the host OS. Therefore, for each of the popular OS, a corresponding "flavor" of the Internet communication suite must be developed in order to network a host computer system operating with any of these OS.

Thus, despite this seemingly transparent operation, the reality is that these heterogeneous computer networks can be very cumbersome to manage and, consequently, expensive to maintain. While the standards-based communication protocols of the Internet communication suite (e.g., TCP/IP, UDP/IP, IPX) have facilitated the promulgation of such heterogeneous networks, those who manage these networks must duplicate a number of resources to account for a variety of processor architectures and corresponding OS disposed throughout the network. That is to say that the file management, processor communications and the interface to the network communication suite rely on the OS as the user interface to provide a functional computer system (at least from the perspective of the end-user). Accordingly, in most instances where the OS "hangs" (i.e., seemingly "freezes" in an unrecoverable state), the user is, in essence, locked out from the operational state of the computer and the only recourse is to restart the OS (e.g., by rebooting the computer).

Producers and consumers of computer systems have begun to quantify the costs associated with the purchase and maintenance of computer systems and, to some, the results are surprising. One generalization drawn from such study is that the initial cost of purchasing a computer system and software (regardless of size and complexity) is quite small compared to the cost of maintaining such systems. That is to say, the cost of system management, lost productivity due to computer/network downtime and the like are significantly higher than the initial cost of purchasing the hardware and software elements comprising the network.

It is not surprising then, that consumers of large networks of computing devices are placing more pressure on the computing industry to drive down the cost associated with the management and maintenance associated with computer systems, i.e., to reduce the total cost of ownership (TCO) associated with the

purchase and maintenance of the computer systems. Despite their best efforts, however, prior art network management solutions (sometimes referred to as network management tools) to these problems have not had a significant impact on reducing the total cost of ownership.

While the introduction of these tools have improved the general state of network management, fundamental limitations in their effectiveness remain. An example of one such inherent limitation in prior art management tools is the fact that they rely on an operational operating system (OS) at the client computer. That is to say, the prior art network management tools are unable to interface with a "frozen" client computer, much less perform remote diagnostics and maintenance on a client computer in such a state. Rather, many of the prior art management tools created by third party developers merely generate usage statistics, or information readily available from networked computers (or the individual processors of the networked computers), i.e., they merely collect and provide commonly available information via a graphical user interface (GUI).

To further illustrate this limitation with an example, if a user calls a corporate help desk complaining of computer problems, and the network manager determines that the user's OS is "frozen", there is little the network manager can do remotely via the network management software. Consequently, the network manager is often relegated to the rather impotent suggestion of having the user "reboot" the computer and, consequently, losing all of the data stored in volatile memory (i.e., not saved on the hard drive).

Thus a need exists for a method and apparatus for facilitating the management of networked devices, unencumbered by the deficiencies and limitations commonly associated with the prior art.

SUMMARY OF THE INVENTION

In accordance with the teachings of the present invention, a network management service for facilitating the management of networked devices by network management applications (a.k.a., agents) is described. The network

management service comprises an agent discovery service for discovering and registering remote management agents, and a file transfer service operative to send information to and receive information from remote systems.

BRIEF DESCRIPTION OF THE DRAWINGS

The present invention will be described by way of exemplary embodiments, but not limitations, illustrated in the accompanying drawings in which like references denote similar elements, and in which:

Figure 1 is a block diagram illustrating an example network of computer systems incorporated with the teachings of the present invention;

Figure 2 is a block diagram of a network management service incorporated with the teachings of the present invention;

Figure 3 is an illustration of a simple file transfer datagram used to communicate between network management services;

Figure 4 is a flow chart depicting the method steps for pushing a file from a client to a server utilizing the network management service of **Figure 2**;

Figure 5 is a flow chart depicting the method steps for pulling a file from a server to a client utilizing the network management service of **Figure 2**;

Figure 6 is an illustration of a remote execution datagram used to communicate between network management services;

Figure 7 is a flow chart depicting the method steps of one example of remotely configuring an unconfigured client utilizing a network management service, in accordance with the teachings of the present invention;

Figure 8 is a block diagram illustrating an example of an unconfigured client computer;

Figure 9 is a block diagram depicting the method steps of **Figure 7** from a high-level network architecture view; and

Figure 10 is a flow chart illustrating the method steps for enabling remote power management using the network management service of **Figure 2**, in accordance with the teachings of the present invention.

DETAILED DESCRIPTION

In the following description, for purposes of explanation, specific numbers, materials and configurations are set forth in order to provide a thorough understanding of the present invention. However, it will be apparent to one skilled in the art that the present invention may be practiced without the specific details. In other instances, well known features are omitted or simplified in order not to obscure the present invention. Furthermore, for ease of understanding, certain method steps are delineated as separate steps, however, these separately delineated steps should not be construed as necessarily order dependent in their performance.

Referring now to **Figure 1**, a block diagram of an example network of computer systems incorporating the teachings of the present invention is depicted. In one embodiment, for example, network **100** is comprised of a plurality of computing elements, at least a subset of which include the teachings of the present invention. In particular, at least a subset of the computing elements comprising network **100** are disposed with an innovative network management service, incorporated with the teachings of the present invention, enabling an improved level of network manageability and interoperability independent of the myriad of operating systems that may reside within network **100**. As will be described more fully below, the network management service incorporating the teachings of the present invention enables a network management application (also commonly referred to as network management agent, or NMA), for example, to interrogate and manipulate a client computer independent of the particular type of operating system (OS) resident on the client computer. In one embodiment, for example, a network management agent may initialize the network management service of the present invention to automatically populate a client computer located within network **100** with a new/updated operating system, and/or replaces an operating system on a client computer within network **100** that has become inoperative.

As depicted in **Figure 1**, network **100** is shown comprising clients **102** and **104**, and servers **106** and **108**, interconnected to each other via network medium **120**. In one embodiment, clients **102** and **104** are personal computer

systems, while in an alternate embodiment, clients **102** and **104** are telecommunication network devices. As illustrated in **Figure 1**, network medium **120** is intended to represent a broad category of networking infrastructure including network cables and their associated switching (routing), repeater, and/or delay elements, suitable for a high speed local area network (LAN), or a slower speed wide area network (WAN), or public network (i.e., Internet) implementations known in the art. Although certain computing elements of network **100** are labeled as servers **106** and **108** while other computing elements are labeled as clients **102** and **104**, those skilled in the art will recognize that these labels are for the purpose of illustration and ease of understanding only. The term server includes but is not necessarily limited to a "file" server or an "application" server.

In one embodiment of the present invention, clients **102** and **104** include client application(s) **120** and **122**, client operating system (OS) **130** and **132**, network transport services **140** and **142** (sometimes referred to as the transport layer), operatively coupled as depicted. In one embodiment of the present invention, client **102** is shown further comprising network management service **150** incorporated with the teachings of the present invention. As will be discussed in greater detail below, a network management service (e.g., network management service **150**) may be beneficially incorporated into each of the computing elements of network **100**, however, as depicted in **Figure 1**, a network management service need not be fully disposed in every client or server in order for network **100** to benefit from the present invention.

Continuing with **Figure 1**, as illustrated, client applications **120** and **122** are intended to represent any number of a wide variety of applications, in particular, management applications such as Client Manager and Work Group Manager, available from Intel Corp., of Santa Clara, California. As depicted, client applications **120** and **122** rely on operating systems **130** and **132**, respectively, to interface with network transport services **140** and **142** and, ultimately, with network medium **120**. In one embodiment, as will be discussed in greater detail below, client application **120** may alternatively interface with network medium **120** via network management service **150** and network transport service **140** as shown.

Similarly, operating systems **130** and **132** are intended to represent a wide variety of operating systems common to a corresponding variety of computing platforms. Examples of such operating systems include the UNIX operating system, Windows™ based operating systems (e.g., Windows™ 3.1, Windows™ 95, Windows™ NT and Windows™ CE), the Macintosh™ and NeXTStep™ operating systems, and the like.

Network transport services **140** and **142** perform their conventional function of physically sending and receiving information over the network medium, as known in the art. In one embodiment the form of the information exchange is through a message packet. In one embodiment, for example, the message packet is a datagram, the structure of which will be discussed more fully below in **Figure 3**. As illustrated, network transport services **140** and **142** are intended to represent a broad category of transport services known in the art. Examples of such network transport services include Internetwork Packet eXchange (IPX), User Datagram Protocol/Internet Protocol (UDP/IP), NetBEUI, NetBIOS over IP, NetBIOS over IPX, and the like.

In addition to clients **102** and **104**, network **100** is also comprised of servers **106** and **108**, which include server applications **160** and **162**, server operating system **170** and **172**, network transport services **180** and **182**, and network management services **190** and **192** incorporating the teachings of the present invention, respectively. In an alternate embodiment, to be discussed more fully below, not all of the plurality of servers **106** and **108** need to have its own network management service. So long as a network management service is disposed within the network, the clients/servers of the network may benefit from some measure of the functionality that network management service provides.

As illustrated in **Figure 1**, servers **106** and **108** include server applications **160** and **162**, operating systems **170** and **172**, and network transport services **180** and **182** each of which are intended to represent a broad category of applications, operating systems and network transport services known in the art.

Consequently, they will not be discussed further. On the other hand, network management services (e.g., network management services **150**, **190** and **192**) incorporating the teachings of the present invention, comprise a plurality of services which enable, for example, network management applications to interact with network elements independent of the operating systems resident on those network elements.

Turning, then, to **Figure 2**, a block diagram depicting one example of a network management service (i.e., network management service **200**) is shown. In one embodiment of the present invention, network management service **200** may be beneficially incorporated into network **100** as, for example, network management service **150**, **190** and/or **192**. In one embodiment, network management service **200** is shown comprising agent discovery service **202**, simple file transfer service **204** and remote execution service **206**. In another embodiment of the present invention, network management service **200** may also include communication service **208** depicted in **Figure 2** with dashed lines. Each of the respective elements of network management service **200**, and their corresponding communication protocols will be described more fully below. However, before describing these elements in further detail it should be noted that network management service **200** is an enabling technology. That is to say, network management service **200** enables a client to discover remote agents, communicate with remote agents, transfer files to and from remote computers, and remotely initiate local execution of applications on the client, independent of the particular type of operating system(s) operating on the client computer. Invocation of the services offered by the network management service may be accomplished in any number of approaches known in the art, e.g., application program interface(s) (API's).

Returning to the description of the elements of **Figure 2**, network management service **200** includes agent discovery service **202**. Agent discovery service **202** is the subject of the parent US Patent Application, identified above. In brief, agent discovery service **202** enables network management service **200** to discover and register remote agents, and allows local agents to be discovered and

remotely registered. The remote agents may be agents residing on remote clients or remote servers. In one embodiment of the present invention, agent discovery service **202** initiates the discovery process by broadcasting a packet (or datagram) of information on network **100** via network medium **120**. In the context of this implementation, the packet of information is referred to as a PING packet, i.e., the packet of information sent by agent discovery service **202** searching for remote agents. On behalf of remote agents disposed to discovery, discovery service of like kind, which may or may not be part of a network management agent, responds to the received PING packet with a similar packet of information, i.e., a PONG packet via network **100**.

In one embodiment of the present invention, lists of remote agents discovered are maintained. In one embodiment, for example, local applications instruct network management service **200** to discover remote agents, while in an alternate embodiment, network management service **200** autonomously updates the discovered list. In addition, agent discovery service **202** of network management service **200** responds, in accordance with user preferences for the network element in which it resides, to PING packets of remote agents.

Another element of the network management service **200** of **Figure 2** is the simple file transfer service **204**. In one implementation, files may be "pushed" (e.g., from client **102** to server **106**) or "pulled" (e.g., from server **106** to client **102**) using a pair of simple file transfer service **204** disposed in a client and a server, respectively. In an alternate implementation, simple file transfer service **204** unilaterally identifies and retrieves a file from a remote agent. In one embodiment, a listing (e.g., a directory) of the files available on the remote agent may be obtained by simple file transfer service **204**, in addition to the files themselves. In one embodiment, simple file transfer service **204** will depict a directory of available files in a UNICODE format, requiring local agents to interpret the UNICODE listing and translate the UNICODE directory into a local format. In one embodiment of the present invention, communication for the simple file transfer service **204** is performed on dynamic IPX sockets and UDP/IP ports, while in alternate embodiments, a fixed socket/port may be assigned.

The communication protocol employed by simple file transfer service **204** uses a request/reply datagram sequence to accomplish the file transfer. For example, in one implementation, simple file transfer service **204** requests include cancel, close, execute, list, create, read, shutdown and write operations. In accordance with this example protocol, each request will be responded to with a reply. For example, a create request will be responded to with a create reply.

In accordance with this example protocol, a create request is used to obtain a file handle for a new file to be created on the server. A cancel request is used to abort or cancel any operation in process. In one embodiment, the cancel request does not elicit a reply. The close request is used to prematurely close a write request. The list operation is used to obtain a directory listing of files. The directory listing may contain a single file name or it may contain an iterative list of file names satisfying wild-card characters. In one embodiment, the read request/reply datagrams contain a status field which indicates to the simple file transfer service when the end of file (EOF) is reached. Similarly, the write request is used to "push" a file from the client to the server. In one embodiment, the write request/reply datagrams contain a status field which indicates to the simple file transfer service that the end of file (EOF) has been reached.

The shutdown request is used to log off, power off, reboot, "kill" or shutdown a remote server. In particular, the shutdown request contains an attribute field which specifies which of the above operations are to be performed with the issuance of the shutdown request. In one embodiment, the server will reply with a failed shutdown request if there are other clients using it. However, by utilizing the "kill" option of the shutdown request, the client forces the server to terminate all clients (with ample notification to the clients that the server is going down) and proceeds with the request. In accordance with the example protocol, the execute request is used to remotely initiate local execution of a specified process. In one embodiment of the present invention, the request/reply sequences take the form of a communication packet, or datagram. One example of a file transfer datagram is depicted in **Figure 3**.

In accordance with the example file transfer datagram of **Figure 3**, file transfer datagram **300** is depicted comprising header **302**, version **304**, packet type **306**, dgram_size **308**, client_data **310**, server_data **312**, sequence field **314**, status **316**, file handle **318**, I_parm_1 **320**, I_parm_2 **322**, data length indicator **324** and data **326**. In this example file transfer datagram **300**, header **302** includes a header identifying the transport service utilized. In one embodiment, for example, header **302** is the base transport layer header. Version field **304** indicates the file transfer protocol version. That is, the version of the datagram is compared to the version of the application, wherein the datagram packet is converted to the appropriate version, if necessary.

The packet type field **306** of file transfer datagram **300** indicates the request or reply type for the current packet. For example, packet type **306** will indicate whether the current request is an open, close, cancel, etc. The dgram_size field **308** specifies the maximum packet size that can be accepted by the *sender* of the datagram (i.e., datagram **300**). Consequently, any packet returned to the sender should not exceed this size. In addition, those skilled in the art will appreciate that each of the different transport layers support a different maximum datagram size, which should not be exceeded. Consequently, dgram_size **308** contains the smaller of either the maximum datagram size of the sender, or the maximum datagram size of the base level transport layer employed. Client_data field **310** indicates identification data from the client side. The server application places the contents of client_data field **310** of a request packet into the client_data field **310** for the corresponding reply packet. The data of the client_data field **310** may be used, for example, to identify some instance data associated with the current packet session. Similar to client_data field **310**, is server_data field **312** which contains information with regard to the server. Sequence field **314** is used to identify repeated request and reply packets.

With continued reference to the file transfer datagram of **Figure 3**, status field **316** indicates the success or failure of a request. In one embodiment, for example, a zero indicates success, while a non-zero value represents some sort of

error. File handle **318** may be found in all replies and in all requests *except* for an open or a create request (wherein the reply will include the file handle). I_parm_1 **320** and I_parm_2 **322** are optional fields in the datagram and may, in one embodiment of the present invention, be used for creation data and file size in the open reply. Data length **324** indicates the byte-length of the data field. Data **326**, if present contains dynamic length data.

The contents of data field **326** depend on the packet type. For example, for a create packet type, data field **326** may contain the file specification, whereas for a read packet type, data field **326** may contain the read data. In the example implementation, all file transfer requests and replies use the same packet format. Not all fields are used by all requests or replies. In one embodiment, for example, when a field is not used in a particular request or reply, it is set to zero.

In accordance with this example implementation, **Figure 4** depicts a series of method steps wherein a file is pushed from a client to a server (e.g., client **102**, server **106**) through network management services. As depicted in **Figure 4**, the process begins with a create request sent by client **102** to server **106** using file transfer service of the respective network management service or equivalent, step **402**, wherein a temporary file is created on server **106** to store the pushed data. In one embodiment of the present invention, when the temporary upload file is created, a corresponding temporary file handle is created by simple file transfer service **204** of the server by which the temporary upload file is subsequently referred. Those skilled in the art will recognize that "a file handle is a [unique] 'token' (number) that the system uses in referring to an open file" (Computer Dictionary, Second Edition, published by Microsoft Press, page 165 (©1994)). That is to say, the file handle binds the upload file to a particular network address, wherein the network address includes the client application's dynamic socket/port. It should be appreciated, then, that there may be only one file handle per network address active at one particular time (unless multiple network transport services-sockets/ports are available, i.e., a multiprocessing multi-communication channel system).

In one embodiment, the temporary upload file is created by simple file transfer service **204** of network management service **200** of the server in a non-volatile storage device on the server. In an alternate embodiment, simple file transfer service **204** of network management service **200** of the server may allocate space in a volatile storage device for the temporary upload file.

Once the temporary upload file has been created, i.e., on the server (e.g., server **106**), the client opens the file which is to be uploaded and a write file transfer datagram is issued in step **404**, wherein data is written from the file resident on client **102** to the temporary upload file created on server **106**. The amount of data pushed with each write file transfer datagram is dependent upon the size of data field **326** of datagram **300**. In step **406**, a determination is made at client as to whether the end of the file to be pushed has been reached. If so, a close file transfer datagram is issued and the temporary upload file on the server is closed, step **408**. If it is determined in step **406** that the end of the file to be pushed has not yet been reached, however, the process loops back to step **404**, wherein another write file transfer datagram is issued and the next block of data is written from client **102** to the temporary upload file on server **106**. The looping process (e.g., steps **404** and **406**) continues until all of the data to be pushed has been written to the temporary upload file on server **106**, whereafter a close file transfer datagram is issued and the temporary upload file is closed, step **408**. Once the temporary upload file is closed, step **408**, server **106** renames the temporary upload file with the filename designated in the create request and any other file with the same name is removed, step **410**. If, however, a cancel request is issued prior to a close request, any previous file with the same name is preserved.

Similarly, in accordance with this example implementation, files may be pulled from a server to a client (e.g., from server **108** to client **104**) employing simple file transfer service **204** of network management service **200** or equivalent, as depicted in **Figure 5**. As illustrated, **Figure 5** depicts the method steps by which the simple file transfer service **204** of network management service **200** of a client "pulls" a file from server **108** to client **104**. The method begins wherein simple file transfer service **204** of the client issues an open file transfer datagram,

step **502**, and in response simple file transfer service **204** of the server opens the source file located on the server (e.g., server **108**). Concurrently, client **104** creates a temporary download file into which the data from the remote file will be read. Similar to the push process, client **104** creates a temporary download file, referenced via a file handle.

Once the remote file is opened, step **502**, a read file transfer datagram is issued, wherein a block of data is read from the remote file into the temporary download file, step **504**. The amount of data pulled in a single read file transfer datagram is limited only by the size allocated to data field **326** of file transfer datagram **300**. Subsequently, in step **506**, simple file transfer service **204** of the client determines whether the end of the remote file has been reached. If not, the method loops back to step **504**, and the next block of data is pulled. If, however, the entire file has been pulled, simple file transfer service **204** of the client issues a close file transfer datagram to close the remote file, step **508**. Once the close request has been issued, the file handle of the temporary download file is made permanent. If, however, a cancel request is issued prior to a close request, the remote file is closed and the temporary download file is removed (i.e., enabling client to reallocate memory allocated to the temporary download file).

In addition to its agent discovery service **202** and file transfer service **204** elements, network management service **200** of **Figure 2** includes remote execution service **206**. Remote execution service **206** of network management service **200** is used to initiate remote execution of an application, as well as remotely initiate local execution of an application. In one embodiment remote execution services **206** disposed on a client and a server cooperate to facilitate a server to respond to a client (or vice versa, or among clients, or among servers) to initiate execution of a file. In one implementation, a communication protocol of datagrams is employed by remote execution service **206** to facilitate remote initiation of local execution of an application, or initiate remote execution of an application. One example of a datagram employed by remote execution service **206** is illustrated in **Figure 6**.

Figure 6 illustrates an example of a datagram communication packet suitable for use by remote execution service **206**. As depicted in **Figure 6**, remote execution datagram **600** is shown comprising header **602**, version **604**, packet_type **606**, dgram_size **608**, client_data **610**, server_data **612**, sequence **614**, status **616**, data_length **618** and data field **620**. Of particular interest is data field **620**, wherein the executable filename and any command-line arguments (i.e., an argument list) are contained. In one embodiment of the present invention, each of the arguments within data_field **620** are zero-terminated, and the argument list ends after an empty string (also zero-terminated). Thus, in accordance with this example implementation, an example of the information contained in data_field **620** is depicted in example (1) below.

PBRUSH.EXE\0BITMAP.BMP\0\0 (1)

In an alternate embodiment, the data contained within data_field **620** may be terminated with a carriage-return/line-feed, terminated by a null-string (0), as depicted below in example (2).

PBRUSH.EXE
 BITMAP.BMP (2)
 0

The remote execution service **206**, in the role of facilitator, upon receipt of remote execution datagram **600** checks for the presence of the executable file described in data_field **620** and, if present, causes the file to be executed. Authorization services are incorporated into and are the responsibility of remote execution service **206**. The authorization protocol will vary depending on the operating environment. In one embodiment, the execution of the applications will not begin until the network management service **200** has been shutdown. In another embodiment, network management service **200** may cause itself to be transferred to and executed on a remote computer.

Continuing with the description of remote execution datagram **600**, header field **602** contains information related to the type of transport employed. In one embodiment, for example, header field **602** contains the transport layer header. Version field **604** contains the file transfer protocol version. The packet_type field **606** of remote execution datagram **600** contains the request or reply type for this packet. The dgram_size field **608** contains information as to the maximum packet size that can be accepted by the sender of remote execution datagram **600**. Consequently, any packet returned to the sender of remote execution datagram **600** (i.e., a reply) should not exceed this size. As was the case for file transfer datagram **300**, dgram_size **608** contains the smaller of either the maximum datagram size of the sender, or the maximum datagram size of the base level transport layer employed.

In addition, remote execution datagram **600** includes client_data field **610**. In one embodiment, for example, client_data field **610** is a four-byte field containing data from the client side. The remote execution service places the contents of client_data field **610** of a request packet into the client_data field **610** for the corresponding reply packet. The data of the client_data field **610** may be used, for example, to identify some instance data associated with the current packet session. Similar to client_data field **610**, is server_data field **612** which contains information with regard to the server. Sequence field **614** is used to identify repeated request and reply packets. Status field **616** of remote execution datagram **600** indicates the success or failure of a request. The data_length field **618** indicates to the recipient of remote execution datagram **600** the length of the data field.

In addition to the above described elements of network management service **200**, i.e., agent discovery service **202**, simple file transfer service **204** and remote execution service **206**, network management service **200** may beneficially include communication service **208**. Network management service **190** employs communication service **208** to "translate" the information to/from the transport layer service.

In one embodiment, communication service **208** allows network management service **200** to function regardless of the underlying network transport protocol by abstracting the differences of the supported transport protocols (TCP/IP, IPX/SPX, etc.) into a set of common-denominator functions, and by establishing well-known port or socket addresses for communication service communications. For example, in one embodiment, communication service **208** establishes "listening addresses" for all of the supported transport protocols (identified above) and uses the agent discovery service **202** discovery protocol to make these listening addresses available to other instances of communication service **208** located throughout the network. Having established listening addresses for each supported transport protocol, and having made those addresses discoverable to communication service **208** of remote network management services (i.e., network management service **200**), the network management service **200** of the server may then proceed to perform communications over the network, via communication service **208** without regard to any particular transport protocol supported by a particular client. In particular, communication service **208** on a server (e.g., server **108**) knows which protocol(s) is(are) supported by communication service **208** on the client (e.g., client **104**), and at which listening addresses those protocols are typically received.

Given the descriptions and example implementations above, one skilled in the art will appreciate that the innovative features of network management service **200** may be implemented in a number of alternate embodiments. In one embodiment, for example, network management service **200** may take the form of a plurality of software instructions stored in a machine readable format and executed by a computer. In an alternate embodiment, network management service **200** may be embedded in an Application Specific Integrated Circuit within a computer.

Having described the functional elements and protocols employed by network management service **200** in **Figures 2-6** above, **Figures 7-9** are provided as an example, and not limitation, of an example application of the innovative features of the network management service **200**. In **Figure 7**, a flow chart illustrating one example of a method for configuring an unconfigured client

computer. For ease of understanding, the example application of **Figures 7-9** will be described in the context of the elements of network **100**. Accordingly, in the context of the example implementation, a network management application (e.g., application **160**) executing on a server (e.g., server **108**) through network management service **200** detects an unconfigured client computer (e.g., client **105**) and, in accordance with the innovative features enabled by the network management service (e.g., network management service **192**), configures the client for operation within network **100**.

Before describing the method of **Figure 7** in detail, it may be helpful to review an example high-level architecture of an unconfigured client. **Figure 8** illustrates a block diagram of the high-level architecture of unconfigured client computer **800**. The use of the term "unconfigured" may be a bit of a misnomer insofar as there is a rudimentary level of functionality that is assumed when a computer is shipped from a computer manufacturer. As depicted in the example architecture of **Figure 8**, "unconfigured" client computer **800** includes hardware **802**, hardware configuration data **804**, basic input/output system (BIOS) **806**, BIOS configuration data **808** and a rudimentary set of network boot instructions stored in non-volatile memory (e.g., a boot PROM) **810**. In one embodiment, client computer **800** is client **105**. Hardware **802** includes at least one processor, a memory subsystem, an input/output device, and a communications subsystem. In one embodiment, hardware **802** may also include such items as a mass storage device, a display, peripherals, and the like. Hardware configuration data **804** includes information necessary to interface elements of hardware **802**. BIOS **806** provides basic input/output services. In one embodiment, BIOS **806** includes desktop management interface (DMI) services including special network manageability services, e.g., in accordance with Desktop Management BIOS Specification, version 2.0, dated February 23, 1996. BIOS configuration data **808** includes configuration data for the hardware/I/O system. Boot instructions **810** provide a set of instructions executed at start-up which provide a nominal level of functionality to the computer. Boot instructions **810** are stored in a non-volatile memory such as a programmable read-only memory (PROM), and initiate execution of a rudimentary "operating system" (OS). In one embodiment, the rudimentary

"OS" provides the computer with a rudimentary level of memory management, communication and file transfer capability to computer **800**. (Thus the definition of unconfigured includes a rudimentary operating system. I believe that it is the requirement of a rudimentary operating system that will distinguish this case from the new ICG disclosures).

Returning to the example method of **Figure 7**, the method of configuring an unconfigured client begins with step **702**, wherein server **108** determines that client **105** is not executing an operating system. The means by which server **108** determines that client **105** does not have an operating system depends upon the configuration of client **105**. For example, in one embodiment wherein client **105** is configured with network management service **200**, the agent discovery service broadcasts PING datagrams looking for servers that can fully configure client **105**. In an alternate embodiment, a network management service resident on server **108** broadcasts PING datagrams searching for unconfigured network clients, and client **105** responds to the PING datagram with an indication identifying client **105** as an unconfigured network client.

For the illustrated example, once it has been determined by management application **160** that client **105** is not populated with an operating system, management application **160** next determines whether client **105** is populated with a network management service. As described above, in one embodiment, agent discovery service **202** of network management service **192** issues a PING datagram on network medium **120** via network transport service **180**, and awaits a reply (i.e., a PONG datagram). If, in step **704**, it is determined that client **105** does not have a network management service, network management service **192** downloads a copy of network management service to client **105** via the rudimentary OS, in accordance with, for example, the method steps illustrated in **Figure 5**, step **708**. Once the download of a network management service has been completed in step **708**, its execution is initiated, step **710**.

Once a network management service has been downloaded to and executed on client **105** from network management service **192** in steps **706** and **708**, or if

in step **704** it was determined that client **105** was already enabled with a network management service, management application **160** determines the operating system requirements for client **105**, step **710**. In one embodiment, for example, this determination is made by ascertaining the type of processor resident in client **105**. Having determined the operating system requirements of client **105**, management application **160**, via simple file transfer service **204** of network management service **192** downloads an appropriate operating system from server **106** to client **105**, step **712**. Once the download of the appropriate operating system has been completed in step **712**, remote execution service **206** of network management service **192** of server **106** and the remote execution service of the newly downloaded network management service on client **105** are employed by management application **160** to remotely initiate execution of the newly downloaded operating system on the client, step **714**. In one embodiment, for example, the remote execution service of network management service **192** of server **106** issues a remote execution datagram to the remote execution service of the downloaded network management service resident on client **105**, identifying the AUTOEXEC.BAT file, with appropriate command line entries, thereby remotely initiating local execution of the operating system on client **105**.

In addition to the download of a new, or an upgrade of an existing operating system, server **106** may utilize network management service **192** and the newly downloaded network management service on client **105** to download additional applications or agents to client **105**, step **716**. **Figure 9** illustrates a block diagram of the method steps depicted in **Figure 7** from a network perspective. In particular, **Figure 9** illustrates server **106** downloading a network management service to client **105** and subsequently utilizing the downloaded network management service to facilitate a network management agent to configure client **105** with an operating system and other applications/agents.

Another example of the innovative features enabled by the introduction of network management service **200** into a network is illustrated in **Figure 10**. In particular, **Figure 10** illustrates the method steps wherein a server configured with network management service **200** facilitates remote initiation (i.e., "power up") of a

network management service-enabled client computer that is in a power-off or "sleep" state (e.g., a low power state) to perform network management operations, and subsequently returns the client to its power state prior to the network management session. For ease of explanation, the method steps of **Figure 10** will be developed in the context of the network elements of **Figure 1**.

The method begins, step **1002**, with a network management agent identifying a client (e.g., client **102**) that is the target of the management operation (i.e., the remote power-up operation) of the server (e.g., server **108**). There are a number of methods by which the target client may be identified. In one embodiment, for example, network management agent **162** establishes a list of all network clients which are operating under a prior version of a particular operating system, which includes client **102** for this example. In accordance with the teachings of the present invention, rather than interrupting the computer services to a user of client **102** by immediately upgrading the clients operating system, network management agent **162** may make a log entry of the fact that the identified client needs defined network maintenance. Subsequently, when network management agent **162** "senses" that client **102** has been powered-off, network management agent **162** waits for a convenient maintenance period to perform such maintenance (e.g., after normal working hours).

Having identified the target client in step **1002**, network management service **192** of the server is called upon to determine if client **102** is configured with a network management service. In one embodiment, network management service **192** sends a PING datagram to discover if client **102** is configured with a network management service, in accordance with the teachings above. If network management service **192** determines that client **102** is not populated with a network management service, network management service **192** populates client **102** with a network management service. In particular, with client powered-up, network management service **192** of the server pushes (i.e., downloads) a network management service from server **108** to client **102**, step **1006**, and remotely initiates local execution of the pushed network management service, step **1008**, in accordance with the teachings of **Figure 5**.

If, in step **1004**, it is determined that client **102** is populated with a network management service (e.g., network management service **150**), network management agent **162**, through network management service **150**, retrieves the last power state of client **102**. In step **1010**, network management agent **162** determines if the power state of client **102** is satisfactory to perform the desired operation, step **1012**. If not, network management agent **162** issues a power state command through network management service **192** to network management service **150** to place client **102** in the necessary power state, step **1014**.

Having issued the power state command in step **1014**, or if in step **1012** it is determined that client **102** is in the proper power state to perform the desired operation, network management agent **162** performs the desired management function in step **1016**. In accordance with the present example implementation, network management service determines that client is in a powered-down state, steps **1010**, **1012**, and issues the necessary power state command to enable at least a subset of the system components comprising client **102** (e.g., the computer, but not the monitor, printer, scanner, etc.), step **1014**. Once client **102** has booted up, albeit running an old version of the OS, network management service initiates an OS upgrade, step **1016**.

Having completed the desired network management operation in step **1016**, network management agent **162** issues a power state command to network management service **150** through network management service **192** to place client **102** in the power state prior to the network management session, step **1018**.

Those skilled in the art will appreciate that the innovative network management service provides a heightened level of network manageability and interoperability. As described above, the network management service is platform independent; that is, it will work in a myriad of computer processing environments. Insofar as the network management service **200** operates independently of any particular computer operating system, the introduction of a network management service **200** into a network (e.g., network **100**) allows a network manager in a

central location to not only monitor network statistics, but to interrogate and remotely manipulate remote clients. As alluded to earlier, network management service **200** is an enabling technology providing a new generation of network management applications with interoperable access to the most fundamental processes of the computer system.

Thus, alternative embodiments for a method and apparatus facilitating the management of networked devices have been disclosed. While the method and apparatus of the present invention has been described in terms of the above illustrated embodiments, those skilled in the art will recognize that the invention is not limited to the embodiments described. For example, one skilled in the art will appreciate from the above description and example implementations that network management service **200** may be beneficially employed to perform a number of network functions heretofore unavailable in prior art network management tools. In addition, it has been shown that it is unnecessary for each of the computing elements within network **100** to incorporate network management service **200**, for so long as it is available within the network, it may be downloaded and executed on an as-needed basis. Thus, those skilled in the art will appreciate that the present invention can be practiced with modification and alteration within the spirit and scope of the appended claims. Accordingly, the descriptions thereof are to be regarded as illustrative instead of restrictive on the present invention.

CLAIMS

What is claimed is:

1. A network management service comprising:
an agent discovery service, including a discovery function for broadcasting agent discovery messages to discover remote agents, and a registration function for registering discovered remote agents; and
a file transfer service, operative to send information to and receive information from remote systems.
2. The network management service of claim 1, wherein the file transfer service uses a protocol to transfer files between network devices, independent of any particular operating system residing on the network devices.
3. The network management service of claim 1, wherein the information is an executable application.
4. The network management service of claim 1, wherein the information is the network management service itself.
5. The network management service of claim 1, wherein the information is an operating system.
6. The network management service of claim 1, further comprising a remote execution service through which the network management service can initiate execution of an application on discovered agents, and through which remote agents can initiate execution of applications.
7. The network management service of claim 6, wherein the remote execution service uses a protocol to remotely initiate execution of files on network devices, independent of any particular operating system implemented on the network devices.
8. The network management service of claim 1, further comprising a communication service for translating between different network transport services.
9. A network management service comprising:
an agent discovery service, including a discovery function for broadcasting agent discovery messages to discover remote agents, and a registration function for registering discovered remote agents; and

a remote execution service through which the network management service can initiate execution of an application on discovered agents, and through which remote agents can initiate execution of applications.

10. The network management service of claim 9, wherein the remote execution service uses a protocol to remotely initiate execution of files on network devices, independent of any particular operating system implemented on the network devices.

11. The network management agent of claim 9, further comprising a file transfer service, operative to send information to and receive information from remote systems.

12. The network management service of claim 11, wherein the information is an executable application.

13. The network management service of claim 11, wherein the information is the network management service itself.

14. The network management service of claim 11, wherein the information is an operating system.

15. The network management service of claim 1, further comprising a communication service for translating between different network transport services.

16. A network management service comprising:

a file transfer service, operative to send information to and receive information from remote systems; and

a remote execution service through which execution of discovered agents can be initiated, and through which remote agents can initiate local execution of applications.

17. The network management service of claim 16, wherein the file transfer service uses a protocol to transfer files between network devices, independent of any particular operating system residing on the network devices.

18. The network management service of claim 16, wherein the information is an executable application

19. The network management service of claim 16, wherein the information is the network management service itself.

20. The network management service of claim 16, wherein the information is an operating system.

21. The network management service of claim 16, wherein the remote execution service uses a protocol to remotely initiate execution of files on network devices, independent of any particular operating system implemented on the network devices.

22. The network management service of claim 16, further comprising a communication service for translating between different network transport services.

23. A computer system including an operating system, the computer system further comprising:

an agent discovery service, including a discovery function for broadcasting agent discovery messages to remote agents, and a registration function for registering discovered remote agents; and

a file transfer service, operative to send information to and receive information from remote systems.

24. The computer system of claim 23, wherein the file transfer service uses a protocol to transfer information to and from remote computers independent of any particular operating system residing on the remote computers.

25. The computer system of claim 23, further comprising a remote execution service through which execution of discovered agents can be initiated, and through which remote agents can initiate local execution of applications

26. The computer system of claim 25, wherein the remote execution service uses a protocol to remotely initiate execution of applications on remote computers, independent of any particular operating system residing on the remote computers.

27. The computer system of claim 23, further comprising a communication service for translating between different network transport services.

28. A computer comprising:

a storage medium having stored therein a plurality of programming instructions for implementing a network management service including an agent discovery service for discovering remote agents within a network of computer systems and for registering discovered remote agents, and a simple file transfer service for transferring information to and receiving information from remote systems; and

an execution unit, coupled to the storage medium, for executing the programming instructions.

29. The computer of claim 28, wherein the network management service further includes a communication service for translating between different network transport services.

30. A computer configured to enable advanced network management functions within a computer network, the computer comprising:

a storage medium having stored therein a plurality of programming instructions for implementing a network management service including a simple file transfer service for transferring information to and receiving information from remote systems, and a remote execution service through which execution of discovered agents can be initiated and through which remote agents can initiate local execution of applications; and

an execution unit, coupled to the storage medium, for executing the programming instructions.

31. The computer of claim 30, wherein the network management service further includes a communication service for translating between different network transport services.

32. A method for implementing advanced network management functions in a computer network, the method comprising:

(a) discovering remote agents operative on the network, independent of any particular operating system residing on network devices;

(b) enabling a file transfer service for transferring files between network devices, independent of any particular operating system residing on the network devices; and

(c) providing a remote execution service for initiating execution of an application on remote network devices, independent of any particular operating system residing on the remote network devices.

33. The method of claim 32, further comprising:

(d) utilizing a network transport service to translate information to/from a network management protocol; and

(e) providing a communication service for communicating with remote network devices unendowed with the advanced network management functions independent of any particular operating system residing on the network devices.

34. A computer system comprising:

a plurality of processors cooperatively implementing an operating system (OS)

a network input/output interface, through which the plurality of processors communicate with remote network devices through the OS; and

a network management service, in communication with at least a subset of the plurality of processors, the network management service including

an agent discovery unit, coupled to the network input/output interface of the computer system, operative to broadcast discovery packets for discovering and registering remote agents, a file transfer unit, coupled to the network input/output interface of the computer system, operative to send/receive files from remote network devices, independent of any particular operating system residing on the remote network devices, and a remote execution unit, coupled to the network input/output interface of the computer system, operative to initiate execution of applications on remote network devices, independent of any particular operating system residing on the remote network devices.

35. The computer system of claim 34, wherein the network management service further includes

a communication service, in communication with the agent discovery unit, the file transfer unit, and the remote execution unit, and operative to support communication with remote network devices regardless of the transport protocol utilized by the remote network devices.

36. A machine readable medium having stored therein a plurality of machine executable instructions for implementing an advanced network management service including an agent discovery service for discovering remote agents within the network of computer systems and for registering discovered remote agents, a simple file transfer service for transferring files to and receiving files from remote computers, and a remote execution service, through which the server can initiate execution of applications on remote computers independent of any particular operating system residing on the remote agents.

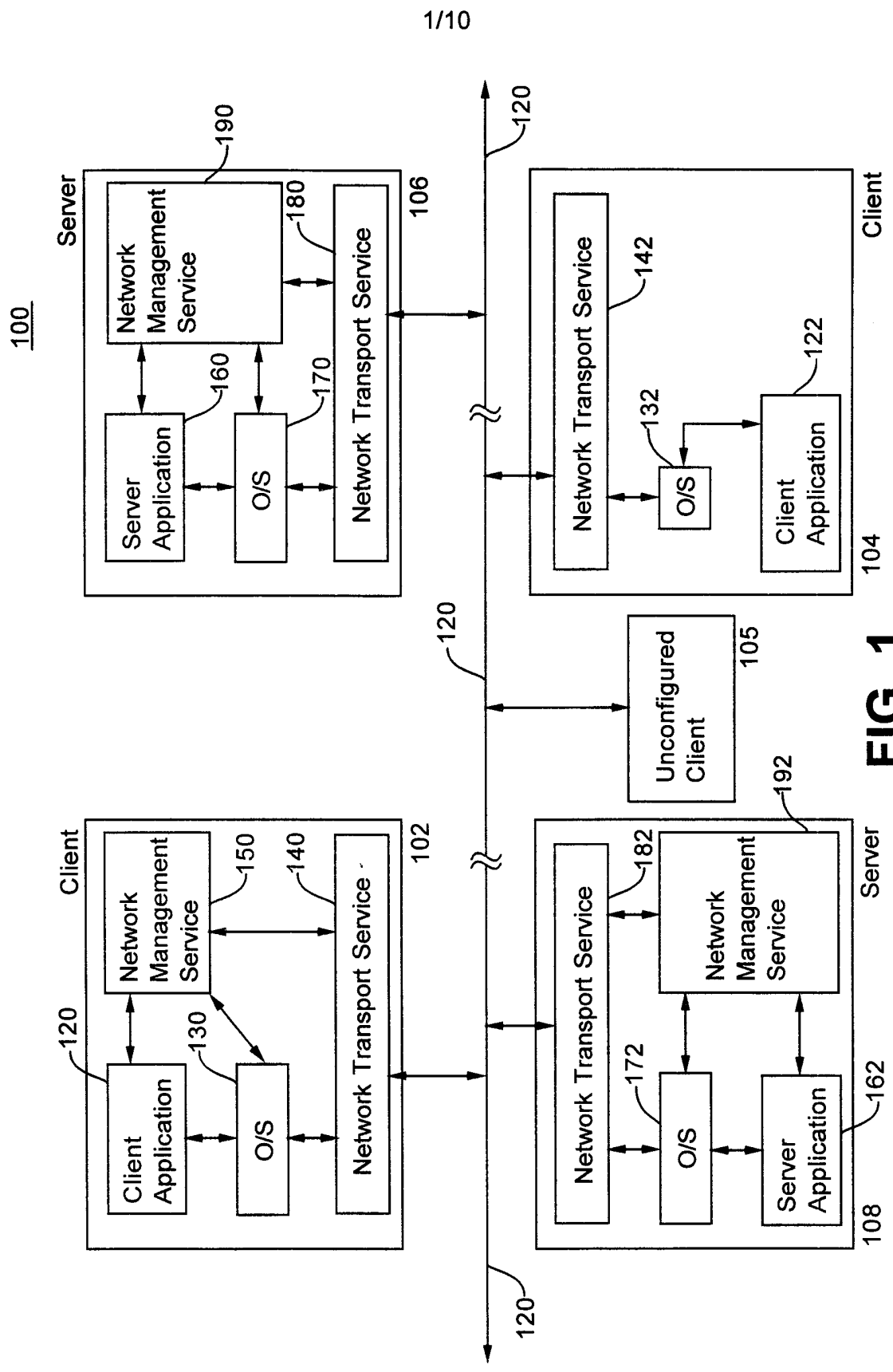

FIG. 1

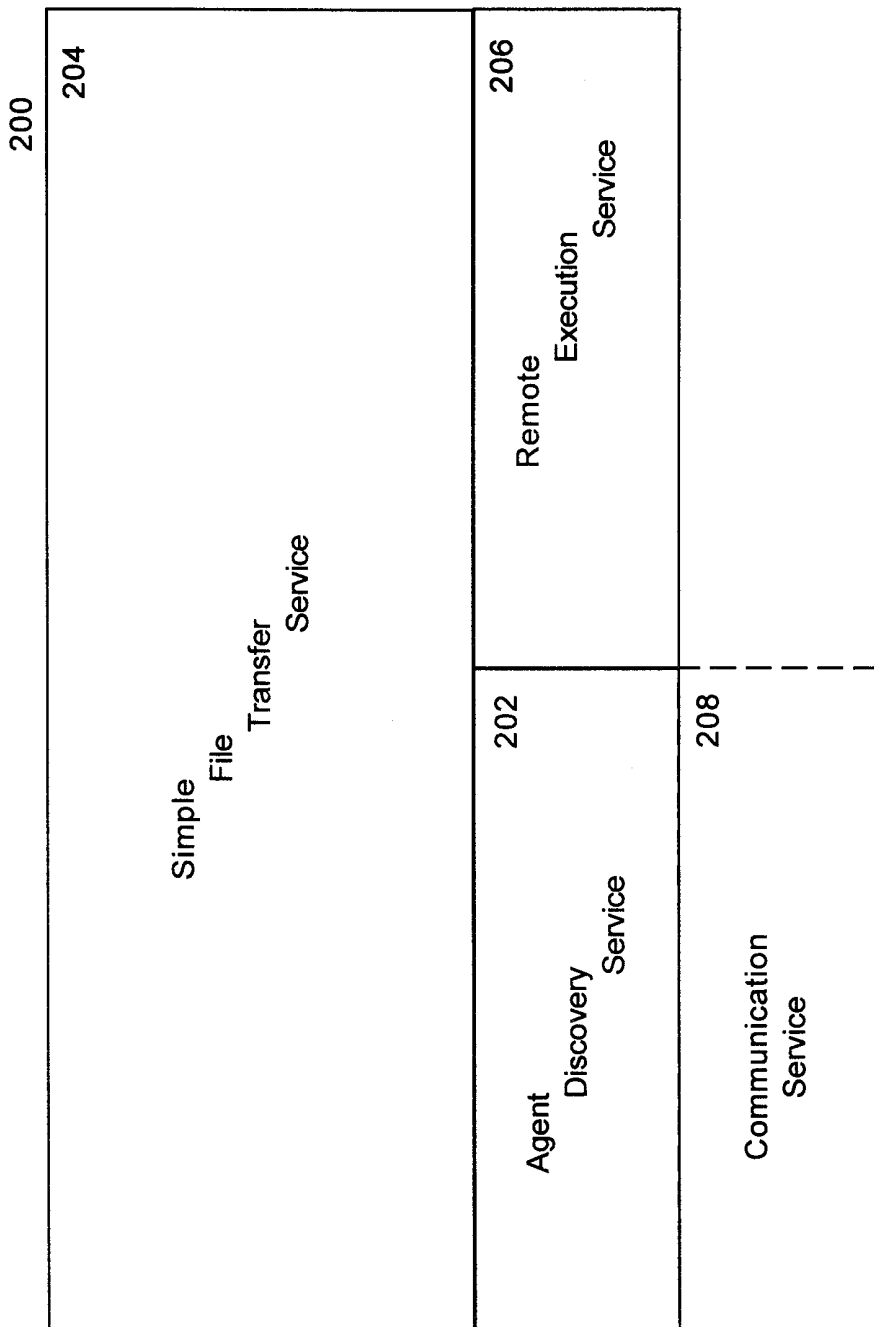

FIG. 2

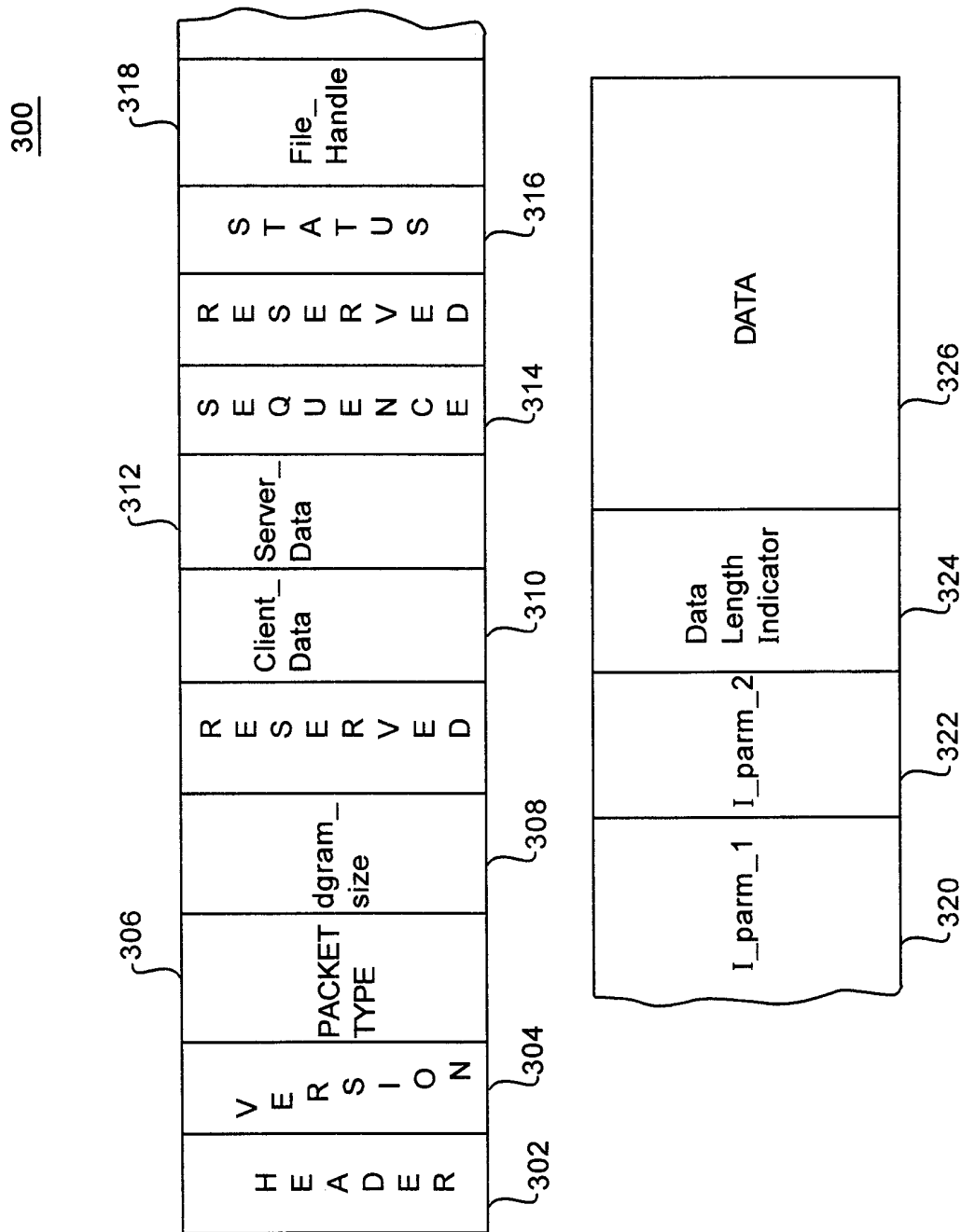

FIG. 3

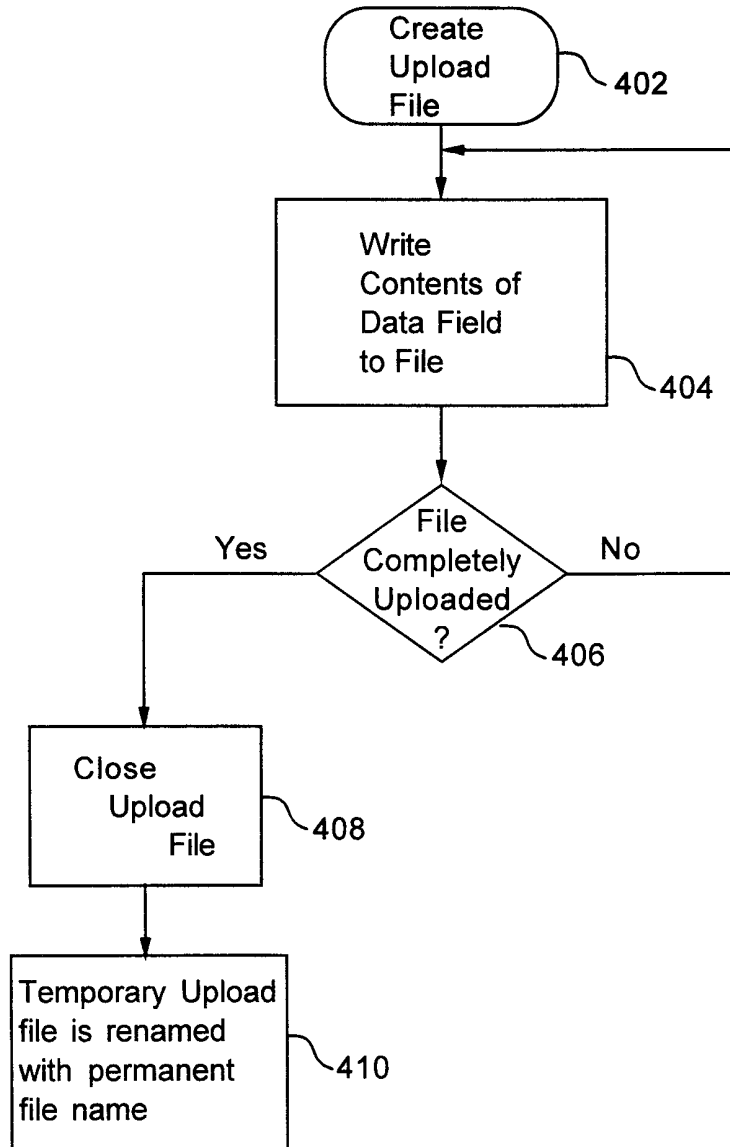

FIG. 4

5/10

500

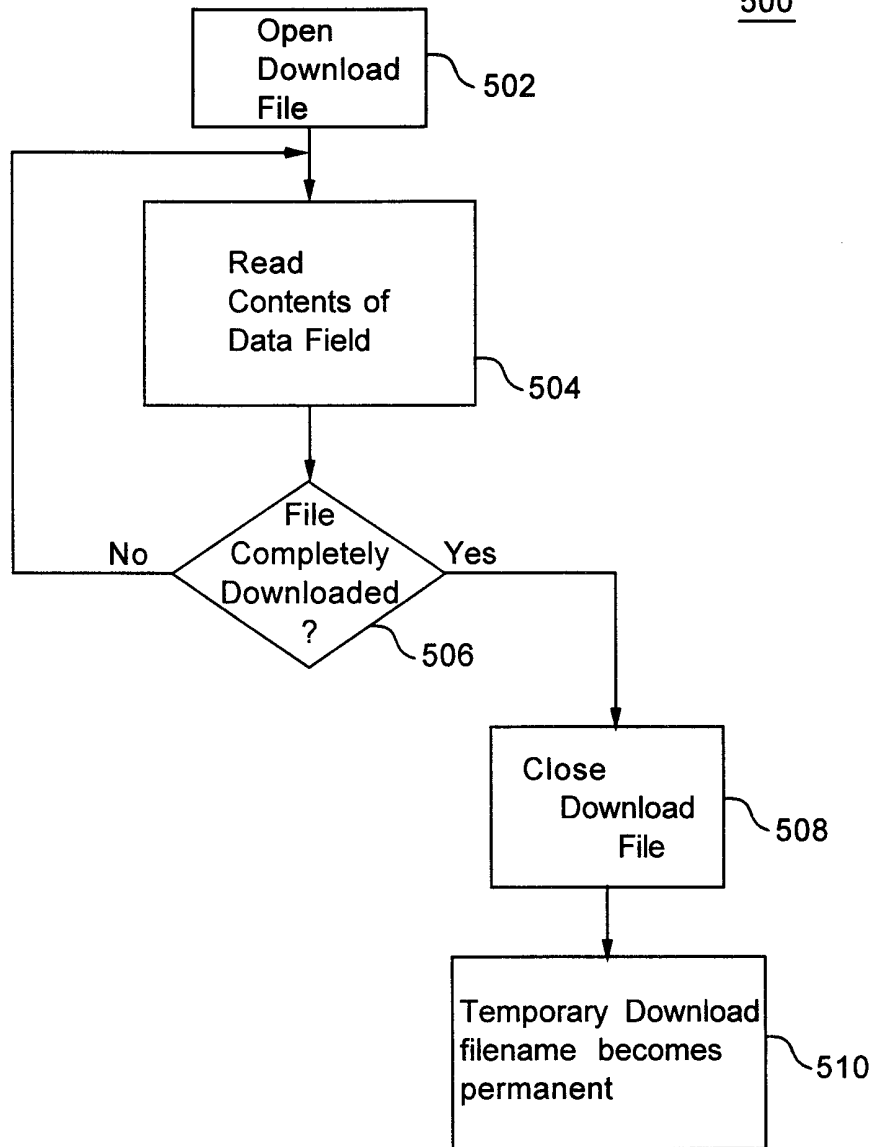

FIG. 5

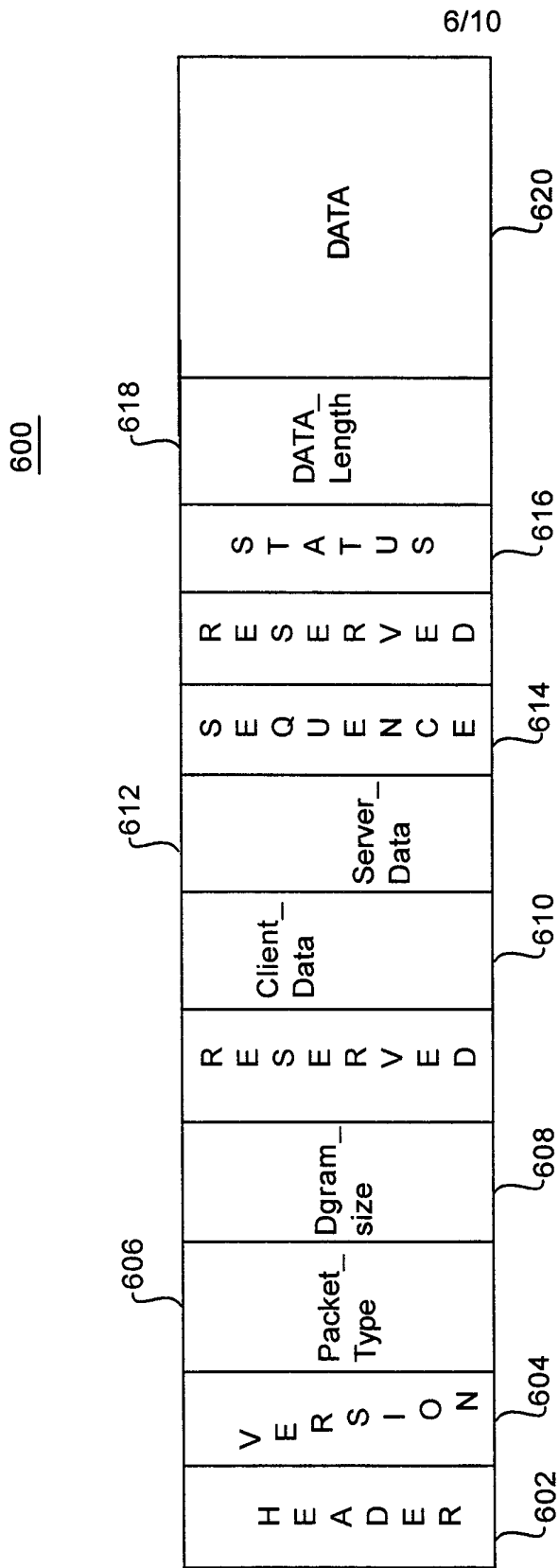

FIG. 6

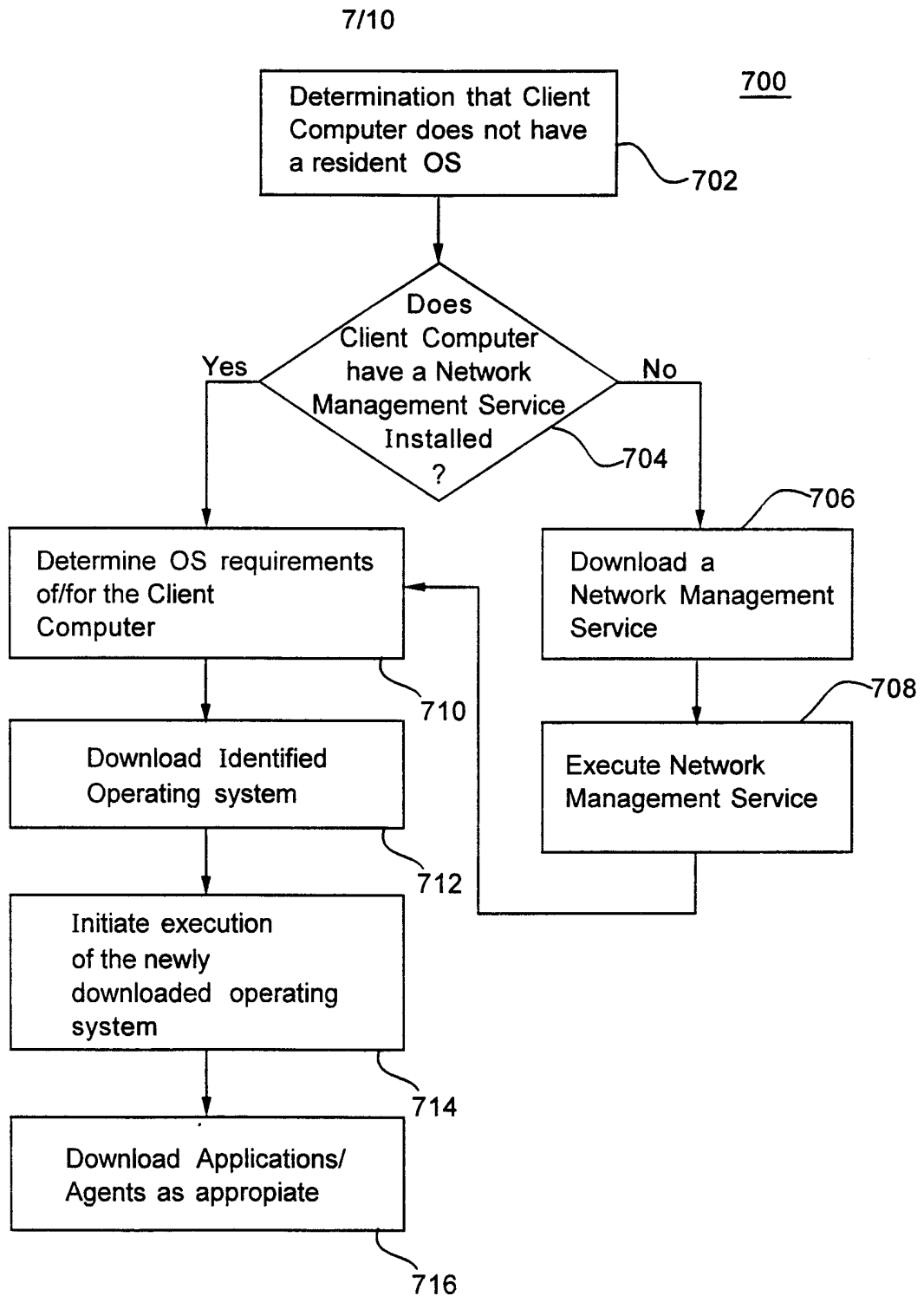

FIG. 7

800

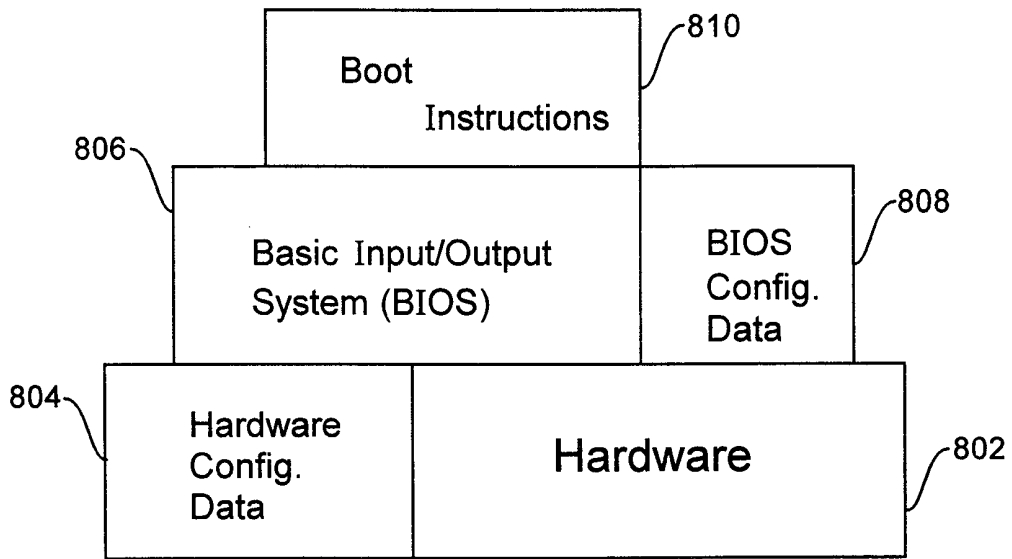

FIG. 8

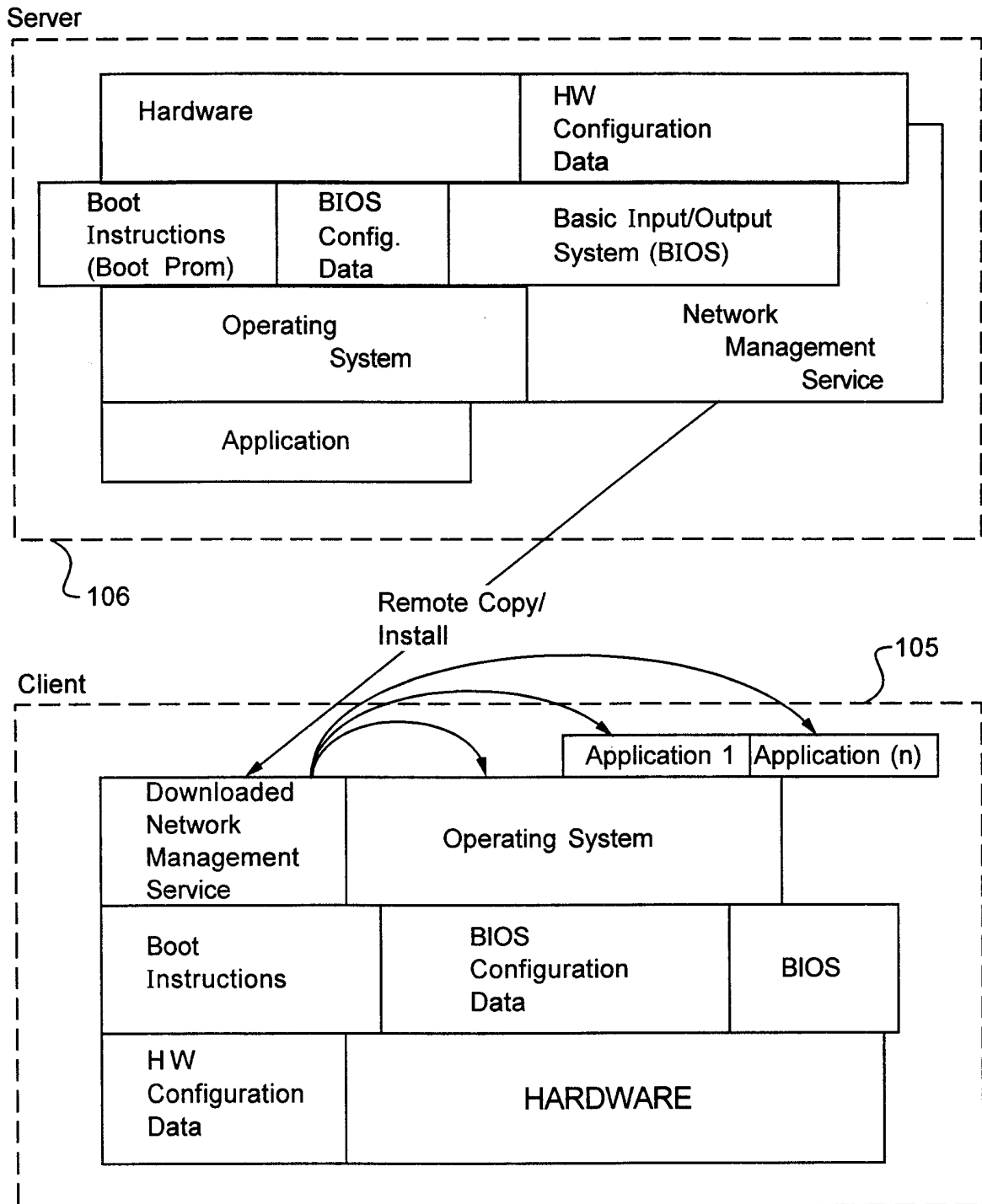

FIG. 9

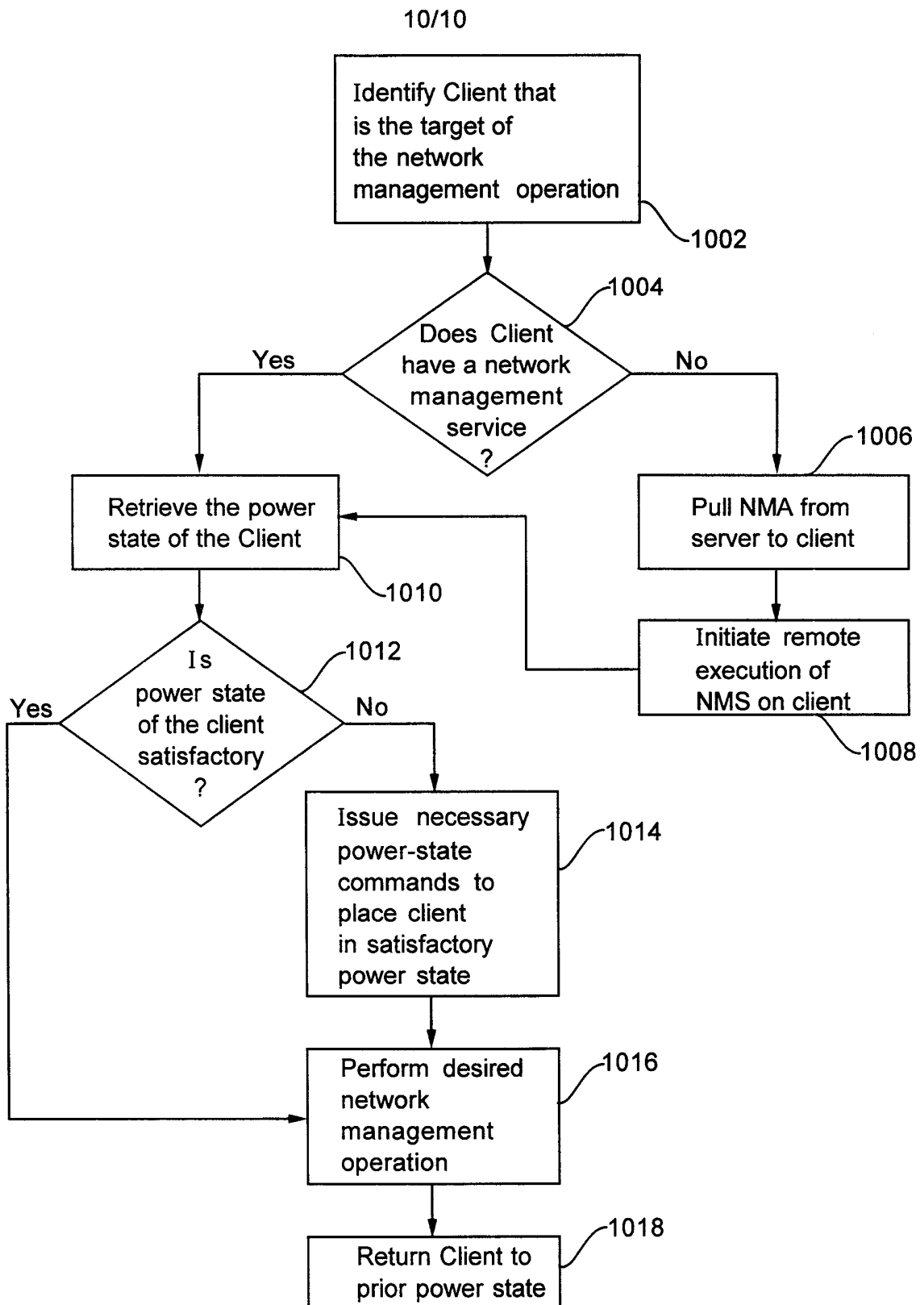

FIG. 10

INTERNATIONAL SEARCH REPORT

International application No.
PCT/US98/12388

A. CLASSIFICATION OF SUBJECT MATTER
 IPC(6) : G06F 11/00
 US CL : 395/200.53
 According to International Patent Classification (IPC) or to both national classification and IPC

B. FIELDS SEARCHED
 Minimum documentation searched (classification system followed by classification symbols)
 U.S. : Please See Extra Sheet.

Documentation searched other than minimum documentation to the extent that such documents are included in the fields searched

Electronic data base consulted during the international search (name of data base and, where practicable, search terms used)
 APS, WWW
 Search terms NETPC, TFTP, DHCP, RPC

C. DOCUMENTS CONSIDERED TO BE RELEVANT

Category*	Citation of document, with indication, where appropriate, of the relevant passages	Relevant to claim No.
X -- Y	CROFT ET AL. Bootstrap Protocol (BOOTP) , RFC 951, Section 2, 7.5, page 10-11, Appendix A, September 1985.	1-7, 16, 21, 23-26, 28-34 ----- 8-15, 17-20, 22
Y	Oxford Dictionary of Computing, 4th Ed. Oxford University Press, pages 446-447, 1996	8,15
Y	Sun Microsystems Remote Procedure Call Protocol Specification, RFC 1050, Section 2, Appendix A. April 1988.	9-14, 17-20, 22

Further documents are listed in the continuation of Box C. See patent family annex.

- | | |
|-------------------------------------------------------------------------------------------------------------------------------------------------------------------------|--------------------------------------------------------------------------------------------------------------------------------------------------------------------------------------------------------------------------------------------------|
| * Special categories of cited documents: | *T* later document published after the international filing date or priority date and not in conflict with the application but cited to understand the principle or theory underlying the invention |
| *A* document defining the general state of the art which is not considered to be of particular relevance | *X* document of particular relevance; the claimed invention cannot be considered novel or cannot be considered to involve an inventive step when the document is taken alone |
| *E* earlier document published on or after the international filing date | *Y* document of particular relevance; the claimed invention cannot be considered to involve an inventive step when the document is combined with one or more other such documents, such combination being obvious to a person skilled in the art |
| *L* document which may throw doubts on priority claim(s) or which is cited to establish the publication date of another citation or other special reason (as specified) | * & * document member of the same patent family |
| *O* document referring to an oral disclosure, use, exhibition or other means | |
| *P* document published prior to the international filing date but later than the priority date claimed | |

Date of the actual completion of the international search 28 AUGUST 1998	Date of mailing of the international search report 24 DEC 1998
-----------------------------------------------------------------------------	--------------------------------------------------------------------------

Name and mailing address of the ISA/US Commissioner of Patents and Trademarks Box PCT Washington, D.C. 20231 Facsimile No. (703) 305-3230	Authorized officer Glenton Burgess <i>Joni Hill</i> Telephone No. (703) 308-4792
-------------------------------------------------------------------------------------------------------------------------------------------------------	----------------------------------------------------------------------------------------

INTERNATIONAL SEARCH REPORT

International application No.
PCT/US98/12388

C (Continuation). DOCUMENTS CONSIDERED TO BE RELEVANT

Category*	Citation of document, with indication, where appropriate, of the relevant passages	Relevant to claim No.
X	NetPC System Design Guidelines, Compaq Computer Corporation, Dell Computer Corporation, Hewlett Packard Company, Intel Corporation, Microsoft Corporation, pg. 11, version 0.9, 10 March 1997.	1-34

INTERNATIONAL SEARCH REPORT

International application No.
PCT/US98/12388

B. FIELDS SEARCHED

Minimum documentation searched

Classification System: U.S.

395/181, 182.21, 182.22, 182.08, 182.06, 182.07, 200.32, 200.5, 200.53