



(51) International Patent Classification:

A61F 5/56 (2006.01)

(21) International Application Number:

PCT/IB2019/054558

(22) International Filing Date:

31 May 2019 (31.05.2019)

(25) Filing Language:

Dutch

(26) Publication Language:

English

(30) Priority Data:

BE 2018/0069 30 May 2018 (30.05.2018) BE

(71) Applicant: TITA-LINK B.V.B.A. [BE/BE]; Molenberglaan 27, 3080 Tervuren (BE).

(72) Inventor: DE CLERCK, Hugo; Molenberglaan 27, 3080 Tervuren (BE).

(74) Agent: CALLEWAERT, Koen; Bureau Callewaert B.V.B.A., Brusselsesteenweg 108, 3090 Overijse (BE).

(81) Designated States (unless otherwise indicated, for every kind of national protection available): AE, AG, AL, AM,

AO, AT, AU, AZ, BA, BB, BG, BH, BN, BR, BW, BY, BZ, CA, CH, CL, CN, CO, CR, CU, CZ, DE, DJ, DK, DM, DO, DZ, EC, EE, EG, ES, FI, GB, GD, GE, GH, GM, GT, HN, HR, HU, ID, IL, IN, IR, IS, JO, JP, KE, KG, KH, KN, KP, KR, KW, KZ, LA, LC, LK, LR, LS, LU, LY, MA, MD, ME, MG, MK, MN, MW, MX, MY, MZ, NA, NG, NI, NO, NZ, OM, PA, PE, PG, PH, PL, PT, QA, RO, RS, RU, RW, SA, SC, SD, SE, SG, SK, SL, SM, ST, SV, SY, TH, TJ, TM, TN, TR, TT, TZ, UA, UG, US, UZ, VC, VN, ZA, ZM, ZW.

(84) Designated States (unless otherwise indicated, for every kind of regional protection available): ARIPO (BW, GH, GM, KE, LR, LS, MW, MZ, NA, RW, SD, SL, ST, SZ, TZ, UG, ZM, ZW), Eurasian (AM, AZ, BY, KG, KZ, RU, TJ, TM), European (AL, AT, BE, BG, CH, CY, CZ, DE, DK, EE, ES, FI, FR, GB, GR, HR, HU, IE, IS, IT, LT, LU, LV, MC, MK, MT, NL, NO, PL, PT, RO, RS, SE, SI, SK, SM, TR), OAPI (BF, BJ, CF, CG, CI, CM, GA, GN, GQ, GW, KM, ML, MR, NE, SN, TD, TG).

(54) Title: JAW DISPLACEMENT SYSTEM AND METHOD FOR MANUFACTURING SUCH A SYSTEM FOR THE TREATMENT OF SLEEP APNOEA AND/OR SNORING

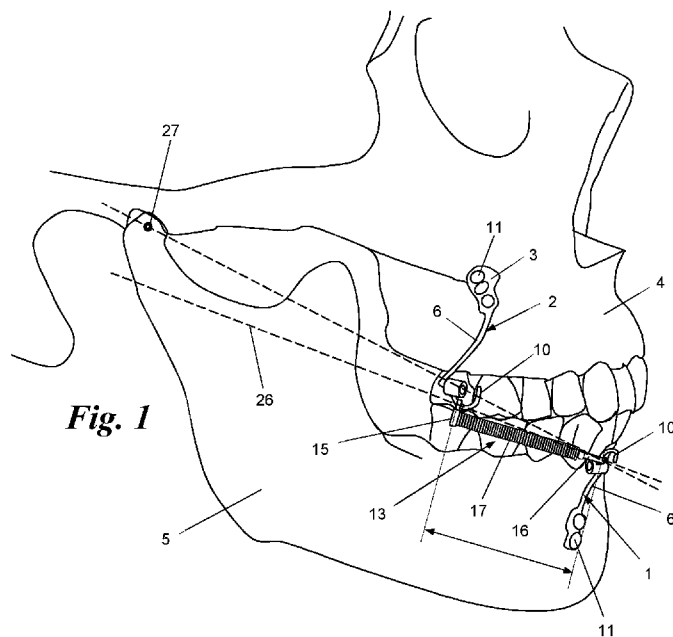

Fig. 1

(57) Abstract: The invention concerns a jaw displacement system for the treatment of sleep apnoea and/or snoring and a method for manufacturing this system. According to the invention, bone anchors (1,2) are provided on the upper and lower jaw (4,5) of a patient, between which a detachable jaw displacer (13) is mounted.



Published:

- *with international search report (Art. 21(3))*
- *before the expiration of the time limit for amending the claims and to be republished in the event of receipt of amendments (Rule 48.2(h))*
- *in black and white; the international application as filed contained color or greyscale and is available for download from PATENTSCOPE*

JAW DISPLACEMENT SYSTEM AND METHOD FOR MANUFACTURING SUCH A SYSTEM
FOR THE TREATMENT OF SLEEP APNOEA AND/OR SNORING.

5 The invention concerns a jaw displacement system for the
treatment of sleep apnoea and/or snoring. This system includes a first and a second
bone anchor, where each bone anchor has a fixation plate that is provided to attach
the bone anchor to the bone of an upper or lower jaw. The fixation plate is
connected to a connecting element that leads to a mounting device. When the bone
10 anchor is attached to the bone of the upper or lower jaw, the connecting element
should stretch through the gum so that the mounting device is located in the oral
cavity.

 This jaw displacement system also includes a jaw displacer with a
rod and a rod guide. The rod has a first end of the jaw displacer, while the rod guide
15 contains a second end of the jaw displacer opposite to the latter. The rod can be
moved according to the longitudinal direction of the rod guide and can be detached
in relation to the latter.

 The jaw displacement system further has coupling means which
allow each of said ends of the jaw displacer to be detachably connected to the
20 mounting device of the first or second bone anchor, respectively.

 One of the possible treatments for sleep apnoea is to move a
patient's lower jaw slightly forward with respect to the upper jaw while sleeping.
According to the state of the art, this is done, for example, with the aid of
removable braces that rest on the teeth of the upper and lower jaw. Such systems
25 are described in documents US 2017/172785, WO 2010/087824, WO 2016/100577,
WO 2017/095971 or WO 2017/106896. However, these systems appear to be
disadvantageous in that they change the position of the teeth in the jaw after only a
short period of time due to the continuous pressure exerted on them while carrying
the braces.

30 Document WO 2010/037195 attempts to remedy this
disadvantage by providing an implant in the upper and lower jaw with a detachable
compression spring between these implants. However, this system does not appear
to provide satisfactory results. It is also difficult and inconvenient for a patient to

loosen and remove the compression spring from the mouth and replace it. In addition, the use of the system from WO 2010/037195 can result in a patient sleeping with open mouth, which increases the intensity of snoring.

Document US 2006/172251 describes a similar jaw displacement
5 system that is used in orthodontic applications, but contains a compression spring that is screwed to implants and therefore is not suitable for easy assembly or removal by a patient.

The invention aims to remedy these disadvantages by proposing a
10 jaw displacement system for the treatment of sleep apnoea and/or snoring with a jaw displacer that can be easily removed from or fitted back into his/her mouth by a patient. The use of the invention has virtually no effect on the position of the teeth and greatly reduces the incidence of sleep apnoea and/or snoring.

Thus, the invention concerns a sleep apnoea prevention system in
15 which a jaw displacer can be easily and quickly mounted in the mouth by the patient when going to sleep, while this jaw displacer can be easily removed from the mouth during the day. The system according to the invention hereby allows the mouth to be fully opened without any parts of the jaw displacer accidentally coming loose and possibly being swallowed, for example, during sleep.

To this aim, said connecting means include a hook and eye, with
20 the hook attached in a detachable manner to the eye.

Practically, said rod guide contains a spring element, so that the
rod guide can be deformed longitudinally between a compressed state and an extended state.

Said spring element is formed, for example, by a cylindrical coil
25 spring.

According to a preferred embodiment of the system according to
the invention, said rod guide contains a tube with a first tube end and a second tube
end, whereby said coupling means, preferably said eye, are provided at the first
tube end, while the spring element, when not compressed, extends along the tube to
30 at least the second tube end, the spring element being required to interact with said
rod, when the jaw displacement system is mounted in the oral cavity, in order to
exert a compressive force on said rod in the longitudinal direction of the rod guide.

According to an interesting embodiment of the jaw displacement system according to the invention, said tube is a telescopic tube with parts which can freely move in relation to one another, which parts can be moved between a retracted position and an extended position, in which said spring element exerts a compressive force on these parts according to said longitudinal direction in order to bring them into the extended position.

Advantageously, opposite ends of said spring element are connected to said first and second tube ends respectively.

According to a special embodiment, said spring element is, preferably, coaxial with said tube, while said tube extends at least partially into said spring element.

The invention also concerns a method of manufacturing a jaw displacement system for the treatment of sleep apnoea and/or snoring by moving the lower jaw forward, in a ventral direction, in relation to the upper jaw.

According to this method, a first and a second bone anchor are provided, with each bone anchor containing a fixation plate that allows the bone anchor to be attached to the bone of an upper or lower jaw. The fixation plate is connected to a connecting element that leads to a mounting device. The connecting element should stretch through gums when the bone anchor is attached to said bone so that the mounting device is in the oral cavity.

When manufacturing the jaw displacement system, a jaw displacer with a first and a second end is used as well, in which the jaw displacer contains a rod with said first end and a rod guide provided with said second end. The rod is mounted in a movable manner in the longitudinal direction of the rod guide and in a detachable manner in relation to the latter.

The rod guide is equipped with a spring element so that the rod guide can be deformed in its longitudinal direction between a compressed state and an extended state.

Further, coupling means are provided which allow to connect each of said ends of the jaw displacer in a detachable manner to the mounting device of the first or second bone anchor, respectively. The coupling means include, for example, a hook and eye, whereby the hook can be attached to the eye in a detachable manner.

This method is characterised in that the position of the mounting device of the first and second bone anchor respectively in relation to the associated fixation plate is selected such that, taking into account the dimensions and geometry of the lower and upper jaws, a connecting line is established between the coupling means of said ends of the jaw displacer, in particular a connecting line between the support points of the respective coupling means, extending on the side of the lower jaw below the rotation point of the lower jaw in relation to the upper jaw when both bone anchors are attached to the respective jaws, and the jaws are placed against each other in a closed position or, more generally, the mouth is closed. These support points are, for example, the support points between the hook and the eye of the respective coupling means when the jaw displacer is mounted on the bone anchors and the mouth is closed.

According to a particular embodiment of the method according to the invention, the length of the rod, increased by the length of the rod guide in said extended condition, is selected greater than the distance between said mounting elements of the first and second bone anchors if they were attached to the respective jaws and the jaws are in a wide open position, while the length of the rod, increased by the length of the rod guide when it is in a compressed condition, is smaller than that distance.

According to a preferred embodiment of the method according to the invention, a model of the upper and lower jaw is generated, whereby the first bone anchor is designed with a fixation plate that can be fitted to a selected part of the upper jaw, and said second bone anchor is designed with a fixation plate that can be fitted to a selected part of the lower jaw.

Other particularities and advantages of the invention will become clear from the following description of some specific embodiments of the jaw displacement system and its manufacturing method according to the invention. This description is given as an example only and does not limit the scope of the claimed protection; the reference figures used below refer to the accompanying drawings.

Figure 1 is a schematic side view of a skull equipped with a jaw displacement system according to the invention, when the jaws are in a closed position.

Figure 2 is a schematic side view of the skull with the jaw displacement system from figure 1 when the jaws are in an open position.

Figure 3 is a schematic representation of a bone anchor of the jaw displacement system according to the invention.

5 Figure 4 is a schematic longitudinal section of a jaw displacer according to an interesting embodiment of the invention, with a rod guide in an extended state.

Figure 5 is a schematic longitudinal section of the jaw displacer in figure 4, where the rod guide is in an intermediate position between a compressed
10 and an extended state.

Figure 6 is a schematic longitudinal section of the jaw displacer from figures 4 and 5, where the rod guide is in the compressed state.

Figure 7 is a schematic longitudinal section of the jaw displacer from figures 4 to 6, where the rod guide is in the compressed state and the rod is
15 removed from the rod guide.

Figure 8 is a schematic longitudinal section of a jaw displacer according to an alternative embodiment of the invention.

Figure 9 is a schematic longitudinal section of a jaw displacer according to a variant embodiment of the invention.

20 Figure 10 is a schematic representation of a bone anchor of the jaw displacement system according to another embodiment of the invention.

In the different figures, the same reference figures refer to the same or similar elements.

The invention in general concerns a jaw displacement system
25 which is particularly interesting for treating sleep apnoea. With the aid of this system, a patient's lower jaw is moved slightly forward in relation to the upper jaw while sleeping, in such a way that sleep apnoea is eliminated or at least the frequency of its occurrence is significantly reduced. In addition, this system also appears to ensure that snoring during sleep is at least reduced.

30 Existing systems for treating sleep apnoea are quite complex or cumbersome to apply. In addition, many systems that apply pressure to the teeth cause undesirable displacement of the teeth after a short period of time.

The system according to the invention not only allows an effective treatment of sleep apnoea without affecting the teeth, but is also very user-friendly in that it can be easily placed in the mouth by a patient before going to bed and can be easily removed after waking up. In addition, the risk that parts of the jaw displacement system unintentionally come off while sleeping is virtually non-existent. Indeed, if parts of the jaw displacement system were to accidentally come off, there is a risk that they would be swallowed or end up in the respiratory tract.

Figures 1 and 2 schematically show a jaw displacement system according to the invention when it is attached to a patient's jaws.

This jaw displacement system contains a first bone anchor 1 and a second bone anchor 2. Each bone anchor is equipped with a fixation plate 3 that allows the bone anchor 1 or 2 to be attached to the bone of an upper jaw 4 or of a lower jaw 5 with screws 11 that must extend through recesses 12 in the fixation plate 3. The fixation plate 3 connects to a connecting element 6 that leads to a mounting device 7. Figure 3 shows a schematic bone anchor 2.

The connecting element 6 must pass through gums when the bone anchor 1 or 2 is attached to said bone so that the mounting device 7 extends in the oral cavity. The connecting element 6 is preferably formed here by a curved, relatively stiff rod with a circular cross-section.

The mounting device 7 is formed by a cylindrical organ whose axis extends in line with the far end of the connection element 6 while a bore 8 is provided across this axis through the mounting device 7. Furthermore, according to the axial direction of the mounting device 7, a fixation screw 9 stretches out, which opens in the above-mentioned bore 8. Thus, this fixing screw 9 allows a hook 10, one end of which extends through the hole 8, to be attached to the mounting device 7.

Furthermore, the jaw displacement system includes a jaw displacer 13 with a first end 14 and a second end. This jaw displacer 13 contains a rod 16 with this first end 14 and a rod guide 17 provided with the second end 15. The rod 16 can be moved according to the longitudinal direction of the rod guide 17 and is mounted in a detachable manner in relation to the latter. Preferably, the rod 16 is formed by a straight rod with a circular cross-section.

In order to attach the jaw displacer 13 with its first and second ends 14 and 15 to the mounting devices 7 of the bone anchors 2 and 3, coupling means are provided. In particular, these coupling means allow each of said ends 14 and 15 of the jaw displacer 13 to be connected to the mounting device 7 of the first or second bone anchor 1 and 2 respectively in a detachable manner.

According to a preferred embodiment of the invention, each of these coupling means contains a hook 10 and an eye 18. The hook 10 can hereby hook in the eye 18 in a detachable manner in order to attach them to each other.

Figures 4 to 7 show the jaw displacer in more detail. In the proposed embodiment of the jaw displacer 13, each of the ends 14 and 15 is provided with an eye 18 of the coupling means. In addition, a hook 10 is attached to the mounting device 7 of each of the bone anchors 1 and 2, in the bore 8, to allow the jaw displacer 13 to be attached with the eyes 18 to the hooks 10 of the bone anchors in a detachable manner as will be described below.

Said rod guide 17 has a longitudinal axis 19 according to which it can be deformed between a compressed state and an extended state. For this purpose, the rod guide 17 contains a spring element 20 which is formed by a cylindrical coil spring.

Furthermore, the rod guide contains a tube 21 with a first tube end 22 and a second tube end 23. An eye 18 of said coupling means is fixed to this first tube end 22. This eye 18 is thus fixed to the rod guide 17 and has a central axis 24 that is almost parallel to the longitudinal direction of the rod guide 17. The central axis 24 of this eye 18 consequently extends, in this embodiment, parallel to the longitudinal axis 19.

The spring element 20, formed by the aforementioned cylindrical spring, extends along the tube 21 between its two ends 22 and 23. In the embodiment of the jaw displacer 13 shown in figures 4 to 7, said tube 21 is formed by a telescopic tube with parts 21a and 21b that can freely move in relation to each other. These parts 21a and 21b are movable between a retracted position, as shown in figures 6 and 7, and an extended position, as shown in figure 4.

The spring element 20 exerts a compressive force on these parts 21a and 21b according to the longitudinal direction mentioned above, so that they are moved to the extended position when no counter-pressure is exerted. In

particular, the spring element 20 exerts a compressive force between the ends 22 and 23 of the telescopic tube 21 and, preferably, it is firmly connected to these ends 22 and 23. The tube 21 extends into the spring element 20, and the tube 21 and the spring element 20 are coaxial.

5 In order to mount the jaw displacer 13 in the oral cavity on bone anchors 1 and 2 provided there, the eye 18, located at the end of rod 16, is attached to the hook 10 which is fixed to the first bone anchor 1. The rod guide 17 is attached with the corresponding eye 18 to the hook of the second bone anchor 2. The jaws 4 and 5 are then moved into an open position, as shown in figure 2, and
10 a compression force is manually applied to the free end 23 of the rod guide 17 in its longitudinal direction so that it deforms into the compressed state as shown in figure 7. In order to insert the rod 16 into the rod guide 17, its free end, opposite the eye 18, is placed opposite the end 23, as shown in figure 7. Preferably, care should be taken to ensure that the rod guide 17 and the rod 16 extend coaxially, at
15 least approximately. Next, the spring element 20 is relaxed so that the tube 21 slides over the rod 16.

In manufacturing the jaw displacement system, it has been ensured that the length of the rod 16, increased by the length of the rod guide 17 in said extended condition, is greater than the distance between the hooks 10 which
20 are fixed to the mounting elements 7 of the bone anchors 1 and 2 when they are attached to the respective jaws 4 and 5 and these jaws 4 and 5 are in a wide open position, while the length of the rod 16, increased by the length of the rod guide 17 when it is compressed, is smaller than said distance.

This ensures that, when the jaw displacer is mounted in the oral
25 cavity, the rod 16 can only be removed from the rod guide 17 if the rod guide is moved manually into the compressed state.

When the jaw displacer 13 is mounted in the oral cavity on the bone anchors 1 and 2, as shown in figures 1 and 2, as the jaws are moved into a closed position, the rod 16 will be gradually pushed further into the tube 21 of the
30 rod guide 17.

The rod 16 is equipped with a stop element 25 which is formed, for example, by a ring that is clamped around the rod 16 in a chosen position, as is shown in the figures. If necessary, this stop element can be formed by a stop tube

with a length chosen as a function of the geometry and the dimensions of the jaws 4 and 5. This stop tube is then pushed over the rod 16 until it rests against a thickening in the rod formed by, for example, said eye 18.

When the jaws 4 and 5 are closed, the rod 16 moves in the rod guide 17 until the stop element 25 comes into contact with the spring element 20 or the end 23 of said tube 21, as shown in figure 5. When the jaws 4 and 5 are closed further, a force of pressure is applied by the spring element 20, so that a force of pressure is applied in a ventral direction to the lower jaw 5 via the bone anchors 1 and 2. Depending on the compression force of the spring, the lower jaw 5 will thus be moved in the ventral direction with respect to the upper jaw 4.

When the jaws 4 and 5 are closed further, the spring element 20 is almost completely compressed as shown in figure 6, and the jaw displacer 13 thus forms an almost completely rigid element that ensures that the lower jaw 5 is moved in the ventral direction in relation to the upper jaw 4, which ensures that the sleep apnoea symptoms decrease or disappear when sleeping.

It should be noted that in certain cases, it is not required for the spring element 20 to be fully compressed when the jaws are in the closed position. For example, it may be sufficient to select the stiffness of the spring element 20 such that the lower jaw 5 will already be sufficiently displaced in relation to the upper jaw 4 in the event of a partial compression of the spring element 20.

Furthermore, the gradual compression of the spring element 20 ensures that the deformation of the jaw displacer 13 into the compressed state is slightly dampened so that no sudden loads affect the jaws 4 and 5 or components of the jaw displacement system.

When manufacturing the jaw displacement system, the position of the mounting device 7 of the first bone anchor 1 and of the second bone anchor 2 respectively in relation to the associated fixation plate 3 is selected such that, if both bone anchors 1 and 2 were attached to the respective jaws 4 and 5, a connecting line between the coupling means of the ends 14 and 15 of the jaw displacer 13 would extend to the side of the lower jaw 5 below the rotation point 27 of the lower jaw 5 in relation to the upper jaw 4.

The abovementioned connecting line 26 connects, in particular, the support points between the hook 10 and the eye 18 of each of the respective

coupling means when the jaws 4 and 5 are in the closed position or, i.e. when the mouth is closed. This prevents the spring element 20 applying a force that would move the jaws from the closed position into the open position.

5 This connecting line 26 can also be formed with sufficient accuracy, approximately, by the longitudinal axis 19 of the jaw displacer 13 when the jaws are in the closed position.

Preferably, the jaw displacement system is manufactured on the basis of a physical or digital model of the upper and lower jaw. Based on such a model thus generated, the first bone anchor 1 shall be designed with a fixation plate
10 3 that can be fitted to a selected portion of the upper jaw 4, and the second bone anchor 2 shall be designed such that its fixation plate 3 can be fitted to a selected portion of the lower jaw 5. On the basis of this model, also the length of the rod 16 or of the rod guide 17 can be selected as a function of the geometric shape and dimensions of the jaws 4 and 5.

15 On the mounting device 7 of the bone anchors 1 and 2, a U-shaped hook 10 of the coupling means is preferably provided such that, when the respective bone anchor 1 or 2 is attached to the jaw 4 or 5, this hook 10 will extend parallel to the dental arch of the jaw 4 or 5 or, in particular, it will extend in a plane which is tangential to this dental arch.

20 Such a choice for the orientation of the hooks 10 ensures that the jaw displacer can easily be mounted in and out of the oral cavity and that the coupling means do not unintentionally come loose.

Preferably, the hook 10 should be provided on the mounting device 7 in such a way that its open side extends to the side of the jaw 4 or 5
25 concerned, while the closed side of the hook extends to the occlusal plane.

In addition, figures 8 and 9 show alternative embodiments of the jaw displacer in a position similar to that of the jaw displacer in figure 5.

It is also possible for the hook 10 of the coupling means to be integrated with the mounting device 7, so that the hook 10 forms a whole with the
30 bone anchor 1 or 2.

Of course, the coupling means in the jaw displacement system or the method according to the invention are not limited to a hook 10 working together with an eye 18, but alternative means of coupling can be provided by the person

skilled in the art. For example, it is possible for these coupling means to contain two hooks which are connected in a detachable manner. For example, the coupling means may contain two corresponding parts which click together according to a male-female principle.

5 In certain cases, it may be interesting to give the jaw displacer a slightly curved shape in order to make it follow almost the same curve as the dental arch. In that case it is avoided, for example, that the jaw displacer makes disruptive contact with the teeth when opening or closing the mouth. In this way, the rod 16 and, if necessary, also the rod guide 17, are curved.

10 The invention is of course not limited to the embodiments of the jaw displacement system or of the method described above and shown in the accompanying figures. Within the scope of the invention, several alternatives can be considered.

15

CLAIMS

1. Method for manufacturing a jaw displacement system for the
5 treatment of sleep apnoea and/or snoring by moving the lower jaw (5) forward, in
the ventral direction, in relation to the upper jaw (4),

wherein a first and a second bone anchor (1,2) are provided, in
which each bone anchor (1,2) contains a fixation plate (3) that allows the bone
anchor (1,2) to be attached to the bone of an upper or lower jaw (4,5), wherein this
10 fixation plate (3) is connected to a connecting element (6) that leads to a mounting
device (7) and wherein the connecting element (6) must stretch through gums when
the bone anchor (1,2) is attached to said bone so that the mounting device (7) is
located in the oral cavity,

wherein a jaw displacer (13) with a first and a second far end
15 (14,15) is used, comprising a rod (16) with said first end (14) and a rod guide (17)
provided with said second end (15), wherein the rod (16) is movable in the
longitudinal direction of the rod guide (17) and is detachable in relation to the
latter,

wherein said rod guide (17) is further equipped with a spring
20 element (20) so that the rod guide (17) can be deformed in its longitudinal direction
between a compressed state and an extended state,

wherein coupling means are provided which allow each of said
ends (14,15) of the jaw displacer (13) to be connected in a detachable manner to the
mounting device (7) of the first bone anchor (1) or the second bone anchor (2)
25 respectively, **characterised in that**

the position of the mounting device (7) of the first bone anchor
(1) and of the second bone anchor (2) respectively in relation to the corresponding
fixation plate (3) is selected such that, if both bone anchors (1,2) were attached to
the respective jaws (4,5), a connecting line (26) would be established between the
30 coupling means of said ends (14,15) of the jaw displacer (13), in particular a
connecting line between support points between the hook (10) and the eye (18) of
the respective coupling means, extending on the side of the lower jaw (5) below the

rotation point (27) of the lower jaw (5) in relation to the upper jaw (4) when the jaws (4,5) are in a closed position.

2. Method according to claim 1, in which said rod guide (17) is made hollow with an open end opposite the second end (15), in order to allow the
5 rod (16) to be moved and guided in the rod guide (17) according to its longitudinal direction.

3. Method according to claim 1 or 2, where the length of the rod (16) plus the length of the rod guide (17) in said extended condition is selected greater than the distance between the aforementioned mounting elements (7) of the
10 first and second bone anchors (1,2) when attached to the respective jaw (4,5) and the jaws (4,5) are in a wide open position, whereas the length of the rod (16) increased by the length of the rod guide (17) when it is compressed, is smaller than this distance.

4. Method according to any one of claims 1 to 13, where a U-shaped hook (10) of said coupling means is provided on the mounting device (7) of
15 said bone anchors (1,2) in such a way that, when the respective bone anchor (1,2) is attached to the relevant jaw (4,5), this hook (10) will extend parallel to the dental arch of this jaw (4,5) or, in particular, in a plane which is tangential to this dental arch.

5. Method according to claim 4, where said hook (10) is provided on the mounting device (7) in such a way that its open side extends to the
20 side of the jaw concerned (4,5), while the closed side of the hook (10) extends to the occlusal plane.

6. Method according to any one of claims 1 to 5, where a stop element (25) is fitted to said rod (16), where this stop element (25) works together
25 with the rod guide (17) in order to exert a compressive force between said mounting elements (7) when said bone anchors (1,2) are attached to the respective jaws (4,5).

7. Method according to any one of claims 1 to 6, where said coupling means include a hook (10) and eye (18), the hook of which can be fixed to
30 the eye in a detachable manner.

8. Method according to claim 7, where said connecting line (26) between the coupling means of said ends (14,15) of the jaw displacer (13) connects support points between the hook (10) and the eye (18) of the respective coupling

means and extends on the side of the lower jaw (5) below the rotation point (27) of the lower jaw (5) in relation to the upper jaw (4) when the jaws (4,5) are in a closed position.

5 9. Method according to claim 7 or 8, where an eye (18) of said coupling means is attached to one end (14,15) of the jaw displacer (13) in such a way that the eye (18) has a central axis (24) which is almost parallel to the longitudinal axis of the jaw displacer device (13).

10 10. Method according to claim 9, where said eye (18) is provided at said second end (15) of the jaw displacer in such a way that its central axis (24) is substantially parallel to the longitudinal axis of the rod guide (17).

11. Method according to any one of claims 7 to 10, where an eye (18) of said coupling means is provided at one end (14,15) of the jaw displacer (13) in such a way that this eye (18) has a central axis substantially transverse to the longitudinal axis of the jaw displacer (13).

15 12. Method according to claim 11, where said eye (18) is provided at said first end (14) of the jaw displacer (13) in such a way that its central axis is substantially transverse to the longitudinal direction of the rod (16), this central axis intersecting, preferably, the longitudinal axis (19) of the jaw displacer (13).

20 13. Method according to any one of claims 1 to 12, in which a model of the upper jaw (4) and of the lower jaw (5) is generated, in which said first bone anchor (1) is designed with a fixation plate (3) that can be fitted to a selected part of the upper jaw (4) and said second bone anchor (2) is designed with a fixation plate (3) that can be fitted to a selected part of the lower jaw (5).

25 14. A jaw displacement system for the treatment of sleep apnoea and/or snoring, with:

30 - a first and a second bone anchor (1,2), wherein each bone anchor (1,2) contains a fixation plate (3) which is provided to attach the bone anchor (1,2) to the bone of an upper or lower jaw (4,5), wherein this fixation plate (3) is connected to a connecting element (6) that leads to a mounting device (7) and wherein the connecting element (6) must pass through gums when the bone anchor (1,2) is attached to said bone, such that the mounting device (7) is located in the oral cavity,

- a jaw displacer (13) with a first and a second far end (14,15), having a rod (16) with the first end (14) and a rod guide (17) provided with the second end (15), the rod (16) being movable in the longitudinal direction of the rod guide (17) and detachable in relation to the latter,

5 - coupling means allowing each of said ends (14,15) of the jaw-displacer (13) to be detachably connected to the mounting device (7) of the first or second bone anchor (1,2) respectively,

characterised in that

10 said rod guide (17) contains a spring element (20) so that the rod guide (17) can be deformed in its longitudinal direction between a compressed state and an extended state.

15 15. Jaw displacement system according to claim 14, where the rod guide (17) contains a tube (21) with a first tube end (22) and a second tube end (22), where said coupling means are provided at the first tube end (22), while the spring element (20) extends along the tube (21) in an uncompressed state up to at least the second tube end (23), where the spring element (20) has to work together with said rod (16), when the jaw displacement system is mounted in the oral cavity, in order to exert on this rod (16) a compressive force in the longitudinal direction of the rod guide (17).

20 16. Jaw displacement system according to claim 15, where the spring element (20) is coaxial to said tube (21).

17. Jaw displacement system according to claim 15 or 16, where the tube (21) extends at least partially in the spring element (20).

25 18. Jaw displacement system according to any one of claims 18 to 17, in which said tube (21) is a telescopic tube with parts which can freely move in relation to each other (21a,21b), which parts can be moved between a retracted position and an extended position, in which said spring element (20) exerts a compressive force on these parts (21a,21b) according to said longitudinal direction in order to bring them in said extended position.

30 19. Jaw displacement system according to any one of claims 15 to 18, where opposite ends of said spring element (20) are connected with respectively said first and said second tube ends (22,23).

20. Jaw displacement system according to claim 14, in which said rod guide (17) contains a tube (21) with a first tube end (22) and a second tube end (22), in which said coupling means, preferably said eye (18), are provided at the first tube end (22), while the spring element (20) connects to the second tube end (23) and extends in the extension of the tube (21), whereby the spring element (20) must work together with said rod (16), when the jaw displacement system is mounted in the oral cavity, in order to exert on this rod (16) a compressive force according to the longitudinal direction of the rod guide (17).

21. Jaw displacement system according to any one of claims 15 to 20, in which said rod (16) is provided with a stop element (25) for said spring element (20) and/or said tube (21).

22. Jaw displacement system according to any one of claims 14 to 21, where the spring element (20) includes a cylindrical coil spring.

23. Jaw displacement system according to any one of claims 14 to 12, in which said coupling means contain a hook (10) and eye (18), in which the hook (10) can be attached in a detachable manner in the eye (18).

24. Jaw displacement system according to claim 23, in which the aforementioned eye (18) is fixed with the aforementioned rod guide (17) and has a central axis (24) that is substantially parallel to the longitudinal direction of the rod guide (17), while the aforementioned hook (10) is provided on the mounting device (7) of the respective bone anchor (1,2).

25. Jaw displacement system according to claim 23 or 24, where said eye (18) is fixed to said second end (14).

26. A jaw displacement system for the treatment of sleep apnoea and/or snoring, with:

- a first and a second bone anchor (1,2), where each bone anchor (1,2) contains a fixation plate (3) provided to attach the bone anchor (1,2) to the bone of an upper or lower jaw (4,5), where this fixation plate (3) is connected to a connecting element (6) that leads to a mounting device (7) and where the connecting element (6) must pass through gums when the bone anchor (1,2) is attached to said bone, such that the mounting device (7) is located in the oral cavity,

- a jaw displacer (13) with a first and second end (14,15), having a rod (16) with said first end (14) and a rod guide (17) provided with said second end

(15), the rod (16) being movable in the longitudinal direction of the rod guide (17) and detachable in relation to the latter,

- coupling means allowing each of said ends (14,15) of the jaw-displacer (13) to be connected in a detachable manner to the mounting device (7) of the first or second bone anchor (1,2), respectively,

characterised in that

said coupling means comprise a hook (10) and eye (18), where the hook (10) can be attached to the eye (18) in a detachable manner.

27. Jaw displacement system according to claim 26, in which the aforementioned eye (18) is fixed with the aforementioned rod guide (17) and has a central axis (24) that is almost parallel to the longitudinal direction of the rod guide (17), while the aforementioned hook (10) is provided on the mounting device (7) of the respective bone anchor (1.2).

28. Jaw displacement system according to claim 26 or 27, where said eye (18) is fixed to said second end (14).

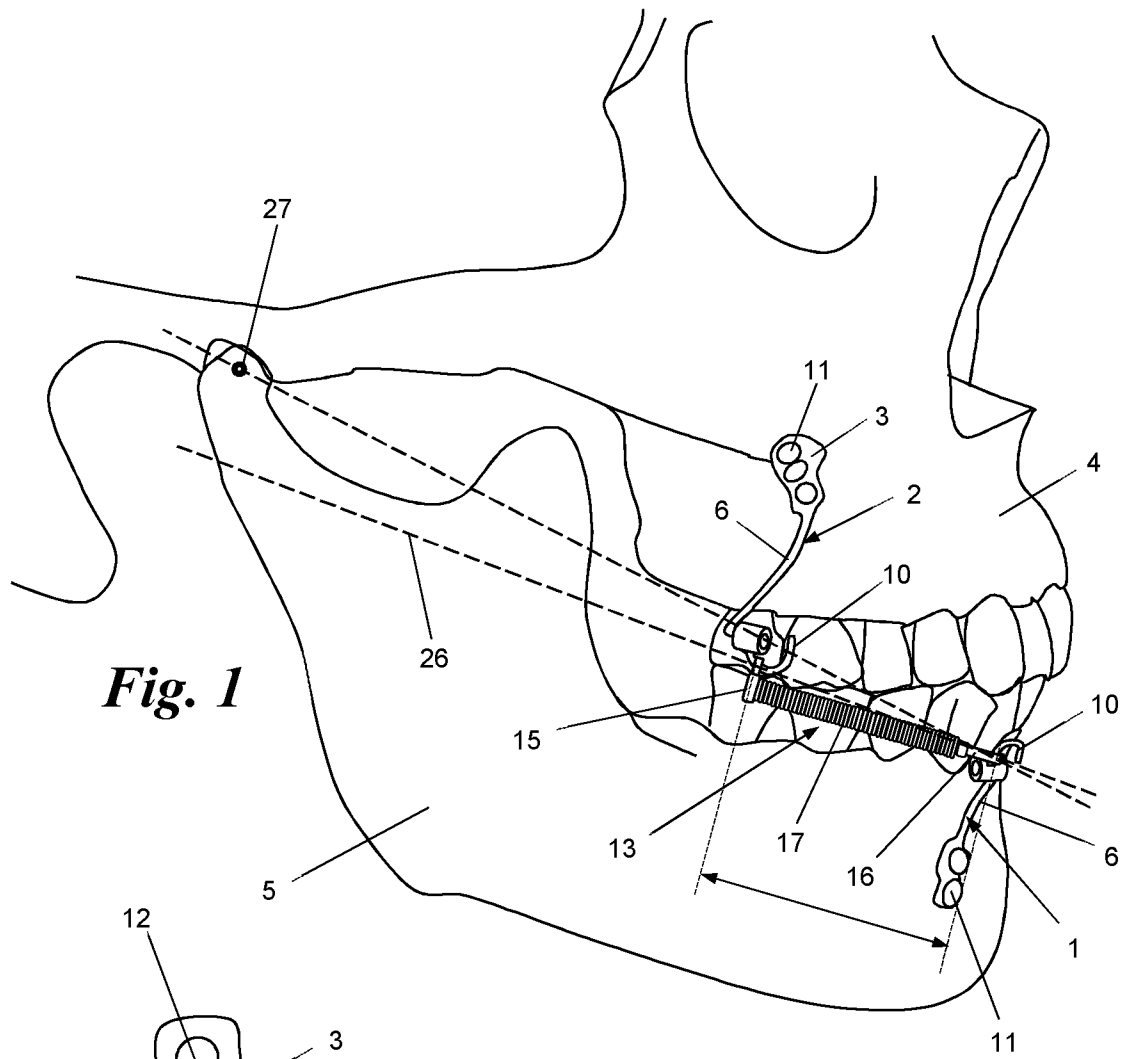

Fig. 1

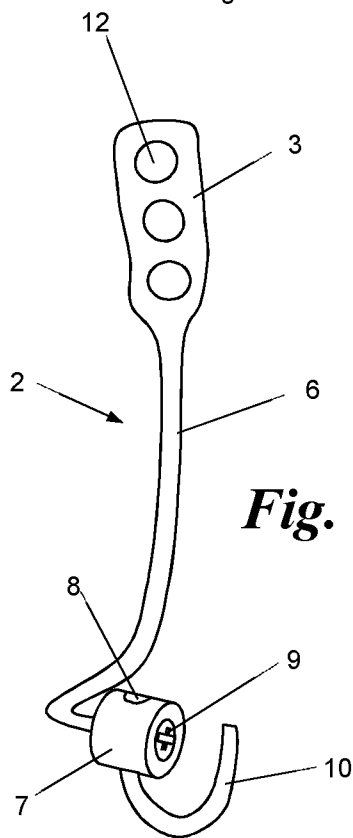

Fig. 3

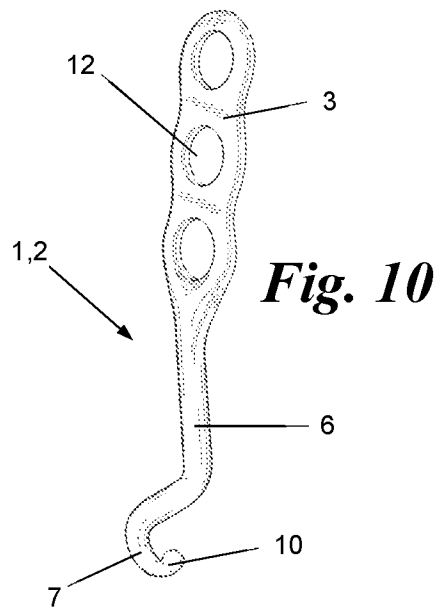

Fig. 10

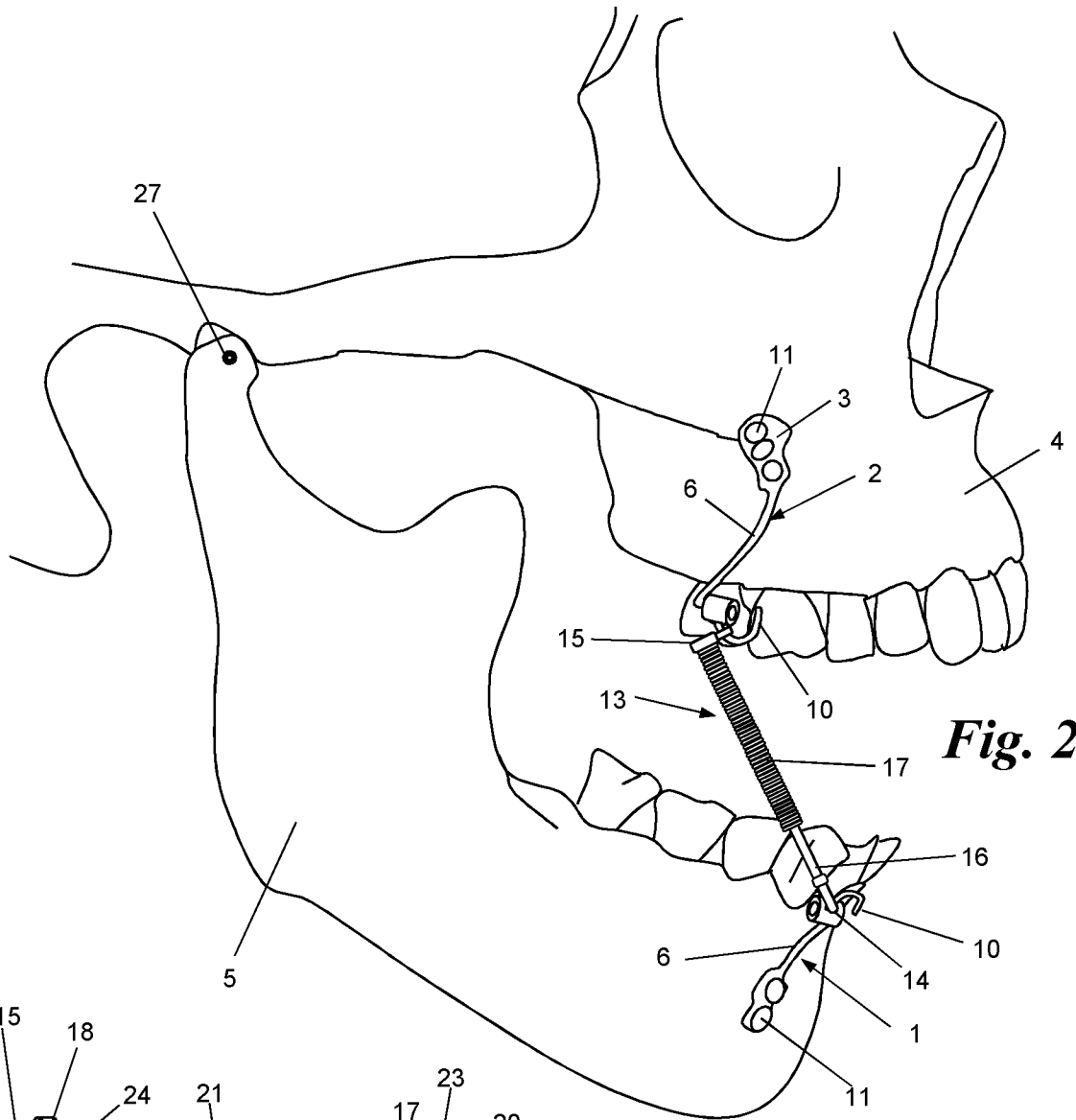

Fig. 2

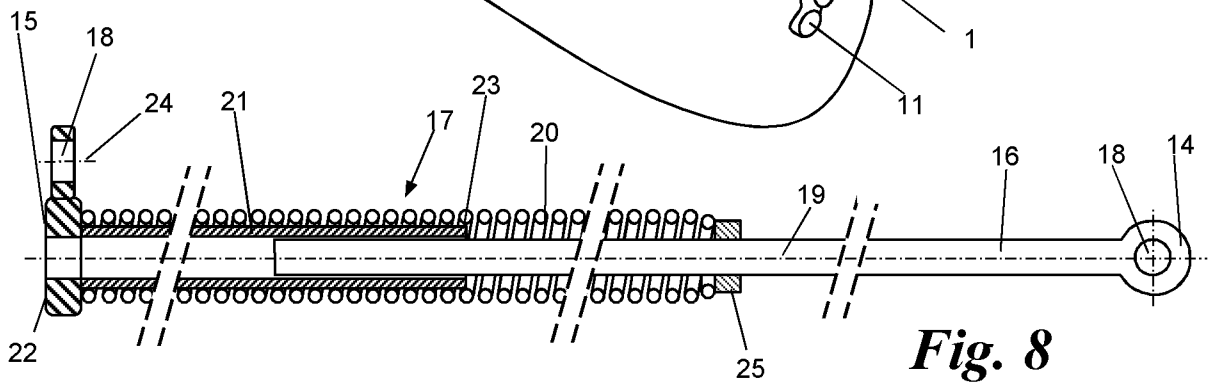

Fig. 8

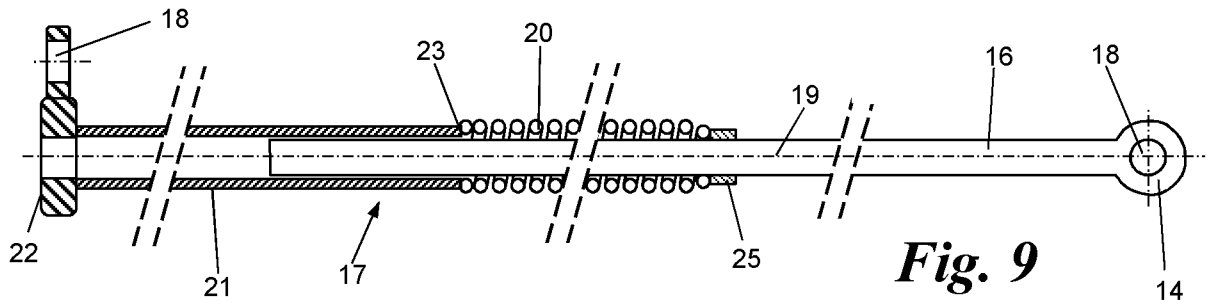

Fig. 9

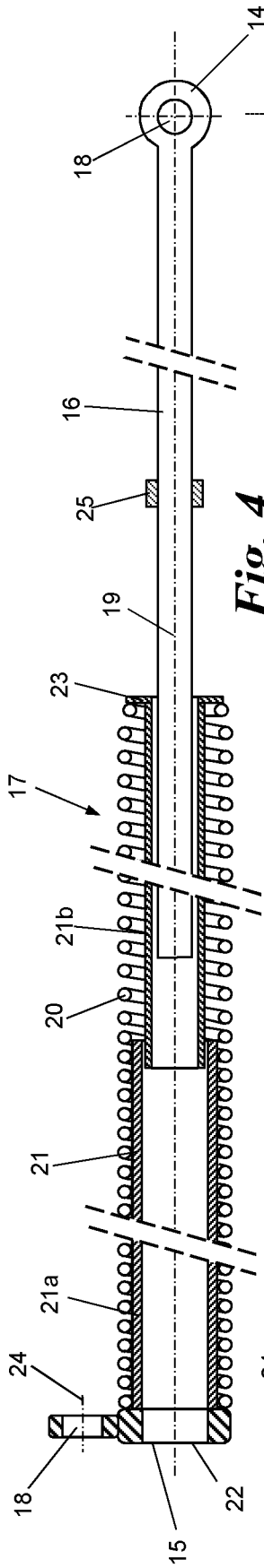

Fig. 4

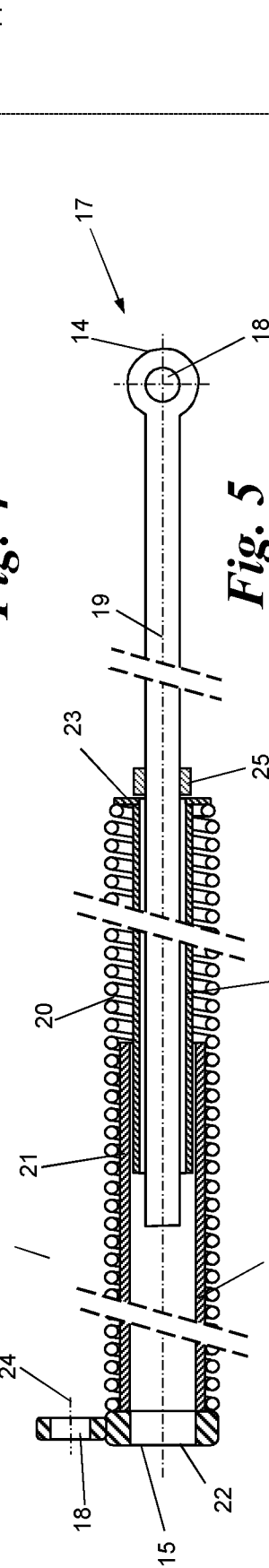

Fig. 5

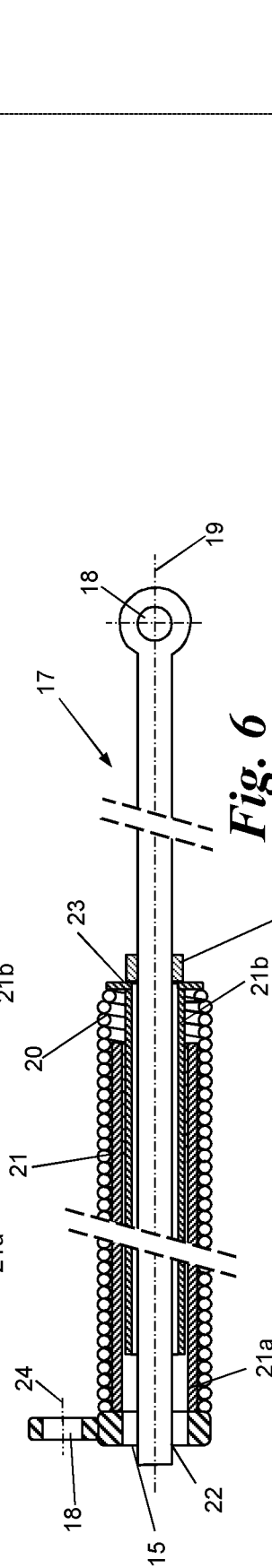

Fig. 6

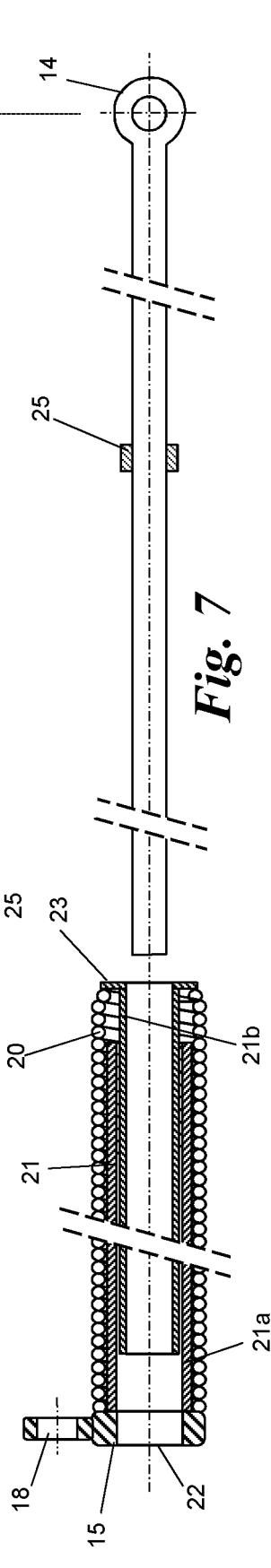

Fig. 7

INTERNATIONAL SEARCH REPORT

International application No

PCT/IB2019/054558

A. CLASSIFICATION OF SUBJECT MATTER

INV. A61F5/56
ADD.

According to International Patent Classification (IPC) or to both national classification and IPC

B. FIELDS SEARCHED

Minimum documentation searched (classification system followed by classification symbols)

A61F

Documentation searched other than minimum documentation to the extent that such documents are included in the fields searched

Electronic data base consulted during the international search (name of data base and, where practicable, search terms used)

EPO-Internal, WPI Data

C. DOCUMENTS CONSIDERED TO BE RELEVANT

Category*	Citation of document, with indication, where appropriate, of the relevant passages	Relevant to claim No.
Y	US 2010/139666 A1 (BONNAURE PIERRE [FR]) 10 June 2010 (2010-06-10)	14-25
A	paragraph [0057] - paragraph [0059] paragraph [0062] paragraph [0063] - paragraph [0070]; figure 2 paragraph [0075]	1-13
Y	EP 1 073 379 A1 (MINNESOTA MINING & MFG [US]) 7 February 2001 (2001-02-07)	14-25
A	paragraph [0020] - paragraph [0029] paragraph [0035] - paragraph [0055]; figures 1-8	1-13
Y	WO 2010/037195 A1 (BLANC KATYA GUERRA NASSIF FARAH [BR]; TESCH RICARDO DE SOUZA [BR]) 8 April 2010 (2010-04-08)	14-25
A	the whole document	1-13
	----- -/--	

Further documents are listed in the continuation of Box C.

See patent family annex.

* Special categories of cited documents :

"A" document defining the general state of the art which is not considered to be of particular relevance

"E" earlier application or patent but published on or after the international filing date

"L" document which may throw doubts on priority claim(s) or which is cited to establish the publication date of another citation or other special reason (as specified)

"O" document referring to an oral disclosure, use, exhibition or other means

"P" document published prior to the international filing date but later than the priority date claimed

"T" later document published after the international filing date or priority date and not in conflict with the application but cited to understand the principle or theory underlying the invention

"X" document of particular relevance; the claimed invention cannot be considered novel or cannot be considered to involve an inventive step when the document is taken alone

"Y" document of particular relevance; the claimed invention cannot be considered to involve an inventive step when the document is combined with one or more other such documents, such combination being obvious to a person skilled in the art

"&" document member of the same patent family

Date of the actual completion of the international search

23 July 2019

Date of mailing of the international search report

01/10/2019

Name and mailing address of the ISA/

European Patent Office, P.B. 5818 Patentlaan 2
NL - 2280 HV Rijswijk
Tel. (+31-70) 340-2040,
Fax: (+31-70) 340-3016

Authorized officer

Jansson Godoy, Nina

INTERNATIONAL SEARCH REPORT

International application No.
PCT/IB2019/054558

Box No. II Observations where certain claims were found unsearchable (Continuation of item 2 of first sheet)

This international search report has not been established in respect of certain claims under Article 17(2)(a) for the following reasons:

1. Claims Nos.:
because they relate to subject matter not required to be searched by this Authority, namely:

2. Claims Nos.:
because they relate to parts of the international application that do not comply with the prescribed requirements to such an extent that no meaningful international search can be carried out, specifically:

3. Claims Nos.:
because they are dependent claims and are not drafted in accordance with the second and third sentences of Rule 6.4(a).

Box No. III Observations where unity of invention is lacking (Continuation of item 3 of first sheet)

This International Searching Authority found multiple inventions in this international application, as follows:

see additional sheet

1. As all required additional search fees were timely paid by the applicant, this international search report covers all searchable claims.
2. As all searchable claims could be searched without effort justifying an additional fees, this Authority did not invite payment of additional fees.
3. As only some of the required additional search fees were timely paid by the applicant, this international search report covers only those claims for which fees were paid, specifically claims Nos.:
4. No required additional search fees were timely paid by the applicant. Consequently, this international search report is restricted to the invention first mentioned in the claims; it is covered by claims Nos.:

1-25

Remark on Protest

- The additional search fees were accompanied by the applicant's protest and, where applicable, the payment of a protest fee.
- The additional search fees were accompanied by the applicant's protest but the applicable protest fee was not paid within the time limit specified in the invitation.
- No protest accompanied the payment of additional search fees.

INTERNATIONAL SEARCH REPORT

International application No

PCT/IB2019/054558

C(Continuation). DOCUMENTS CONSIDERED TO BE RELEVANT

Category*	Citation of document, with indication, where appropriate, of the relevant passages	Relevant to claim No.
A	FR 3 011 460 A1 (D INTRONO CHRISTOPHE [FR]) 10 April 2015 (2015-04-10) the whole document -----	1-25

INTERNATIONAL SEARCH REPORT

Information on patent family members

International application No PCT/IB2019/054558

Patent document cited in search report	Publication date	Patent family member(s)	Publication date
US 2010139666	A1	10-06-2010	AT 471133 T 15-07-2010
			BR PI0719099 A2 03-12-2013
			CA 2668206 A1 29-05-2008
			EP 2081525 A1 29-07-2009
			ES 2347720 T3 03-11-2010
			FR 2908980 A1 30-05-2008
			MA 31222 B1 01-03-2010
			PT 2081525 E 23-09-2010
			US 2010139666 A1 10-06-2010
			WO 2008061725 A1 29-05-2008

EP 1073379	A1	07-02-2001	AU 9032498 A 08-11-1999
			DE 1073379 T1 23-08-2001
			DE 69827672 T2 24-11-2005
			EP 1073379 A1 07-02-2001
			JP 4309054 B2 05-08-2009
			JP 2002512074 A 23-04-2002
			US 5964588 A 12-10-1999
			WO 9953858 A1 28-10-1999

WO 2010037195	A1	08-04-2010	BR MU8803125 U2 06-07-2010
			WO 2010037195 A1 08-04-2010

FR 3011460	A1	10-04-2015	NONE

FURTHER INFORMATION CONTINUED FROM PCT/ISA/ 210

This International Searching Authority found multiple (groups of) inventions in this international application, as follows:

1. claims: 1-25

A manufacturing method/jaw displacement system wherein said rod guide contains a spring element so that the rod guide can be deformed in its longitudinal direction between a compressed state and an extended state.

2. claims: 26-28

A jaw displacement system wherein the coupling means comprise a hook and eye, where the hook can be attached to the eye in a detachable manner.
