

Nov. 30, 1965

P. F. JETTINGHOFF

3,220,507

THREE-PIECE TRI-FLOW MUFFLER

Filed Jan. 13, 1964

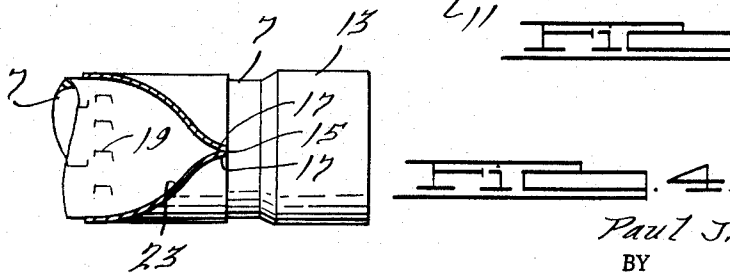
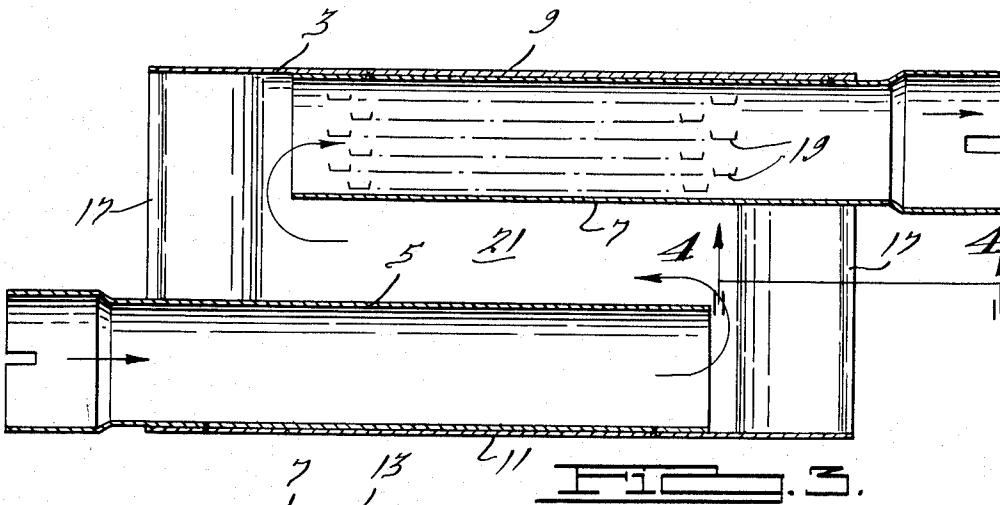
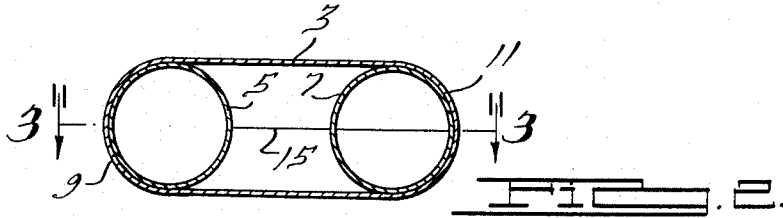
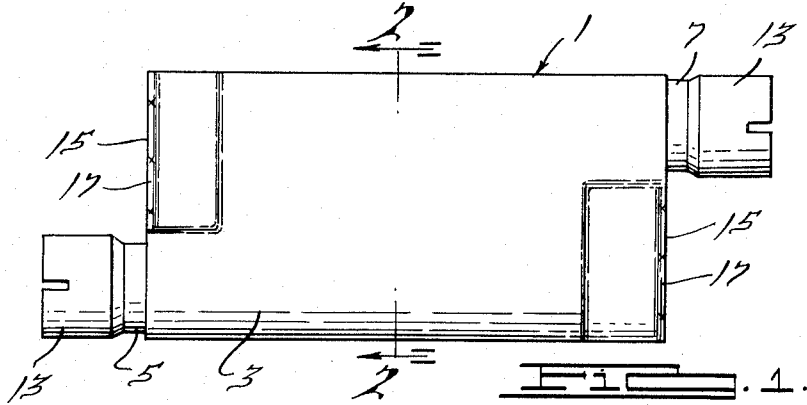

INVENTOR.

Paul J. Jettinghoff.

BY

Harness Dickey & Piree.  
ATTORNEYS.

1

3,220,507

**THREE-PIECE TRI-FLOW MUFFLER**

Paul F. Jettinghoff, Jackson, Mich., assignor to Walker Manufacturing Company, a corporation of Delaware

Filed Jan. 13, 1964, Ser. No. 337,349

3 Claims. (Cl. 181-53)

My invention relates to devices for attenuating sound in gases and, in particular, concerns a muffler useful in the exhaust systems of internal combustion engines.

It is an object of my invention to provide a small tri-flow silencing component useful in distributed silencer exhaust systems.

It is another object of the invention to provide a muffler construction that is simple and readily produced.

It is another object of the invention to provide a small, efficient gas silencing device.

The invention accomplishes the foregoing and other objects by means of a three-piece muffler construction in which the end headers and internal partitions have been eliminated. The muffler comprises overlapping inlet and outlet tubes and a shell. The tubes are secured to the shell for mutual reinforcement and the ends of the shell are closed by pinching down opposite sides of the shell ends.

The invention is illustrated in the accompanying drawings in which:

FIGURE 1 is a plan view of a muffler embodying the invention;

FIG. 2 is a cross section along line 2-2 of FIG. 1;

FIG. 3 is an enlarged cross section along the line 3-3 of FIG. 2; and

FIG. 4 is a cross section along the line 4-4 of FIG. 3.

The muffler 1 has a shell 3 which is initially an open-ended tube having the oval cross section shown in FIG. 2. There is an inlet tube 5 and an outlet tube 7 and these preferably fit snugly against opposite sides 9 and 11 of the shell, as seen in FIG. 2, and are spotwelded to it at a plurality of points, as indicated by the designations *x* in the drawings.

The tubes 5 and 7 overlap inside the shell 3 and each extends out of an end of the shell and is expanded and slotted at 13 so that it may receive and be clamped to a gas conduit (not shown). The ends of the shell 3 are closed in joints 15 by pinching down and spotwelding together lips 17 on the top and bottom sides of the shell. The tubes 5 and 7 provide reinforcement for the shell against undue shell wall collapse during the end pinch down operation.

Preferably, the wall of at least one of the tubes is louvered and such louvers are shown at 19 in tube 7.

2

Various other louver arrangements may be used as desired.

In use, gas enters inlet tube 5 and, as it is imperforate, flows down to the end where it enters chamber 21 defined by the shell 3. It then reverses its direction to flow back in chamber 21 until it reaches the inlet end of tube 7 where it reverses direction to flow out of the muffler 1. Cross bleeding and high frequency sound attenuation are provided by louvers 19. The tapered shape of the ends of the shell as seen at 23 extract sound energy from the gas upon impingement, particularly at the end of the imperforate inlet tube 5.

In one preferred embodiment of the invention the shell 3 is 10" long, 5¼" wide, and 1¾" deep. Thus, the unit occupies very little space but still gives the benefits of a tri-flow gas pattern.

Modifications in the structure shown may be made without departing from the spirit and scope of the invention.

I claim:

1. A muffler consisting of only three parts, said three parts comprising an inlet tube, an outlet tube, and a shell, said tubes and shell being parallel, said shell being oval in cross section and said tubes being fitted against and secured to opposite sides of the shell for mutual reinforcement, opposite ends of the shell having opposite sides extending inwardly to meet together to close the ends of the shell, said tubes being longitudinally overlapping in said shell.

2. The invention set forth in claim 1 wherein the ends of said tubes inside said shell are open and are spaced inwardly from the ends of the shell.

3. The invention set forth in claim 1 wherein at least one of said tubes is perforate.

**References Cited by the Examiner**

**UNITED STATES PATENTS**

1,619,115	3/1927	Gray	-----	181-61	X
2,115,128	4/1938	Starkweather et al.	----	181-57	
2,166,408	7/1939	Hoyle	-----	181-54	
2,251,880	8/1941	Cary et al.	-----	181-48	
3,003,578	10/1961	Ewashuk	-----	181-61	X
3,158,222	11/1964	Richmond	-----	181-61	X

**FOREIGN PATENTS**

892,780	3/1962	Great Britain.
355,107	12/1937	Italy.

LEO SMILOW, Primary Examiner.