



INTERNATIONAL APPLICATION PUBLISHED UNDER THE PATENT COOPERATION TREATY (PCT)

<p>(51) International Patent Classification ⁶ : G06K 7/10</p>	<p>A1</p>	<p>(11) International Publication Number: WO 00/39742</p> <p>(43) International Publication Date: 6 July 2000 (06.07.00)</p>
<p>(21) International Application Number: PCT/US99/31043</p> <p>(22) International Filing Date: 29 December 1999 (29.12.99)</p> <p>(30) Priority Data: 60/114,028 29 December 1998 (29.12.98) US</p> <p>(71) Applicant: SYMBOL TECHNOLOGIES, INC. [US/US]; One Symbol Plaza, Holtsville, NY 11742-1300 (US).</p> <p>(72) Inventors: MULLA, Altaf; 2073 Washington Street, Merrick, NY 11566 (US). BARKAN, Edward; 3 Enchanted Woods Court, Miller Place, NY 11764 (US). FAN, Lisa; 23 Tyram Street, Commack, NY 11725 (US). JONES, Gregory; 7038 20th Place NE, Seattle, WA 98115 (US). HETFIELD, Margaret; 269 Laurel Road, East Northport, NY 11731 (US). GIORDANO, Joseph; 231 Bayville Avenue, Bayville, NY 11709 (US). GOFMAN, Yuri; P.O. Box 184, Bohemia, NY 11716 (US). SANDERS, Robert; 4 Equine Avenue, St. James, NY 11780 (US). STRATIENCO, Daniella; 12 Hillside Road, Sound Beach, NY 11789 (US).</p> <p>(74) Agent: MILLER, Samuel, C., III; Burns, Doane, Swecker & Mathis L.L.P., P.O. Box 1404, Alexandria, VA 22313-1404 (US).</p>		<p>(81) Designated States: AU, BR, CA, CN, JP, European patent (AT, BE, CH, CY, DE, DK, ES, FI, FR, GB, GR, IE, IT, LU, MC, NL, PT, SE).</p> <p>Published <i>With international search report.</i></p>

(54) Title: COMPACT BAR CODE SCANNER

(57) Abstract

A compact optical code reader (30) is disclosed having multiple functions and a unique shape and configuration of actuators (36, 38) and indicators (162). A system including a cradle (32), interface and host computer, capable of performing various data processing functions involving scanned data.

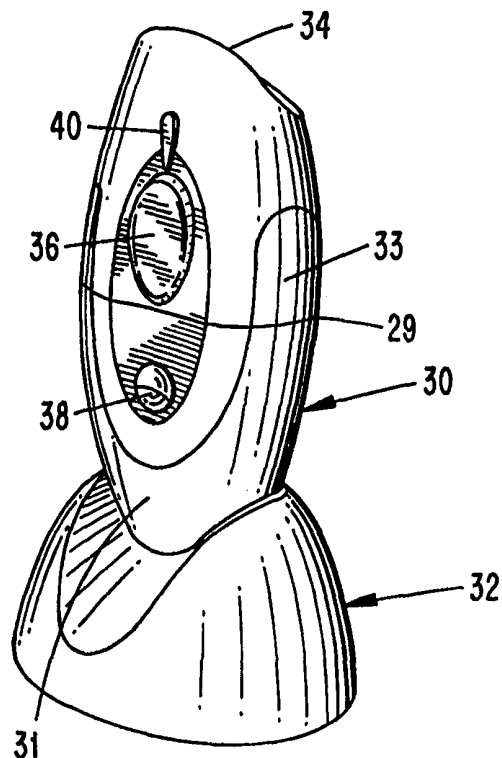

FOR THE PURPOSES OF INFORMATION ONLY

Codes used to identify States party to the PCT on the front pages of pamphlets publishing international applications under the PCT.

AL	Albania	ES	Spain	LS	Lesotho	SI	Slovenia
AM	Armenia	FI	Finland	LT	Lithuania	SK	Slovakia
AT	Austria	FR	France	LU	Luxembourg	SN	Senegal
AU	Australia	GA	Gabon	LV	Latvia	SZ	Swaziland
AZ	Azerbaijan	GB	United Kingdom	MC	Monaco	TD	Chad
BA	Bosnia and Herzegovina	GE	Georgia	MD	Republic of Moldova	TG	Togo
BB	Barbados	GH	Ghana	MG	Madagascar	TJ	Tajikistan
BE	Belgium	GN	Guinea	MK	The former Yugoslav Republic of Macedonia	TM	Turkmenistan
BF	Burkina Faso	GR	Greece	ML	Mali	TR	Turkey
BG	Bulgaria	HU	Hungary	MN	Mongolia	TT	Trinidad and Tobago
BJ	Benin	IE	Ireland	MR	Mauritania	UA	Ukraine
BR	Brazil	IL	Israel	MW	Malawi	UG	Uganda
BY	Belarus	IS	Iceland	MX	Mexico	US	United States of America
CA	Canada	IT	Italy	NE	Niger	UZ	Uzbekistan
CF	Central African Republic	JP	Japan	NL	Netherlands	VN	Viet Nam
CG	Congo	KE	Kenya	NO	Norway	YU	Yugoslavia
CH	Switzerland	KG	Kyrgyzstan	NZ	New Zealand	ZW	Zimbabwe
CI	Côte d'Ivoire	KP	Democratic People's Republic of Korea	PL	Poland		
CM	Cameroon	KR	Republic of Korea	PT	Portugal		
CN	China	KZ	Kazakstan	RO	Romania		
CU	Cuba	LC	Saint Lucia	RU	Russian Federation		
CZ	Czech Republic	LI	Liechtenstein	SD	Sudan		
DE	Germany	LK	Sri Lanka	SE	Sweden		
DK	Denmark	LR	Liberia	SG	Singapore		
EE	Estonia						

-1-

COMPACT BAR CODE SCANNER**BACKGROUND**

5 This application claims priority to U.S. provisional Application Serial
No. 60/114,028 filed December 29, 1998 which is hereby incorporated by
reference. This application is also a Continuation-in-Part of Application Serial
No. 09/067,124 filed April 27, 1998, (which is hereby incorporated by
reference) which is a Continuation-in-Part of Serial No. 08/820,048 filed March
10 18, 1997, now U.S. Patent No. 5,744,791, which is a Division of Application
Serial No. 08/686,157 filed July 24, 1996, now U.S. Patent No. 5,801,371,
which is a Division of Application Serial No. 08/407,577 filed March 30, 1995,
now U.S. Patent No. 5,600,121.

15

FIELD OF THE INVENTION

The present invention relates to methods and apparatus for electro-
optically reading symbols, for example, bar code or matrix array symbols and,
in preferred embodiments, to a compact, hand held optical code reading system
20 with multiple user actuatable functions and feedback signals.

BACKGROUND AND OBJECTS

25 Code readers are known in the prior art for reading various symbols such
as bar code symbols appearing on a label or on the surfaces of an article. The
bar code symbol itself is a coded pattern of indicia comprised of a series of bars
of various widths spaced apart from one another to bound spaces of various
widths, the bars and spaces having different light reflecting characteristics. The
readers in scanning or imaging systems electro-optically transform the graphic

-2-

indicia into electrical signals, which are decoded into information, typically descriptive of the article or some characteristic thereof. Such characteristics are conventionally represented in digital form and used as an input to a data processing system for applications in point-of-sale processing, inventory control and the like. Scanning systems of this general type have been disclosed, for example, in U.S. Patent Nos. 4,251,798; 4,369,361; 4,387,297; 4,409,470; 4,760,248; 4,896,026 and 5,600,121, all of which have been assigned to the same assignee as the instant application. As disclosed in some of the above patents, such systems may employ a hand held, portable laser scanning device held by a user, which is configured to allow the user to aim the device, and more particularly, a light beam, at a targeted symbol to be read.

The light source in a laser scanner bar code reader is typically a semiconductor laser. The use of semiconductor devices as the light source is especially desirable because of their small size, low cost and low voltage requirements. The laser beam is optically modified, typically by an optical assembly, to form a beam spot of a certain size at the target distance. It is preferred that the cross section of the beam spot at the target distance be approximately the same as the minimum width between regions of different light reflectivity, *i.e.*, the bars and spaces of the symbol.

In the laser beam scanning systems known in the art, the laser light beam is directed by a lens or other optical components along the light path toward a target that includes a bar code symbol on the surface. The moving-beam scanner operates by repetitively scanning the light beam in a line, pattern or series of lines across the symbol by means of motion of a scanning component, such as the light source itself or a mirror disposed in the path of the light beam. The scanning component may either sweep the beam spot across the symbol and trace a scan line across the pattern of the symbol, or scan the field of view of the scanner, or both.

-3-

Bar code reading systems also include a sensor or photo detector which detects light reflected or scattered from the symbol. The photo detector or sensor is positioned in the scanner in an optical path so that it has a field of view which ensures the capture of a portion of the light which is reflected or scattered off the symbol. This light is detected and converted into an electrical signal. Electronic circuitry and software decode the electrical signal into a digital representation of the data represented by the symbol that has been scanned. For example, the analog electrical signal generated by the photo detector is converted by a digitizer into a pulse or modulated digitized signal, with the widths corresponding to the physical widths of the bars and spaces. Such a digitized signal is then decoded, based on the specific symbology used by the symbol, into a binary representation of the data encoded in the symbol, and subsequently to the information or alphanumeric characters so represented.

The decoding process of known bar code reading system usually works in the following way. The decoder receives the pulse width modulated digitized signal from the digitizer, and an algorithm, implemented in the software, attempts to decode the signal. If the start and stop characters and information between them in the scan were decoded successfully, the decoding process terminates and an indicator of a successful read (such as a green light and/or an audible beep) is provided to the user. Otherwise, the decoder receives the next scan, performs another decode attempt on that scan, and so on, until a satisfactorily decoded scan is achieved or no more scans are available.

Such a signal is then decoded according to the specific symbology into a binary representation of the data encoded in the symbol, and to the information or alphanumeric characters so represented. The decoded information may be stored or subjected to data processing.

Moving-beam laser scanners are not the only type of optical instrument capable of reading bar code symbols. Another type of bar code reader is one which incorporates detectors based on solid state imaging arrays or charge

-4-

coupled device (CCD) technology. In such prior art readers the detector is typically smaller than the symbol to be read. Accordingly, image reduction is performed by an objective lens in front of the array or CCD. The symbol may be illuminated with light from a light source such as light emitting diodes (LED) in the scanning device, and each array cell is sequentially read out to determine the presence of a bar or a space. A code reading engine employing imager technology is disclosed in U.S. Application Serial No. 09/096,578 filed September 1, 1998 and assigned to applicant herein.

It is known to provide multiple actuators in hand held optical code readers. For example, a system disclosed in U.S. Patent No. 5,117,098, uses a multi-position trigger switch in a hand-held laser scanner. The scanner is aimed at the symbol to be scanned during a first operational state in which an aiming pattern is emitted. Once the user had aligned the scanner properly with respect to the location of the symbol, the trigger switch is actuated again to put the device into a second operational state in which the beam is scanned across the symbol in the normal scanning or reading mode, and the symbol decoded. European Patent No. 0355355 describes a combination bar code reader and EAS tag deactivator, including an embodiment with a multi-position trigger.

U.S. Patent No. 5,600,121, assigned to applicant, discloses, *inter alia* a system for reading indicia such as bar code symbols having a scanner for generating a scanning light beam directed toward a symbol to be read; a first actuator manually displaceable from a first position to a second position for producing a first light beam for aiming or positioning the reader, and a second actuator manually displaceable from a first position to a second position for initiating a scanning beam pattern for reading the symbol. The actuators are independently operative of each other. A detector receives the reflected light from the symbol and produces electrical signals corresponding to data represented by the symbol. A graphical user interface simplifies system control functions.

-5-

There is a need, however, for a more compact and versatile bar code reader which is simply and inexpensively fabricated. Moreover, such a reader would be easy to use and provide user access and feedback for a broad range of functions.

5 Accordingly, it is an object of the present invention to provide a compact and versatile bar code reader which is simply and inexpensively fabricated.

It is another object of the present invention to provide a hand held bar code reader with an ergonomically designed shape and configuration of actuators and indicators.

10 It is a further object of the present invention to provide a bar code reader which provides a broad range of data acquisition, data verification and downloading functions, while being easy to use and providing feedback to the user.

15 These and other objects and features will be apparent from the following summary and descriptions of preferred embodiments.

SUMMARY

20 A portable hand held optical code reader is disclosed which includes a housing, data processing circuitry and a code reading module. The code reading module is located in the housing. The housing is of a generally elongate bar shape equal to or less than four and three-quarters inches in length having generally opposing upper and lower broad faces, shallow side faces and front and rear ends. The housing has a circumference of no greater than five inches
25 and is shaped generally elliptically when viewed from a side. The rear end of the upper and lower faces is rounded when viewed from above.

The housing further includes at least one actuator, preferably two, the actuator(s) being located on the upper face of the housing. A reading window is located on the front end face of the housing. The housing is sized and

-6-

configured to be held in the palm of the user's hand and actuated by one or more fingers of the user.

The hand held code reader may be part of a portable data collection system.

5 The hand held reader may be a battery operated mobile unit for acquiring and storing data. Data may be stored in the reader's memory including, for example, UPC item codes, quantity data, electronic coupon data, transaction summaries, decode counts, etc. A host terminal with superior data access, and computational and display capabilities may be used in conjunction with the code reader to enhance system versatility and performance.

10 A docking station may provide an interface with the host terminal. The docking station may include a cradle adapted to receive and secure the mobile, handheld reader. A detector detects when the reader is placed in the cradle. Data received from the reader may be selectively downloaded when the reader is placed in the cradle. An actuator on the reader may be employed for initiating the transfer of data to a processor in the host terminal if the detector indicates the reader has been placed in the cradle.

15 The data interface may be electrical or optical. In the latter case, in a preferred embodiment, the cradle is equipped with an LED and a photo detector. The LED is positioned to project optical data signals through the scan window of the code reader when it is inserted into the cradle. Optical data signals from the code reader may be emitted by one or more display LEDs of the code reader, which signals are detected by the cradle photo detector.

20 The data interface may be electrical or optical. In the latter case, in a preferred embodiment, the cradle is equipped with an LED and a photo detector. The LED is positioned to project optical data signals through the scan window of the code reader when it is inserted into the cradle. Optical data signals from the code reader may be emitted by one or more display LEDs of the code reader, which signals are detected by the cradle photo detector.

25 In preferred embodiments, the portable code reader includes a light source for generating a beam directed toward a symbol to be read. A detector receives light from the symbol to produce electrical signals corresponding to data represented by the symbol. A first actuator is operatively connected to the reader and manually displaceable from a first position to a second position; and a second, less accessible, actuator is operatively connected to the reader,

-7-

independently operative from the first actuator, and manually displaceable from a first position to a second position.

In a more preferred embodiment, the first and second actuators are generally identified with the functions of scan and delete, respectively. The pressing and holding of the appropriate actuator for a scanning period (for example, 3 seconds) while scanning an item bar code serves to perform the identified function, i.e. increasing the count of the item by one in the case that the first actuator is pressed or decreasing the count of the item by one when the second actuator is pressed. Holding one of the actuators for a longer period of time while scanning an item may perform a different function. For example, holding the second actuator for 3 seconds past the scan time may cause the code reader to perform the clear all function, i.e. reduce the count of the scanned item to zero.

The approximately simultaneously activation of said first actuator and said second actuator followed by holding of both actuators for a predetermined interval may be used to change the mode of operation of the reader. In one embodiment, the code reader has an operating mode and a non-operating mode, and the actuation of both actuators changes the code reader between said operating and said non-operating mode, for example to lock out further operation of the code reader. Alternatively, the reader has a first and a second operating mode, and the actuation of both actuators changes the code reader from the first to the second operation modes or vice versa.

The mobile or hand held unit may include a laser scan module. The module includes a generally circular planar base including a circuit board. A semi-conductor light source may be supported by the base, for generating a laser beam along a first optical path to a symbol to be read. A generally planar, reciprocally oscillatable reflector may be positioned above the base and located in the first optical path, for directing the laser beam impinging on the reflector to the symbol. A spring is coupled to the reflector, and supports the reflector for

-8-

reciprocal oscillating movement. A drive supported by the base reciprocally oscillates the reflector, the drive including a permanent magnet operatively connected to the reflector, and an electromagnetic coil positioned adjacent thereto. When an alternating drive signal is applied to the coil, the coil produces an alternating magnetic field which acts on the permanent magnet to oscillate the magnet and, in turn, flex the spring and reciprocally oscillate the reflector about an axis.

A photo detector mounted on the base generates an electrical signal indicative of the detected light intensity. A one piece optical element includes a beam folding section for folding the laser beam prior to transmission to said reflector and a collection mirror portion arranged to receive retro-reflected light from the reflector and to direct it to said photo detector.

The foregoing has been provided as a convenient summary of preferred embodiments. However, the invention to be protected is defined by the claims herein and the range of equivalents properly accorded thereto.

BRIEF DESCRIPTION OF THE DRAWINGS

Figure 1 is a pictorial view of an optical code reader and cradle in accordance with a preferred embodiment of the present invention;

Figure 2 is a side view of the code reader and cradle of Figure 1;

Figure 3 is a pictorial view of the optical code reader of Figure 1 removed from its cradle and held in the palm of the hand of a user;

Figures 4a and 4b are cross-sectional side views of two cradles employed in preferred embodiments of the present invention;

Figures 5 and 6 are, respectively, a top view and a bottom view of a top housing half of an optical code reader of a preferred embodiment of the present invention;

-9-

Figures 7 and 8 are, respectively, top and bottom views of a circuit board assembly used in a preferred embodiment of the present invention;

Figure 9 is a top view of a bottom housing half of an optical code reader of a preferred embodiment of the present invention, in partial cut away;

5 Figure 10 is a schematic block diagram illustrating various electronic sub-systems usable in data collection systems in accordance with aspects of the present invention;

Figure 11 is a state transition diagram of a preferred embodiment of the present invention;

10 Figure 12 is a timing diagram for the lock toggle function of a preferred embodiment of the present invention; and

Figure 13 is a side cross-sectional view of a laser scan module used in a preferred embodiment of the present invention.

15

DETAILED DESCRIPTION OF PREFERRED EMBODIMENTS

Table of Contents

5	I.	Housing Actuators and Ergonomics of Code Reader Embodiments
	II.	Cradle, and Electrical and Optical Interfaces
10	III.	Internal Construction Including Single Circuit Board and Battery Terminal Structure
	IV.	Optical/Electronic Systems
15	V.	Host Terminal Implementations and Uses for the Code Reader
	VI.	Optomechanical Layout of Cylindrical Module Embodiment

-11-

Many aspects of the present invention are contained in or useable in a preferred embodiment of the present invention whose external construction and appearance are depicted in Figures 1-3.

5 This portable handheld optical code reader 30 is of a generally elongate bar shape equal to or less than four and three quarters inches in length having generally opposing upper and lower broad faces 31 and shallow side faces 33. The circumference of the code reader at its thickest portion 29 is about five inches, such that it fits comfortably in the average human hand as shown in Figure 3. The front end is truncated to form a face to accommodate a scanner
10 exit window 34. The rear end 35 is generally tapered and is adapted to nest in a cradle 32. Overall the reader is shaped generally elliptically when viewed from the angles shown in Figures 1 and 3.

It will be understood that many aspects of the present invention described below may be adapted for use in this as well as other handheld or stationary
15 optical code readers.

***I. Housing, Actuators and Ergonomics
of Code Reader Embodiments***

20 Figures 1 and 2 are, respectively, pictorial and side views of the optical code reader 30 and cradle 32 configured in accordance with a preferred embodiment of the present invention. The code reader 30 is generally elliptical in shape with slightly rounded upper and lower ends as viewed in Figures 1 and 3. Figure 2 is a right side view of the code reader. The left side view is a
25 mirror image of Figure 2.

A scanner exit window 34 is located at one end of the reader (the top end in Figures 1 and 3). The actuators comprise a scan button 36 and a delete button 38. Feedback to the user is provided by a three-color LED display visible through LED window 40. A removable battery cover 42 is located on the
30 opposite side of the reader from the buttons and LED window.

-12-

Figure 3 is a pictorial view of the optical code reader 30 of Figures 1 and 2, shown removed from the cradle 32 and held in the hand of the user. The Figure illustrates, among other things, the approximate size of the code reader. The Figure also shows how the code reader fits in one hand, where it can be easily and accurately aimed. The scan button 36 may be pressed with the thumb to initiate scanning. Access to the delete button 38 is partially obstructed by a raised casing area 44, which reduces the possibility of inadvertent actuation of the delete button 38.

II. Cradle, and Electrical and Optical Interfaces

With continued reference to Figure 3, the code reader 30 also may include a communication connector socket 46 at the rear end of the device into which a plug 48 may be inserted. The plug and socket may be used to electronically transfer collected optical code data to a personal computer or other suitable data handling terminal.

In a more preferred embodiment the plug 48 is a miniature stereo phone plug located in the cradle 32. The structure of such a cradle and plug is shown in greater detail in the cross-sectional view of Figure 4(a). The structure may be easily fabricated from a pre-made miniature phone plug and cable assembly 50. The plug portion 52 may have a molded casing 54 which snaps into and out of corresponding walls 56 of the cradle 32. This construction has the advantage that a stock cable can be used for communication either by itself or in conjunction with the cradle 32. A switch in the socket 46 may be used to detect insertion of the plug and to disable the laser scanner when the plug is inserted in the code reader.

An optional optical interface may also be conveniently provided using a suitable cradle or docking station. The structure of such a cradle 60 is shown in Figure 4(b) in cross-section. A code reader 30 of a preferred embodiment of the

-13-

present invention is shown inserted in the cradle 60. When so inserted the LED display window 40 of the reader is located adjacent to a photo detector 62. A light emitting element or LED 64 is located on a optical path of the code reader 30, to project an optical signal to the code reader 30 through the scanner exit window 34.

In operation an RS 232 output port of the reader 30 may be electrically connected to the LED display and to a photo detector employed in the scanning module of the reader. Data may be input into the reader 30 by means of the LED 64 as indicated by signal line 66. Light produced by the LED 64 is projected along an optical input path which may be collinear with an optical input path of the scanner during normal scanning operations. Detection input data may be digitized and applied to a data receptor line of a microcontroller of the reader. Advantageously, the input data may be transmitted at about a 9600 band rate which approximates the frequency band associated with light signals produced when a bar code is scanned. Thus, the input electronics of the reader may be optimized to one frequency band common to both bar code scanning and optical interface signal input.

Data may be optically outputted from the code reader 30 by employing the display LED. Light produced by a display LED for example a red display LED may pass through LED display window 40 and be detected by the photo detector 62, where it is converted to a electrical signal and passed to a host or terminal as indicated by signal line 68.

It will be understood from the foregoing that the reader 30 may be provided with two modes of connectivity: electrical and optical. The electrical communication mode may be implemented at lower cost and may be more appropriate for home use, especially where the reader host is a home personal computer. The optical cradle requires electrical power for the LED 64. It may be more appropriate in heavy use environments such as a centralized host Kiosk in a store which exchanges data with many code readers and which is always

-14-

ready to accept data from the code readers it services. It will be understood that while the optical interface cradle or dock may be more expensive to fabricate, it is less susceptible to wear and tear caused by, for example, electrical contact degradation.

5 Further alternative types of cradles or docks may employ either of the above described electrical or optical interfaces, but contain further circuitry permitting direct access to and communication with telephone, cable or internet lines.

10 *III. Internal Construction*

The internal construction of the optical code reader 30 of Figures 1 through 3 will now be described. The top housing half 100 of the optical code reader is shown in plan view in Figure 5, wherein like features of the
15 embodiment of the preceding Figures are identified by the same numerals. The underside of the top housing half 100 is shown in plan view in Figure 6. A flexible button pad member 102 is attached to the housing half 100 at 104. The pad assembly 102 includes a scan button portion 106 and a delete button portion 108 integrally connected to each other by the elongated, flexible, serpentine
20 portion 110. Flange portion 112 and 114 of the button portions are normally held against the housing half 100 by internal protruding posts 116 which rest on an underlying circuit board assembly 152 depicted in Figures 7 and 8. Activation pillars 118 and 120 are integrally formed in their respective button portions 106 and 108 respectively.

25 In operation, when the scan button 106 is depressed, it triggers an electrical switch 150 located on an underlying circuit board assembly 152 shown in Figure 7. Likewise, when the delete button 108 is depressed, it triggers an electrical switch 154, also located on the circuit board assembly 152.

-15-

The circuit board assembly 152, will now be described in greater detail in connection with Figures 7 and 8. The circuit board assembly is shown in Figure 7 positioned in a lower housing half 156 and held in position by post 157 and pressure tabs 159, both carried by the lower housing half 156. The scanner exit window is located at 158. A scanner module or engine 160 is located on the underside of the circuit board assembly 152 and directs a laser scanning beam outward through the exit window at 158.

A scanner module useful in the code reader of the present invention is constructed in the shape of a rectangular solid and known as an SE 900 scanner module. Such a scanner module is disclosed in U.S. Patent Application S.N. 09/275,858 filed March 24, 1999 which is hereby incorporated by reference. Alternatively, the scanner module may be a "scanner on a chip" such as disclosed in U.S. Patent Application S.N. 09/209,243 filed December 10, 1998 which is hereby incorporated by reference. As a further alternate the scanner module may be of a cylindrical type as discussed below in connection with Figure 13. Finally, the optical detection may be performed by a code reading engine employing imager technology such as disclosed in U.S. Patent Application S.N. 09/096,578 filed September 1, 1998 and hereby incorporated by reference.

The circuit board assembly 152 includes a single main circuit board 161 on which electrical components are mounted, including switches 150 and 154, display LED 162, micro processor chip 164, memory chip 166 and I/O communications chip 168. Advantageously, the display LED is a conventional bi-color LED (red and green) capable of producing red, green and yellow light (yellow light being produced by combining red and green light). A communication connector socket 170 and the scanner module may be mounted on the underside of the circuit board 161 as shown in Figure 8.

Figure 9 illustrates the lower housing half of the optical code reader, with an upper wall of a battery compartment 180 cut away to reveal the location

-16-

of the batteries 182 and 184, battery compartment side walls and spring contacts. In a preferred embodiment the batteries are AAA type batteries.

5 An outer side wall 186 of the battery compartment forms a side wall which encircles the batteries. Inner end walls 188 and 190 are configured with small apertures 192 slightly larger than the protruding contacts 194 (positive terminals) employed on standard 1.5 volt batteries. In operation the contacts 194 penetrate in the apertures 192 and make electrical contact with conductive spiral helical springs 196 and 198.

10 The opposite ends (negative terminals) 199 of the batteries are formed substantially flat and rest against helical springs 200 and 202 which protrude through larger apertures 204 in the inner side walls 188 and 190.

15 Spiral helical springs 196 and 200 are electrically connected together. Spiral helical springs 198 and 202 end in spring loaded arms 206 and 207, respectively. When the circuit board assembly 152 is positioned in the lower housing half 156, the spring arms maintain themselves in pressural contact with conductive lands 208 on the underside of the circuit board 161 shown in Figure 8. Thereby, the batteries are connected in series to provide an appropriate voltage (typically 3V DC) to the circuit elements of the optical code reader.

20 It is conventional to include at least one diode in the power supply circuit of hand held battery powered scanners and other battery powered devices to prevent damage to the circuitry if a battery is inadvertently installed backwards (i.e., with its positive and negative terminals reversed). The need for such measures is obviated by the structures of Figure 9. It will be readily understood that the contact spring for the positive battery terminal is accessible only if the protruding terminal 194 of the battery is inserted into the small aperture 192. 25 These same contact springs are inaccessible to the wide, flat negative terminal of the battery. Accordingly, if a battery is inserted backwards, the circuit is not completed.

IV. *Optical/Electronic Systems*

Figure 10 is a schematic block diagram of a preferred embodiment of an optical code reading system of the present invention. Portions of the systems of Figure 10 are described in U.S. Patent No. 5,801,371, the contents of which is hereby incorporated by reference herein. Generally speaking, the system elements enclosed by the dotted line 209 may be housed in a hand held optical code reader 210, while the systems outside line 209 may be resident in an external computer or terminal which communicates with the reader through a communications link such as described above.

The hand held code reader 210 includes an optical code reading module 211 which may be an imager or a laser scan module of conventional construction or of the type described in detail below. The bar code being read is indicated at 212.

The module is controlled by a controller 214 which may be implemented in a microprocessor. The controller receives at least three user signals: from the scan key switch 216; from the delete key switch 218 and from the docking switch 220. The keys may be actuated by the fingers of the user; the docking switch may be actuated by insertion of a communication plug 222 into the docking switch.

The optical code reader 210 provides feedback directly to the user in at least two ways: through audible signals produced by one or more audio enunciators 224 and through visual signals produced by one or more light emitting diodes 226. In a preferred embodiment, the code reader provides audio feed back in the form of short or long beeps of two different frequency and warble beeps. Visual feedback may include continuous (solid) or flashing red, amber and/or green light signals from the LED. The audio enunciator(s) and LED(s) are operated response to the controller 214. Preferred techniques for providing the user feed back are described below.

-18-

Signals from the module 211 may be processed in signal processor 228 and decoded by decoder 230. Decoded signals may be provided for storage in the memory 232 which may have, for example, a capacity to store information of up to 500 scanned items (UPC codes). Information concerning coupons
5 (discussed below) may preferably be stored in a separate memory or a distinct section of an existing memory. This segregation reflects the fact that coupon data may be stored for the duration of multiple scanning or shopping sessions until used. Information in the memory or memories may be communicated to an external terminal 234 through communications unit 236, the plug 222, cable
10 238.

A clock 240 may be included in the circuitry of the code reader. The clock may be employed, for example, to periodically awaken the code reader at scheduled times or intervals for data downloading. The clock may also be connected to a display (not shown) so that the code reader can be used as a time
15 piece.

V. Host Terminal Implementations and Uses for the Code Reader

With continuing reference to Figure 10, the optical code reader 210 may
20 communicate with the terminal 234 in the manner described above. The type of terminal and communication used with the code reader will depend on the use environment for the code reader. Several examples will now be provided.

It will be understood that versions of the optical code readers described may be very inexpensively fabricated. So much so that it becomes feasible to
25 sell the unit to store customers for use in tallying their purchases in store and/or for use at home in preparing shopping lists. As an alternate the code reader could be leased to the customer. The rental can be based on time (for example a monthly rental fee). More preferably, the rental may be based on the number of decodes performed by the customer with the unit. The numbers of decodes or

-19-

accumulated rental charges can be counted by software and hardware in the code reader or in a store terminal with which the code reader periodically communicates. In this system, the rental is based on use and can be conveniently tallied and automatically collected when the code reader communicates with a system terminal.

In one preferred embodiment, the system terminal may be a personal computer. Through the appropriate selection of the communication unit 236 and the cabling, the reader may communicate directly with a serial port of the personal computer. The code reader and cradle may be provided as an inexpensive preferral component. Applications software installed on the computer enables the upload of a data from the code reader to the computer. Such software may be provided to the computer, for example, on magnetic media, CDs or over the Internet.

With appropriate applications software the PC can recognize when the code reader is docked in the cradle. The PC can, for example, download information from the docked reader at a predetermined time. Docking may automatically disable the scanning mode of the code reader.

In other preferred embodiments, the system terminal may be a highly capable point of sale terminal. The point of sale terminal may bring together inputs and data from a variety of sources other than the hand held optical code readers of customers and employees. Such sources include a pen tablet, a fingerprint recognition pad, a magnetic strip reader (e.g. for credit card verification), a smart card reader (with or without contacts), a speech recognition system, a global positioning system (GPS), an RF transceiver, removable memory cards or discs, analog I/O, IrDA data or an encryption/decryption system. Outputs of the terminal may include a display, a speaker system and a printer.

In a shopping environment, the system may provide additional functions such as aisle sorting the customers shopping list or providing price ranges for

-20-

items on the list. Such information can be obtained by connecting the code reader to the merchants' data server to obtain product, price and/or location data on the items which the merchant has for sale.

Advantageously, a portion of the internal memory of the code reader can be allocated to a variety of applications other than storing information on scanned items. For example, 128 bytes of memory could be allocated to applications memory. Among the data which could be stored in the applications memory are the customer's name, the customer's telephone number, the identity of the issuing store or owner of the scanner and the telephone number of the store. The customer and the store identity and telephone numbers, provide convenient means by which a host terminal can greet and identify the user of the code reader and indicate and access the associated issuer or store. Alternatively or in addition, each code reader may be provided with a memory of its unique serial number which a host terminal may use to look up, for example, the identity of the customer or the issuing store. Such identification information may be used in a key and lock system which enables only authorized customers to use the scanner at authorized stores or for authorized purchases.

The allocated applications memory may also be employed to store transaction related data. For example, the memory may store the number of decodes for billing as described above, or keep a store-by-store log of the total dollar purchases (for example for tallying up volume or patronage discounts).

Other memory internal to the code reader may be used for storing coupon data. For example, an electronic coupon can be uploaded by scanning the bar code of a printed coupon or by electronically downloading the coupon from a web site or by simply inputting the coupon into the code reader when the code reader is connected to a merchant host terminal. For example, memory for 200 or 300 coupons might be provided including coupon values, expiration dates and validity data.

-21-

An example of the operation of a coupon redemption process is as follows. A customer could load electronic coupons into the reader in one or more of the ways described above. The customer could scan purchased items with the code reader. Data concerning both the purchased item and the electronic coupon could be downloaded by a merchant host terminal, which would pair valid coupons with corresponding purchases. The host terminal would discard expired coupons, delete used coupons, and return unexpired, unused coupons to the memory of the code reader.

In other preferred embodiments, a method is provided for using the bar code reader to facilitate a transaction between a buyer and at least one of a plurality of merchants or sellers of a product or service utilizing a computer network. In accordance with that method, a product or service identification derived from scanning a bar code symbol is input into the bar code reader. A customer identifier is provided in the bar code reader (for example, a unique serial number permanently stored in the bar code reader). The bar code reader is manually associated with a transaction terminal linked to a computer network by, for example, docking the code reader in a host terminal. The potential suppliers on the network capable of providing the product or service are determined. An inquiry is transmitted over the network to the plurality of sellers to determine the price and availability of the product or service. In some environments such as stock transactions, price and availability change rapidly and it will be understood, that sales transactions can be performed in a timely way with the present method. Also, the sellers can use the customer identity to determine whether and under what terms to complete the sale. Responses are received in the host terminal from one or more sellers including a sales offer; an acceptance is transmitted responsive to one of said sale offers; and a payment is provided to the seller by using a payment identifier transmitted by the transaction terminal. In this way the network is accessed by the bar code reader to facilitate sales transactions.

-22-

In other preferred embodiments, a customized scanner is employed which carries an identifier of a particular supplier or distributor of a product or service, *e.g.* a sponsoring merchant. The sponsoring merchant may itself distribute its bar code readers to customers or potential customers. In this case the bar code reader may be used to facilitate transaction between a customer and the particular supplier to whom an inquiry is transmitted over a computer network to determine the current price and availability of a product or service from the supplier. The customer may receive a response from the supplier over the computer network including a current price. The customer may then transmit an acceptance identifier to the supplier over the computer network.

In further, preferred embodiments, the code reader is integrated with a wireless transceiver unit to facilitate a transaction between a buyer and a seller. For example bar code scanners of the present invention may be integrated into a cellular telephone. In such a case, the need to dock the scanner with a host terminal or home P.C. to upload or download data may be obviated. The user of such a system may input an order or bid request and directly transmit the order or bid request to a supplier. It will be understood that a customer or supplier identifier in the unit may be used for the purposes described above, in order, for example to direct customers to a sponsoring merchant, or to identify the customer to validate use, payment or acceptance.

VI. Actuator States, Timing, Indicators and Functionality.

Figure 11 is a state transition diagram, illustrating the coordination of various functions of the optical codes reader/PC system of a preferred embodiment of the present invention. In the diagram various code reader operation such as scan, dock and delete are represented as circles. System states are represented as squares. The PC operation of viewing a list of stored items is shown in a rounded square accessible from the "dock" operation. The diagram, indicates, among other things, the various options or responses to the condition of full memory or low battery.

As noted above, the code reader of a preferred embodiment has two user actuated keys and a number of audio and visual feedback capabilities. These inputs and outputs are coordinated with at least five basic functions: Scan (e.g., item input), deletion of item, clearing memory, communicating with a host terminal and actuating a lock out. The relationship of the user action to function performed and audible/visual feedback are given in the following Table I.

TABLE I
Code Reader Functions - User Action/Feedback

Function Performed	User Action	LED Feedback (Green, Red, Amber)	Beeper Feedback	Other
Scan Item bar code Valid param bar code Invalid param bar code	Press & hold scan key	Flashing green -> solid green Flashing green -> solid green Flashing green -> solid red	Short beep, freq1 2 short beeps, freq1 3 short beeps, freq1	Laser Laser Laser
	Delete (When enabled) Item barcode	Flashing amber-> solid amber	Short beep, freq2	Laser
	Item doesn't exist	Flashing amber-> solid red	Warble beep.	Laser
Param bar code (Delete disabled- Clear All enabled) (Delete & Clear All disabled)	Press & hold delete key	Flashing amber-> solid red	3 short beeps	Laser
	Press & hold delete key	Flashing amber Fall through to Clear All	None	Laser
	Press & hold delete key	None	None	None
Clear All (When enabled) (When disabled)	Press & hold delete key 3 sec past scan time	Flashing amber-> solid amber	Long beep, freq2	Laser on for scan time, then off
	Hold delete key past scan time	None	None	None
Host Communication Successful (Powerdown recv'd) Unsuccessful	Unit docked and awakened by Host or push of scan or delete key	Flashing green-> solid green	Short beep on host connect, then long beep on power down	None
		Flashing green-> solid red		None
Child Lock Toggle (When enabled)	Press & hold both scan and delete keys for 1 sec	None	Hi low, Hi low	None

-25-

Under the "Scan" function, three possibilities and their user feedbacks are noted in Table I: scan of an item bar code, scan of a valid param bar code and scan of an invalid param bar code. Param bar codes are bar codes which change the behavior or basic functionality of the code reader, rather than indicating the identity of a particular item in the manner of a UPC code. As such the param bar code may be used to effect or toggle higher level operations such as for example converting the code reader to a laser pointer.

Under the "Delete" function, three possibilities are noted in Table I: scan of an item bar code previously entered in memory, scan of a bar code not in memory, and scan of a param bar code. When the delete function is enabled, the scanning of an item bar code previously entered in memory, deletes one of the item from memory. Repeated use of this delete function may be used to decrement the quantity field in memory for the item, one unit at a time. Scanning of the bar code of an item whose current count in memory is zero while pressing and holding the delete key, provides the user a feedback signal of the inability to delete. Param bar codes may be scanned to enable or disable the Delete function and Clear All function (described below).

Under the Clear All function, two possibilities are noted in Table I: when Clear All function is enabled or when Clear All function is disabled. When the Clear All function is enabled, pressing and holding the delete key while scanning an item bar code and holding the delete key 3 seconds past the scan time, deletes all of the items memory (reduces the item count to zero) and provides the indicated user feedbacks. In this way the memory can be cleared of all of an item, and, if desired, one or more of the item may then be reentered by using the Scan function for the item bar code. Advantageously, the default setting of the code reader is one in which both the Clear All and Delete functions are enabled.

As shown in Table I a Lock Toggle is provided in the code reader. The system may be employed to shut out unauthorized use to protect data and to

-26-

prevent inadvertent eye exposure to laser light. As indicated in Table I the function is performed by pressing and holding both the scan and delete keys for one second. Because of the location of the two keys and the location of the blocking ridge 44 around the delete key, accidental toggling of the lock is minimized.

5

Figure 12 is a switch timing diagram for the Lock Toggle function. In the example, the state of a first key pressed (the scan or delete key) is indicated by line 250. The state of the other key is indicated by line 252. A delay of T occurs during which the unit powers up and recognized the first key press at 254. An additional interval of up to 200 milliseconds is provided for pressing of the other key to toggle the lock out function. If the second key is pressed within that interval (as it is at 256) and if both keys remain depressed for the remainder of the 1 second interval, the lock is toggled. The requirement that actuation of both keys be detected within the 200 millisecond period tends to prevent lock out toggling except in situations where the user intended to simultaneously press both buttons.

10

15

The code reader is also capable of communicating certain special conditions such as MEMORY LOW (reader memory nearly filled to capacity), MEMORY FULL, BATTERY LOW, LOCK ENABLED AND ON, and UNEXPECTED FAILURE. (The BATTERY DEAD condition is implicitly communicated because the system ceases to respond altogether when the battery is dead). The relationship of user actions, the special conditions, and the audible/visible feedback are given in the following Table II.

20

TABLE II
Code Reader Functions-User Action/Feedback
Special Cases

Special Condition	User Action	LED Feedback (Green, Red, Amber)	Beeper Feedback	Other
Memory Low Scan Item or param bar codes	Press & hold scan key	Flashing red -> Normal operation	Normal operation	Laser
Delete/Clear All	Press & hold delete key	Normal operation	Normal operation	Laser
Memory Full Scan Any bar code	Press & hold scan key	Solid red	Long beeps for 5sec or until scan released	None
Delete/Clear All	Press & hold delete key	Normal operation	Normal operation	Laser
Battery Low Indication (When enabled) Scan Item & param bar codes	Press & hold scan key	Solid red -> normal operation	Normal operation	Laser
Delete Item & param bar codes	Press & hold delete key	Solid red -> normal operation	Normal operation	Laser
Clear All	Press & hold delete key 3sec past scan time	Solid red -> solid amber	Long beep, freq2	Laser on for scan time then off
Lock (Enabled & ON)	scan/delete/dock	Rapidly flashing red	None	None
Unexpected Failure	scan/delete/dock	Flash red, green and amber for 5 sec (Service Call)	None	None
Battery Dead	scan/delete/dock	None	None	None

-28-

It will be understood that the code reader of the above-described embodiments is capable of performing its many functions and provide user feedback without the need of an on board display screen, thus reducing the cost and complexity of the code reader.

5

VI. Opto-mechanical Layout of Cylindrical Module Embodiment

Figure 13 illustrates an embodiment of a laser scan module for use in generally cylindrical housings. The module of Figure 13 employs a mirror mounted on a leaf spring. Alternative embodiments may use spiral tape springs which permit the mirror to pivot about a shaft about which the spiral tape spring is wrapped.

10

15

In Figure 13, the laser scan module 500, includes a generally circular planar base 502. It is adapted to be housed in a generally cylindrical housing such as that indicated at 501. Alternatively the module may be positioned on a code reader main circuit board such as shown in Figure 8. A semiconductor light source 504, such as a laser diode 506 and lens 508 may be located on the base 502. The light source 504 generates a light beam projected along a first optical path indicated by arrows 510.

20

A generally planar, reciprocally oscillated reflector or mirror 512 is positioned above the base and located in the first optical path 510. The reflector directs the laser beam impinging on it toward a code symbol located in the field indicated by arrow 514. A spring coupled to the reflector 512, pivotably supports the reflector for oscillating movement. In the embodiment of Figure

25

13, the spring is a leaf spring 516, fixed to the module at 518. A drive mechanism is also supported on the base 502 for reciprocally oscillating the reflector 512. The drive may include a permanent magnet 520 connected to the reflector and coupled to an electromagnetic coil 522. When an alternating drive signal is applied to the coil 522, an alternating magnetic field is

-29-

produced which acts to oscillate the permanent magnet and, in turn, to flex the spring and reciprocally oscillate the reflector about an axis generally perpendicular to the plane of the Figure.

5 A photo detector 524, such as a semiconductor photo diode is also mounted on the circular base under the reflector. The photo detector generates an electrical signal indicative of light reflected from a target code symbol. A one- piece optical element 526, includes a beam folding section (such as generally planar section 528), and a collection mirror portion (such as curved portion 530). The optical element 526 is designed to receive retro-reflected light
10 from the reflector and direct it to the photo detector 524.

While aspects of the present invention have been described with reference to preferred embodiments and examples, the invention to be protected is defined by the literal language of the following claims and equivalents thereof.

15

-30-

WE CLAIM:

1. An optical code reading system comprising:
 - 5 a handheld optical code reader for storing in an internal memory a count of each of plural different items whose optical codes have been read by said code reader, said code reader having a first actuator and a second actuator; and
 - a docking station adapted to receive the code reader and for downloading data stored by the code reader;
 - 10 wherein the code reader performs the function of scanning an item bar code and storing a count of one of said scanned item in response to each pressing the first actuator while scanning the item and performing the functions of deleting one count of an item or clearing the count of an item in response to reading the symbol associated with the item and pressing the second actuator for
 - 15 a period of time sufficient to initiate the desired one of said deleting and clearing functions.
2. The optical code reading system of claim 1, wherein the docking station includes a cradle and associated electrical connector which contacts an
- 20 associated electrical connector of the optical code reader.
3. The optical code reading system of claim 2, wherein the electrical connector associated with the cradle is a plug which is snap-fit into the cradle.
- 25 4. The optical code reading system of claim 3, wherein the plug is received by a socket of the handheld code reader and wherein the insertion of the plug in the socket engages a switch which disables the code reader from scanning.

-31-

5. The optical code reading system of claim 1, wherein the handheld optical code reader includes at least one LED display for providing a visible feedback to the user.

5 6. The optical code reading system of claim 5, wherein the docking stations includes

a cradle;

a light emitter for directing a light signal to the code reader for providing data to the handheld code reader; and

10 a light detector for detecting a light signal from the LED display for downloading data from the handheld code reader.

7. The optical code reading system of claim 1, wherein one count of the scanned item is deleted in response to pressing the second actuator during the scanning of the item and wherein the count of the scanned item is cleared in response to scanning the item and pressing the second actuator during the scanning of the item and for a predetermined time interval after the scanning of the item.

20 8. The optical code reading system of claim 1, further comprising an LED optical display for producing three different color feedback signals to the user and an audible enunciator for producing plural, distinguishable audible signals.

25 9. The optical code reading system of claim 8, wherein the optical display and audible enunciator produces different combinations of user feedback signals to permit the user to differentiate between scanning of an item, deleting an item attempts to delete an item which does not exist in memory and clearing all of an item from memory.

-32-

10. The optical code reading system of claim 1, wherein the approximately simultaneous activation of said first and said second actuators followed by continued activation of both actuators for a predetermined interval changes a mode of operation of said reader.

5

11. The optical code reading system of claim 10, wherein the reader has an operating mode, and a lock out mode in which scanning cannot be performed.

10

12. The optical code reading system of claim 11, wherein the change in mode of operation of the reader is between said operating and said lock out mode.

15

13. The optical code reading system of claim 10, wherein the reader has a first operating mode as a bar code scanner and a second operating mode as a laser pointer and wherein the change made is between said first and said second operating modes.

20

14. A laser scan module comprising:

(a) a base;

(b) a semiconductor light source supported by the base, for generating a laser beam along a first optical path to a symbol to be read;

(c) a generally planar, reciprocally oscillatable reflector located in said first optical path, for directing the laser beam impinging on the reflector to the symbol;

25

(d) a spring coupled to the reflector, and supportably mounting the reflector for reciprocal oscillating movement;

(e) a drive supported by the base for reciprocally oscillating the reflector, said drive including a permanent magnet operatively connected to

-33-

the reflector, and an electromagnetic coil positioned adjacent thereto, and operative, when an alternating drive signal is applied to the coil, for producing an alternating magnetic field which acts to oscillate the magnet and, in turn, flex the spring and reciprocally oscillate the reflector about an axis;

5 (f) a photo detector mounted on the base for generating an electrical signal indicative of the detected light intensity; and

(g) a one piece optical element including a beam folding section for folding said laser beam prior to transmission to said reflector and a collection mirror portion arranged to receive retro-reflected light from the reflector and to direct it to said photo detector.

10

15 15. The laser scan module of claim 14, wherein data is input to the module from a system docking station by encoding data in light pulses and directing said light pulses at the photo detector during a time when the reflector is not oscillating.

16. The laser scan module of claim 15, wherein the data is input at a baud rate approximating the baud rate of data obtained from a bar code.

20 17. A bar code reader comprising:
a light source for generating a beam directed toward a symbol to be read;
a detector for receiving reflected light from the symbol to produce electrical signals corresponding to data represented by the symbol;
25 a first actuator operatively connected to the reader and manually displaceable from a first position to a second position; and
a second actuator operatively connected to the reader, independently operative from the first actuator, and manually displaceable from a first position to a second position;

-34-

wherein the approximately simultaneously activation of said first actuator and said second actuator followed by continued activation of both actuators for a predetermined interval changes a mode of operation of said reader.

5

18. The bar code reader of claim 17, wherein the reader has an operating mode and a non-operating mode, and wherein the change in mode is between said operating and said non-operating mode.

10

19. The bar code reader of claim 17, wherein the reader has a first and a second operating mode, and wherein the change in mode is between said first and said second operating modes.

15

20. A portable system for collecting data for a processor comprising:
a battery operated mobile unit for acquiring and storing data; and
a docking station including a cradle adapted to receive and secure the mobile unit, said system having a detector for detecting when the mobile unit is placed in the cradle, means for downloading data from the mobile unit when it is placed in the cradle and an actuator on the mobile unit for initiating the transfer of data to the processor only if the detector indicates the mobile unit is placed in the cradle.

20

21. The system of claim 20, wherein the cradle comprises:
a housing adapted for receiving the mobile unit so that an end thereof nests in the housing; and
a plug and cable combination, wherein the plug is snap-fit into an engagement means formed in said housing.

25

-35-

22. The system of claim 21, wherein the plug is molded onto the cable and wherein the plug is releasably engaged by the engagement means of the housing so that the plug and cable combination can be used independently of the cradle for downloading data.

5

23. The system of claim 20, wherein the battery operated mobile unit includes an electrically conductive contact accessible to only one of the positive and negative terminals of a battery used to power the system.

10

24. The system of claim 23, wherein the battery terminal to which the contact is accessible, is a terminal which protrudes from the body of the battery, wherein said terminal protrudes into an aperture of similar size to reach the conductive contact and wherein the aperture will not accommodate an opposite polarity battery terminal of larger size.

15

25. A portable hand held optical code reader comprising:

a housing and a code reading module, the code reading module being provided in the housing, wherein the housing is elongated in shape having a length of less than five inches, having generally opposing upper and lower broad faces, shallow side faces and front and rear ends, and having a circumference of no greater than five inches, wherein the housing is shaped generally elliptically when viewed from a side, wherein the rear end of the upper and lower faces is rounded when viewed from above, and wherein the housing further includes

20

at least one actuator, the actuator being located on the upper face of the housing, and

25

a code reading window located on the front end face of the housing, the housing being sized and configured to be held in the palm of a user and the actuator operated by a finger of the user.

-36-

26. The apparatus of claim 25, further comprising a cradle into which the code reader may be inserted, the cradle including electrical contacts for downloading data from the code reader when it is nested in the cradle.

5 27. The apparatus of claim 25, further comprising a host terminal with which the optical code reader communicates, wherein at least one of the host terminal and the code reader counts the number of decodes performed by the code reader for use in determining a rental charge for using the code reader.

10 28. A sales transaction system utilizing electronic coupons comprising:

a portable handheld optical code reader for scanning different product bar codes corresponding to different types of items, including a first memory for storing counts of each type of item scanned during a session and a
15 second memory for storing data corresponding to electronic coupons; and

a host computer adapted to receive data concerning the type and count of scanned items and data corresponding to electronic coupons from the reader memory and for redeeming the coupons for items scanned.

20 29. A method of processing an electronic coupon corresponding to a product being scanned and purchased comprising:

reading said electronic coupon into a memory of a handheld optical code reader;

25 scanning a product identifying code on said product and storing said code in the memory of the handheld optical code reader;

downloading from the memory of the handheld optical code reader, the electronic coupon and the code of the product being purchased into a host terminal; and

-37-

electronically matching in the host terminal the downloaded electronic coupon with the product code to redeem the coupon.

5 30. The method of claim 29, wherein the electronic coupon is read by scanning a printed bar code corresponding to the coupon.

10 31. The method of claim 29, wherein the electronic coupon is read by uploading digital data from the internet into the memory of the handheld optical code reader.

15 32. The method of claim 29, wherein the electronic coupon is read by uploading digital data from a host terminal into the memory of the handheld optical code reader.

 33. The method of claim 29, wherein expiration data associated with the electronic coupon is also read into the memory of the handheld optical code reader.

20 34. The method of claim 29, wherein plural electronic coupons corresponding to plural purchased products are processed.

 35. The method of claim 34, wherein expiration dates associated with each electronic coupon are read into the memory of the handheld optical code reader.

25 36. The method of claim 35, wherein the codes of all purchased products and all electronic coupons and expiration dates are downloaded to the host terminal; wherein the host terminal matches the purchased products with any unexpired, downloaded electronic coupons to redeem said coupons; and

-38-

wherein the host terminal uploads to the memory of the handheld optical code reader any unused, unexpired electronic coupons.

37. A method for using a bar code reader to facilitate a transaction between a buyer and at least one of a plurality of sellers of a product or service utilizing a computer network comprising:

inputting into the bar code reader a product or service identification derived from scanning a bar code symbol;

providing a customer identifier in the bar code reader;

manually associating the bar code reader with a transaction terminal linked to a computer network;

determining the potential suppliers on the network capable of providing the product or service;

transmitting an inquiry over the network to the plurality of sellers to determine the price and availability of the product or service;

receiving in the terminal responses from one or more sellers including a sales offer;

transmitting an acceptance responsive to one of said sales offers; and

providing a payment to said one seller by using a payment identifier transmitted by the transaction terminal.

38. A method for using a bar code reader to facilitate a transaction between a buyer and a supplier or distributor of a product or service utilizing a computer network comprising:

inputting into the bar code reader a product or service identification derived from scanning a bar code symbol;

providing a customer identifier, a payment identifier and a supplier identifier in the bar code reader;

transmitting an inquiry over the network to the supplier to determine the current price and availability of the product or service;

-39-

receiving in a response from the supplier over the network
including the current price; and
transmitting an acceptance identifier to the supplier over the
network.

5

39. A method for using an integrated bar code reader and wireless
communications transceiver unit to facilitate a transaction between a buyer and a
seller of a product or service in a computer network comprising:

10 inputting into the unit a product or service identification derived
from scanning a bar code symbol;

providing a customer identifier in the unit;

accessing the network by wireless communication to determine if
a seller is capable of providing the product or service;

15 transmitting an inquiry over the network to determine the current
price of the product or service;

receiving in the unit responses from one or more sellers including
a sales offer; and

transmitting an acceptance responsive to one of said sales offers.

FIG. 1

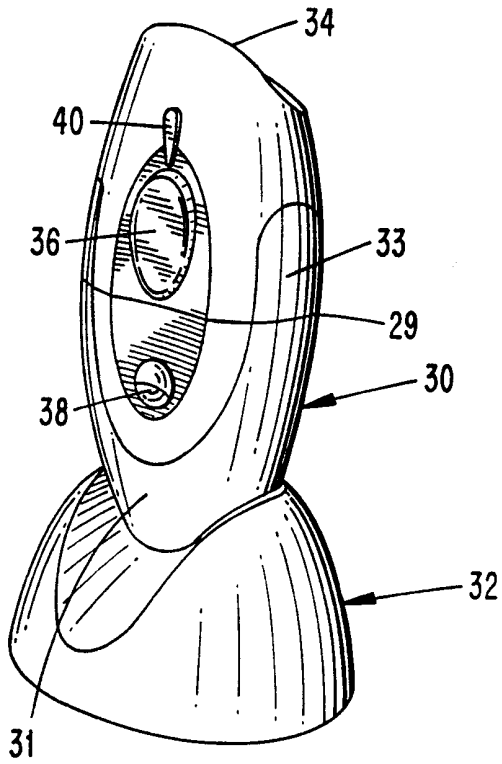

FIG. 2

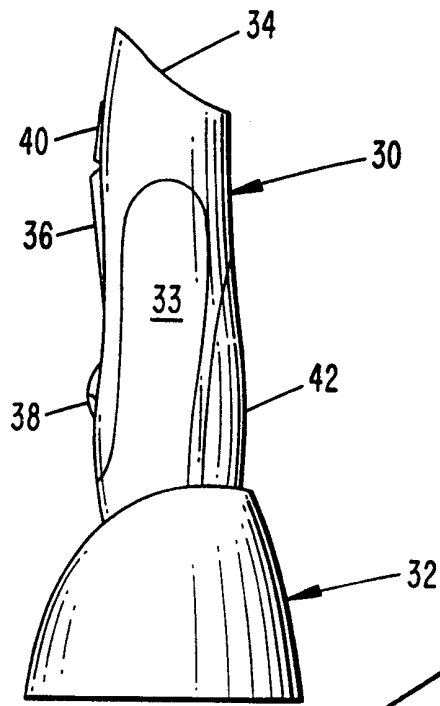

FIG. 3

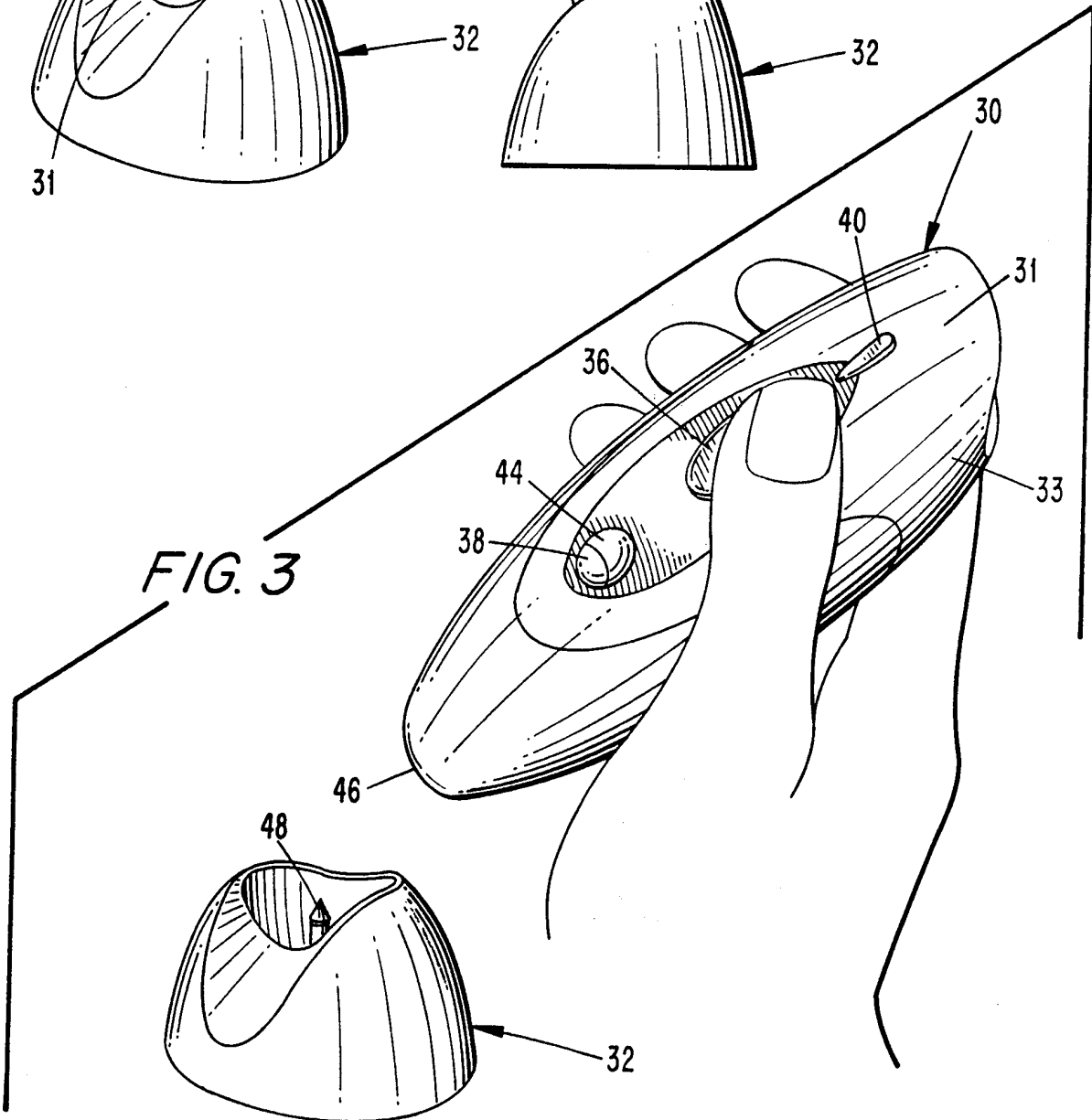

FIG. 9

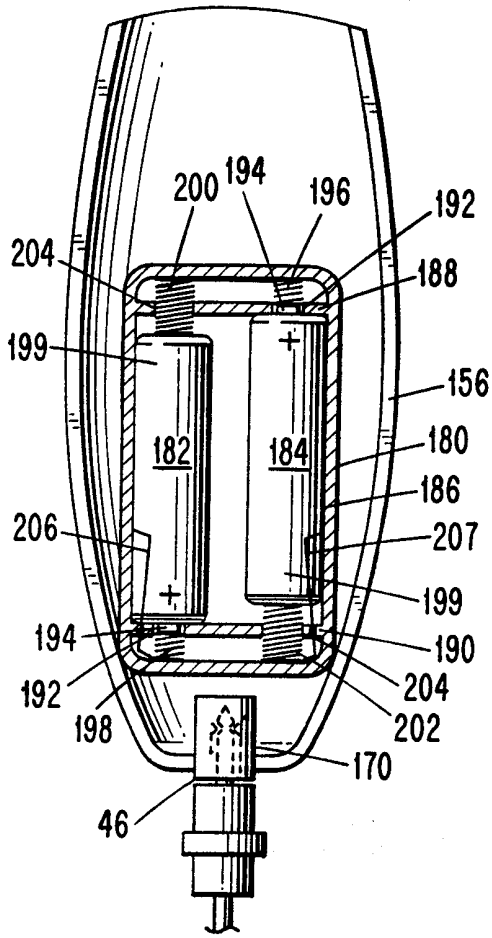

FIG. 4(a)

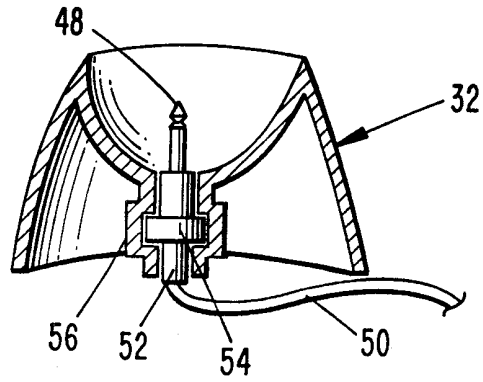

FIG. 4(b)

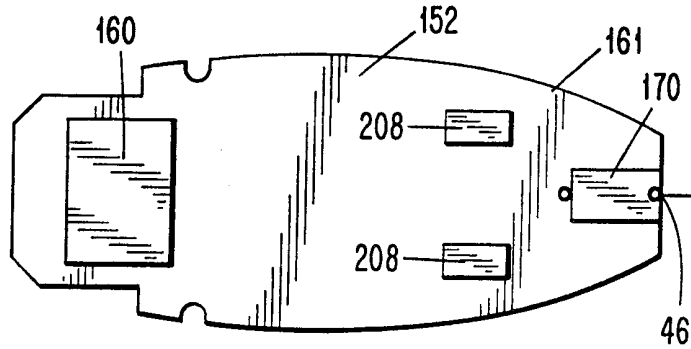
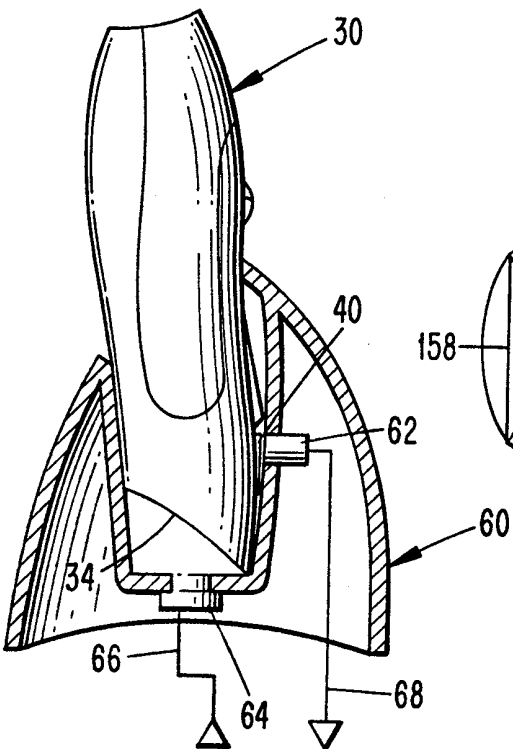

FIG. 8

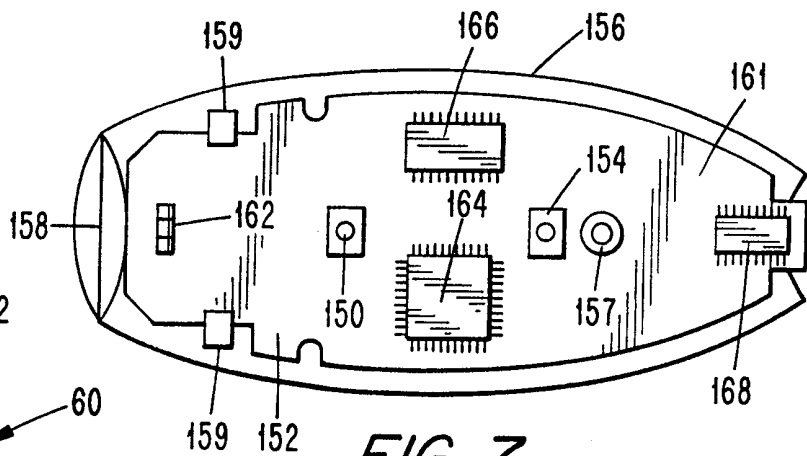

FIG. 7

FIG. 5

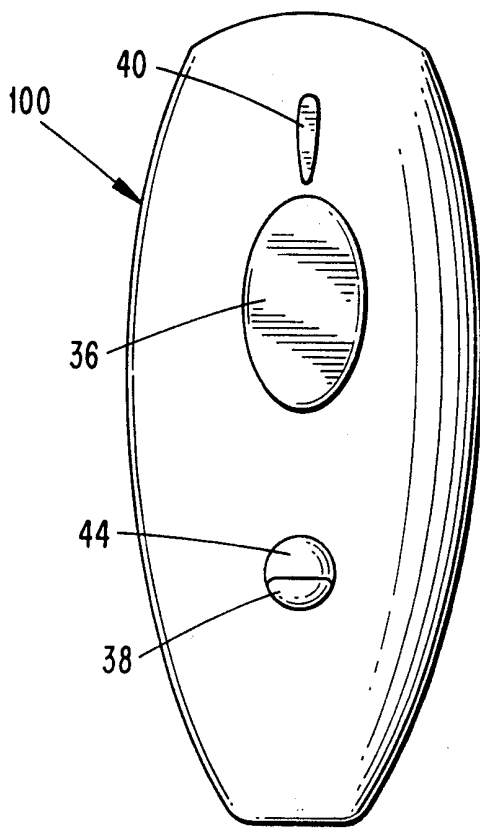
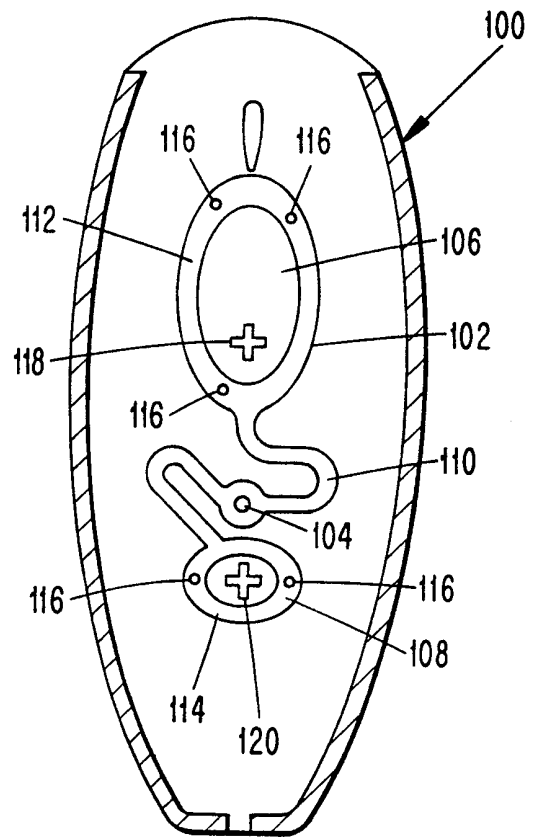

FIG. 6



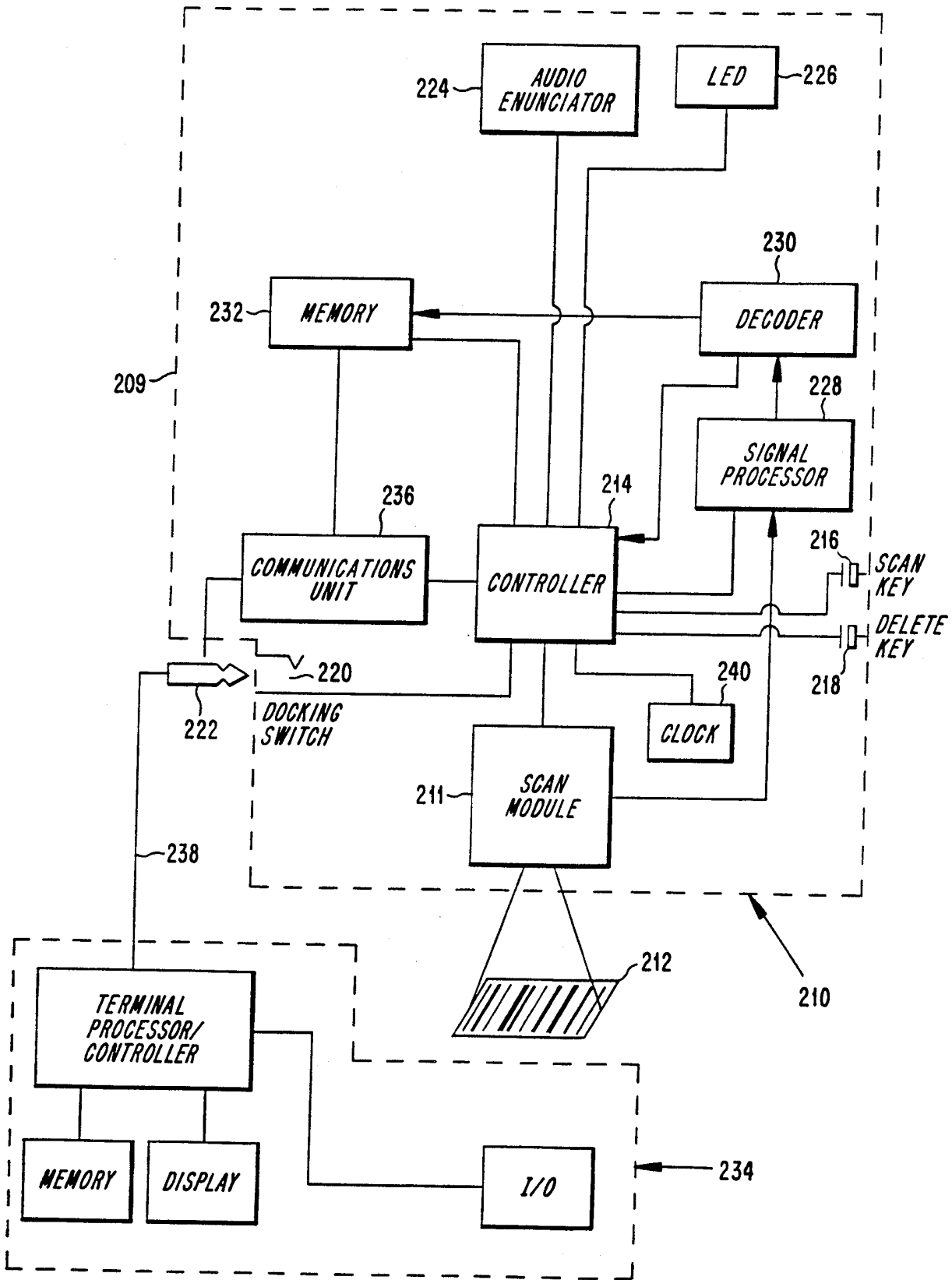
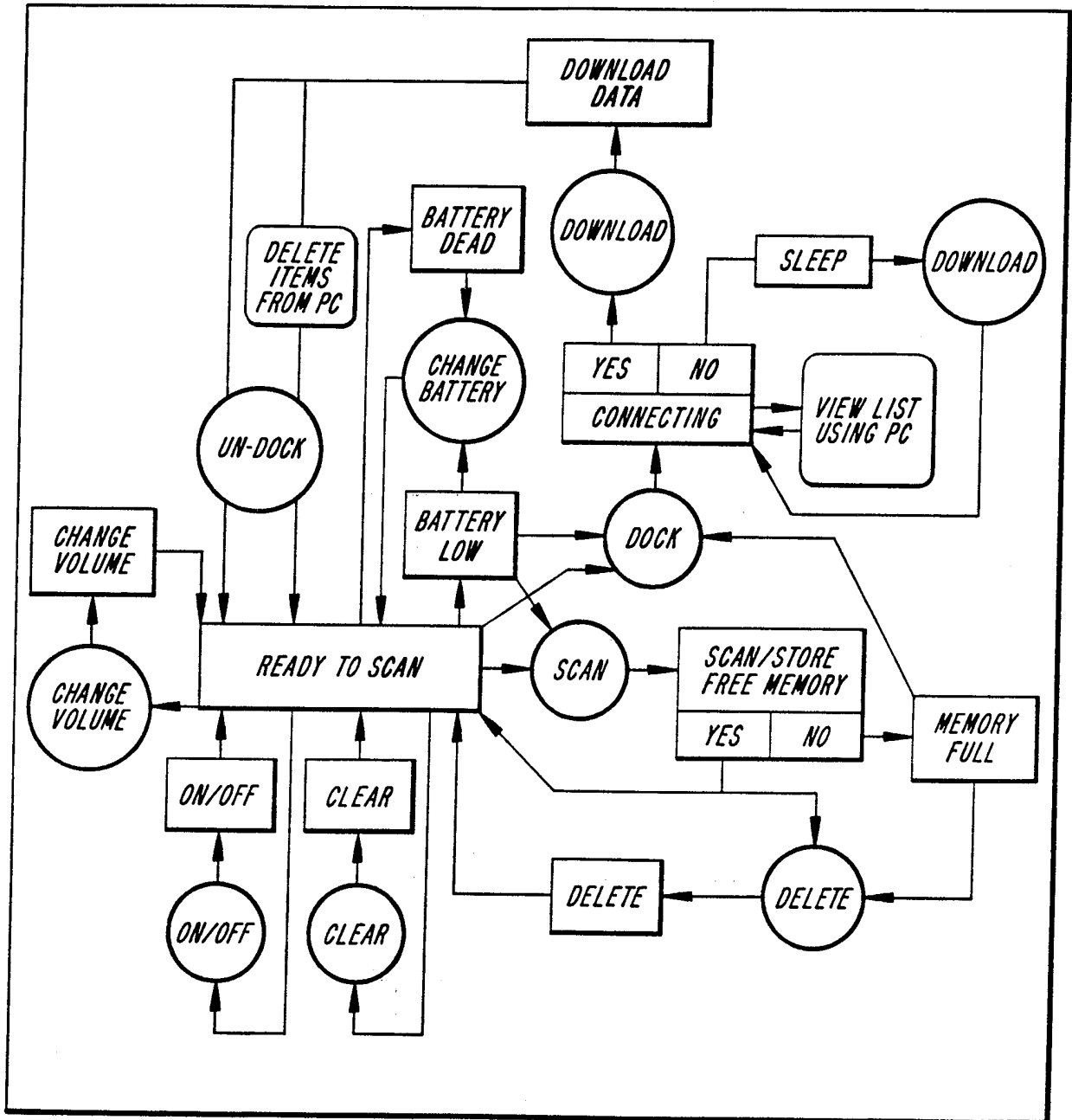

FIG. 10

FIG. 11



STATE

CODE READER OPERATION

PC OPERATION

FIG. 12

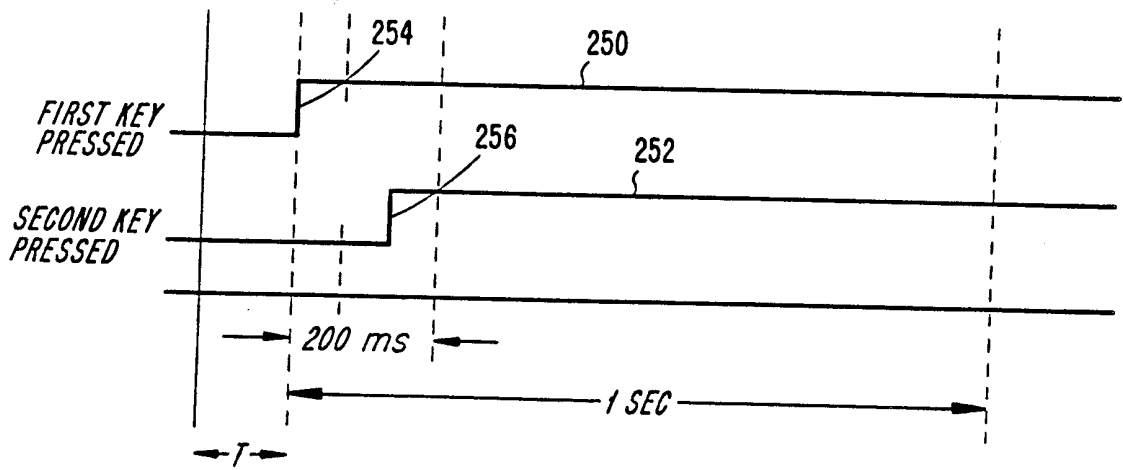
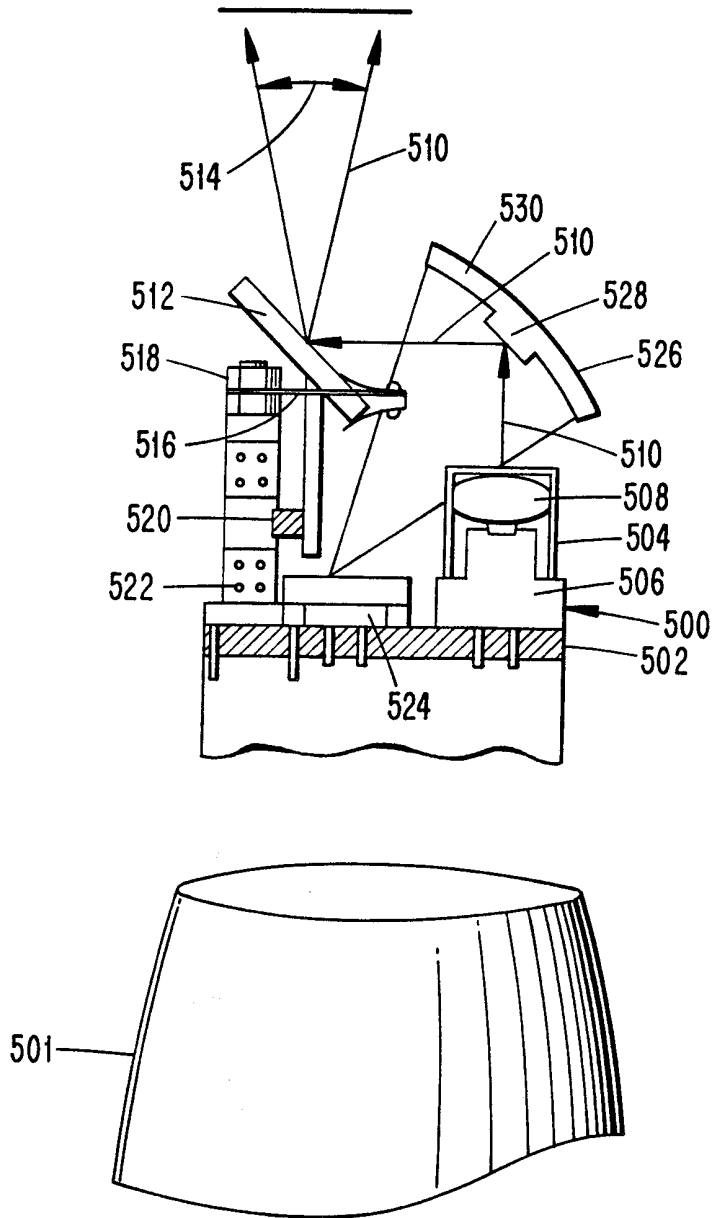

FIG. 13



INTERNATIONAL SEARCH REPORT

International application No.
PCT/US99/31043

A. CLASSIFICATION OF SUBJECT MATTER

IPC(6) : GO6K 7/10
US CL : 356/462.45

According to International Patent Classification (IPC) or to both national classification and IPC

B. FIELDS SEARCHED

Minimum documentation searched (classification system followed by classification symbols)

U.S. : 356/462.45;462.44,462.49,462.36,454,375-385,487; 379/93.17,100.002; 250/239; 186/61; 705/14,16-17,21-23,26

Documentation searched other than minimum documentation to the extent that such documents are included in the fields searched

Electronic data base consulted during the international search (name of data base and, where practicable, search terms used)

C. DOCUMENTS CONSIDERED TO BE RELEVANT

Category*	Citation of document, with indication, where appropriate, of the relevant passages	Relevant to claim No.
P,X ----- Y	US, 5,877,485 A (SWARTZ) 02 March 1999, (02/03/99) (see entire document)	1-3, 7, 20-21 ----- 4-13, 17-19, 22-27
X ----- Y	US 4,850,009 A (ZOOK et al) 18 July 1989,(18/07/89) see entire document	1-9, 20-21 ----- 10-13, 17-19 ,22-27
X	US 5,693,929 A (DVORKIS et al) 02 December 1997, (02/12/97) see entire document	14-16

Further documents are listed in the continuation of Box C. See patent family annex.

* Special categories of cited documents:	"T" later document published after the international filing date or priority date and not in conflict with the application but cited to understand the principle or theory underlying the invention
"A" document defining the general state of the art which is not considered to be of particular relevance	"X" document of particular relevance; the claimed invention cannot be considered novel or cannot be considered to involve an inventive step when the document is taken alone
"E" earlier document published on or after the international filing date	"Y" document of particular relevance; the claimed invention cannot be considered to involve an inventive step when the document is combined with one or more other such documents, such combination being obvious to a person skilled in the art
"L" document which may throw doubts on priority claim(s) or which is cited to establish the publication date of another citation or other special reason (as specified)	"&" document member of the same patent family
"O" document referring to an oral disclosure, use, exhibition or other means	
"P" document published prior to the international filing date but later than the priority date claimed	

Date of the actual completion of the international search
05 MARCH 2000

Date of mailing of the international search report

21 MAR 2000

Name and mailing address of the ISA/US
Commissioner of Patents and Trademarks
Box PCT
Washington, D.C. 20231
Facsimile No. (703) 305-3230

Authorized officer

K. HANTIS

Telephone No. (703) 308-4801

INTERNATIONAL SEARCH REPORT

International application No.
PCT/US99/31043

C (Continuation). DOCUMENTS CONSIDERED TO BE RELEVANT

Category*	Citation of document, with indication, where appropriate, of the relevant passages	Relevant to claim No.
<p>X ----- Y</p>	<p>US 5,665,953 A (MAZZAMUTO et al) 09 September 1997, (09/09/97) see entire document</p>	<p>29-30, 32-36 ----- 28,31, 37-39</p>